



Staff Report

Agenda Item No. D-1

To: City of Imperial Planning Commission
From: Othon Mora, Community Development Director
Date: January 30, 2023
Subject: General Plan Amendment, Zone Change and Revisions to Tentative Map
Morningstar Subdivision
APN 063-010-089

Summary:

Applicant:	Ray Roben
Project Location:	Morningstar Subdivision APN 063-010-089
Pending Action:	<ul style="list-style-type: none">• General Plan Amendment• Zone Change• Revisions to Tentative Map
General Plan:	Existing: Residential Low Medium Density Proposed: Residential High Density Commercial Regional
Current Zoning:	R-1 (Residential Single-Family)
Proposed Zoning:	RA Residential Apartment (5.93 acres) and C-2 Commercial General (14.93 acres)
Environmental:	Negative Declaration
Recommendation:	Recommend the City Council approval of General Plan Amendment, Zone Change and Revisions to Tentative Map

Background/Discussion and Analysis

McMillin Land Development submitted an application in 2005 to annex into the City and subdivide a 181.7-acre site into 489 single family homes, a school site, and 2 park sites. The project site is located on the Southwest corner of Highway 86 and the prolongation of Ralph Road, within the area north of the City. The Applicant requested a General Plan Amendment to change the Land Use designation to Low-Medium Density Residential and Pre-Zoning Designation of R-1, Residential Single Family. All entitlements were approved in 2005.

The current Owner and Developer is now proposing a General Plan Amendment, Zone Change and Revisions to Tentative Map for the City's consideration. The proposed changes and revisions are notable as it relates to design, phasing and internal circulation. The revisions will eliminate the school site of approximately 10.8 acres, which is not needed by the Imperial School Unified District (see attached letter), create 5.93 acres for Residential Apartments and 14.93 acres for Commercial uses. The overall footprint of the project site remains the same.

The Imperial County Fire Department is requesting a capital purchase of a fire engine as a condition of approval. The developer does not agree with this condition and is requesting the Planning Commission consider recommending the project without the imposed condition of approval. It is staff's recommendation that the governing body consider options in the budget process, explore a variety of grants and other funding sources available pertaining capital expenditure purchases.

Location Map

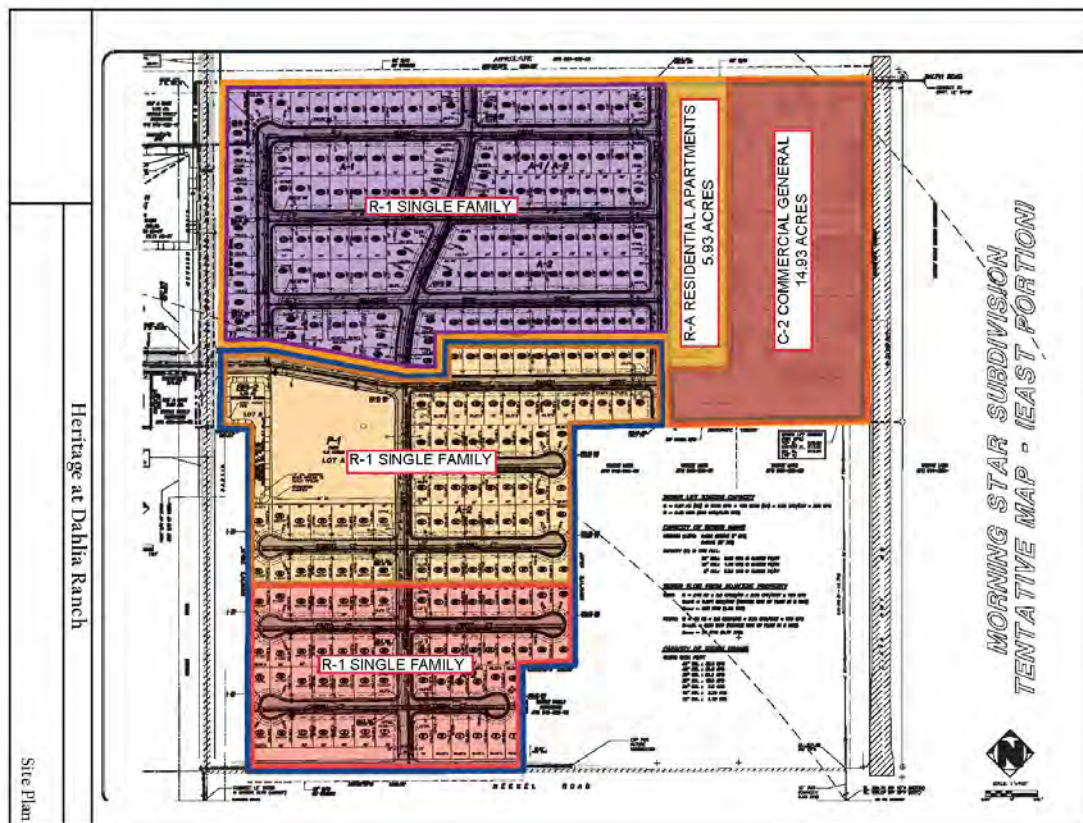

General Plan Land Use Designation

The City of Imperial's General Plan identifies the following policies within its Land Use Element:

Policy 5.4.1 in the General Plan's Land Use Element states "multi-family residential developments of varying types and densities shall be encouraged where compatible with existing land uses and the provision of public services is highest."

Policy 2.1 "Appropriate densities/intensities shall be established for new development projects and increased within the appropriate character areas to accommodate a variety of land use and development types."

The Applicant is requesting a General Plan Amendment to change the Land Use designation of a portion of the Tentative Tract Map area to Commercial Regional that can support residential neighborhoods. This Land Use designation will allow a full range of retail, office, service and institutional businesses within close proximity to and for the convenience of residents. The City's goal is to establish and encourage commercial areas along the City's main arterial roadway, Highway 86, to serve as strong character identification, gateway to the City and draw a regional sales tax base.

Environmental Compliance

The Environmental Evaluation Committee (EEC) reviewed the project and found the project, as proposed, would create potentially significant impacts to transportation and traffic. The applicant provided an updated traffic study and mitigation measures were incorporated. Upon further review, the EEC determined that adoption of a Negative Declaration would be appropriate. The attached Negative Declaration was prepared for the proposed project in conformance with the California Environmental Quality Act (CEQA). The proposed revision from R-1 (Residential Single Family) to RA (Residential Apartments) and C-2 (General Commercial) will not affect a change in the original findings and mitigation measures and will continue to be enforced.

Public Notification

The public hearing scheduled for February 8, 2023 was duly noticed in the Holtville Tribune and Calexico Chronicle, newspapers of general circulation, on January 26, 2023. A Notice of Public Hearing was mailed to all property owners within 300-feet of the property. effect

Recommendation

Staff recommends the Planning Commission conduct a public hearing to receive comments for and against the project. Unless sufficient evidence to the contrary is presented at the public hearing, Staff recommends approval of Resolution No. PC2023-02 approving a General Plan Amendment, Zone Change and Revisions to Tentative Map.

Respectfully Submitted,

Othon Mora, MCM, CBO
Community Development Director

Attachments:

- Resolution PC2023-02 and Conditions of Approval
- Imperial Unified School District Letter
- Concept Site Plan
- Tentative Map 2005
- CEQA Negative Declaration

RESOLUTION NO. PC2023-02

**A RESOLUTION OF THE PLANNING COMMISSION OF THE CITY OF
IMPERIAL, CALIFORNIA, RECOMMENDING THE CITY COUNCIL
APPROVAL OF GENERAL PLAN AMENDMENT, ZONE CHANGE,
SUBDIVISION REVISION TO THE MORNINGSTAR TENTATIVE TRACT
MAP AND CERTIFYING A NEGATIVE DECLARATION
(APN 063-010-089)**

WHEREAS, Ray Roben, has submitted an application for approval of General Plan Amendment, Zone Change, subdivision revisions to the Morningstar Tentative Tract Map and certifying a Negative Declaration; and

WHEREAS, a duly notified public hearing was held by the Planning Commission on February 8, 2023; and

WHEREAS, upon hearing and considering all testimony and arguments, examining and analyzing the information submitted by staff and considering any written and oral comments received, the Planning Commission considered all facts relating to the proposed General Plan Amendment, Zone Change, subdivision revision to the Morningstar Tentative Tract Map and certifying a Negative Declaration.

NOW, THEREFORE, BE IT RESOLVED by the Planning Commission of the City of Imperial as follows:

- A) That the foregoing recitations are true and correct; and
- B) That based on the evidence presented at the public hearing, the Planning Commission hereby finds as follows:
 - 1. The proposed Zone Change and General Plan Amendment are consistent with the goals, objectives and policies of the General Plan;
 - 2. The proposed General Plan Amendment, Zone Change, subdivision revision to the Morningstar Tentative Tract Map are compatible with the surrounding environment;
 - 3. Public facilities and services can be provided to the proposed development without placing undue additional burden on existing residents and businesses; and

- C) That on the findings made above, the Planning Commission recommends **APPROVAL** of the General Plan Amendment and Zone Change, subdivision revision to the Morningstar Tentative Tract Map; and
- D) That based on the evidence presented at the public hearing, the Planning Commission hereby recommends **APPROVAL** of the General Plan Amendment from to Residential Low Medium Density to Residential High Density and Residential Low Medium Density to Commercial Regional, and Zone Change from R-1 (Residential Single Family) to RA (Residential Apartments) 5.93 acres and R-1 (Residential Single Family) to RA (Residential Apartments) 14.93 acres and;
- E) That based on the evidence presented at the public hearing, the Planning Commission hereby recommends **APPROVAL** of a Negative Declaration; and
- F) All recommendations made by the Planning Commission are based on the following findings:
1. The project has been reviewed in accordance with the requirements set forth by the City of Imperial for implementation of the California Environmental Quality Act.
 2. The project is following and in compliance with the California Environmental Quality Act, Section 2100 through 21176 of the Public Resources Code.
 3. The initial environmental assessment shows that there is no substantial evidence that the General Plan Amendment and Zone Change, subdivision revision to the Morningstar Tentative Tract Map and Negative Declaration may **NOT** have a significant impact on the environment.
 4. There are no sensitive resources located within the area of the project or adjacent to the area of the project so as to be significantly impacted by the project.
 5. The proposed Zone Change and General Plan Amendment are consistent with the intent of the Imperial General Plan to maintain land use designation consistency within the incorporated area of the City and its sphere of influence.
 6. The proposed Zone Change and General Plan Amendment are consistent with the policies and the land uses of the existing City of Imperial General Plan.

7. The proposed General Plan Amendment and Zone Change are consistent with the objective of the City of Imperial's General Plan Guidelines and Zoning Ordinance.

PASSED, ADOPTED AND APPROVED by the Planning Commission of the City of Imperial, this 8th day of February, 2023.

Planning Commission Chairman

ATTEST:

City Clerk

EXHIBIT A

CONDITIONS OF APPROVAL FOR GENERAL PLAN AMENDMENT, ZONE CHANGE, SUBDIVISION REVISIONS TO THE MORNINGSTAR TENTATIVE TRACT MAP AND NEGATIVE DECLARATION (APN 063-010-089)

1. The Developer/Applicant shall comply with all local, State and Federal laws, regulations, rules, ordinances, and standards as they pertain to this project, whether specified herein or not. Where conflicts occur, the most stringent shall apply.
2. Water line loop at Ralph Road and Rodeo Drive must be installed and provide points of connection before any certificate of occupancy can be issued.
3. Traffic signals must be provided and installed by the developer at the intersection of Ralph Road and Highway 86.
4. Developer is to underground the Dahlia 8 Drain Canal from South property line to Ralph Road.
5. Ralph Road is to be paved/improved at least 24' wide by the Developer prior to the issuance of the Certificate of Occupancy.
6. The Developer/Applicant shall pay all impact and capacity fees.
7. All maps, plans, studies, cost estimates, designs and calculations required for this project shall be subject to the review and approval of the City Engineer, Department of Public Works and Department of Community Development prior to submittal for approval.
8. This Zone Change and General Plan Amendment is to approve the change of zone from R-1(Single Family Residential) to R-A (Residential Apartment) and C-2 (General Commercial).
9. Prior to construction and issuance of approved building permits, there must be approval of a water supply capable of providing fire flow demands as determined by the Imperial County Fire Department.
10. Curb and gutter improvements are to be provided on south side of Ralph Road.

11. The Imperial County Fire Department is requesting a capital purchase of a fire engine.
12. The Developer/Applicant shall construct trash enclosures, per City standards, shall be provided for dwelling units in the RA Zone. Trash collection standards as deemed by the State of California and City of Imperial for organic waste must be provided as well.
13. The Developer/Applicant shall construct a six-foot (6) solid masonry wall along the south and west boundaries of the project site. The material and color of all walls shall be decorative and subject to the review and approval by the Planning Commission.
14. The Developer/Applicant shall submit a Landscaping Plan to the City of Imperial for review and approval prior to final project approval. Landscaping shall be provided on front, rear and side yards. Where noise abatement walls are required, a five (5) foot landscaped screen shall also be provided.
15. A Grading and Drainage Plan/Study shall be submitted to the City Engineer for review and approval. The Grading and Drainage Plan/Study shall address property grading and erosion control which shall include the prevention of sedimentation or damage to off-site properties. A Storm Water Pollution Prevention Plan (SWPPP) shall be submitted to the City of Imperial for review and approval. Best Management Practices shall be utilized to minimize or prevent storm water pollution.
16. Construction sites shall control dust (PM-10) generation through daily watering in accordance with a dust control plan submitted to and approved by the Air Pollution Control District as required by Imperial APCD Rule 800.
17. All construction activity shall stop during high winds exceeding 20 MPH to prevent excessive dust blowing.
18. The Developer/Applicant shall provide a soils report prior to issuance of a building permit indicating, among other things, suitability of the site for the proposed development, specifications for earthwork, design guidelines for concrete slabs and foundations.
19. The conditional approval of the Zone Change, General Plan Amendment and Negative Declaration shall not constitute the waiver of any requirement of the City's Ordinances or regulations, except where a condition set forth herein specifically provides for a waiver.
20. The Developer/Applicant shall agree to defend, indemnify and hold harmless the City of Imperial and its agents, including consultants, officers and employees from any claim,

action or proceeding against the City or its agents, including consultants, officers and employees to attack, set aside, void, or annul the approval of this Zone Change and General Plan Amendment. This indemnification obligation shall include, but not be limited to, damages, costs, expenses, attorney's fees, or expert witness costs that may be asserted by any person or entity, including the Property Owner/Applicant arising out of or in connection with the approval of the Zone Change and General Plan Amendment including any claim for private attorney general fees claimed by, or awarded to any party from the City.

21. All conditions of approval for this Zone Change and General Plan Amendment shall be reprinted and included as a plan sheet(s) with the building permit plan check sets submitted for review and approval. These conditions of approval shall be on, at all times, all grading, landscaping, and construction plans kept on the project site. It is the responsibility of the Developer/Applicant to ensure that the project Contractor is aware of, and abides by, all conditions of approval set forth in this document. Prior approval from the Planning Department must be received before any changes are constituted in site design, grading, building design, building colors or materials, landscape material, etc.
22. The provisions of these Conditions of Approval are bound to the permit and land/project and shall bind the current and future owner(s) successor(s) in interest, assignee(s) and/or transferor(s) of said project.
23. If the Community Development Department finds and determines that the Permittee or successor-in-interest has not complied or cannot comply with the terms and conditions of the Zone Change and General Plan Amendment, or the Planning/Building Department determines that the permitted activities constitute a nuisance, the City shall provide Permittee with notice and opportunity to comply with the enforcement or abatement order. If after receipt of the order (1) Permittee fails to comply, and/or (2) Permittee cannot comply with the conditions set forth in the then the matter shall be referred to the Planning Commission for modification to conditions of approval, suspension, or termination, or to the appropriate enforcement authority.
24. As between the City and the Permittee, any violation of the Conditions of Approval may be a "nuisance per se". The City may enforce the terms and conditions of this permit in accordance with its Codified Ordinances and/or State law. The provisions of this paragraph shall not apply to any claim of nuisance per se brought by a third party.
25. Permittee shall not be permitted to maintain a "nuisance", which is anything which: (1) is injurious to health, or is indecent or offensive to the senses, or an obstruction to the free use of property, so as to interfere with the comfortable enjoyment of life or property,

and/or (2) affects at the same time an entire community or neighborhood, or any considerable number of persons, although the extent of the annoyance or damage inflicted upon individuals may be unequal, and/or (3) occurs during or as a result of the project.

26. Traffic Impact Study:

- “Prior to the issuance of a building permit and/or the commencement of any grading activities in Caltrans’ Right-of-Way, the owner/permittee shall have an approved Intersection Control Evaluation (ICE) Report in place and demonstrate to the City Engineer that Caltrans Traffic Engineering and Analysis Branch comments have been satisfied on the ICE Report.”
- Within the ICE report, please ensure the following will be included for all alternatives:
 - Evaluate the safety and operational analysis, warrants, and benefit cost ratio for all alternatives.
 - Provide traffic warrants for the signal alternative.
 - Provide a comparison table between these alternatives.
 - Approximately cost of Utility relocations.
 - The comparison between each alternative should be equivalent and in equal unit.
 - Identify a preferred alternative under conclusion or summary of findings.
 - Provide the Synchro files and other files used to analyze traffic for each alternative.
 - Each alternative should also include the future 2042 year to the scenarios.

Traffic Engineering and Analysis:

- Bring curb ramps at the intersection of Ralph Road, Larsen Road, Keystone Road/SR-86 to the current standards. Refer to Design Information Bulletin (BID) 82-06 for more information.

Hydrology and Drainage Studies:

- Please provide hydraulics studies, drainage and grading plans to Caltrans for review.
- Provide a pre and post-development hydraulics and hydrology study. Show drainage configurations and patterns.
- Provide drainage plans and details. Include detention basin details of inlets/outlet.
- Provide a contour grading plan with legible callouts and minimal building data. Show drainage patterns.
- On all plans, show Caltrans' Right of Way (R/W).
- Early coordination with Caltrans is recommended.

- Caltrans generally does not allow development projects to impact hydraulics within the State's R/W. Any modification to the existing Caltrans drainage and/or increase in runoff to State facilities will not be allowed.

27. The Developer shall work with California Department of Transportation to address the issues that were set forth in the letter dated March 3rd, 2022, made a part hereof.

IMPERIAL UNIFIED SCHOOL DISTRICT

Bryan Thomason, Superintendent

Imperial High School
(760) 355-3220

Imperial Avenue Holbrook School
(760) 355-3207

Frank Wright Middle School
(760) 355-3240

ADMINISTRATION OFFICE
219 North "E" Street
Imperial, California 92251-1176
(760) 355-3200
FAX (760) 355-4511
web site: <http://imperialusd.org>

T.L. Waggoner Elementary School
(760) 355-3266

Ben Hulse Elementary School
(760) 355-3210

August 20, 2018

To Whom It May Concern:

RE: Morning Star Subdivision

The 10.8 acre projected school site located in the Morning Star Subdivision will not be needed by the Imperial Unified School District.

Thank you,



Bryan Thomason
Superintendent

BOARD OF TRUSTEES

David Ross

Victor Lopez

Abdul Mohamed

Linda Sanchez

Jill Tucker

CONCEPT SITE PLAN

SCALE: 1"=50'-0"

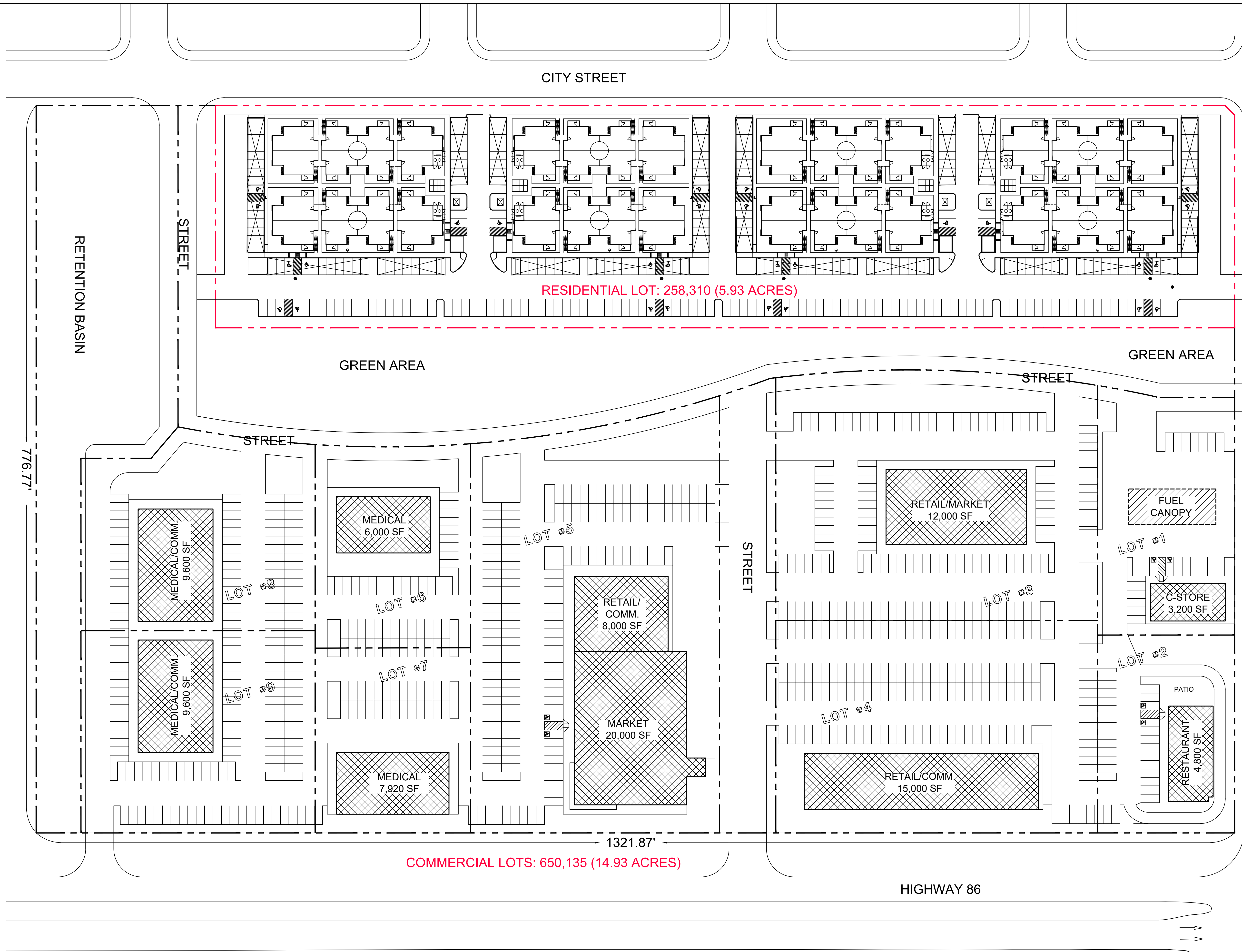

PROPERTY BOUNDARY NOTE:
 THE PROPERTY OR BOUNDARY LINES SHOWN ON THIS PLAN ARE AN APPROXIMATE AND ASSUMED LOCATION. THIS PLAN SHALL NOT BE USED AS A LEGAL DOCUMENT FOR LOCATING, ESTABLISHING OR DEPICTING PROPERTY LINES. IF PROPERTY LINES NEED TO BE ESTABLISHED OR IDENTIFIED, A REGISTERED LAND SURVEYOR WILL PREPARE THE NECESSARY SURVEY

PROJECT:	HERITAGE IMPERIAL, CA
SCALE:	AS SHOWN
DATE:	01/22/2021
DRAWN BY:	
JOB No.:	2020-004
SHEET CONTENTS:	CONCEPT SITE PLAN
DRAWING No.:	1 / 1

MORNING STAR SUBDIVISION

PROJECT LOCATION

NOTE: PROJECT IS NOT WITHIN A 65 CHL. NOISE SPHERE OF INFLUENCE

SPHERE OF INFLUENCE
HYDROLOGICAL SURFACE
84' MSL 150' ABOVE
AIRPORT EL. 56

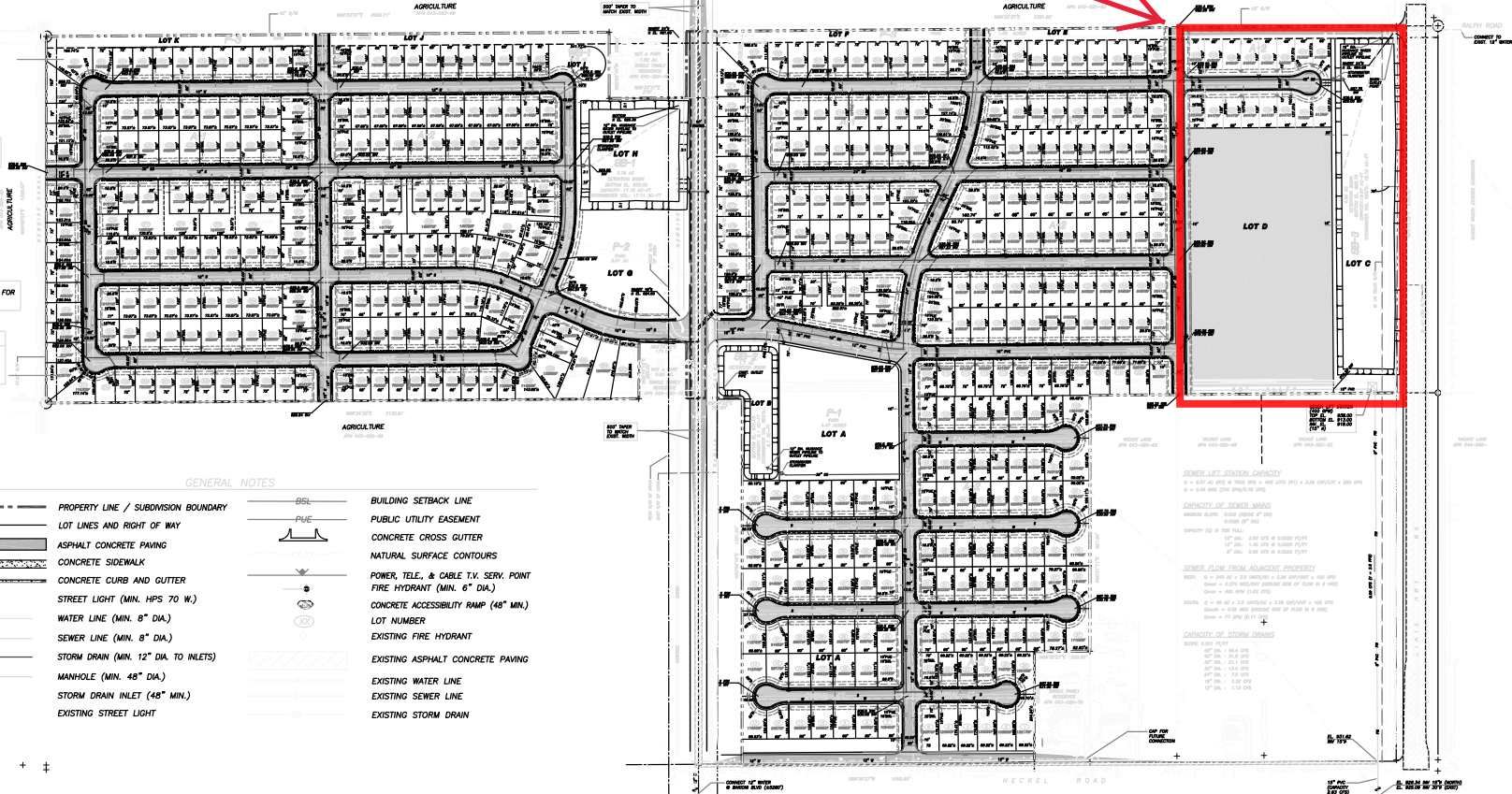

NO AIRPORT COMPATIBILITY RESTRICTIONS

SPHERE OF INFLUENCE FOR COMPATIBILITY ZONE C

AIRPORT COMPATIBILITY "C" ZONE

GENERAL NOTES

- PROPERTY LINE / SUBDIVISION BOUNDARY
- LOT LINES AND RIGHT OF WAY
- ASPHALT CONCRETE PAVING
- CONCRETE SIDEWALK
- CONCRETE CURB AND GUTTER
- ★ STREET LIGHT (MIN. HPS 70 W.)
- W WATER LINE (MIN. 8" DIA.)
- S SEWER LINE (MIN. 8" DIA.)
- SD STORM DRAIN (MIN. 12" DIA. TO INLETS)
- MANHOLE (MIN. 48" DIA.)
- STORM DRAIN INLET (48" MIN.)
- EXISTING STREET LIGHT
- BSL BUILDING SETBACK LINE
- PUE PUBLIC UTILITY EASEMENT
- CONCRETE CROSS GUTTER
- NATURAL SURFACE CONTOURS
- POWER, TELE., & CABLE T.V. SERV. POINT
- FIRE HYDRANT (MIN. 6" DIA.)
- CONCRETE ACCESSIBILITY RAMP (48" MIN.)
- LOT NUMBER
- EXISTING FIRE HYDRANT
- EXISTING ASPHALT CONCRETE PAVING
- EXISTING WATER LINE
- EXISTING SEWER LINE
- EXISTING STORM DRAIN

GENERAL NOTES

- TOTAL AREA OF SUBDIVISION: ±181.7 ACRES
- SOILS REPORT: GEOTECHNICS, INC., REPORT NO. _____
- TITLE REPORT: FIRST AMERICAN TITLE CO. (ORDER NO. 1280368 KMC) DATED 04/16/04
- ZONING: EXISTING A-2 (GENERAL AGRICULTURE) REQUESTED: SINGLE-FAMILY (R1), MULTI-FAMILY (R3)
- DESCRIPTION OF LOTS:
SINGLE-FAMILY, R1 489 EACH
DETENTION BASINS (10.44 ACRES) 3 EACH
SCHOOL (IMPERIAL UNIFIED) - 7.83 AC. 1 EACH
PARK 3 EACH
- PROPOSED ENGINEERING DESIGN STANDARDS:
FIRE DEMAND 1,000 GPM
SINGLE-FAMILY (R1) WATER DEMAND (AVERAGE/PEAKS) 250/750 GPCPD
SINGLE-FAMILY (R1) SEWAGE DISCHARGE (AVERAGE/PEAK) 1100/250 GPCPD
MULTI-FAMILY (R3) WATER (AVERAGE/PEAK) 18,750 GAL/AC/DAY
MULTI-FAMILY (R3) SEWAGE DISCHARGE (AVERAGE/PEAK) 7,500 GAL/AC/DAY
STORM WATER (28 YEAR) (TOTAL, 3 INCHES) 1.0 INCH PER HOUR
CURB W/ GUTTER SLOPE 0.0020 MIN.
SANITARY SEWER SLOPE (8" DIA.-0.0025 MIN.) (12" DIA.-0.0020 MIN.) 0.0025 MIN.
STORM DRAIN SLOPE (12" MIN. DIA.) 0.010 MIN.
FIRE HYDRANT PLACEMENT WITHIN 150 FT. OF EA. LOT
STREET LIGHT SPACING (APPROXIMATE) 300 FT.
MANHOLE SPACING (APPROXIMATE) 400 FT.

- PROPOSED LOT DEVELOPMENT STANDARDS:
LOT SIZES SHALL BE NOT LESS THAN SIXTY (60) FEET WIDE AND ONE HUNDRED TWENTY (120) FEET DEEP WITH A SIXTY-FIVE (65) FEET MINIMUM WIDTH FOR CORNER LOTS. LOTS FRONTING ON CURVED SECTIONS OF STREETS, KNUCKLES, OR CUL-DE-SACS SHALL ALSO BE NOT LESS THAN (50) FEET IN WIDTH MEASURED AT THE STREET RIGHT-OF-WAY.
AVERAGE LOT SIZE 7,800 SF (A-2)/8,640 (A-1) (7,200 SQ. FT. MINIMUM AVERAGE REQUIRED)
SIDE YARDS SETBACK 5 FEET
SIDE YARD AT CORNER SETBACK 10 FEET
REAR YARD SETBACK 10 FEET SINGLE-STORY, 25' FEET TWO STORY
FRONT YARD SETBACK 20 FEET
TREES 2 EACH 15-GALLON SIZE PER LOT
- CITY TO REIMBURSE COST OF IMPROVEMENTS OVER 12" WATER PIPELINE AND APPURTENANCES.
- MULTIPLE MAPS TO BE FILED PER SECTION 66456.1 OF MAP ACT.
- WATER TREATMENT AND DISTRIBUTION BY CITY OF IMPERIAL
- PARK REQUIREMENTS : 489 UNITS x 3.5 PERSONS/1000 x 3 Ac = 5.13 Ac (10.99 AC PROVIDED)

AREA	PERCENT	ACRES	SUALL	DATE
AL-1	NEW CONCRETE	26.41	75.14	2003
AL-2	NEW ASPHALT	59.13	166.08	2003
AL-3	ASPHALT			
AL-4	CONCRETE	11.34		
AL-5	PAVEMENT	16.69		
AL-6	CONCRETE	11.97		
AL-7	ASPHALT	6.73		
TOTAL		181.70		



SCALE: 1"=200'

PROPERTY DESCRIPTION
PARCELS 2 AND 3, PM 8-61 AND PARCEL 2, PM 4-58 IN A POP. TRACT 135, T.15S. - R13/14 E., S2M, COUNTY OF IMPERIAL, STATE OF CALIFORNIA, CONSISTING OF 180 ACRES, MORE OR LESS. NOTE: LOT LINE ADJUSTMENT REQUIRED AT PARCEL 1, PM 8-61 AND PARCEL 1, PM 4-58 (TO CENTERLINE OF LA BRUCHERIE ROAD)

LAND OWNER:
SOUTHERN CALIFORNIA LAND CO., LLC c/o MCMILLIN HOMES
770 MAIN STREET
EL CENTRO, CA 92243
(760) 336-2900

DEVELOPER:
I.V. RESIDENTIAL BUILDERS
1770 MAIN STREET
EL CENTRO, CA 92243
(760) 336-2900

ENGINEER OF WORK:
JBL ASSOCIATES, INC.
242 N. 87TH STREET
EL CENTRO, CA 92243
(760) 352-2105
JEFFREY O. LYON, PE



DATE: 5/28/05
REVISION: MOVED SCHOOL AND R-3 LOTS
REV. No.: 1

JBL ASSOCIATES
DESIGNS & ENGINEERING ANALYSIS
EL CENTRO, CALIFORNIA
242 NORTH 87TH STREET
TEL. (760) 352-2105

MORNING STAR SUBDIVISION
LOCATION: IMPERIAL, CALIFORNIA
SHEET TITLE: TOWNHIP MAP
CLIENT: IMPERIAL VALLEY RESIDENTIAL BUILDERS

SHEET No. A1
BY: SERGIO
DATE: 11/16/04
JOB #: J03129



City of Imperial
**Initial Study/
Environmental Checklist**

1. **Project Title:** Morningstar Subdivision Zone Change R-1 to C-2
2. **Lead Agency:** City of Imperial
420 South Imperial Avenue
Imperial, CA 92251
Contact: Othon Mora
(760) 355-1152
3. **Project Sponsor:** Ray Roben
115 N Imperial Ave., Suite D
4. **Project Location:** APN: 063-010-089
5. **Project Description:** Change of zoning designation from R-1 (Residential Single Family) to C-2 (Commercial General) for a proposed commercial development.
6. **General Plan Designation:** **Existing:** Residential Low Medium Density
Proposed: Commercial Regional
7. **Zoning:** **Existing:** R-1(Single Family Residential)
Proposed: C-2 (Commercial General)
8. **Surrounding Land Uses and Setting:** **North:** Residential Uses
South: Residential Uses
East: Residential Uses
West: Residential Uses

Other Agencies whose approval is required: (e.g., permits, financing approval, or participation agreement)

- a) None

ENVIRONMENTAL FACTORS POTENTIALLY AFFECTED:

The environmental factors checked below would be potentially affected by this project, involving at least one impact that is a “Potentially Significant Impact” as indicated by the checklist on the following pages.

	Aesthetics		Agriculture & Forestry Resources		Air Quality
	Biological Resources		Cultural Resources		Energy
	Geology/Soils		Greenhouse Gas Emissions		Hazards & Hazardous Materials
	Hydrology/Water Quality		Land Use Planning		Mineral Resources
	Noise		Population/Housing		Public Services
	Recreation		Transportation		Tribal Cultural Resources
	Utilities/Service System		Wildfire		Mandatory Findings of Significance

ENVIRONMENTAL ASSESSMENT COMMITTEE DETERMINATION:

On the basis of the attached Initial Study, the City of Imperial Environmental Review Committee finds that:

Categorically Exempt under section of the California Environmental Quality Act:	
The proposed project could not have a significant effect on the environment, and a NEGATIVE DECLARATION will be prepared.	X
The proposed project could have a significant effect on the environment; there will not be a significant effect in this case because the mitigation measures described on an attached sheet have been added to the project. A MITIGATED NEGATIVE DECLARATION will be prepared.	
The proposed project MAY have a significant effect(s) on the environment and an ENVIRONMENTAL IMPACT REPORT is required	
The proposed project MAY have a significant effect(s) on the environment, but at least one effect (1) has been adequately analyzed in an earlier document pursuant to applicable legal standards, and (2) has been addressed by mitigation measures based on the earlier analysis as described on attached sheets, if the effect is a “Potentially Significant Impact” or “Potentially Significant Unless Mitigated.” A FOCUSED ENVIRONMENTAL IMPACT REPORT is required, but it must analyze only the effects that remain to be addressed.	
Although the proposed project could have a significant effect on the environment, there WILL NOT be a significant effect in this case because all potentially significant effects (1) have been analyzed in an earlier EIR pursuant to applicable standards and (2) have been avoided or mitigated pursuant to that earlier EIR, including revisions or mitigation measures that are imposed upon the proposed project. No further action is required.	X

 Othon Mora, CBO, MCM
 Community Development Director

 Date

EVALUATION OF ENVIRONMENTAL IMPACTS:

- 1) A brief explanation is required for all answers except “No Impact” answers that are adequately supported by the information sources a lead agency cites in the parentheses following each question. A “No Impact”

answer is adequately supported if the referenced information sources show that the impact simply does not apply to projects like the one involved (e. g. the project falls outside a fault rupture zone). A “No Impact” answer should be explained where it is based on project-specific factors as well as general standards (e. g. the project will not expose sensitive receptors to pollutants, based on a project-specific screening analysis).

- 2) All answers must take account of the whole action involved, including off-site as well as on-site, cumulative as well as project-level, indirect as well as direct, and construction as well as operational impacts.
- 3) Once the lead agency has determined that a particular physical impact may occur then the checklist answers must indicate whether the impact is potentially significant, less than significant with mitigation, or less than significant. “Potentially Significant Impact” is appropriate if there is substantial evidence that an effect is significant. If there are one or more “Potentially Significant Impact” entries when the determination is made, an EIR is required.
- 4) “Negative Declaration: Less Than Significant With Mitigation Incorporated” applies where the incorporation of mitigation measures has reduced an effect from “Potentially Significant Impact” to a “Less than Significant Impact.” The lead agency must describe the mitigation measures, and briefly explain how they reduce the effect to a less than significant level (mitigation measures from Section 17, “Earlier Analysis,” may be cross-referenced).
- 5) Earlier analysis may be used where, pursuant to the tiering, program EIR, or other CEQA process, an effect has been adequately analyzed in an earlier EIR or negative declaration. Section 15063(c)(3)(D). In this case, a brief discussion should identify the follow:
 - a. Earlier Analysis Used. Identify and state where they are available for review.
 - b. Impacts Adequately Addressed. Identify which effects from the above checklist were within the scope of and adequately analyzed in an earlier document pursuant to applicable legal standards, and state whether such effects were addressed by mitigation measures based on the earlier analysis.
 - c. Mitigation Measures. For effects that are “Less than Significant with Mitigation Measures Incorporated,” describe the mitigation measures, which were incorporated or refined from the earlier document and the extent to which they address site-specific conditions for the project.

Authority: Public Resources Code Sections 21083 and 21087. Reference: Public Resources Code Sections 21080(c), 21080.1, 21080.3, 21082.1, 21083, 21083.3, 21093, 21094, 21151; *Sundstrom v. County of Mendocino*, 202 Cal. App. 3d 296 (1988); *Leonoff v. Monterey Board of Supervisors*, 222 Cal. App. 3d 1337 (1990).

- 6) Lead agencies are encouraged to incorporate into the checklist references to information sources for potential impacts (e.g. general plans, zoning ordinances). Reference to a previously prepared or outside document should, where appropriate, include a reference to the page or pages where the statement is substantiated.
- 7) Supporting Information Sources: A source list should be attached, and other sources used or individuals contacted should be cited in the discussion.

I. AESTHETICS – Would the project:				
	Potentially Significant Issues	Potentially Significant Unless Mitigation Incorporated	Less Than Significant Impact	No Impact
a) Have a substantially adverse affect on a scenic vista or scenic highway?				X
b) Substantially damage scenic resources, including, but not limited to, trees, rock outcroppings, and historic buildings within a state scenic highway?				X
c) Substantially degrade the existing visual character or quality of the site and its surroundings?				X
d) Create a new source of substantial light or glare, which would adversely affect day or nighttime views in the area?				X

Background

The project will not have an impact on scenic vistas. The project will actual be an infill project on parcels that are currently vacant and located within an urbanized developed residential areas.

Impact Discussion

- a) **No Impact.** The proposed project would not have an effect on scenic vista. It is to be located on a currently vacant lot.
- b) **No Impact.** The proposed zone change would not damage scenic resources. The lot is vacant and not considered to have any historic value.
- c) **No Impact.** The proposed project location resides amongst various vacant lots and would enhance the quality and character of the surrounding residential uses/zones via “infill”.
- d) **No Impact.** The proposed future use would be for commercial uses. The light or glare generated will not have an adverse effect on the day or nighttime views. If and when the project is applied for, the increase in density will create new sources of light and glare resulting from the addition of street lights and lighting from the additional commercial stores/uses. The City of Imperial Standards and Specifications requires the installation of low profile exterior lighting, directed away from adjacent properties, and as such, the impact of off-site glare and adverse light intrusion will be less than significant.

II. AGRICULTURE AND FORESTRY RESOURCES – Would the project:				
	Potentially Significant Issues	Potentially Significant Unless Mitigation Incorporated	Less Than Significant Impact	No Impact
a) Convert Prime Farmland, Unique Farmland, or Farmland of State-wide Importance, as shown on maps prepared pursuant to the Farmland Mapping and Monitoring Program of the California Resources Agency, to non-agricultural use?				X
b) Conflict with existing zoning for agricultural use, or a Williamson Act contract?				X
c) Conflict with existing zoning for, or cause rezoning of, forest land (as defined in Public Resources Code section 4526). Or timberland zoned Timberland Production (as defined by Government Code Section 51104(g))?				X
d) Result in the loss of forest land or conversion of forest land to non-forest land?				X
e) Involve other changes in the existing environment which, due to their location of nature, could result in conversion of Farmland, to nonagricultural use or conversion of forest land to non-forest use?				X

Background

The proposed project is to be developed on vacant parcels that are currently zoned for Public Facility uses within an already urbanized area. The project will not have any impact on agricultural uses.

Impact Discussion

- a) **No Impact.** The parcels are currently vacant and zoned R-1 (Single Family Residential). According to the Imperial County Important Farmland 2016 Map, the project site is listed as other lands, thus the proposed project will not convert any type of farmland to non-agricultural use; therefore, no impact is expected.
- b) **No Impact.** The proposed project site is in the midst of existing residences (enclave) and the rezoning of this parcel would not appear to conflict with the existing zoning. There is no Williamson Act land contract on the project site, so the project would not conflict with the Williamson Act land contract. Therefore, no impacts are anticipated.
- c) **No Impact.** The project will have no impact on forest land. Currently a vacant lot zoned R-1 (Residential Single-Family) uses. As mentioned above, the subject property is not zoned for forest land and the General Plan Land Use Map designates this site as "R-1" and the proposed zone change will not conflict with existing zoning or cause rezoning of forest land, timberland or timberland zoned Timberland Production. Therefore, no impact is expected.
- d) **No Impact.** The proposed zone change and project will not result in the loss of forest land. The parcel is currently zoned P-F (Public Facilities). As explained under item c) above, the proposed zone change and will not result in the loss of forest land or conversion of forest land to non-forest use. Therefore, no impact is expected.
- e) **No Impact.** The proposed zone change will not result or influence the conversion of farmlands, forests or agricultural uses to other uses.

III. AIR QUALITY – Would the project:				
	Potentially Significant Issues	Potentially Significant Unless Mitigation Incorporated	Less Than Significant Impact	No Impact
a) Conflict with or obstruct implementation of the applicable air quality plan?				X
b) Violate any air quality standard or contribute substantially to an existing or projected air quality violation?				X
c) Result in a cumulatively considerable net increase of any criteria pollutant for which the project region is non-attainment under an applicable federal or state ambient air quality standard (including releasing emissions that exceed quantitative thresholds for ozone precursors)?				X
d) Expose sensitive receptors to substantial pollutant concentrations?				X
e) Create objectionable odors affecting a substantial number of people?				X

Background

The zone change will not have a negative impact on the air quality. The proposed site is located within the Salton Sea Air Basin and is under the jurisdiction of the Imperial County Air Pollution Control District (ICAPCD). The Imperial Valley has been designated as a “non-attainment” area with respect to State Standards for particulate matter (PM10) and ozone (smog). The ICAPCD recommends that construction projects in the Imperial Valley follow the standard and discretionary mitigation measures outlined in Section VII of the ICAPCD CEQA Air Quality Handbook in order to minimize PM10 and emissions generation on-site. The ICAPCD also suggests that projects incorporate street tree planting and other landscaping along interior streets and project boundaries as these green spaces act as filters for dust and other pollutants.

The proposed zone change will not generate dust but when there is an official commercial building project it is likely to generate dust and other forms of pollutants during Project construction and long-term project emissions will result from traffic generated by the residential development, in the future. Adjacent residences are considered sensitive receptors and may be negatively affected from these short and long-term emissions. The APCD considers a project to be mitigated to a level of insignificance if the project incorporates all feasible mitigation measures listed in Section VII of the handbook and/or exhausts all CEQA options for mitigation subject to CEQA Guidelines §15370.

Impact Discussion

- a) **No Impact.** The proposed zone change will have no impact on any applicable air quality plan. The proposed zone change and any future development shall conform to the requirement of the Imperial County Air Pollution Control District (ICAPCD). Therefore, less than significant impacts are anticipated.
- b) **No Impact.** As explained in Item a) above, the proposed project is a zone change will not result in a cumulative net increase of any criteria pollutant for which the project is non-attainment. The project will not violate any air quality standards or contribute substantially to an existing or projected air quality violation. Therefore, no impacts are anticipated.
- c) **No Impact.** The proposed zone change will not result in any increase of any criteria pollutant for which the region is in non-attainment. The project proposes a zone change with no proposed change to the use and

does not anticipate exposing receptors to substantial pollutants concentrations. Therefore, no impacts are anticipated.

- d) **No Impact.** The proposed zone change will not have an impact nor contribute to pollution. The project proposes a zone change and no proposed change to the current use (vacant lot) and does not anticipate in creating more objectionable odors that already exists with the adherence of ICAPCD requirements.
- e) **No Impact.** The proposed zone change should not create objectionable odors that could potentially effect a substantial number of people. Therefore, no impacts are anticipated.

IV. BIOLOGICAL RESOURCES – Would the project:				
	Potentially Significant Issues	Potentially Significant Unless Mitigation Incorporated	Less Than Significant Impact	No Impact
a)	Have a substantial adverse effect, either directly or through habitat modifications, on any species identified as a candidate, sensitive, or special status species in local or regional plans, policies, or by the California Department of Fish and Game or U.S. Fish and Wildlife Service?			X
b)	Have a substantial adverse effect on any riparian habitat or other sensitive natural community identified in local or regional plans, policies, regulations, or by the California Department of Fish and Game or U.S. Fish and Wildlife Service?			X
c)	Have a substantial adverse effect on federally protected wetlands as defined by Section 404 of the Clean Water Act (including, but not limited to, marsh, vernal pool, coastal, etc.) through direct removal, filling, hydrological interruption, or other means?			X
d)	Interfere substantially with the movement of any resident or migratory fish or wildlife species or with established native resident or migratory wildlife corridors, or impede the use of native wildlife nursery sites?			X
e)	Conflict with any local policies or ordinances protecting biological resources, such as a tree preservation policy or ordinance?			X
f)	Conflict with the provisions of an adopted Habitat Conservation Plan, Natural Community Conservation Plan, or other approved local, regional, or state habitat conservation plan?			X

Background

The proposed zone change is for a vacant parcel within an urbanized area that is zoned for Single-Family Residential (R-1).

Impact Discussion

- a) **No Impact.** The proposed project site is located within disturbed land and does not appear to have a substantially adverse effect, either directly or through habitat modification, or any species identified as a candidate, sensitive or special status species in local or regional plan, policies, or regulation, or by the Departments of Fish and Wildlife. Therefore, no impacts are anticipated.

- b) **No Impact.** The proposed zone change is for a vacant parcel that is currently zoned R-1(Single Family Residential). As mentioned under item a) above, the project site is located within disturbed land and does not appear to have a substantial effect on any riparian habitat or other sensitive natural community identified in local or regional plan, policies, and regulations or by the Departments of Fish and Wildlife. Therefore, no impacts are anticipated.
- c) **No Impact.** There are not any wetlands within the vicinity of the proposed zone change location. As explained in Item a) above, the project proposes a zone change on land that is currently zoned for public facility uses and has already been disturbed, will not cause a substantial adverse effect on federal protected wetlands as defined by Section 404 of the Clean Water Act (including but not limited to, marsh, vernal pool, coastal, etc.) through direct removal, filling, hydrological interruption, or other means. Therefore, no impacts are anticipated.
- d) **No Impact.** The zone change is proposed for a vacant parcel that is zoned R-1 and surrounded by residential zoning and uses. As mentioned under Item a) above, the proposed zone change will not interfere substantially with the movement of any residential or migratory fish or wildlife species or with established resident or migratory wildlife, corridors or impede the use of native wildlife nursery sites. Therefore, no impacts are anticipated.
- e) **No Impact.** The proposed zone change will not conflict with any local policies or ordinances protecting biological resources, such as a tree preservation policy or ordinance. Therefore, no impact is expected.
- f) **No Impact.** The zone change will not conflict with the provisions of an adopted Habitat Conservation Plan, Natural Community Conservation Plan, or other approved local, regional, or state habitat conservation plan.

V. CULTURAL RESOURCES – Would the project:				
	Potentially Significant Issues	Potentially Significant Unless Mitigation Incorporated	Less Than Significant Impact	No Impact
a) Cause a substantial adverse change in the significance of a historical resource as defined in Section 15064.5?				X
b) Cause a substantial adverse change in the significance of an archaeological resource pursuant to Section 15064.5?				X
c) Directly or indirectly destroy a unique paleontological resource or site or unique geologic feature?				X
d) Disturb any human remains, including those interred outside of formal cemeteries?				X

Background

The proposed zone change is to be located on a vacant parcel that is not tied to nor has been identified by the State of California to have any cultural value or history. The project will not have an adverse change in the significance of a historical resource as defined in §15064.5.

Impact Discussion

- a) **No Impact.** The project will not cause adverse change with historical resources. It is to be located on a vacant lot. The project will not have an adverse change in the significance of a historical resource as defined in §15064.5.
- b) **No Impact.** The project will not cause adverse change with archaeological resources. It is to be located on a vacant lot on disturbed land and is not expected to directly or indirectly destroy a unique paleontological resource or unique geologic feature. Therefore, any impacts should be less than significant.
- c) **No Impact.** The project will not directly or indirectly destroy a unique paleontological resource or site or unique geologic feature on disturbed land and is not expected to directly or indirectly destroy a unique paleontological resource or unique geologic feature.
- d) **No Impact.** The project will not have an impact on human remains. As mentioned under Item a) above, the project site is located on disturbed land and is not expected to result in the disturbance of any human remains, including those interred outside of dedicated cemeteries. Therefore, any impact would be less than significant.

VI. ENERGY – Would the project:				
	Potentially Significant Issues	Potentially Significant Unless Mitigation Incorporated	Less Than Significant Impact	No Impact
a) Result in potentially significant environmental impact due to wasteful, inefficient, or unnecessary consumption of energy resources, during project construction or operation?				X
b) Conflict with or obstruct a state or local plan for renewable energy or energy efficiency?				X

Background

The zone change will not create unnecessary consumption of energy. The proposed zoning is to be Commercial General. The existing zone is Single Family Residential (R-1). The energy consumption between the existing and proposed use does not increase nor change much.

Impact Discussion

- a) **No Impact.** Will not result in potentially significant environmental impact due to wasteful, inefficient, or unnecessary consumption of energy resources, during project construction or operation.
- b) **No Impact.** Will not conflict with or obstruct a state or local plan for renewable energy or energy efficiency.

VII. GEOLOGY AND SOILS – Would the project:				
	Potentially Significant Issues	Potentially Significant Unless Mitigation Incorporated	Less Than Significant Impact	No Impact
a) Expose people or structures to potential substantial adverse effects, including risk of loss, injury, or death involving:				
1) Rupture of a known earthquake fault, as delineated on the most recent Alquist-Priolo Earthquake Fault Zoning Map issued by the State Geologist for the area or based on other substantial evidence of a known fault? Refer to Division of Mines and Geology Special Publication 42.				X
2) Strong seismic ground shaking?				X
3) Seismic-related ground failure, including liquefaction?				X
4) Landslides?				X
b) Result in substantial soil erosion or the loss of topsoil?				X
c) Be located on a geologic unit or soil that is unstable or that would become unstable as a result of the project, and potentially result in on- or off-site landslides, lateral spreading, subsidence, liquefaction or collapse?				X
d) Be located on expansive soil, as defined of the latest in Table 18-1-B Uniform Building Code, creating substantial risk to life or property?				X
e) Have soils incapable of adequately supporting the use of septic tanks or alternative waste water disposal systems where sewers are not available for the disposal of waste water?				X
f) Directly or indirectly destroy a unique paleontological resource or site or unique geologic feature?				X

Background

The parcel is currently vacant and zoned for public facilities. At the time of “Building Permitting” any soil issues that can arise, foreseen and unforeseen will be addressed.

Impact Discussion

- a) **No Impact.** Project and zone change is to allow for commercial building uses, the proposed project will not cause or expose people or structures to potential substantial adverse effects, including risk of loss, injury, or death involving rupture of a known earthquake fault, as delineated on the most recent Alquist-Priolo Earthquake Fault Zoning Map issued by the State Geologist for the area or based on other substantial evidence of a known fault. Therefore, less than significant impacts are expected.
 - 1. According to the State of California's Alquist-Priolo Earthquake Fault Zone Maps, Revised January 1, 1980, Specials Studies Map, the proposed project site is not located in a "Special Studies Zone". The site could be affected by the occurrence of seismic activity, but no more that the surrounding properties. The project would need to comply with the California Building Code (CBC). Compliance with the CBC would reduce the risk to a level less than significant.

2. Per the City of Imperial Conservation and Open Space Element, the project site is in a high seismic area. However, any potential impact would not be greater to the project site than elsewhere in the region. The main concern of ground shaking is the corresponding structure damage and the related hazards to life and safety. To ensure the structural integrity of all buildings and structures, the project must conform to the Seismic Requirements as outlined in the California Building Code. Compliance with the CBC does not eliminate the risk associated with ground shaking; however, it would reduce the risk to a level less than significant.
3. The project site is on relatively flat terrain and is not within a "Landslide Susceptibility Area" as identified by the GGS Seismic Hazard Zonation's Program (SHZP) Data Access Page, and the Imperial County General Plan, Seismic and Public Safety Element, Figure 2 (Landslide Activities). Additionally, the project site is not adjacent to any shore line and, therefore is not subject to a seiche or tsunami.
 - b) **No Impact.** Project and zone change is to allow for a multi-family residential use. The project site is not located within an erosion susceptible area according to the Imperial County, Seismic and Public Safety Element, Figure 3; therefore, no impact is expected.
 - c) **No Impact.** Mitigation measures are incorporated at the time of "Building Permit Processing" for structure integrity and compliance with CA Building Code standards. The project site is not located on a geological unit or soil that is unstable or would become unstable due to the expansion to this existing facility; therefore, no impact is expected
 - d) **No Impact.** Mitigation measures are incorporated at the time of "Building Permit Processing" for structure integrity and compliance with CA Building Code standards. The project site is not characterized by any expansive soils that would be considered environmentally significant. Potential impact deriving from expansive soils are considered negligible. Therefore, no impacts are anticipated.
 - e) **No Impact.** Mitigation measures are incorporated at the time of "Building Permit Processing" for structure integrity and compliance with CA Building Code standards.

VIII. GREENHOUSE GAS EMISSIONS – Would the project:					
		Potentially Significant Issues	Potentially Significant Unless Mitigation Incorporated	Less Than Significant Impact	No Impact
a)	Generate greenhouse gas emissions, either directly or indirectly, that may have a significant impact on the environment?				X
b)	Conflict with an applicable plan, policy or regulation adopted for the purpose of reducing the emissions of greenhouse gases?				X

Background

The proposed zone change and tentative commercial buildings will not have an impact on greenhouse gas emissions.

Impact Discussion

- a) **No Impact.** Will not generate greenhouse gas emissions, either directly or indirectly, that may have a significant impact on the environment however, construction impacts would short term with minimal impacts. Any future development shall comply with the Imperial County Air Pollution Control District rules and regulations. The impacts are anticipated to be less than significant.
- b) **No Impact.** Will not conflict with an applicable plan, policy or regulation adopted for the purpose of reducing the emissions of greenhouse gases.

IX. HAZARDS AND HAZARDOUS MATERIALS – Would the project:					
		Potentially Significant Issues	Potentially Significant Unless Mitigation Incorporated	Less Than Significant Impact	No Impact
a)	Create a significant hazard to the public or the environment through the routine transport, use, or disposal of hazardous materials?			X	
b)	Create a significant hazard to the public or the environment through reasonable foreseeable upset and accident conditions involving the release of hazardous materials into the environment?				X
c)	Emit hazardous emissions or handle hazardous or acutely hazardous materials, substances, or waste within a quarter-mile of an existing or proposed school?				X
d)	Be located on a site, which is included on a list of hazardous materials sites compiled pursuant to Government Code Section 65962.5 and, as a result, would it create a significant hazard to the public or the environment?				X
e)	For a project located within an airport land use plan or, where such a plan has not been adopted, within two miles of a public airport or public use airport, would the project result in a safety hazard for people residing or working in the project area?				X
f)	For a project within the vicinity of a private airstrip, would the project result in a safety hazard for people residing or working in the project area?				X
g)	Impair implementation of or physically interfere with an adopted emergency response plan or emergency evacuation plan?				X
h)	Expose people or structures to a significant risk of loss, injury or death involving wildland fires including where wildlands are adjacent to urbanized areas or where residences are intermixed with wildlands?				X

Background

The proposed zone change and project is for tentative commercial uses and buildings along Highway 86 within the City of Imperial. The project is not going to bring nor generate any hazardous materials or uses to the area.

Impact Discussion

- a) **Less Than Significant Impact.** Will not create a significant hazard to the public or the environment through the routine transport, use, or disposal of hazardous materials. The project area may be impacted by aerial application using pesticide spray application on the existing and surrounding farm ground. Additionally, the project area may contain hazardous material that are used for abatement of weeds and insects; however, the applicant does not intend to change the current use of the parcel and therefore, any hazardous material impacts would be maintained at a level less than significant.

- b) **No Impact.** Will not create a significant hazard to the public or the environment through reasonable foreseeable upset and accident conditions involving the release of hazardous materials into the environment
- c) **No Impact.** Will not emit hazardous emissions or handle hazardous or acutely hazardous materials, substances, or waste within a quarter-mile of an existing or proposed school.
- d) **No Impact.** Will not create a significant hazard to the public or the environment. The project site is not located on a site included on a list of hazardous material sites; therefore, no impact expected.
- e) **No Impact.** Will not result in a safety hazard for people residing or working in the project area
- f) **No Impact.** Will not result in a safety hazard for people residing or working in the project area.
- g) **No Impact.** Will not impair implementation of or physically interfere with an adopted emergency response plan or emergency evacuation plan.
- h) **No Impact.** Will not expose people or structures to a significant risk of loss, injury or death involving wildland fires including where wildlands are adjacent to urbanized areas or where residences are intermixed with wildlands. The project site is not located in an area susceptible to wildland fires, therefore, no impact is expected.

X. HYDROLOGY AND WATER QUALITY – Would the project:					
		Potentially Significant Issues	Potentially Significant Unless Mitigation Incorporated	Less Than Significant Impact	No Impact
a)	Violate any water quality standards or waste discharge requirements?			X	
b)	Substantially deplete groundwater supplies or interfere substantially with groundwater recharge such that there would be a net deficit in aquifer volume or a lowering of the local groundwater table level (e.g., the production rate of pre-existing nearby wells would drop to a level which would not support existing land uses or planned uses for which permits have been granted)?				X
c)	Substantially alter the existing drainage pattern of the site or area, including through the alteration of the course of a stream or river, in a manner which would result in substantial erosion or situation on- or off-site?				X
d)	Substantially alter the existing drainage pattern of the site, including through the alteration of the course of a stream or river, in a manner which would result in flooding on- or off-site?				X
e)	Create or contribute runoff water, which would exceed the capacity of existing or planned storm water drainage systems or provide substantial additional sources of polluted runoff?				X
f)	Otherwise substantially degrade water quality?				X
g)	Place housing within a 100-year flood hazard area as mapped on a Flood Hazard Boundary or Flood Insurance Rate Map or other flood hazard delineation map?				X
h)	Place within a 100-year flood area structures which would impede or redirect the flood flows?				X

i)	Expose people or structures to a significant risk of loss, injury or death involving flooding, including flooding as a result of the failure of a levee or dam?				X
j)	Inundation, mud flow or water run-off?				X

Background

The proposed project will not create a detrimental impact on water resources within the city. If any unforeseen issues arise, the applicant will have to mitigate them during the building permitting process.

The Project site presently consists of vacant land with sparse vegetation. Therefore potential hazards for slope instability are unlikely. The increase in commercial density will increase the existing rates of runoff due to increased sealed surface areas. The incorporation of an adequate drainage management plan will help minimize any substantial risk of erosion or situation on or off-site. The drainage plans are subject to review by the City’s Public Services Department & Engineering Consultants, for consistency with City Standards.

A drainage report will be prepared to adequately assess the potential for adverse hydrological and drainage effects associated with short-term construction and longer-term operation of the proposed project. Findings and recommendations from the prepared Hydrology report will further be incorporated as mitigation measures for the project. Site development would include clearing and grubbing of vegetation, site grading, underground utility installation and construction of retention basins.

Impact Discussion

- a) **Less Than Significant Impact.** Will not violate any water quality standards or waste discharge requirements. No discharge of any industrial or process wastewater is proposed, but if the applicant commences to discharge any industrial or processed wastewater, the applicant will need to work the Regional Water Quality Control Board for permitting said discharge. However, less than significant impacts are anticipated. Implementation of the proposed Project may result in short term and long term changes to site drainage characteristics. Preparation of a Stormwater Pollution Prevention Plan (SWPPP) would be required for the proposed Project site to ensure consistency with all applicable water quality standards as well as implementation of Best Management Practices (BMPs).
- b) **No Impact.** The proposed Project would rely on municipal water for both short-term and long-term operation. The proposed zone change and multifamily apartment complex will not substantially deplete groundwater; therefore, no impacts are expected.
- c) **No Impact.** The proposed zone change and future commercial uses will not substantially alter the existing drainage pattern of the site or area, resulting in substantial erosion or siltation on- or off-site, therefore, no impacts are expected. The soils at the site are subject to wind and water erosion, especially during Project construction. However, implementation of the SWPPP and BMPs would reduce impacts to less than significant. Areas not paved or constructed would be landscaped in accordance with City of Imperial requirements. Therefore, the likelihood of soil erosion or loss of topsoil would be minimized.
- d) **No Impact.** The proposed zone change and commercial complex will not substantially alter the existing drainage patterns or increase the rate or amount of surface runoff, resulting in flooding on- or off-site; therefore, no impact are expected. Additionally, Imperial County Public Works will require that a drainage and grading plan/study/letter be submitted at the time of development. Therefore, any impacts are expected to be less than significant.
- e) **No Impact.** The proposed zone change and commercial complex will not create or contribute runoff water, which would exceed the capacity of existing or planned storm water drainage systems or provide substantial additional sources of polluted runoff. The proposed on-site detention basin and landscaped areas will

accommodate the water run-off from the Project site. Construction activities on the project site would be subject to Best Management Practices (BMP's) and a Storm Water Pollution Prevention Plan (SWPPP) to minimize pollution on and off-site

- f) **No Impact.** The proposed zone change and commercial complex will not otherwise substantially degrade water quality, and; therefore, no impact is expected.
- g) **No Impact.** Will not place housing within a 100-year flood hazard area as mapped on a Flood Hazard Boundary or Flood Insurance Rate Map or other flood hazard delineation map. Per FEMA Flood Map #06025C1700C the project site is not located with a flood area. Therefore, no impact is expected.
- h) **No Impact.** Will not place within a 100-year flood area structures which would impede or redirect the flood flows and would not require the placement of structures within 100-year flood hazard area, which would impede or redirect flood flow, therefore, no impact is expected.
- i) **No Impact.** Will not expose people or structures to a significant risk of loss, injury or death involving flooding, including flooding as a result of the failure of a levee or dam.
- j) **No Impact.** The proposed zone change and future commercial uses would not expose people or structures to a significant risk or lost, injury or death involving inundation by seiche, tsunami, or mudflow, therefore, no impact is expected.

XI. LAND USE AND PLANNING – Would the proposal:					
		Potentially Significant Issues	Potentially Significant Unless Mitigation Incorporated	Less Than Significant Impact	No Impact
a)	Physically divide an established community?				X
b)	Conflict with any applicable land use plan, policy, or regulation of an agency with jurisdiction over the project (including, but not limited to, the general plan, specific plan, local coastal program, or zoning ordinance) adopted for the purpose of avoiding or mitigating an environmental effect?				X
c)	Conflict with any applicable habitat conservation plan or natural community conservation plan?				X

Background

The proposed project will serve as infill in the community and the City of Imperial because it is to be located on vacant parcels. The proposed zone change is consistent General Plan's Land Use Elements goals, objectives, and policies.

Impact Discussion

- a) **No Impact.** The proposed project will not physically divide an established community.
- b) **No Impact.** Will not conflict with any applicable land use plan, policy, or regulation of an agency with jurisdiction over the project (including, but not limited to, the general plan, specific plan, local coastal program, or zoning ordinance) adopted for the purpose of avoiding or mitigating an environmental effect.
- c) **No Impact.** The proposed Project would not conflict with any applicable habitat conservation plan or natural community conservation plan because the site is currently used as a residential property and is not identified as suitable habitat for plan and/or animal species.

XII. MINERAL RESOURCES – Would the project:				
	Potentially Significant Issues	Potentially Significant Unless Mitigation Incorporated	Less Than Significant Impact	No Impact
a) Result in the loss of availability of a known mineral resource that would be of value to the region and the residents of the state?				X
b) Result in the loss of availability of a locally-important mineral resource recovery site delineated on a local general plan, specific plan or other land use plan?				X

Background

The project is not located in an area that is considered by the State of California a “mineral resource” source, thus it will not impact this item.

Impact Discussion

- a) **No Impact.** Will not result in the loss of availability of a known mineral resource that would be of value to the region and the residents of the state. The proposed zone change and tentative commercial uses will not remove mineral resources on-site; therefore, no impact expected.
- b) **No Impact.** The proposed zone change and proposed commercial uses not result in the loss of availability of a locally-important mineral resource recovery site delineated on a local general plan, specific plan or other land use plan.

XIII. NOISE – Would the project result in:				
	Potentially Significant Issues	Potentially Significant Unless Mitigation Incorporated	Less Than Significant Impact	No Impact
a) Exposure of persons to or generation of noise levels in excess of standards established in the local general plan or noise ordinance, or applicable standards of other agencies?				X
b) Exposure of persons to or generation of excessive ground borne vibration or ground borne noise levels?				X
c) A substantial permanent increase in ambient noise levels in the project vicinity above levels existing without the project?				X
d) A substantial temporary or periodic increase in ambient noise levels in the project vicinity above levels existing without the project?				X
e) For a project located within an airport land use plan or where such a plan has not been adopted, within two miles of a public airport or public use airport, would the project expose people residing or working in the project area to excessive noise levels?				X
f) For a project within the vicinity of a private airstrip, would the project expose people residing or working in the project area to excessive noise levels?				X

Background

The proposed project will comply with the noise element for that zone.

Impact Discussion

- a) **No impact.** The proposed project will not expose persons to or generate noise levels in excess of standards established in the local general plan or noise ordinance, or applicable standards of other agencies. The proposed project is not expected to create substantial permanent increase in ambient noise levels in the project vicinity above levels existing without the project. Therefore, less than significant impacts are expected.
- b) **No Impact.** The proposed project will not expose persons to or generate excessive ground borne vibration or ground borne noise levels.
- c) **No impact.** The zone change will not create a substantial permanent increase in ambient noise levels in the project vicinity above levels existing without the project. The project is not expected to create substantial permanent increase in ambient noise levels in the project vicinity above levels existing without the project. Therefore, less than significant impacts are expected.
- d) **No impact.** Will not create a substantial temporary or periodic increase in ambient noise levels in the project vicinity above levels existing without the project. The proposed zone change, is not expected to create a substantial temporary or periodic increase in ambient noise levels in the project vicinity above levels existing without the project. Therefore less than significant impacts are expected. Construction of the proposed Project could result in an increase in the existing ambient noise environment. Construction levels at the nearest noise sensitive locations would be approximately 89 dBA. Additionally, phased development of the proposed Project would result in increased noise levels compared to pre-construction phases. Mitigation would be required to minimize construction noise in these areas. These measures include, but are not limited to: limiting the hours of construction and use of mufflers on construction equipment
- e) **No impact.** Will not expose people residing or working in the project area to excessive noise levels. According to the Imperial County Airport Land Use Compatibility Plan, the Project site is located within the “**D**” Zone which is within the “Other Airport Environs” location. According to the Plan, there is negligible risk to residents in this Zone, but there is potential for annoyance from overflights. There are no limits within this Zone in regard to density and no requirements for open land. An aviation easement exists on the project site and would be continued with the resubdivision.
- f) **No impact.** The project is not located near a private airstrip. The proposed project site is not within the vicinity of a private airport nor is it within the close vicinity of a private airstrip. Therefore, the proposed water well will not result in any

XIV. POPULATION AND HOUSING – Would the project:					
		Potentially Significant Issues	Potentially Significant Unless Mitigation Incorporated	Less Than Significant Impact	No Impact
a)	Induce substantial population growth in an area either directly (for example, by proposing new homes and businesses) or indirectly (for example, through extension of roads or other infrastructure)?			X	
b)	Displace substantial numbers of existing housing, necessitating the construction of replacement housing elsewhere?				X
c)	Displace substantial numbers of people, necessitating the construction of replacement housing elsewhere?				X

Background

The zone change and commercial uses will not contribute to permanent population growth for the City. The uses are proposed to be commercial in nature and not offer permanent residences to individuals.

Impact Discussion

- a) **Less than Significant Impact.** The zone change would not induce substantial population growth in the area either directly or indirectly, the parcels are zoned for R-1 (Single-Family Residential) but a proposed Public Facility Use for a school site. While there would be impacts, the impacts would appear to be less than significant.
- b) **No Impact.** The project is proposed to be developed on currently vacant land and would not displace substantial numbers of exiting housing, necessitating the construction of replacement housing elsewhere; therefore, no impact is expected.
- c) **No Impact.** The land that the project is proposed to be developed on is currently vacant. The proposed development will not displace substantial numbers of people necessitating the construction or replacement housing elsewhere; therefore, no impact is expected.

<i>XV. PUBLIC SERVICES:</i>				
	Potentially Significant Issues	Potentially Significant Unless Mitigation Incorporated	Less Than Significant Impact	No Impact
a) Would the project result in substantial adverse physical impacts associated with the provision of new or physically altered governmental facilities, need for new or physically altered governmental facilities, the construction of which could cause significant environmental impacts, in order to maintain acceptable service ratios, response times or other performance objectives for any of the public services:				
1) Fire protection?			X	
2) Police protection?			X	
3) Schools?			X	
4) Parks?			X	
5) Other public facilities?			X	

Background

The project will not result in substantial adverse physical impacts associated with the provision of new or physically altered governmental facilities, need for new or physically altered governmental facilities, the construction of which could cause significant environmental impacts, in order to maintain acceptable service ratios, response times or other performance objectives for any of the public services.

Impact Discussion

- 1. **Less Than Significant Impact.** At the time of building permit processing the applicant will comply with any requirements needed by the fire department. The proposed zone change is not expected to result in substantial impacts on fire protection; however, any new impacts would be less than significant. The installation of fire hydrants within the Project site will offer increased fire protection to the Project area and therefore the impact should be less than significant.

2. **Less Than Significant Impact.** The police department did not impose nor express any safety concern issues regarding the proposed development. The proposed zone change is not expected to have result in substantial impacts on police protection; any new impacts would be less than significant.
3. **Less Than Significant Impact.** The developer is required to pay “school fees” to help mitigate any potential increase in service the project may create. The proposed zone change is not expected to have an impact on schools; therefore, any new impacts would be less than significant.
4. **Less Than Significant Impact.** The proposed zone change and commercial uses are not expected to create a substantial impact on parks; therefore, less than significant impact would be expected.
5. **Less Than Significant Impact.** There are no foreseeable impacts to other public facilities at the time of this evaluation based on the proposed use. The proposed zone change is not expected to create a substantial impact on other public facilities; therefore, less than significant impacts would be expected.

XVI. RECREATION:				
	Potentially Significant Issues	Potentially Significant Unless Mitigation Incorporated	Less Than Significant Impact	No Impact
a) Would the project increase the use of the existing neighborhood and regional parks or other recreational facilities such that substantial physical deterioration of the facility would occur or be accelerated?				X
b) Does the project include recreational facilities or require the construction or expansion of recreational facilities which might have an adverse effect on the environment?				X

Background

The proposed zone change and commercial developments will have open space areas but will not have an impact on existing recreational needs nor increase the need for more recreational space because the proposed uses are commercial in nature.

Impact Discussion

- a) **No Impact.** The proposed zone change will not increase the use of the existing neighborhood and regional parks or other recreational facilities.
- b) **No Impact.** The proposed zone change and commercial uses do not include or require the construction of recreational facilities; therefore, no impact is expected.

XVII. TRANSPORTATION – Would the project:				
	Potentially Significant Issues	Potentially Significant Unless Mitigation Incorporated	Less Than Significant Impact	No Impact
a) Cause an increase in traffic, which is substantial in relation to the existing traffic load and capacity of the street system (i.e., result in a substantial increase in either the number of vehicle trips, the volume to capacity ratio on roads or congestion at intersections)?			X	

b)	Exceed, either individually or cumulatively, a level of service standard established by the county congestion/management agency for designated roads or highways?				X
c)	Result in a change in air traffic patterns, including either an increase in traffic levels or a change in location that result in substantial safety risks?				X
d)	Substantially increase hazards due to a design feature (e.g., sharp curves or dangerous intersections) or incompatible uses (e.g., farm equipment)?				X
e)	Result in inadequate emergency access?				X
f)	Result in insufficient parking capacity?				X
g)	Conflicts with adopted policies, plans, programs, supporting alternative transportation (e.g., bus turnouts, bicycle racks)?				X
h)	Conflicts or be inconsistent with CEQA Guidelines section 15064.3, subdivision (b)?				X

Background

The proposed zone change is from the existing R-1(Single-Family Residential) to a C-2 (General Commercial) zoning. The tentative commercial projects will have to comply with all development requirements the City of Imperial formulates to mitigate potential traffic congestion at the time of Site Plan Review. The project will have to comply with all development requirements the City of Imperial formulates to mitigate potential traffic congestion that may result before or after the development is constructed.

If the subject site were to be developed with a Public Facilities use as planned in the initial development proposals For a school site, the parcels could generate up to 5270 average daily trips (ADT’s). If the zone is changed to “C-2”, the site could generate up to 5450 ADT’s based on a the maximum density and lot coverage permitted within the zone, which could be less since there is not an official proposal project amount on behalf of the applicant. All ADT projections are based on San Diego Association of Governments (SANDAG) Trip Generation Rates. The developer must incorporate, provide and install all traffic mitigation measures that are formulated by the City of Imperials Traffic Commission and approved by the City engineer and developer's engineer and that are within the Traffic Study for Morningstar Subdivision before building permits are obtained and/or certificates of occupancy. Developer provided a traffic study and mitigation measures were identified and are made part of.

Impact Discussion

- a) **Less than Significant Impact.** The project is proposed to be in a zoning district that can with stand the potential generation of traffic. Measures will be implemented at the time of construction to prevent any type of potentially adverse effects in regards to traffic. The proposed zone change is not expected to create a substantial impact to surrounding roads; however any new impacts would appear to be less than significant. The tentative commercial project could potentially increase average daily trips by 180 ADTs, but all roadway segments and intersections will continue to operate at LOS C or better.
- b) **No Impact.** The project will not exceed, either individually or cumulatively, a level of service standard established by the county congestion/management agency for designated roads or highways.
- c) **No Impact.** Will not result in a change in air traffic patterns, including either an increase in traffic levels or a change in location that result in substantial safety risks.
- d) **No Impact.** The proposed project will not create any exposure to hazardous materials.

- e) **No Impact.** The project will not result in inadequate emergency access.
- f) **No Impact.** The proposed development will have to comply with the City of Imperial’s development standards in all aspects. The development must have enough parking for the proposed use and it will not result in insufficient parking.
- g) **No Impact.** The proposed project will not conflicts with adopted policies, plans, programs, supporting alternative transportation
- h) **No Impact.** The project will not have an adverse effect nor be inconsistent with CEQA Guidelines section 15064.3, subdivision (b).

XVIII. TRIBAL CULTURAL RESOURCES – Would the project:				
	Potentially Significant Issues	Potentially Significant Unless Mitigation Incorporated	Less Than Significant Impact	No Impact
a) Would the project cause a substantial adverse change in the significance of a tribal cultural resource, defined in Public Resources Code section 21074 as either a site, feature, place, cultural landscape that is geographically defined in terms of the size and scope of the landscape, sacred place, or object with cultural value to a California Native American tribe, and that is:				X
b) Listed or eligible for listing in the California Register of Historical Resources, or in a local register of historical resources as defined in Public Resources Code section 5020.1 (k), or				X
c) A resource determined by the lead agency, in its discretion and supported by substantial evidence, to be significant pursuant to criteria set forth in subdivision of Public Resource Code Section 5024.1, the lead agency shall consider the significance of the resource to a California Native American tribe				X

Background

The commercial project is proposed to be on vacant land located within an urbanized area. The parcels are zoned for Residential Uses. There have not been reports of the parcels nor the area to have any ties to tribal culture or resources.

Impact Discussion

- a) **No Impact.** The project is proposed to be on vacant land. Based on Figure 6 Known Areas of Native American Sensitivity of the Conservation and Open Space Element of the Imperial County General Plan, the project site is not located with any sensitive area.
- b) **No Impact.** The land is vacant and not listed or eligible for listing in the California Register of Historical Resources, or in a local register of historical resources as defined in Public Resources Code section 5020.1 (k). The proposed project would not cause a substantial change in the significance of a tribal cultural resource and no historical resources have been identified as significant in the project area.

- c) **No Impact.** The project has not been determined to be significant pursuant to criteria set forth in subdivision of Public Resource Code Section 5024.1, the lead agency shall consider the significance of the resource to a California Native American tribe.

XIX. UTILITIES AND SERVICE SYSTEMS – Would the project:					
		Potentially Significant Issues	Potentially Significant Unless Mitigation Incorporated	Less Than Significant Impact	No Impact
a)	Exceed wastewater treatment requirements of the applicable Regional Water Quality Control Board?				X
b)	Require or result in the construction of new storm water or water treatment facilities or expansion of existing facilities, the construction of which could cause significant environmental effects?				X
c)	Require or result in the construction of new storm water drainage facilities or expansion of existing facilities, the construction of which could cause significant environmental effects?				X
d)	Have sufficient water supplies available to serve the project from existing entitlements and resources, or are new or expanded entitlements needed?				X
e)	Result in a determination by the wastewater treatment provider which serves or may serve the project that it has adequate capacity to serve the project's projected demand in addition to the provider's existing commitments?				X
f)	Be served by a landfill with sufficient permitted capacity to accommodate the project's solid waste disposal needs?				X
g)	Comply with federal, state, and local statutes and regulations related to solid waste?				X

Background

The project is a proposed zone change with tentative commercial developments. The applicant is aware and subject to conditions of approval to ensure that the project and city are provided and served with all the necessary utilities to properly function and meet all local and state regulation requirements when it comes to water and sewer. The Project will require water and sewer line extensions connecting to the existing water and wastewater infrastructure, as well as the construction of new infrastructure.

Impact Discussion

- a) **No Impact.** The project will not exceed wastewater treatment requirements of the applicable Regional Water Quality Control Board. The proposed zone change will not exceed wastewater treatment requirements of the Regional Water Quality Control Board; therefore, no impacts are expected.
- b) **No Impact.** The project will not require new facilities to be constructed because of the use. The proposed zone change will not result in the construction of new water or water treatment facilities or expansion of existing facilities. Therefore, no impact is expected.
- c) **No Impact.** None of the proposed construction will cause environmental constraints. The proposed zone change will not result in the construction of a new storm water drainage facilities or expansion of existing facilities; therefore, no impact is expected.

- d) **No Impact.** The proposed project will have sufficient water supplies available to serve the project from existing entitlements and resources, or are new or expanded entitlements needed.
- e) **No Impact.** The proposed zone change will not result in a determination by a wastewater treatment provider that services or may service the project that it does not have adequate capacity to the project's projected demands in additions to the provider's existing commitments. At the time of the Building Permit application process, the developer will supply the city with a Hydrology flow test, to ensure the use will have adequate water supply and if not the developer will mitigate the issue.
- f) **No Impact.** The project will be served by a landfill with sufficient capacity to accommodate the project's solid waste disposal needs.
- g) **No Impact.** The project will comply with federal, state, and local statutes and regulations related to solid waste.

XX. WILDFIRE – If located near or near state responsibility areas or lands classified as very high fire hazard severity zones, Would the project:				
	Potentially Significant Issues	Potentially Significant Unless Mitigation Incorporated	Less Than Significant Impact	No Impact
a) Substantially impair an adopted emergency response plan or emergency evacuation plan?				X
b) Due, to slope, prevailing winds, and other factors, exacerbate wildfire risks, and thereby expose project occupants to, pollutant concentrations from a wildfire or the uncontrolled spread of a wildfire?				X
c) Require the installation or maintenance of associated infrastructure (such as roads, fuel breaks, emergency water sources, power lines or other utilities) that may exacerbate fire risk or that may result in temporary or ongoing impacts to the environment?				X

Background

The City of Imperial is part of the Imperial County, which is within the State of California. We are the only county, that has not been assessed by the state of California for “WILDFIRE” threats.

Impact Discussion

- a) **No Impact.** No risk of wildfire at the proposed projects location.
- b) **No Impact.** No risk of wildfire at the proposed projects location.
- c) **No Impact.** No risk of wildfire at the proposed projects location.

XXI. MANDATORY FINDINGS OF SIGNIFICANCE				
a)	Does the project have the potential to degrade the quality of the environment, substantially reduce the habitat of a fish or wildlife species, cause a fish or wildlife population to drop below self-sustaining levels, threaten to eliminate a plant or animal community, reduce the number or restrict the range of a rare or endangered plant or animal, or eliminate important examples of the major periods of California history or prehistory?			X
b)	Does the project have impacts that are individually limited, but cumulatively considerable? (“Cumulatively considerable” means that the incremental effects of a project are considerable when viewed in connection with the effects of past projects, the effects of other current projects, and the effects of probable future projects.)			X
c)	Does the project have environmental effects that will cause substantial adverse effects on human beings, either directly or indirectly?			X

Background

The project is a proposed zone change from R-1 (Single-Family Residential) to C-2 (Commercial General) To allow for the development of commercial uses on vacant land.

Impact Discussion

- a) **No Impact.** The project is proposed to be on parcels that are currently vacant.
- b) **No Impact.** The does not have impacts that are individually limited, but cumulatively considerable.
- c) **No Impact.** The project does not have environmental effects that will cause substantial adverse effects on human beings, either directly or indirectly.

SOURCE REFERENCES	
The following documents were used as sources of factual data and are hereby incorporated as part of this Environmental Checklist. Because of the voluminous nature of the documents, copies of the following documents are not distributed with this document but may be obtained from the City of Imperial.	
A	City of Imperial Zoning Ordinance
B	City of Imperial General Plan
C	City of Imperial Service Area Plan
D	Air Pollution Control District CEQA Air Quality Handbook
E	County of Imperial Airport Land Use Compatibility Plan

Heritage at Dahlia Ranch

Traffic Study

Prepared for:

Heritage at Dahlia Ranch, LLC
341 Crown Court
Imperial, CA 92251

Prepared by:

Marc Mizuta, PE, TE, PTOE



5694 Mission Center Road, #602-121
San Diego, CA 92108

November 2021

TABLE OF CONTENTS

1	INTRODUCTION	1
1.1	PROJECT DESCRIPTION.....	1
2	ANALYSIS APPROACH AND METHODOLOGY	6
2.1	STUDY AREA.....	6
2.2	ANALYSIS SCENARIOS.....	7
2.3	METHODOLOGY.....	7
2.3.1	<i>Intersection Level of Service Analysis</i>	7
2.3.2	<i>Roadway Segment Analysis</i>	8
2.4	IMPROVEMENT CRITERIA	9
3	EXISTING CONDITIONS.....	10
3.1	ROADWAY NETWORK	10
3.2	TRAFFIC VOLUMES.....	12
3.3	INTERSECTION ANALYSIS	15
3.4	ROADWAY SEGMENT ANALYSIS.....	16
4	PROJECT TRAFFIC	17
4.1	TRIP GENERATION.....	17
4.2	TRIP DISTRIBUTION AND ASSIGNMENT	19
4.3	PROJECT TRIP ASSIGNMENT.....	30
5	CUMULATIVE PROJECT TRAFFIC	41
5.1	CUMULATIVE PROJECTS.....	41
6	OPENING YEAR 2023.....	45
6.1	ROADWAY NETWORK	45
6.2	TRAFFIC VOLUMES.....	45
6.3	INTERSECTION ANALYSIS	45
6.4	ROADWAY SEGMENT ANALYSIS.....	53
7	OPENING YEAR 2024	54
7.1	ROADWAY NETWORK	54
7.2	TRAFFIC VOLUMES.....	54
7.3	INTERSECTION ANALYSIS	54
7.4	ROADWAY SEGMENT ANALYSIS.....	62
8	OPENING YEAR 2026	63
8.1	ROADWAY NETWORK	63
8.2	TRAFFIC VOLUMES.....	63
8.3	INTERSECTION ANALYSIS	63
8.4	ROADWAY SEGMENT ANALYSIS.....	71
9	OPENING YEAR 2028.....	72
9.1	ROADWAY NETWORK	72
9.2	TRAFFIC VOLUMES.....	72
9.3	INTERSECTION ANALYSIS	72
9.4	ROADWAY SEGMENT ANALYSIS.....	80

LIST OF FIGURES

Figure 1-1 Project Vicinity Map 2
 Figure 1-2 Site Plan 3
 Figure 1-3 Phasing Plan 4
 Figure 3-1 Existing Intersection Geometrics 11
 Figure 3-2 Existing Conditions Traffic Volumes 13
 Figure 4-1 Phase 1 Project Trip Distribution 20
 Figure 4-2 Phase 2 Project Trip Distribution 22
 Figure 4-3 Phase 3 (Multi-Family) Project Trip Distribution 24
 Figure 4-4 Phase 3 (Commercial/Retail) Project Trip Distribution 26
 Figure 4-5 Phase 4 Project Trip Distribution 28
 Figure 4-6 Phase 1 Trip Assignment 31
 Figure 4-7 Phase 2 Trip Assignment 33
 Figure 4-8 Phase 3 (Multi-Family) Trip Assignment 35
 Figure 4-9 Phase 3 (Commercial/Retail) Trip Assignment 37
 Figure 4-10 Phase 4 Trip Assignment 39
 Figure 5-1 Cumulative Project Location Map 42
 Figure 5-2 Cumulative Project Traffic Volumes – Year 2026 43
 Figure 5-3 Cumulative Project Traffic Volumes – Year 2028 44
 Figure 6-1 Opening Year 2023 Phase 1 Intersection Geometrics 46
 Figure 6-2 Opening Year 2023 Baseline Traffic Volumes 48
 Figure 6-3 Opening Year 2023 Plus Phase 1 Project Traffic Volumes 50
 Figure 7-1 Opening Year 2024 Phase 2 Intersection Geometrics 55
 Figure 7-2 Opening Year 2024 Baseline Traffic Volumes 57
 Figure 7-3 Opening Year 2024 Plus Phases 1 & 2 Project Traffic Volumes 59
 Figure 8-1 Opening Year 2026 Phase 3 Intersection Geometrics 64
 Figure 8-2 Opening Year 2026 Baseline Traffic Volumes 66
 Figure 8-3 Opening Year 2026 Plus Phases 1 to 3 Project Traffic Volumes 68
 Figure 9-1 Opening Year 2028 Phase 4 Intersection Geometrics 73
 Figure 9-2 Opening Year 2028 Baseline Traffic Volumes 75
 Figure 9-3 Opening Year 2028 Plus Phases 1 to 4 Project Traffic Volumes 77

LIST OF TABLES

Table 2-1 LOS Criteria for Intersections 8
 Table 2-2 LOS Criteria for Roadway Segments 9
 Table 3-1 Existing Peak Hour Intersection LOS Summary 15
 Table 3-2 Existing Roadway Segment LOS Summary 16
 Table 4-1 Trip Generation Rates 17
 Table 4-2 Weekday Trip Generation Summary 18
 Table 6-1 Opening Year 2023 Peak Hour Intersection LOS Summary 52
 Table 6-2 Opening Year 2023 Roadway LOS Summary 53
 Table 7-1 Opening Year 2024 Peak Hour Intersection LOS Summary 61
 Table 7-2 Opening Year 2024 Roadway LOS Summary 62
 Table 8-1 Opening Year 2026 Peak Hour Intersection LOS Summary 70
 Table 8-2 Opening Year 2026 Roadway LOS Summary 71
 Table 9-1 Opening Year 2028 Peak Hour Intersection LOS Summary 79
 Table 9-2 Opening Year 2028 Roadway LOS Summary 80

APPENDICES

Appendix A	SR-86 Relinquishment Map
Appendix B	Existing Traffic Volume Data
Appendix C	Intersection LOS Worksheets
Appendix D	Internal Capture Worksheets
Appendix E	SCAG Profile of Imperial County Report Excerpts

I INTRODUCTION

This traffic study evaluates the traffic conditions associated with the proposed Heritage at Dahlia Ranch project (herein referred to as “the Project”) generally located north of Neckel Road, south of Ralph Road, east of La Brucherie Road, and west of Imperial Avenue in Imperial, CA. **Figure 1-1** shows the location of the project site within the study area. The traffic analyses have been prepared in accordance with the *County of Imperial Department of Public Works Traffic Study and Report Policy, June 29, 2007 (County Guidelines)* and consistent with the countywide goals toward the Congestion Management Program (CMP) in Imperial County.

I.1 Project Description

The Project consists of developing the vacant land into a mixture of residential single-family homes and apartments and various commercial/retail. The project would be constructed over four phases consisting of the following:

- Phase 1: 133 single family residential units
- Phase 2: 133 single family residential units
- Phase 3: 200 apartment units and 92,120 square feet (sf) of various commercial/retail
- Phase 4: 202 single-family residential units

Access for Phase 1 will be provided off Neckel Road. Upon the completing of Phase 2, a secondary access along La Brucherie Road will be constructed. During Phase 3, access to the apartments will be provided off Ralph Road. Access to the commercial/retail uses will be provided off Ralph Road and Imperial Avenue. The construction of the west leg of the La Brucherie Road & Project Driveway intersection will occur in Phase 4 to serve the residential units. **Figure 1-2** illustrates the proposed site plan. **Figure 1-3** illustrates the phasing plan for the Project.

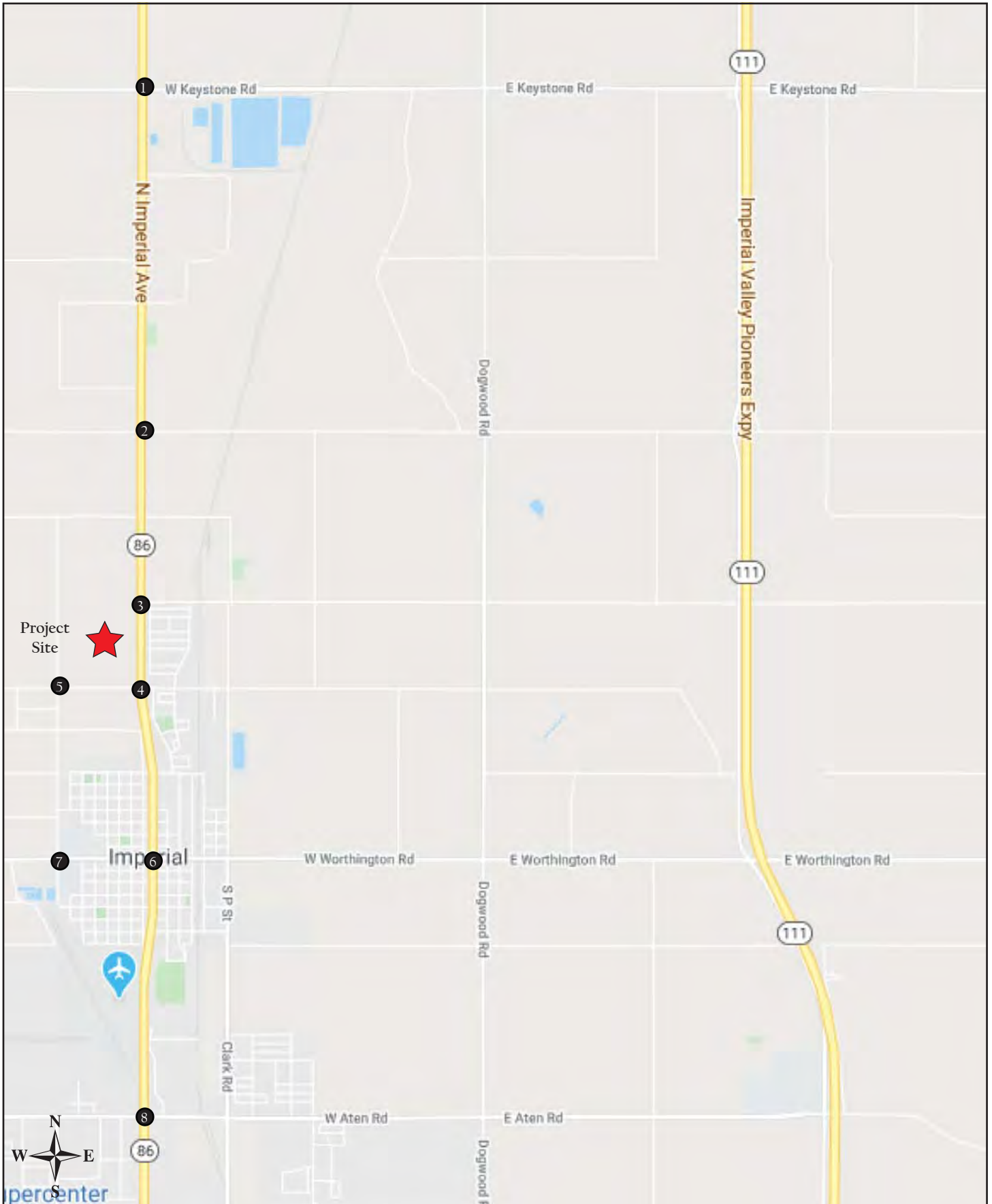

Heritage at Dahlia Ranch

Figure 1-1
Project Vicinity Map

MORNING STAR SUBDIVISION
TENTATIVE MAP - EAST PORTION

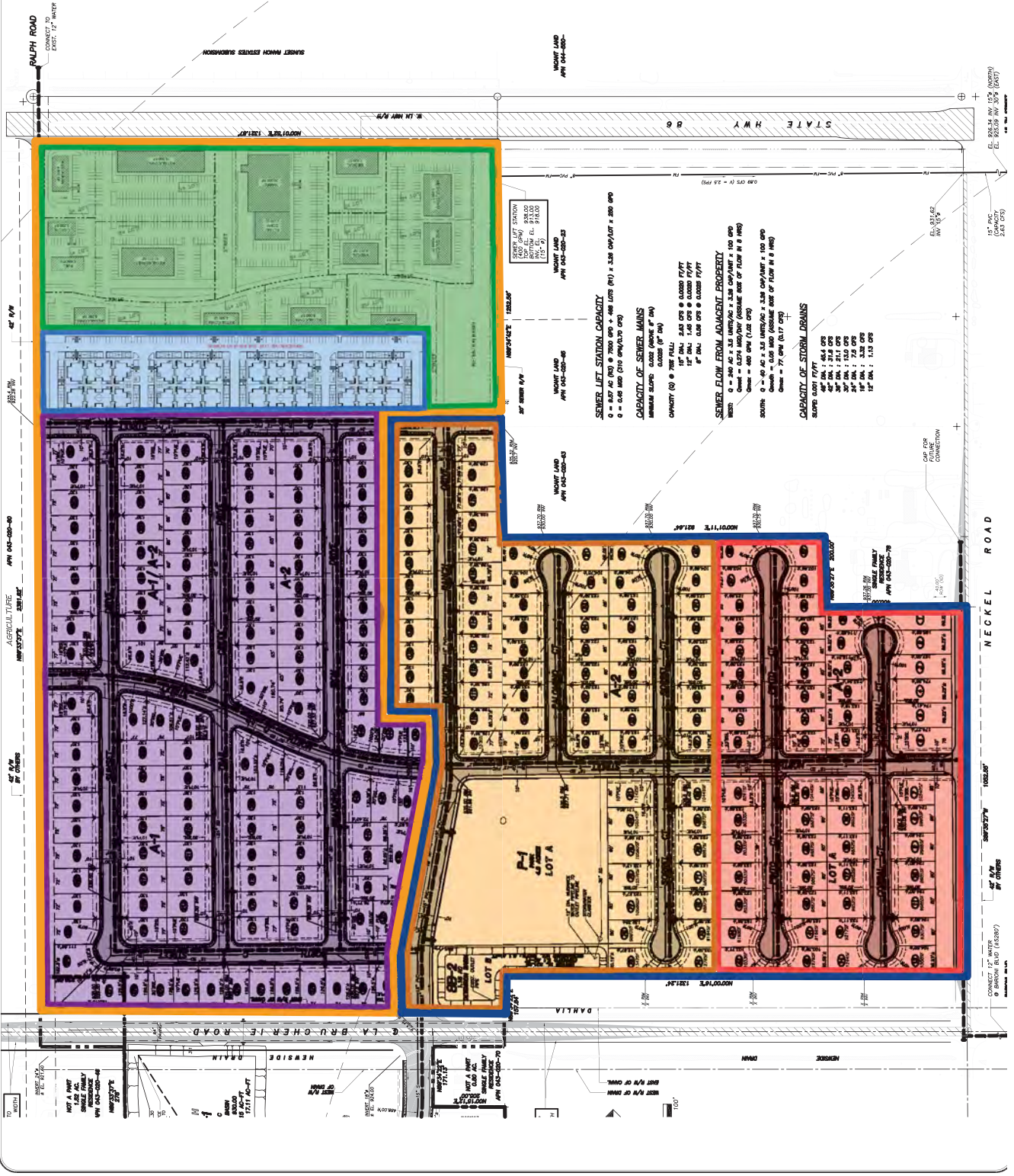

Heritage at Dahlia Ranch

Figure 1-2
Site Plan



LEGEND

	Phase 1
	Phase 2
	Phase 3
	Phase 1 Road Network
	Phase 2 Road Network
	Phase 3 Road Network



Heritage at Dahlia Ranch

Figure 1-3
Phasing Plan

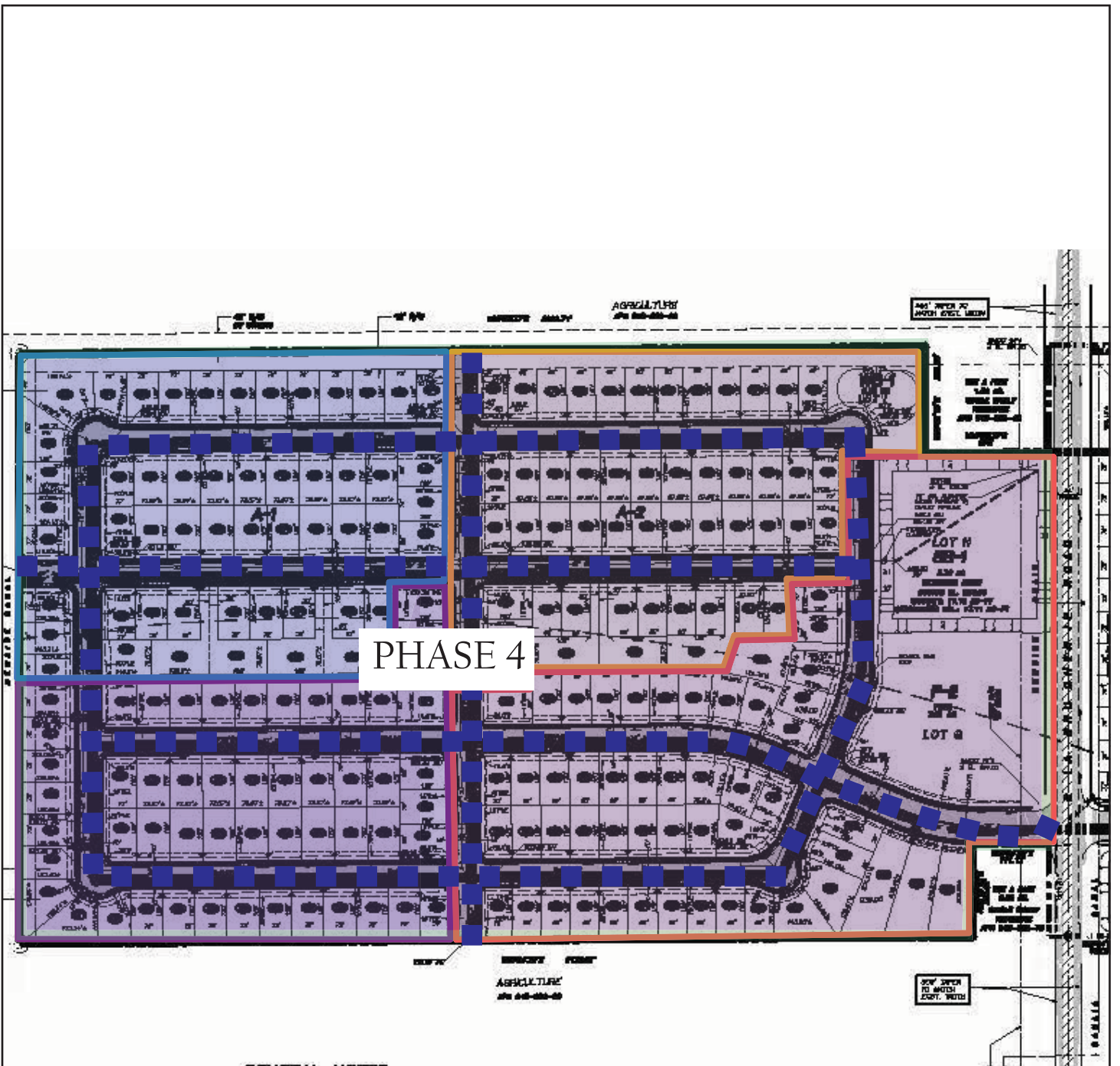

PHASE 4

LEGEND

- Phase 4
- Phase 4 Road Network



Heritage at Dahlia Ranch

Figure 1-3a
Phasing Plan

2 ANALYSIS APPROACH AND METHODOLOGY

This section summarizes the analysis approach and methodology used to evaluate the study intersections and roadway segments associated with the Project.

2.1 Study Area

This traffic study addresses potential operational impacts that could result from the addition of the Project traffic to the local circulation system.

The following intersections and roadway segments are included as part of the study area since they will carry majority of the project traffic:

Intersections

1. SR-86 & Keystone Road
2. SR-86 & Larson Road
3. Imperial Avenue & Ralph Road
4. Imperial Avenue & Neckel Road
5. La Brucherie Road & Neckel Road
6. Imperial Avenue & Worthington Road/Barioni Boulevard
7. La Brucherie Road & Worthington Road
8. Imperial Avenue & Aten Road
9. Project Driveway & Neckel Road (constructed in Phase 1)
10. La Brucherie Road & Project Driveway (constructed in Phase 2, expanded in Phase 4)
11. SFR Project Driveway & Ralph Road (constructed in Phase 3)
12. MFR Project Driveway & Ralph Road (constructed in Phase 3)
13. Retail Project Driveway & Ralph Road (constructed in Phase 3)
14. Imperial Avenue & Project Driveway (constructed in Phase 3)

Segments

1. SR-86 north of Keystone Road
2. SR-86 between Keystone Road and Larsen Road
3. SR-86 between Larsen Road and Ralph Road
4. Imperial Avenue between Ralph Road and Neckel Road
5. Imperial Avenue between Neckel Road and Worthington Road
6. Imperial Avenue between Worthington Road and Aten Road
7. Imperial Avenue south of Aten Road

2.2 Analysis Scenarios

The following scenarios were evaluated as part of the project:

- Existing Conditions: This scenario reflects the existing street network within the study area in the Year 2021.
- Opening Year 2023 Conditions: This scenario reflects the street network assumed to be in place in the Year 2023 and includes traffic from Phase 1 only and cumulative projects.
- Opening Year 2024 Conditions: This scenario reflects the street network assumed to be in place in the Year 2024 and includes traffic from Phases 1 and 2 and cumulative projects.
- Opening Year 2026 Conditions: This scenario reflects the street network assumed to be in place in the Year 2026 and includes traffic from Phases 1 through 3 and cumulative projects.
- Opening Year 2028 Conditions: This scenario reflects the street network assumed to be in place in the Year 2028 and includes traffic from Phases 1 through 4 and cumulative projects.

The traditional weekday peak-hour coinciding with the highest volume of traffic between 7:00 and 9:00 AM and between 4:00 and 6:00 PM was evaluated for each analysis scenario.

2.3 Methodology

2.3.1 Intersection Level of Service Analysis

Signalized and unsignalized intersection operations were analyzed with Synchro II software (Trafficware), using the methodologies outlined in the *Highway Capacity Manual 6th Edition (HCM6)*. The HCM methodology calculates delay, which corresponds to a particular LOS, to describe the overall operation of an intersection. Delay is a measure of driver and/or passenger discomfort, frustration, fuel consumption and lost travel time.

The LOS for unsignalized intersections is determined by the computed or measured control delay and is defined for each minor movement. At a one-way or two-way stop control intersection, the delay reported represents the worst movement, which is typically the left-turns from the minor street approach. The criteria for the LOS grade designations are provided in [Table 2-1](#).

Within the County of Imperial, the threshold for acceptable operating conditions for signalized and unsignalized intersections is LOS C or better.

Table 2-1
LOS Criteria for Intersections

LOS	LOS Criteria (sec/veh)		Description
	Signalized Intersections	Unsignalized Intersections	
A	≤10	≤10	EXCELLENT. Operations with very low delay and most vehicles do not stop.
B	>10 and ≤20	>10 and ≤15	VERY GOOD. Operations with good progression but with some restricted movements.
C	>20 and ≤35	>15 and ≤25	GOOD. Operations where a significant number of vehicles are stopping with some backup and light congestion.
D	>35 and ≤55	>25 and ≤35	FAIR. Operations where congestion is noticeable, longer delays occur, and many vehicles stop. The proportion of vehicles not stopping declines.
E	>55 and ≤80	>35 and ≤50	POOR. Operations where there is significant delay, extensive queuing, and poor progression.
F	>80	>50	FAILURE. Operations that are unacceptable to most drivers, when the arrival rates exceed the capacity of the intersection.

Source: *Highway Capacity Manual 6th Edition*

2.3.2 Roadway Segment Analysis

Roadway segment LOS standards and thresholds provide the basis for analysis of arterial roadway segment performance. This analysis is based on the functional classification of the roadway, the maximum capacity, roadway geometrics, and the daily traffic volumes.

Table 2-2 summarizes the capacities for the various roadway classifications with the County of Imperial for each respective LOS.

**Table 2-2
LOS Criteria for Roadway Segments**

Facility Type	X-Section	LOS		
		C or Better	D	E
Expressway	154/210	< 60,000	< 70,000	< 80,000
Prime Arterial	106/136	< 44,600	< 50,000	< 57,000
Minor Arterial	82/102	< 29,600	< 33,400	< 37,000
Major Collector (Collector)	64/84	< 27,400	< 30,800	< 34,200
Minor Collector (Local Collector)	40/70	< 7,100	< 10,900	< 16,200
Local County (Residential)	40/60	< 1,500	*	*
Local County (Residential Cul-de-Sac or Loop Street)	40/60	< 200	*	*
Major Industrial Collector - (Industrial)	76/96	< 14,000	< 17,000	< 20,000
Industrial Local	44/64	< 7,000	< 8,500	< 10,000

Source: *Imperial County General Plan, Circulation and Scenic Highway Element, 2008*

* Levels of service are not applied to residential streets since their primary purpose is to serve abutting lots, not carry through traffic. Levels of service normally apply to roads carrying through traffic between major trip generators and attractors

2.4 Improvement Criteria

Senate Bill 743 (SB 743) was approved in 2013 and changes the way transportation impacts are measured under the California Environmental Quality Act (CEQA). Automobile delay resulting in a level of service (LOS) is no longer considered a significant impact under CEQA. However, the County of Imperial Department of Public Works requires transportation analyses to review roadway capacity in terms of LOS to identify deficiencies and require improvements to the circulation system outside of CEQA.

Based on the County General Plan, the LOS goal for intersections and roadway segments is to operate at LOS C or better. As a result, if an intersection or roadway segment degrades from LOS C or better to LOS D or worse with the addition of project traffic, improvements would be required.

3 EXISTING CONDITIONS

This section describes the existing roadway network, peak hour traffic volumes, and operations at the study area intersections and roadway segments.

3.1 Roadway Network

State Route 86 (SR-86) is a north-south divided roadway with 2 lanes of travel provided in each direction. According to the *County's Circulation and Scenic Highway Element*, SR-86 is classified as a State Highway/Expressway. It should be noted that Caltrans relinquished this roadway between Threshill Road and Ralph Road back to the City of Imperial. As a result, this roadway will be referenced as Imperial Avenue within City limits. Parking is prohibited on both sides of the roadway. The posted speed limit is 45 miles per hour (mph).

Figure 3-1 illustrates the intersection geometrics at the study area intersections.

Appendix A provides additional details on the Caltrans relinquishment of SR-86 to the City of Imperial.

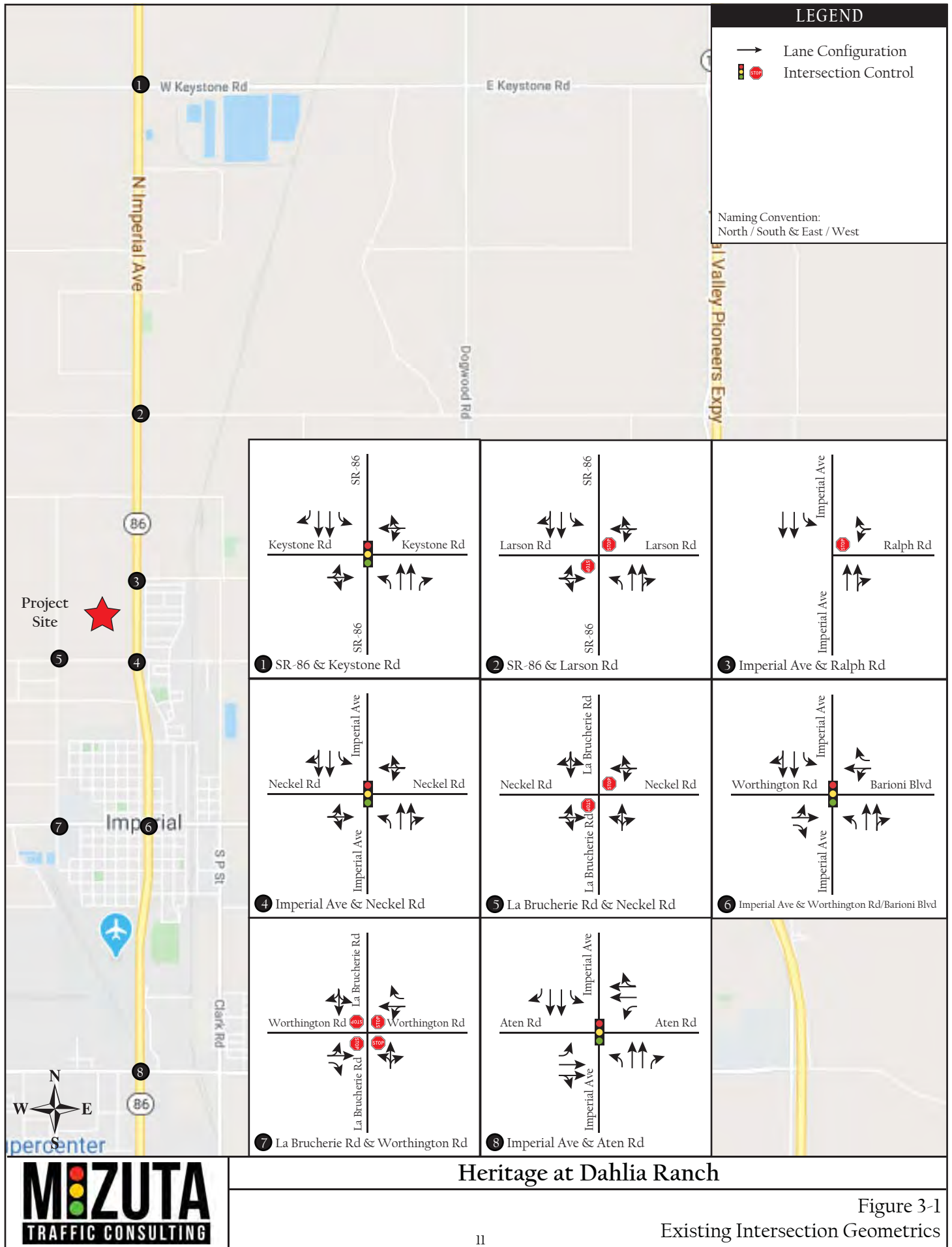

3.2 Traffic Volumes

Existing traffic volumes at the intersections and roadway segments in the study area were obtained on October 13, 2021. The intersection counts were collected for two hours during the AM peak period (from 7:00 AM to 9:00 AM) and during the PM peak period (from 4:00 PM to 6:00 PM). Figure 3-2 illustrates the traffic volumes at the study area intersections under Existing Conditions.

Appendix B contains a copy of the existing traffic volume data sheets.

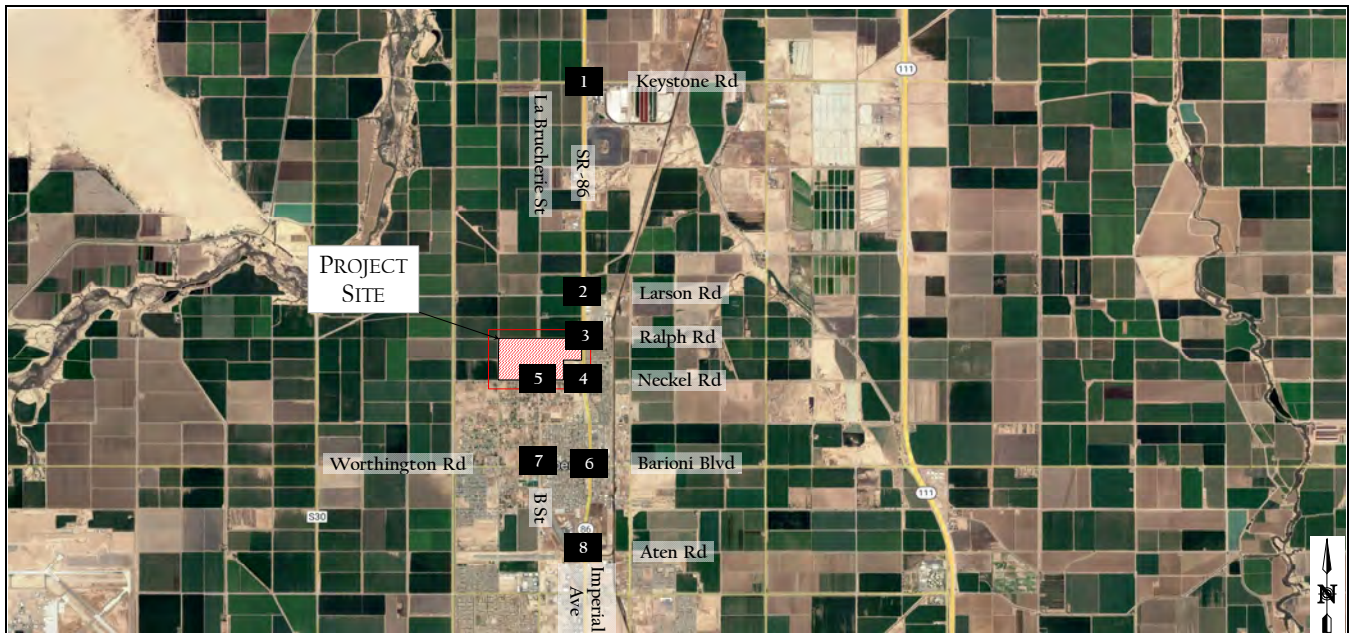

xx / yy - AM / PM Peak-Hour Turning Movement Volumes
 The naming convention for intersections is North / South & East / West

SR-86 & Keystone Rd		SR-86 & Larsen Rd		Imperial Ave & Ralph Rd		Imperial Ave & Neckel Rd	
↙ 36 / 33 ↘ 498 / 527 ↕ 44 / 51 ↗ 41 / 36 ↖ 23 / 26 ↘ 18 / 32	↙ 7 / 17 ↘ 503 / 562 ↕ 1 / 6 ↗ 5 / 5 ↖ 2 / 0 ↘ 1 / 7	↙ 486 / 527 ↘ 19 / 29 ↕ 22 / 10 ↗ 57 / 19	↙ 30 / 27 ↘ 497 / 482 ↕ 14 / 28 ↗ 54 / 45 ↖ 62 / 19 ↘ 138 / 80				
↙ 32 / 40 ↘ 32 / 12 ↕ 11 / 19 ↗ 18 / 10 ↖ 427 / 509 ↘ 48 / 25	↙ 19 / 6 ↘ 3 / 4 ↕ 2 / 0 ↗ 1 / 1 ↖ 492 / 546 ↘ 1 / 7	↙ 471 / 547 ↘ 40 / 29	↙ 33 / 12 ↘ 42 / 25 ↕ 12 / 4 ↗ 8 / 11 ↖ 430 / 540 ↘ 63 / 81				
La Brucherie Rd & Neckel Rd		Imperial Ave & Barioni Blvd / Worthington Rd		B St / La Brucherie Rd & Worthington Rd		Imperial Ave & Aten Rd	
↙ 1 / 7 ↘ 2 / 5 ↕ 1 / 0 ↗ 0 / 1 ↖ 43 / 43 ↘ 58 / 22	↙ 54 / 61 ↘ 613 / 577 ↕ 38 / 26 ↗ 75 / 50 ↖ 128 / 109 ↘ 53 / 53	↙ 62 / 23 ↘ 30 / 5 ↕ 103 / 36 ↗ 75 / 33 ↖ 293 / 209 ↘ 11 / 26	↙ 365 / 203 ↘ 652 / 523 ↕ 138 / 109 ↗ 137 / 119 ↖ 291 / 280 ↘ 127 / 173				
↙ 4 / 2 ↘ 40 / 37 ↕ 22 / 8 ↗ 7 / 5 ↖ 6 / 6 ↘ 41 / 10	↙ 68 / 47 ↘ 132 / 72 ↕ 206 / 102 ↗ 90 / 109 ↖ 452 / 648 ↘ 49 / 14	↙ 59 / 25 ↘ 379 / 182 ↕ 116 / 32 ↗ 0 / 1 ↖ 1 / 0	↙ 181 / 184 ↘ 328 / 268 ↕ 61 / 66 ↗ 59 / 76 ↖ 334 / 646 ↘ 65 / 145				

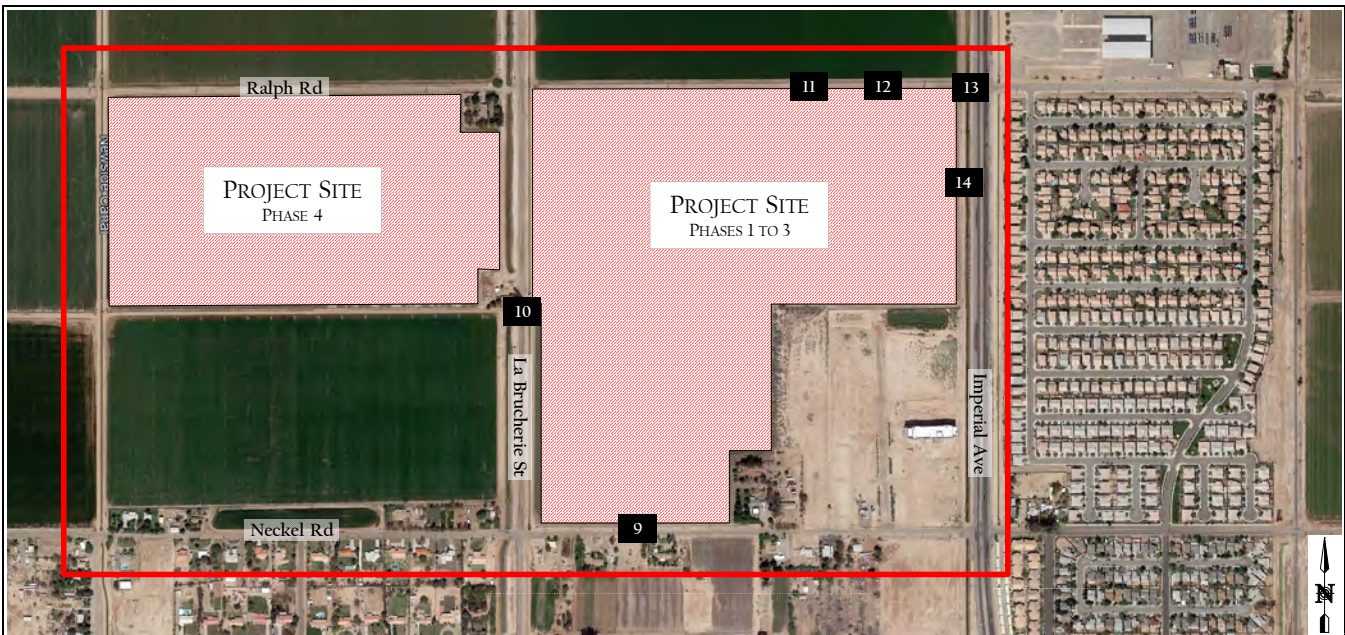

xx / yy - AM / PM Peak-Hour Turning Movement Volumes
 The naming convention for intersections is North / South & East / West

Proj Dwy & Neckel Rd	La Brucherie Rd & Proj Dwy	SFR Proj Dwy & Ralph Rd	Imperial Ave & Neckel Rd
Does not exist	Does not exist	Does not exist	Does not exist
Retail Proj Dwy & Ralph Rd	Imperial Ave & Proj Dwy		
Does not exist	Does not exist		

3.3 Intersection Analysis

Table 3-1 summarizes the LOS analysis results for the study area intersections under Existing Conditions.

**Table 3-1
Existing Peak Hour Intersection LOS Summary**

#	Intersection	Traffic Control	Peak Hour	Existing Conditions	
				Delay ¹	LOS ²
1	SR-86 & Keystone Rd	Signal	AM	9.3	A
			PM	9.2	A
2	SR-86 & Larson Rd	TWSC	AM	19.3	C
			PM	24.2	C
3	Imperial Ave & Ralph Rd	TWSC	AM	18.5	C
			PM	17.9	C
4	Imperial Ave & Neckel Rd	Signal	AM	17.9	B
			PM	14.5	B
5	La Brucherie Rd & Neckel Rd	TWSC	AM	10.2	B
			PM	9.6	A
6	Imperial Ave & Worthington Rd/Barioni Blvd	Signal	AM	26.7	C
			PM	20.9	C
7	La Brucherie Rd & Worthington Rd	AWSC	AM	24.2	C
			PM	10.4	B
8	Imperial Ave & Aten Rd	Signal	AM	29.2	C
			PM	24.0	C

Notes:

OWSC: One-Way Stopped Control, TWSC: Two-Way Stopped Control, AWSC: All-Way Stopped Control

1. Delays are reported as the average control delay for the entire intersection at signalized intersections and the worst movement at unsignalized intersections.

2. LOS calculations are based on the methodology outlined in the *Highway Capacity Manual 6th Edition (HCM6)* and performed using Synchro II.

As shown in the table, all intersections and project driveways operate at LOS C or better during the weekday peak-hours.

Appendix C contains the intersection LOS worksheets.

3.4 Roadway Segment Analysis

Table 3-2 summarizes the LOS analysis results for the study area roadway segments under Existing Conditions. It should be noted that SR-86/Imperial Avenue was assumed to function as a minor arterial since it is not built to its ultimate classification as an Expressway. As shown in the table, all roadway segments function at LOS B or better.

Table 3-2
Existing Roadway Segment LOS Summary

Roadway Segment	Functional Classification ¹	Capacity (LOS E)	ADT	v/c Ratio	LOS
SR-86					
North of Keystone Rd	Minor Arterial	37,000	14,881	0.40	B
Keystone Rd to Larsen Rd	Minor Arterial	37,000	14,205	0.38	A
Larsen Rd to Ralph Rd	Minor Arterial	37,000	13,649	0.37	A
Imperial Ave					
Ralph Rd to Neckel Rd	Minor Arterial	37,000	14,056	0.38	A
Neckel Rd to Worthington Rd	Minor Arterial	37,000	18,145	0.49	B
Worthington Rd to Aten Rd	Minor Arterial	37,000	19,986	0.54	B

Notes:

1. The roadway functional classification is based off the number of lanes that currently exist.

4 PROJECT TRAFFIC

This section describes the estimated trip generation, trip distribution, and assignment of trips to the adjacent roadway network.

4.1 Trip Generation

Trip generation rates for the project were developed utilizing a combination of rates published by the *Institute of Transportation Engineers (ITE) Trip Generation Manual, 10th Edition* were applied to the project's proposed uses to determine the traffic generation characteristics of the site. Upon reviewing various land uses contained in the *ITE Trip Generation Manual*, the following list contains the land uses that were selected to represent the project with the ITE land use code shown in parenthesis:

- Single-Family Detached Housing (210)
- Multifamily Housing (Low-Rise) (220)
- Medical-Dental Office Building (720)
- Shopping Center (820)
- Supermarket (850)
- Fast-Food Restaurant with Drive-Through Window (934)
- Gas Station with Convenience Market (945)

Table 4-1 summarizes the trip generation rates used for the various land uses of the project.

Table 4-1
Trip Generation Rates

Land Use	ITE Code	Weekday Daily	AM PEAK		PM PEAK	
			Rate	In:Out Ratio	Rate	In:Out Ratio
Single-Family Detached Housing	210	9.44 trips / du	0.74	0.25 : 0.75	0.99	0.63 : 0.37
Multifamily Housing (Low-Rise)	220	7.32 trips / du	0.46	0.23 : 0.77	0.56	0.63 : 0.37
Medical-Dental Office Building	720	34.80 trips / ksf	2.78	0.78 : 0.22	3.46	0.28 : 0.72
Shopping Center	820	37.75 trips / ksf	0.94	0.62 : 0.38	3.81	0.48 : 0.52
Supermarket	850	106.78 trips / ksf	3.82	0.60 : 0.40	9.24	0.51 : 0.49
Fast-Food Restaurant w/Drive-Thru Window	934	470.95 trips / ksf	40.19	0.51 : 0.49	32.67	0.52 : 0.48
Gas Station w/Convenience Mkt	945	1440.02 trips / ksf	75.99	0.51 : 0.49	88.38	0.51 : 0.49

Notes:

ksf: 1,000 square feet, du: dwelling units

The trip rates for the project's land uses are based on the *Institute of Transportation Engineers (ITE) Trip Generation Manual, 10th Edition* unless otherwise noted by a footnote.

Table 4-2 summarizes the trip generation, by phase, for the project. Trip credits such as passby trips were applied to the proposed uses based on standard ITE trip generation reduction factors. Passby trips are trips that are already on the road network and “passing by” the project site.

The *National Cooperative Highway Research Program (NCHRP) Report 684, Enhancing Internal Trip Capture Estimation for Mixed-Use Developments* was referenced to estimate the internal capture for the project. Internal trip capture rates for the retail, restaurant, medical, and residential land uses were used for the project. Internal trips would be generated between land uses within the development, but would not be added to the external street network. It should be noted that internal capture trips would only be applied during Phase 3. Appendix D contains the internal capture worksheets.

Table 4-2
Weekday Trip Generation Summary

Land Use	Amount	ADT	AM PEAK			PM PEAK			
			In	Out	Total	In	Out	Total	
PHASE 1									
Single-Family Detached Housing	133 du	1,256	25	74	99	84	48	132	
PHASE 2									
Single-Family Detached Housing	133 du	1,256	25	74	99	84	48	132	
PHASE 3									
Multifamily Housing (Low-Rise)	200 du	1,464	22	70	92	71	41	112	
Internal Capture Trips ²		-118	-4	-23	-27	-34	-22	-56	
Retail/Commercial	35.000 ksf	1,322	21	12	33	65	69	134	
Internal Capture Trips ²		-106	-11	-8	-19	-43	-39	-82	
Passby Reduction (34%) ¹		-414	-4	-1	-5	-8	-10	-18	
Medical/Commercial	33.120 ksf	1,153	73	20	93	33	82	115	
Internal Capture Trips ¹		-93	-15	-19	-34	-7	-9	-16	
Supermarket	20.000 ksf	2,136	47	30	77	95	90	185	
Passby Reduction (36%) ¹		-769	-17	-11	-28	-35	-33	-67	
Fast-Food Restaurant w/Drive-Through Window	4.800 ksf	2,261	99	94	193	82	75	157	
Internal Capture Trips ²		-181	-37	-17	-54	-33	-47	-80	
Passby Reduction (50%) ¹		-1,040	-31	-39	-70	-25	-14	-39	
Gas Station w/Convenience Market & Car Wash	3.200 ksf	4,609	125	119	244	145	138	283	
Passby Reduction (62%) ¹		-2,858	-78	-74	-152	-90	-86	-176	
Phase 3 Total Trip Generation		12,945	387	345	732	491	495	986	
Internal Capture Trips		-498	-67	-67	-134	-117	-117	-234	
Total Driveway Trips		12,447	320	278	598	374	378	752	
Passby Reduction		-5,081	-130	-125	-255	-158	-143	-300	
Phase 3 Net New Traffic		7,366	190	153	343	216	235	452	
PHASE 4									
Single-Family Detached Housing	202 du	1,907	38	112	150	126	74	200	
PHASE 1 Net Trip Generation		1,256	25	74	99	84	48	132	
PHASES 1 & 2 Net Trip Generation		2,512	50	148	198	168	96	264	
PHASES 1 TO 3 Net Trip Generation		9,878	240	301	541	384	331	716	
PHASES 1 TO 4 Net Trip Generation		11,785	278	413	691	510	405	916	

Notes:

1. The passby trip rate is based on the average rates published in the *ITE Trip Generation Handbook, 3rd Edition*.
2. The internal capture trips are estimated based on the methodologies contained in the *NCHRP Report 684*.

As shown in the table, the entire project is forecasted to generate a net total of 11,785 daily trips with 691 AM peak-hour trips and 916 PM peak-hour trips at the project driveways on the external street network.

4.2 Trip Distribution and Assignment

The Project trip distribution was estimated based on existing travel patterns, trip distributions from other approved projects in the study area, and on logical routes to regional facilities. The following list summarizes the proposed overall trip distribution for the residential land uses:

- 20 percent to/from the north via SR-86
- 40 percent to/from the south via Imperial Avenue
- 20 percent to/from the east
 - 10 percent via Barioni Boulevard
 - 10 percent via Aten Road
- 20 percent to/from the west
 - 10 percent via Worthington Road
 - 10 percent via Aten Road

The following list summarizes the proposed overall trip distribution for the retail land uses:

- 20 percent to/from the north via SR-86
- 20 percent to/from the south via Imperial Avenue
- 40 percent to/from the east
 - 10 percent via Ralph Road
 - 10 percent via Neckel Road
 - 10 percent via Barioni Boulevard
 - 10 percent via Aten Road
- 20 percent to/from the west
 - 10 percent via Worthington Road
 - 10 percent via Aten Road

The following list summarizes the figures along with the trip distribution in each phase of the project.

- **Figure 4-1:** Residential Uses in Phase 1
- **Figure 4-2:** Residential Uses in Phase 2
- **Figure 4-3:** Residential Uses in Phase 3
- **Figure 4-4:** Commercial/Retail Uses in Phase 3
- **Figure 4-5:** Residential Uses in Phase 4

It should be noted that in Phase 3, Ralph Road is constructed and extended to the east from Imperial Avenue. As a result, some of the Phase 1 and 2 trips were reassigned to use Ralph Road to access the project site.

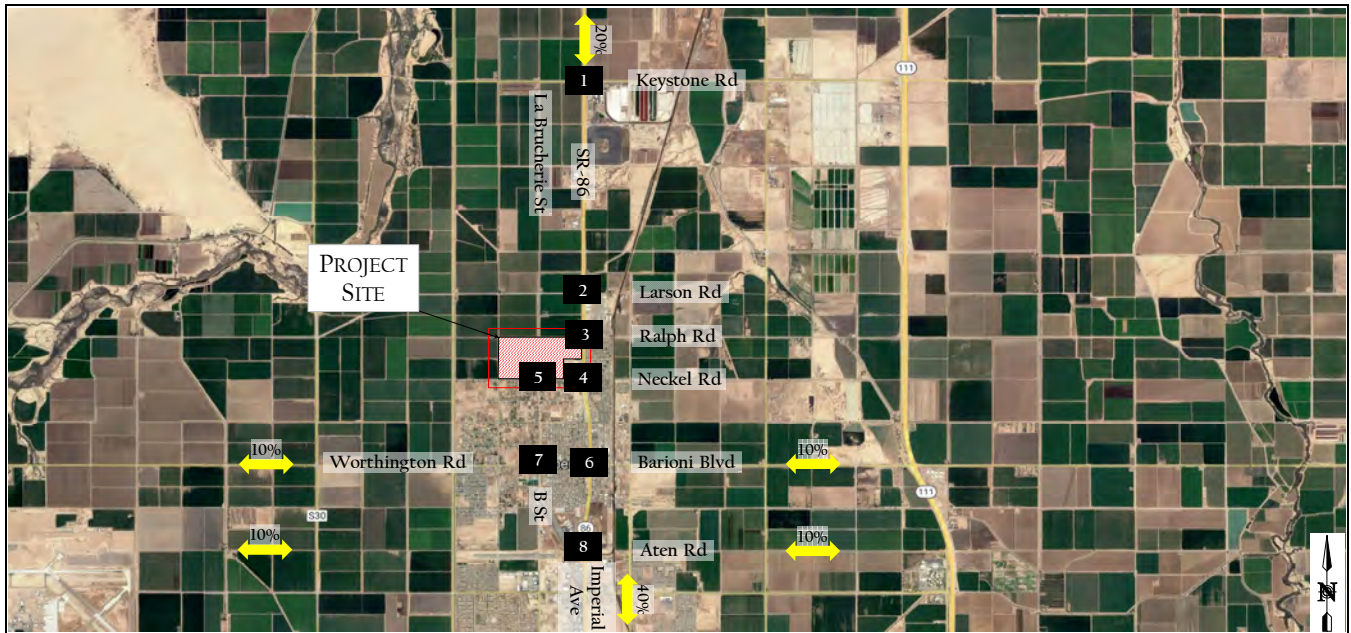

xx% / (yy%) - Enter % / (Exit %)
 The naming convention for intersections is North / South & East / West

xxx% Trip Distribution Percentage

SR-86 & Keystone Rd	SR-86 & Larsen Rd	Imperial Ave & Ralph Rd	Imperial Ave & Neckel Rd
La Brucherie Rd & Neckel Rd	Imperial Ave & Barioni Blvd / Worthington Rd		Imperial Ave & Aten Rd
		B St / La Brucherie Rd & Worthington Rd	



Heritage at Dahlia Ranch
 Phase 1 Project Trip Distribution

Figure 4-1

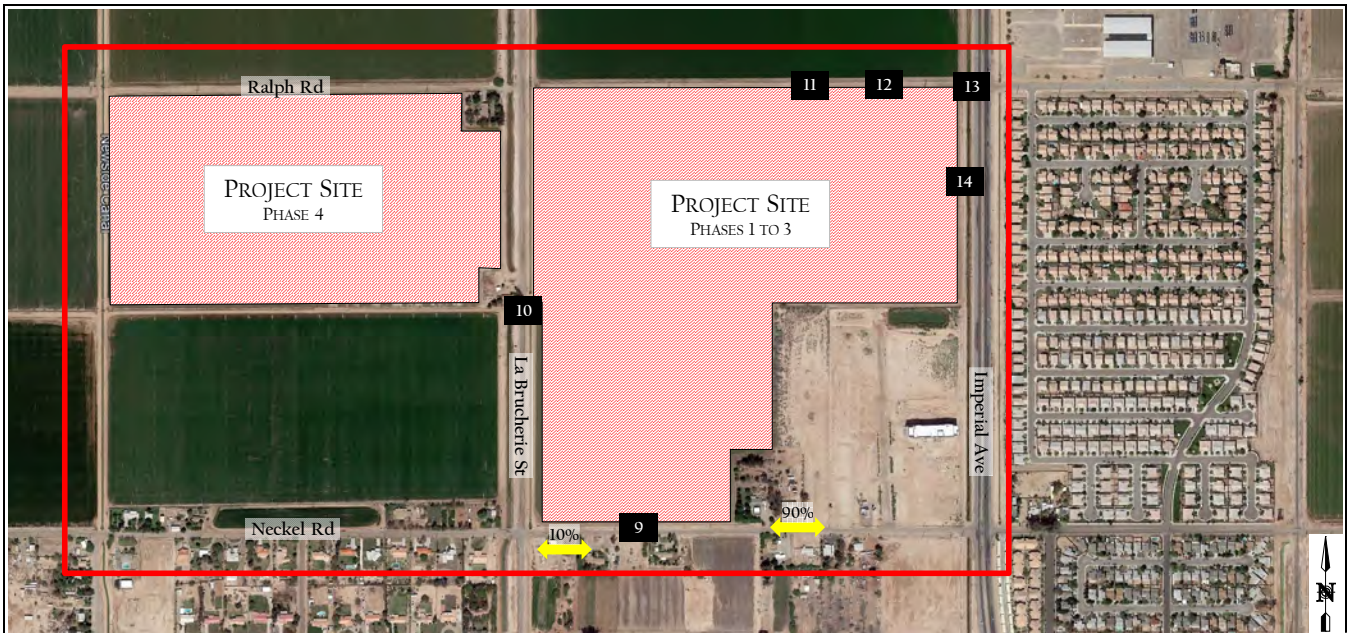

xx% / (yy%) - Enter % / (Exit %)

The naming convention for intersections is North / South & East / West

xx% Trip Distribution Percentage

Proj Dwy & Neckel Rd		La Brucherie Rd & Proj Dwy		SFR Proj Dwy & Ralph Rd		MFR Proj Dwy & Ralph Rd	
		Does not exist		Does not exist		Does not exist	
Retail Proj Dwy & Ralph Rd		Imperial Ave & Proj Dwy					
Does not exist		Does not exist					



Heritage at Dahlia Ranch
Phase 1 Project Trip Distribution

Figure 4-1a

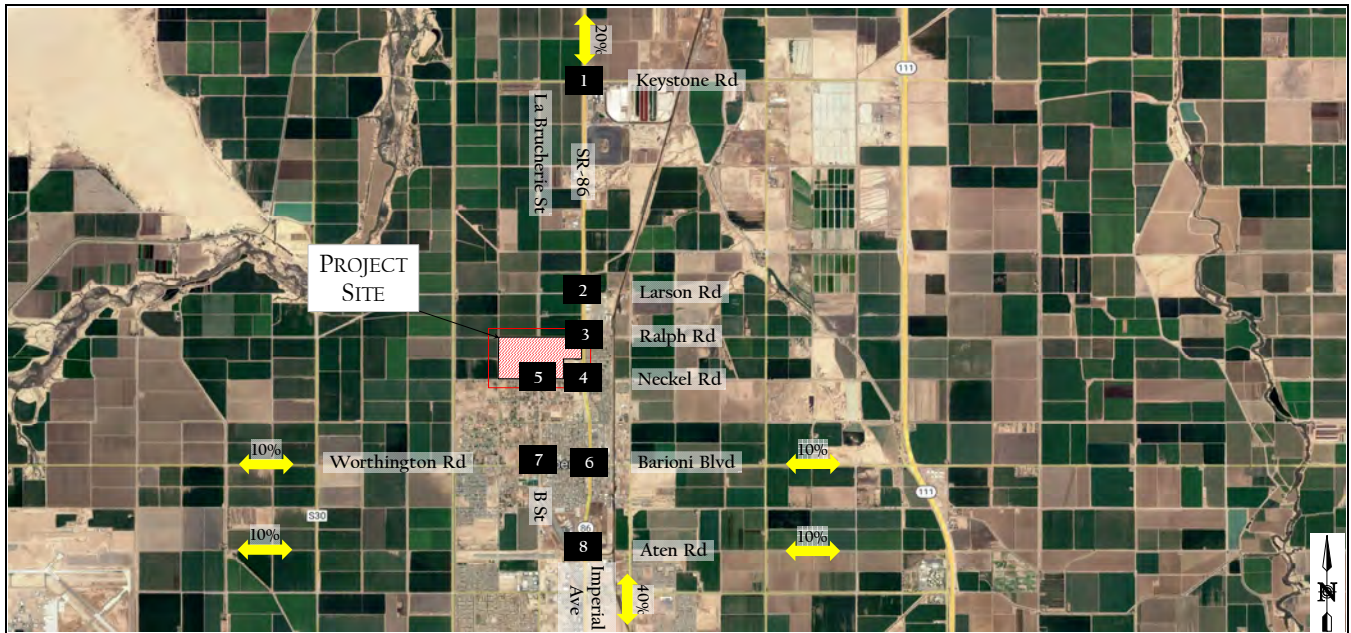

xx% / (yy%) - Enter % / (Exit %)
 The naming convention for intersections is North / South & East / West

xxx% Trip Distribution Percentage

SR-86 & Keystone Rd	SR-86 & Larsen Rd	Imperial Ave & Ralph Rd	Imperial Ave & Neckel Rd
La Brucherie Rd & Neckel Rd	Imperial Ave & Barioni Blvd / Worthington Rd		Imperial Ave & Aten Rd

	<p>Heritage at Dahlia Ranch Phase 2 Project Trip Distribution</p>	<p>Figure 4-2</p>
--	--	-------------------

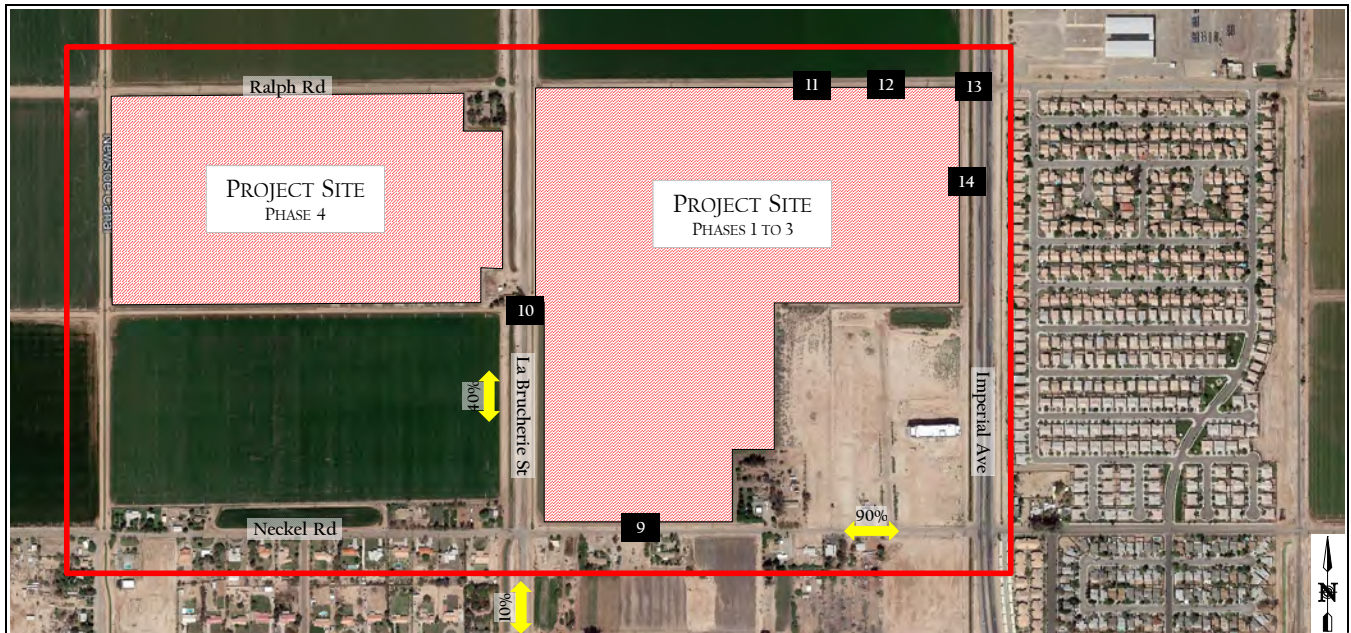

xx% / (yy%) - Enter % / (Exit %)
 The naming convention for intersections is North / South & East / West

Proj Dwy & Neckel Rd	La Brucherie Rd & Proj Dwy	SFR Proj Dwy & Ralph Rd	MFR Proj Dwy & Ralph Rd
		Does not exist	Does not exist
Retail Proj Dwy & Ralph Rd	Imperial Ave & Proj Dwy		
Does not exist	Does not exist		



Heritage at Dahlia Ranch
 Phase 2 Project Trip Distribution

Figure 4-2a

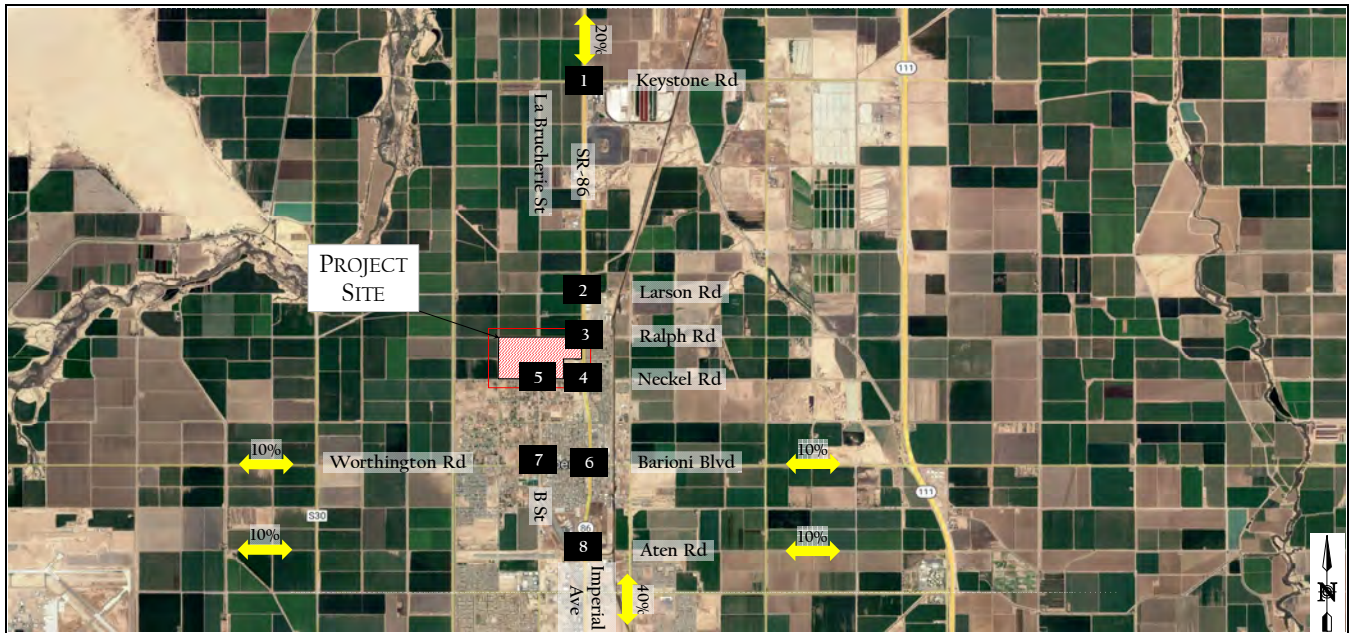

xx% / (yy%) - Enter % / (Exit %)
 The naming convention for intersections is North / South & East / West
 Trip Distribution Percentage

SR-86 & Keystone Rd	SR-86 & Larsen Rd	Imperial Ave & Ralph Rd	Imperial Ave & Neckel Rd
20% / (0%) ↓ 1 ↑ 0% / (20%)	20% / (0%) ↓ 2 ↑ 0% / (20%)	20% / (0%) ↙ 3 ↘ 0% / (20%) ↙ 0% / (70%) ↘ 70% / (0%)	0% / (70%) ↓ 4 ↑ 70% / (0%)
La Brucherie Rd & Neckel Rd	Imperial Ave & Barioni Blvd / Worthington Rd	B St / La Brucherie Rd & Worthington Rd	Imperial Ave & Aten Rd
0% / (10%) ↓ 5 ↑ 10% / (0%)	0% / (60%) ↓ 6 ↙ 10% / (0%) ↘ 0% / (10%) ↑ 60% / (0%)	0% / (10%) ↙ 7 ↘ 10% / (0%)	0% / (10%) ↙ 8 ↘ 0% / (40%) ↙ 0% / (10%) ↘ 10% / (0%) ↑ 40% / (0%)

	<p>Heritage at Dahlia Ranch</p> <p>Phase 3 (Multi-Family) Project Trip Distribution</p>	<p>Figure 4-3</p>
--	---	-------------------

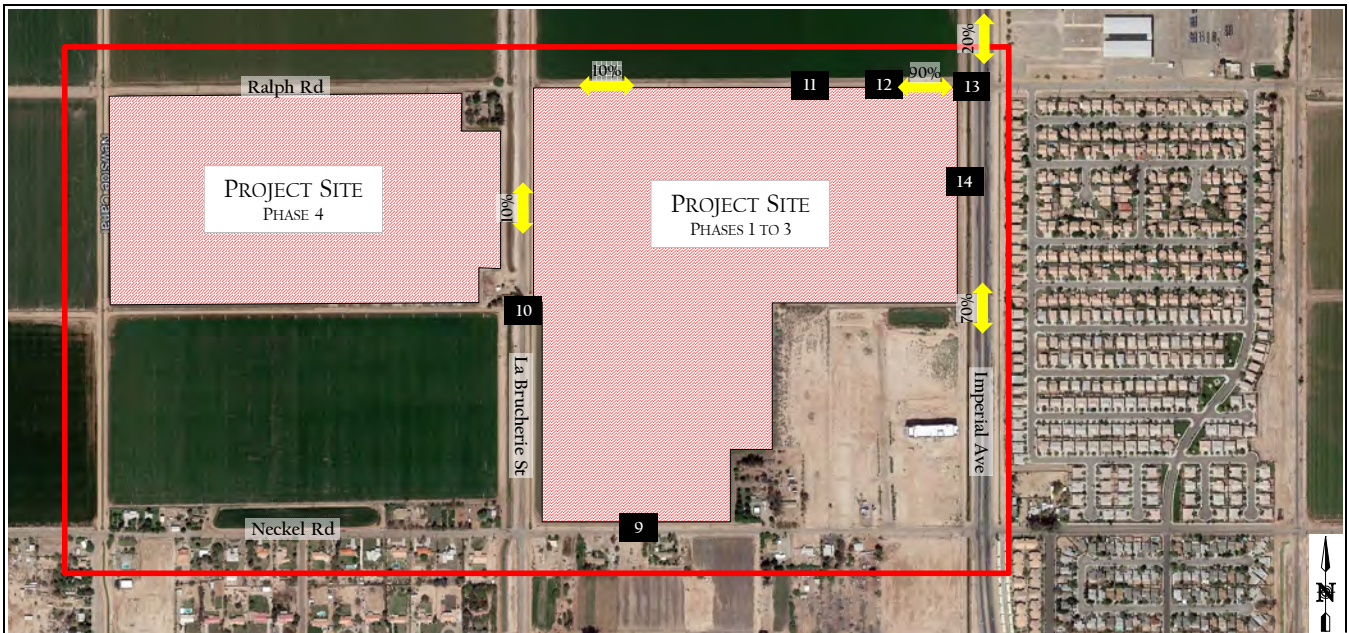

xx% / (yy%) - Enter % / (Exit %)

The naming convention for intersections is North / South & East / West

xxx% Trip Distribution Percentage

Proj Dwy & Neckel Rd	La Brucherie Rd & Proj Dwy	SFR Proj Dwy & Ralph Rd	MFR Proj Dwy & Ralph Rd
Retail Proj Dwy & Ralph Rd	Imperial Ave & Proj Dwy		



Heritage at Dahlia Ranch
Phase 3 (Multi-Family) Project Trip Distribution

Figure 4-3a

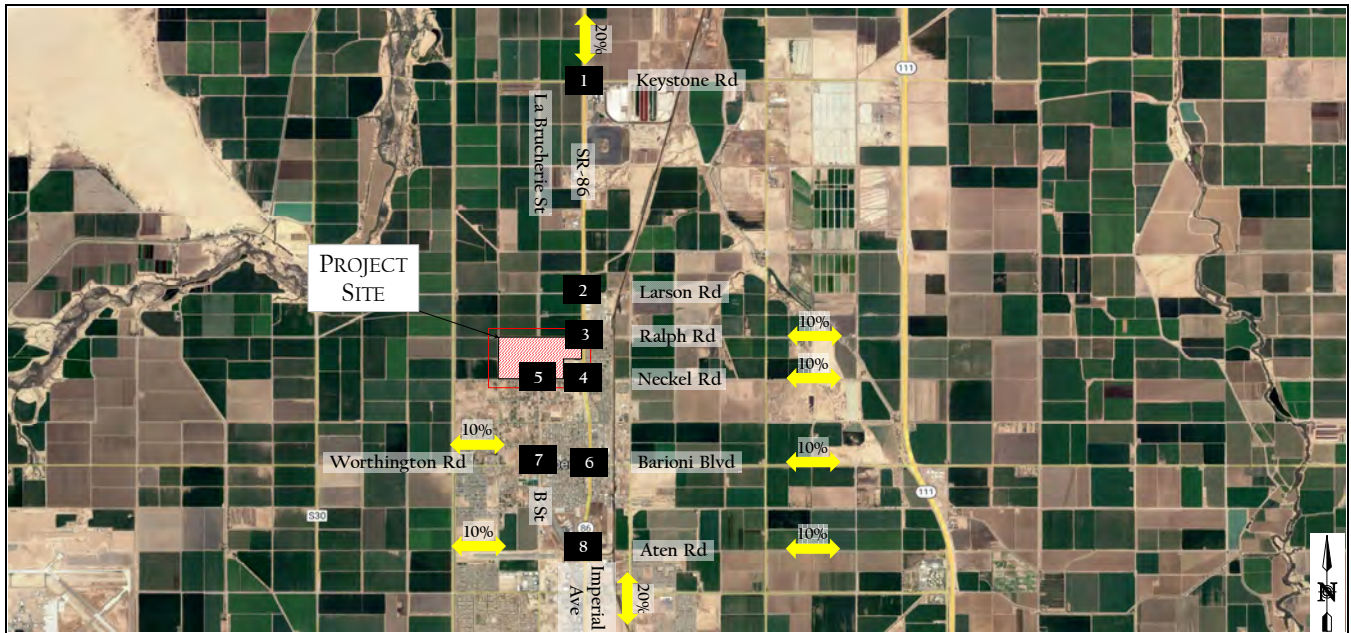

xx% / (yy%) - Enter % / (Exit %)
 The naming convention for intersections is North / South & East / West

xxx% Trip Distribution Percentage

SR-86 & Keystone Rd	SR-86 & Larsen Rd	Imperial Ave & Ralph Rd	Imperial Ave & Neckel Rd
La Brucherie Rd & Neckel Rd	Imperial Ave & Barioni Blvd / Worthington Rd	B St / La Brucherie Rd & Worthington Rd	Imperial Ave & Aten Rd

	<p>Heritage at Dahlia Ranch Phase 3 (Commercial/Retail) Project Trip Distribution</p>	<p>Figure 4-4</p>
--	--	-------------------

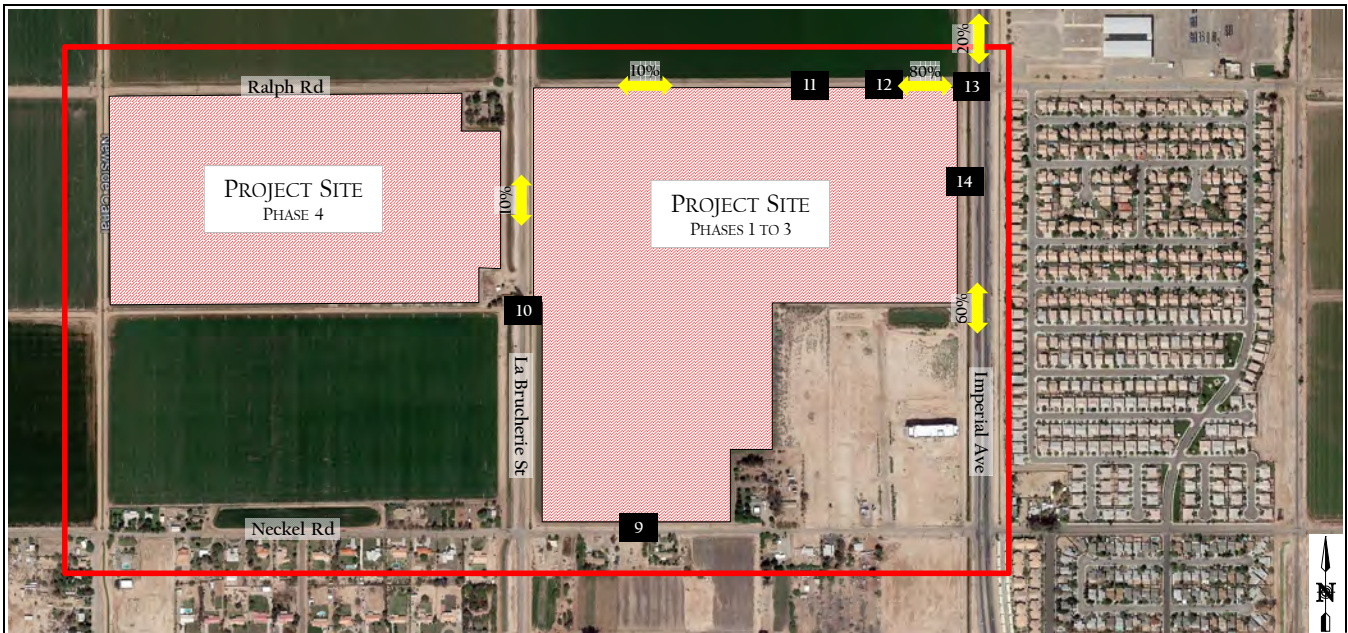

xx% / (yy%) - Enter % / (Exit %)
 The naming convention for intersections is North / South & East / West

Proj Dwy & Neckel Rd	La Brucherie Rd & Proj Dwy	SFR Proj Dwy & Ralph Rd	MFR Proj Dwy & Ralph Rd
Retail Proj Dwy & Ralph Rd	Imperial Ave & Proj Dwy		



Heritage at Dahlia Ranch
 Phase 3 (Commercial/Retail) Project Trip Distribution

Figure 4-4a

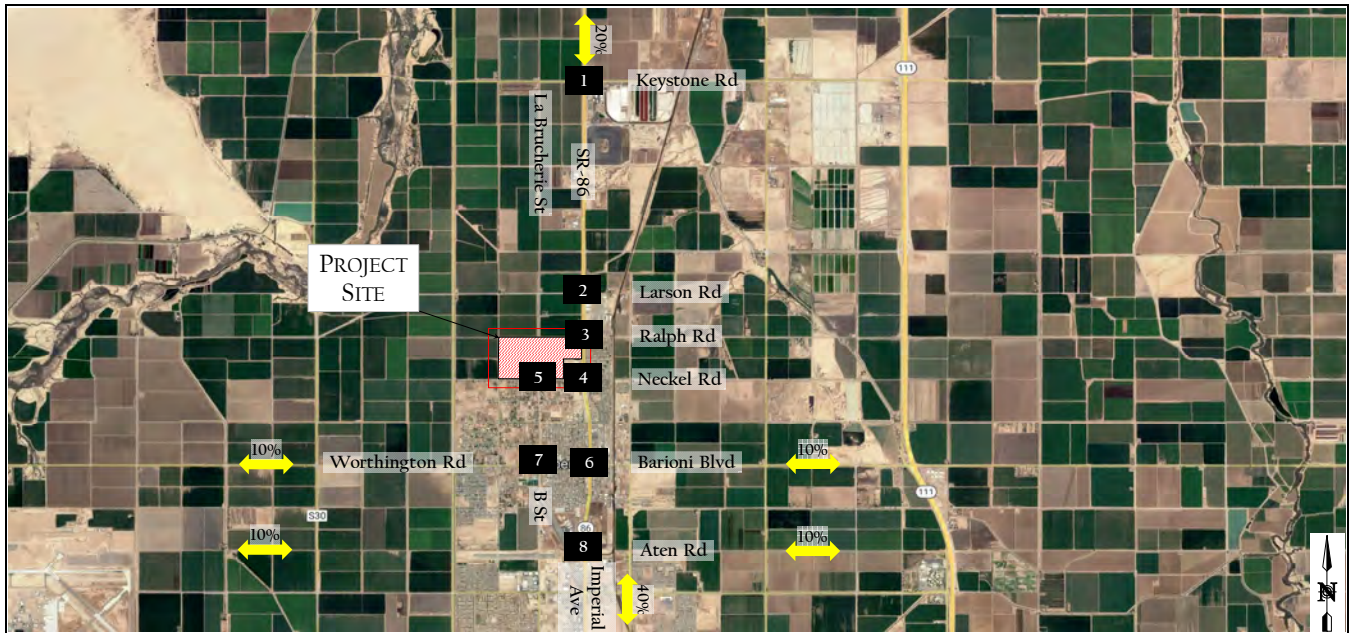

xx% / (yy%) - Enter % / (Exit %)
 The naming convention for intersections is North / South & East / West
 Trip Distribution Percentage

SR-86 & Keystone Rd	SR-86 & Larsen Rd	Imperial Ave & Ralph Rd	Imperial Ave & Neckel Rd
La Brucherie Rd & Neckel Rd	Imperial Ave & Barioni Blvd / Worthington Rd		Imperial Ave & Aten Rd
		B St / La Brucherie Rd & Worthington Rd	

	<p>Heritage at Dahlia Ranch Phase 4 Project Trip Distribution</p>	<p>Figure 4-5</p>
--	--	-------------------

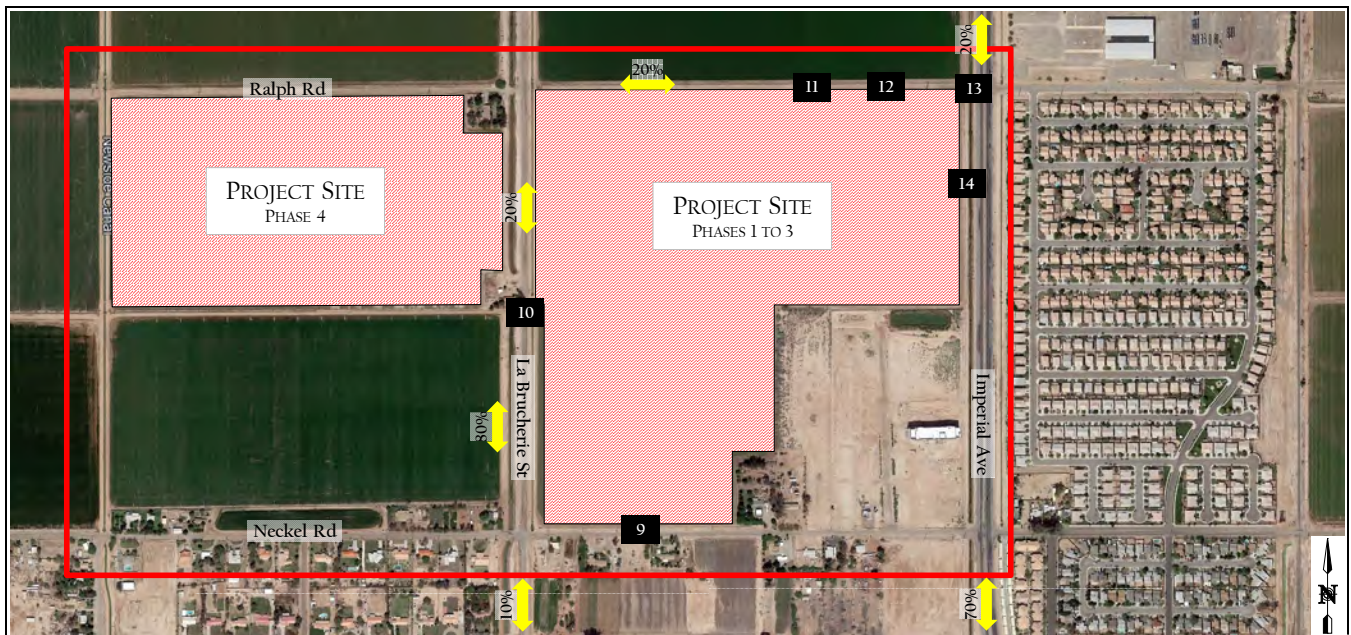

xx% / (yy%) - Enter % / (Exit %)
 The naming convention for intersections is North / South & East / West

xx% Trip Distribution Percentage

Proj Dwy & Neckel Rd	La Brucherie Rd & Proj Dwy	SFR Proj Dwy & Ralph Rd	MFR Proj Dwy & Ralph Rd
<p>← 70% / (0%)</p> <p>9</p> <p>0% / (70%) →</p>	<p>20% / (0%)</p> <p>10</p> <p>0% / (20%) ↘</p> <p>0% / (80%) ↙</p> <p>80% / (0%)</p>	<p>← 20% / (0%)</p> <p>11</p> <p>0% / (20%) →</p>	<p>← 20% / (0%)</p> <p>12</p> <p>0% / (20%) →</p>
Retail Proj Dwy & Ralph Rd	Imperial Ave & Proj Dwy		
<p>← 20% / (0%)</p> <p>13</p> <p>0% / (20%) →</p>	<p>14</p>		



Heritage at Dahlia Ranch
 Phase 4 Project Trip Distribution

Figure 4-5a

4.3 Project Trip Assignment

Based on the project trip generation and distribution, the project trips were assigned to the intersections and project driveways in the study area for the various project phases. The following list summarizes the figures along with the trip assignment in each phase of the project:

- Figure 4-6: Residential Uses in Phase 1
- Figure 4-7: Residential Uses in Phase 2
- Figure 4-8: Residential Uses in Phase 3
- Figure 4-9: Commercial/Retail Uses in Phase 3
- Figure 4-10: Residential Uses in Phase 4

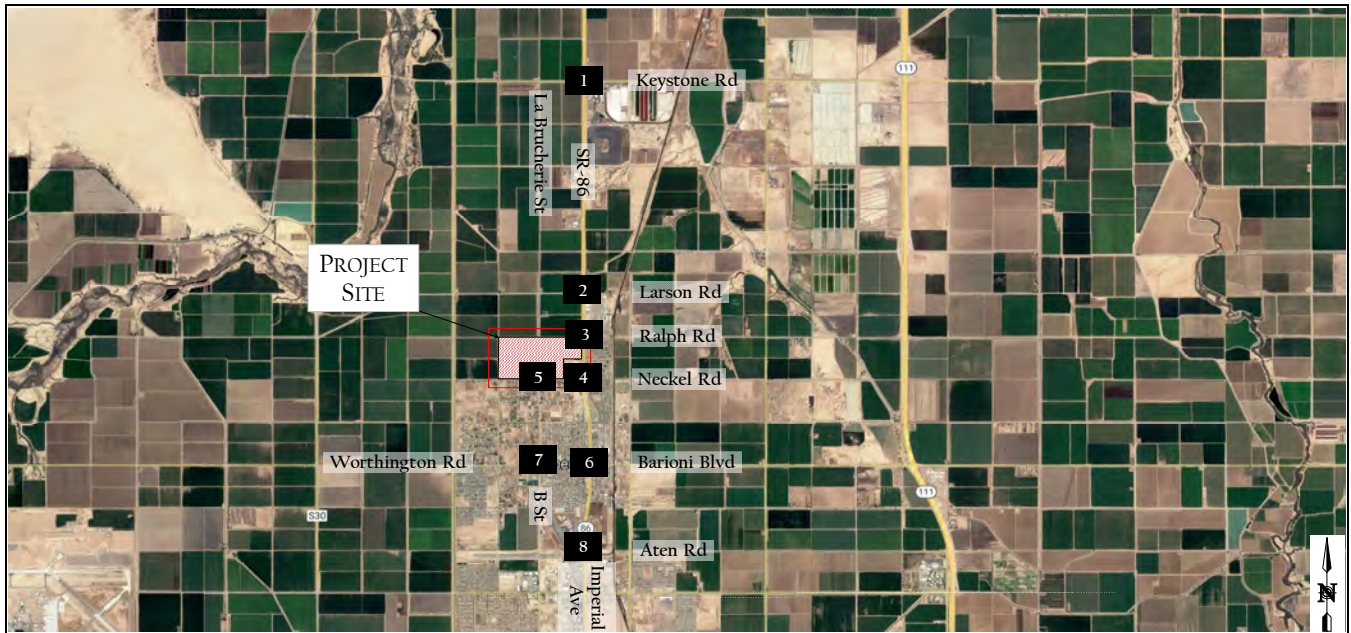

xx / yy - AM / PM Peak-Hour Turning Movement Volumes
 The naming convention for intersections is North / South & East / West

SR-86 & Keystone Rd		SR-86 & Larsen Rd		Imperial Ave & Ralph Rd		Imperial Ave & Neckel Rd	
	1		2		3		4
La Brucherie Rd & Neckel Rd		Imperial Ave & Barioni Blvd / Worthington Rd		B St / La Brucherie Rd & Worthington Rd		Imperial Ave & Aten Rd	
	5		6		7		8

	<p>Heritage at Dahlia Ranch Phase I Project Trip Assignment</p>	<p>Figure 4-6</p>
--	--	-------------------

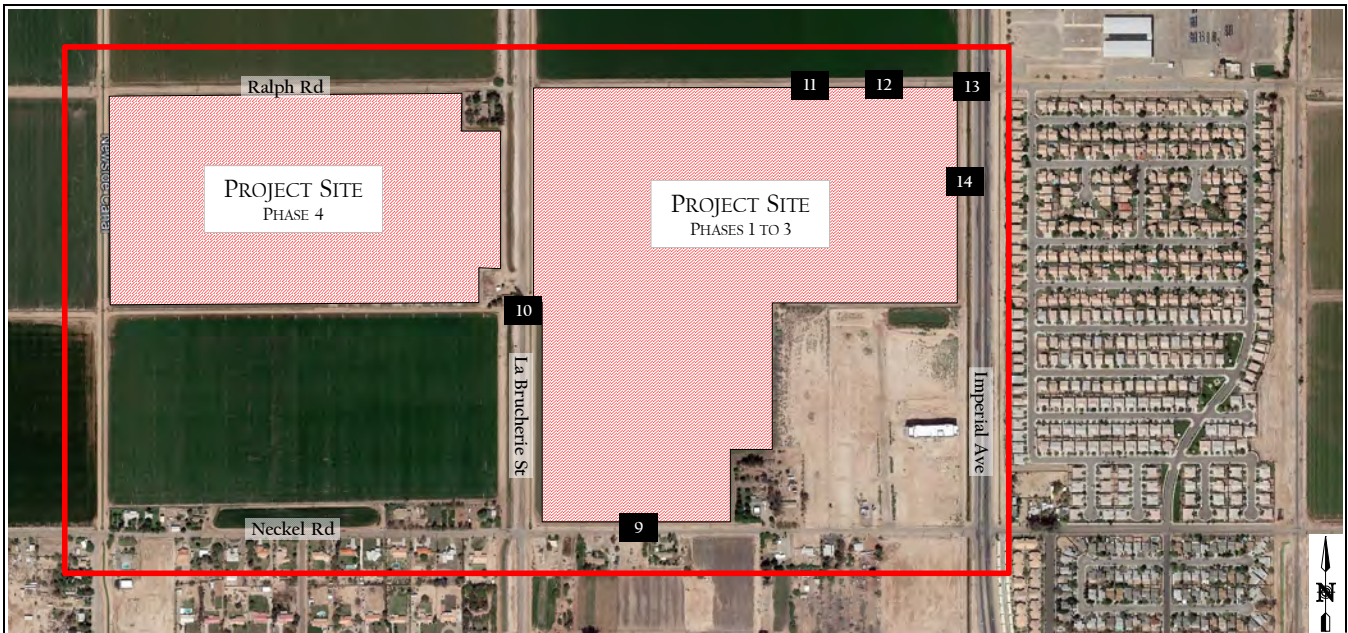

xx / yy - AM / PM Peak-Hour Turning Movement Volumes
 The naming convention for intersections is North / South & East / West

Proj Dwy & Neckel Rd	La Brucherie Rd & Proj Dwy	SFR Proj Dwy & Ralph Rd	MFR Proj Dwy & Ralph Rd
	Does not exist	Does not exist	Does not exist
Retail Proj Dwy & Ralph Rd	Imperial Ave & Proj Dwy		
Does not exist	Does not exist		



Heritage at Dahlia Ranch
 Phase 1 Project Trip Assignment

Figure 4-6a

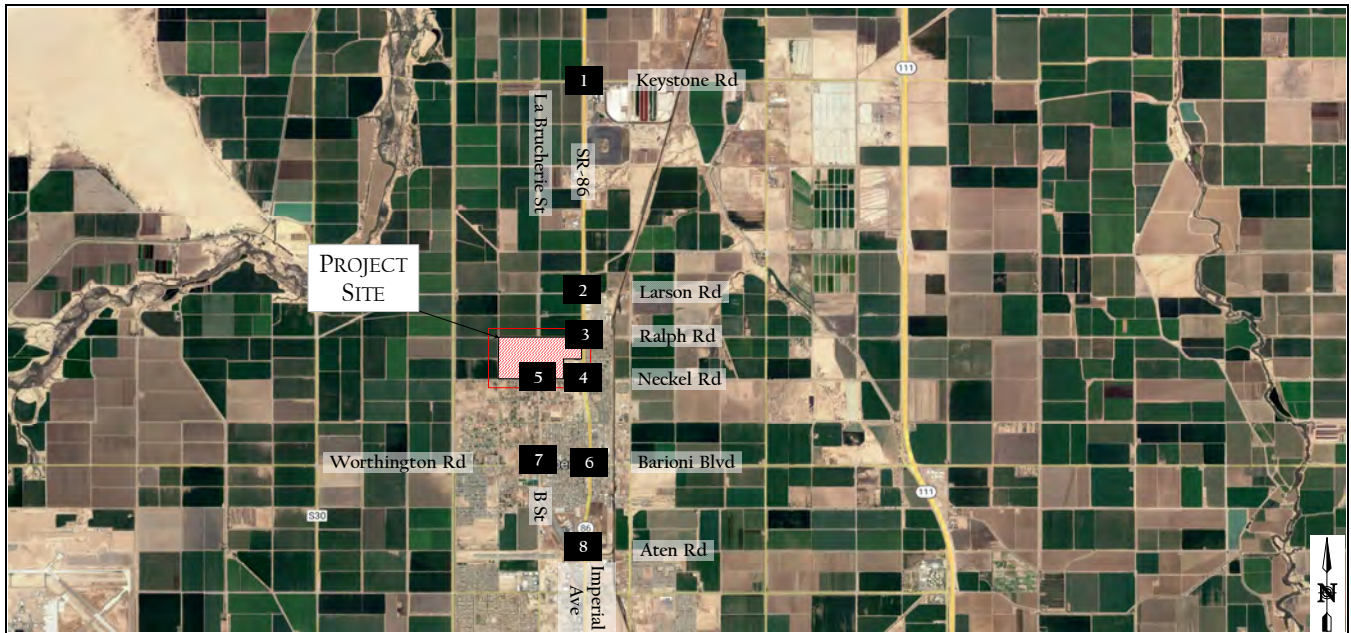

xx / yy - AM / PM Peak-Hour Turning Movement Volumes
 The naming convention for intersections is North / South & East / West

SR-86 & Keystone Rd		SR-86 & Larsen Rd		Imperial Ave & Ralph Rd		Imperial Ave & Neckel Rd	
	1		2		3		4
La Brucherie Rd & Neckel Rd		Imperial Ave & Barioni Blvd / Worthington Rd		B St / La Brucherie Rd & Worthington Rd		Imperial Ave & Aten Rd	
	5		6		7		8

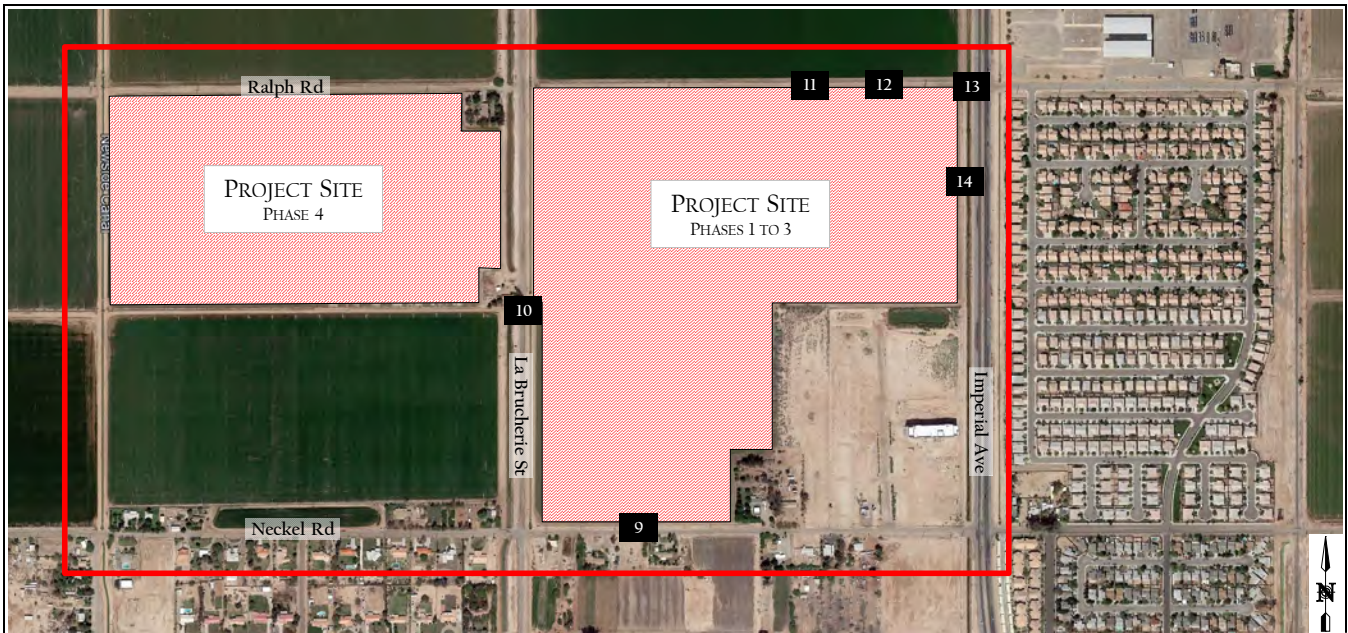

xx / yy - AM / PM Peak-Hour Turning Movement Volumes
 The naming convention for intersections is North / South & East / West

Proj Dwy & Neckel Rd		La Brucherie Rd & Proj Dwy		SFR Proj Dwy & Ralph Rd		MFR Proj Dwy & Ralph Rd	
				Does not exist		Does not exist	
Retail Proj Dwy & Ralph Rd		Imperial Ave & Proj Dwy					
Does not exist		Does not exist					



Heritage at Dahlia Ranch
 Phase 2 Project Trip Assignment

Figure 4-7a

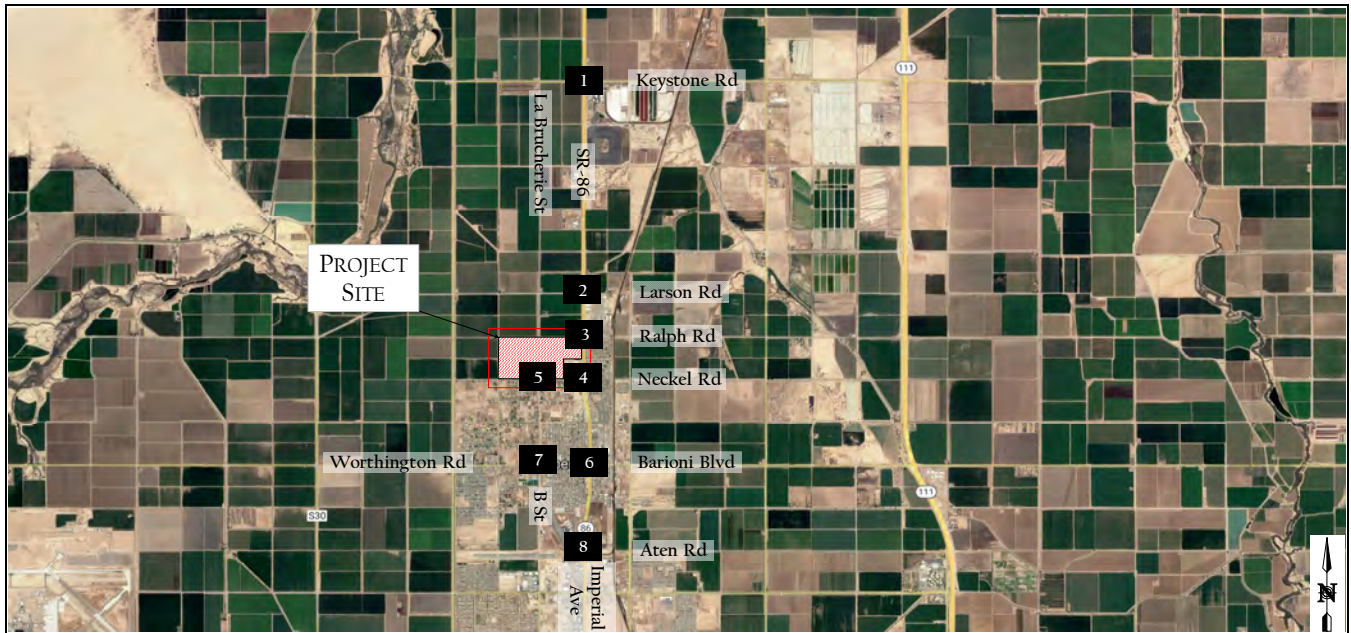

xx / yy - AM / PM Peak-Hour Turning Movement Volumes
 The naming convention for intersections is North / South & East / West

SR-86 & Keystone Rd		SR-86 & Larsen Rd		Imperial Ave & Ralph Rd		Imperial Ave & Neckel Rd	
↕ 4 / 7	1	↕ 4 / 7	2	↙ 4 / 7 ↘ 9 / 4 ↖ 33 / 13 ↗ 13 / 26	3	↕ 33 / 13	4
↔ 9 / 4		↔ 9 / 4				↔ 13 / 26	
La Brucherie Rd & Neckel Rd		Imperial Ave & Barioni Blvd / Worthington Rd		B St / La Brucherie Rd & Worthington Rd		Imperial Ave & Aten Rd	
↕ 5 / 2	5	↕ 28 / 11 ↙ 5 / 2 ↘ 2 / 4	6	↙ 5 / 2 ↘ 2 / 4	7	↙ 5 / 2 ↘ 19 / 8 ↖ 5 / 2 ↗ 2 / 4	8
↔ 2 / 4		↔ 11 / 22		↔ 2 / 4		↔ 7 / 15	

	Heritage at Dahlia Ranch Phase 3 (Multi-Family) Project Trip Assignment	Figure 4-8
--	--	------------

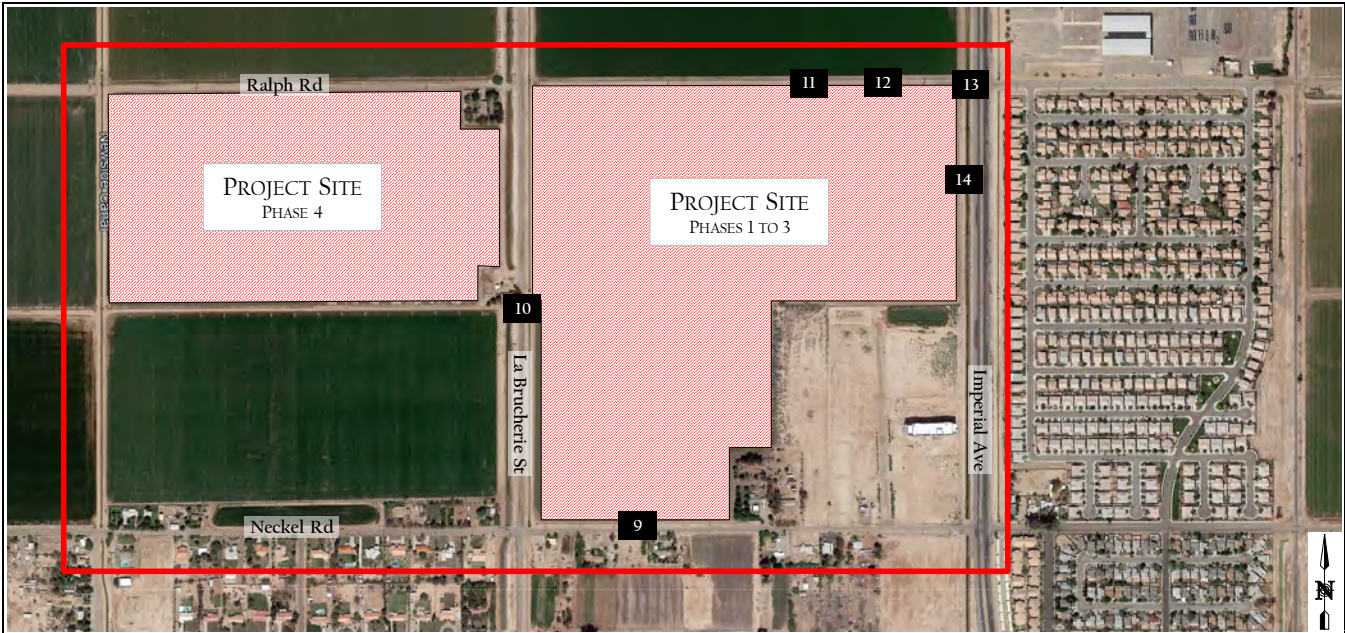

xx / yy - AM / PM Peak-Hour Turning Movement Volumes
 The naming convention for intersections is North / South & East / West

Proj Dwy & Neckel Rd	La Brucherie Rd & Proj Dwy	SFR Proj Dwy & Ralph Rd	MFR Proj Dwy & Ralph Rd
Retail Proj Dwy & Ralph Rd	Imperial Ave & Proj Dwy		



Heritage at Dahlia Ranch
 Phase 3 (Multi-Family) Project Trip Assignment

Figure 4-8a

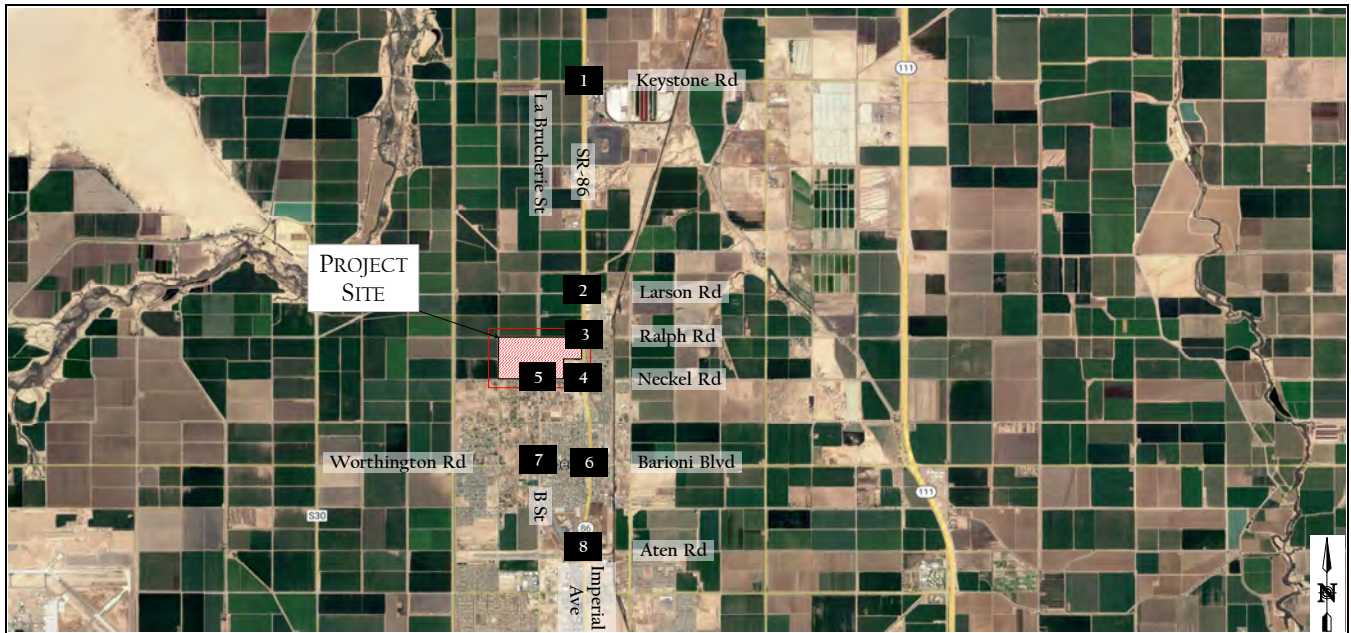

xx / yy - AM / PM Peak-Hour Turning Movement Volumes
 The naming convention for intersections is North / South & East / West

SR-86 & Keystone Rd		SR-86 & Larsen Rd		Imperial Ave & Ralph Rd		Imperial Ave & Neckel Rd	
	1		2		3		4
La Brucherie Rd & Neckel Rd		Imperial Ave & Barioni Blvd / Worthington Rd		B St / La Brucherie Rd & Worthington Rd		Imperial Ave & Aten Rd	
	5		6		7		8

	<p>Heritage at Dahlia Ranch Phase 3 (Commercial/Retail) Project Trip Assignment</p>	<p>Figure 4-9</p>
--	--	-------------------

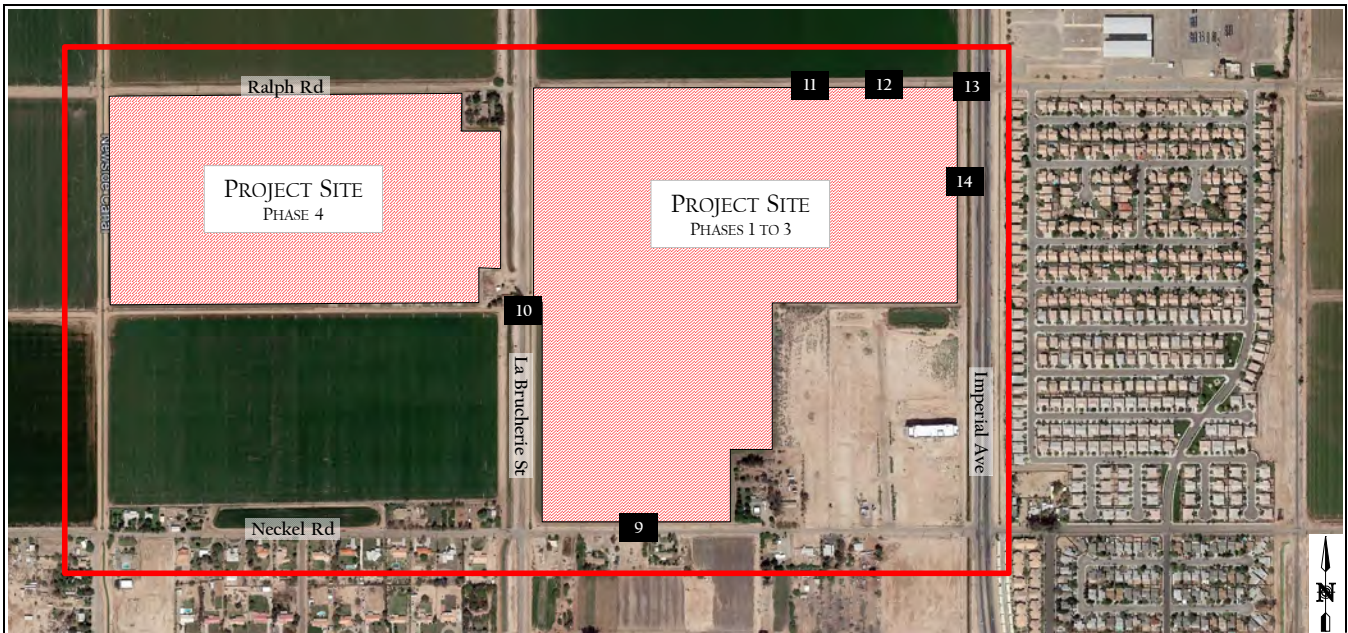

xx / yy - AM / PM Peak-Hour Turning Movement Volumes
 The naming convention for intersections is North / South & East / West

Proj Dwy & Neckel Rd	La Brucherie Rd & Proj Dwy	SFR Proj Dwy & Ralph Rd	MFR Proj Dwy & Ralph Rd
Retail Proj Dwy & Ralph Rd	Imperial Ave & Proj Dwy		



Heritage at Dahlia Ranch
 Phase 3 (Commercial/Retail) Project Trip Assignment

Figure 4-9a

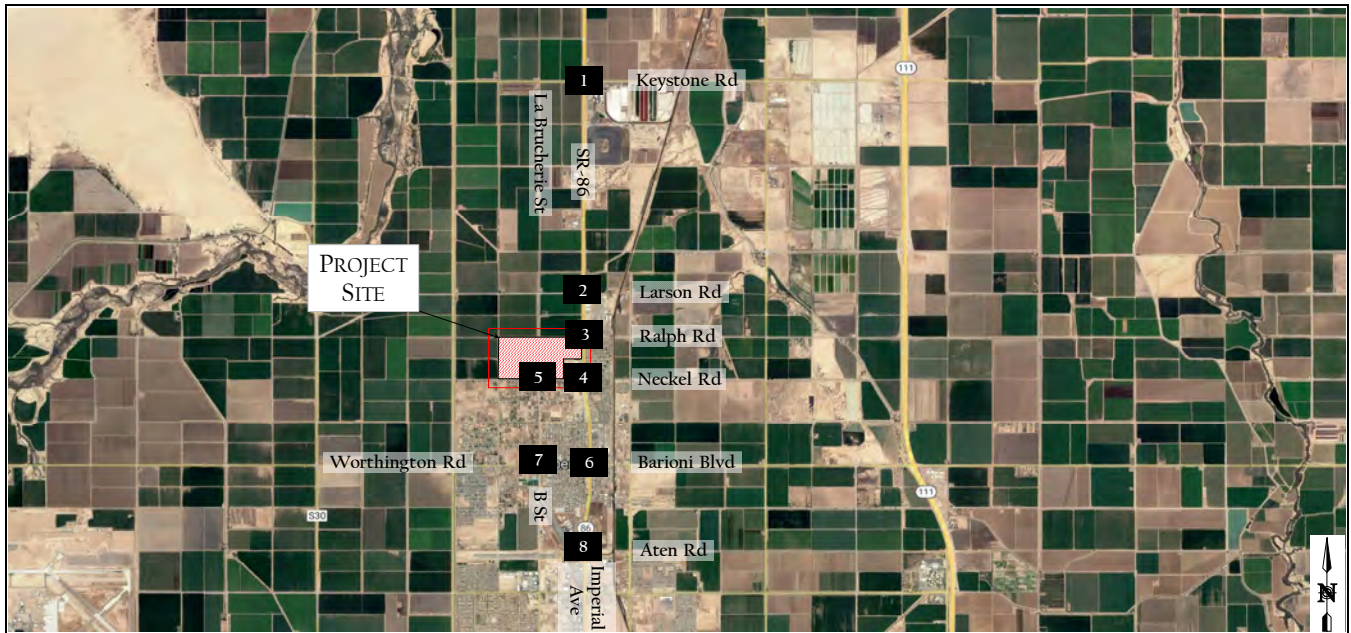

xx / yy - AM / PM Peak-Hour Turning Movement Volumes
 The naming convention for intersections is North / South & East / West

SR-86 & Keystone Rd		SR-86 & Larsen Rd		Imperial Ave & Ralph Rd		Imperial Ave & Neckel Rd	
8 / 25 ↓	1	22 / 15 ↑		8 / 25 ↙	3	78 / 52 ↙	27 / 88 ↘
		8 / 25 ↓	2	22 / 15 ↑			
				22 / 15 ↘	4		
La Brucherie Rd & Neckel Rd		Imperial Ave & Barioni Blvd / Worthington Rd		B St / La Brucherie Rd & Worthington Rd		Imperial Ave & Aten Rd	
11 / 7 ↓	5	67 / 44 ↙	6	11 / 7 ↙	7	11 / 7 ↙	4 / 13 ↙
78 / 52 ↘	4 / 13 ↑	11 / 7 ↘	23 / 76 ↑	4 / 13 ↘		45 / 30 ↓	15 / 50 ↑
		4 / 13 ↘			8	11 / 7 ↘	

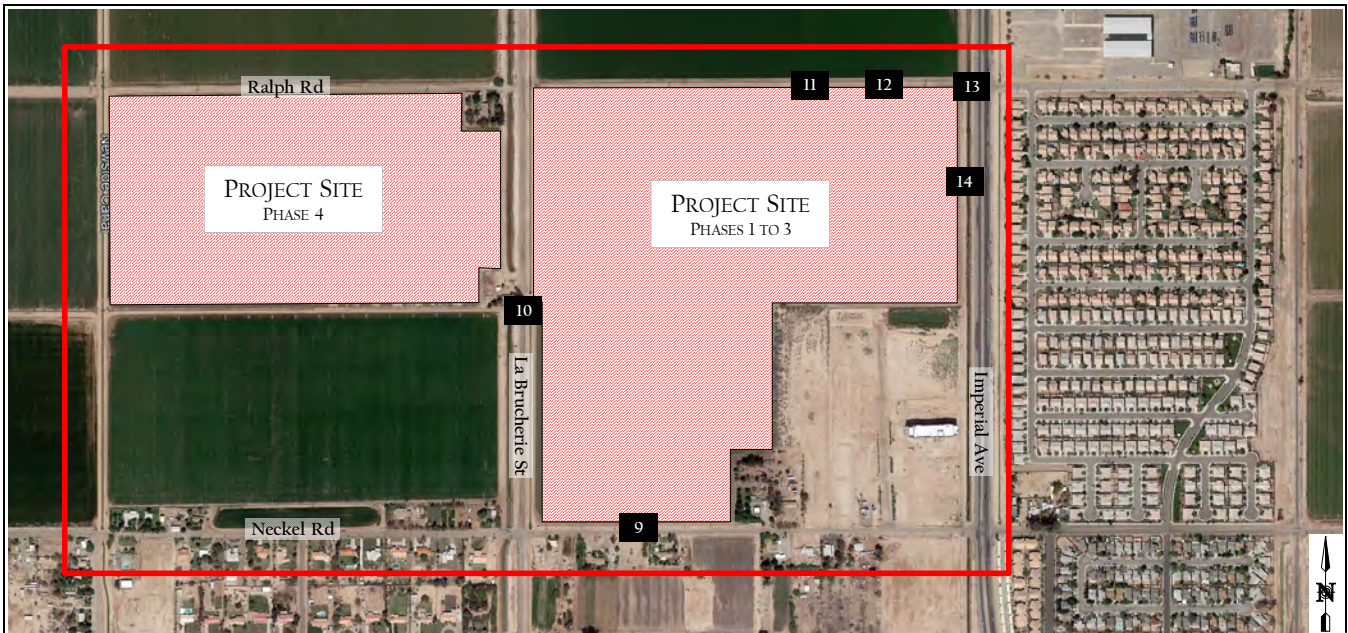

xx / yy - AM / PM Peak-Hour Turning Movement Volumes
 The naming convention for intersections is North / South & East / West

Proj Dwy & Neckel Rd	La Brucherie Rd & Proj Dwy	SFR Proj Dwy & Ralph Rd	MFR Proj Dwy & Ralph Rd
<p>← 27 / 88</p> <p>9</p> <p>78 / 52 →</p>	<p>8 / 25</p> <p>22 / 15 ↘</p> <p>90 / 59 ↙</p> <p>10</p> <p>101 / 101</p> <p>30 / 30</p>	<p>← 8 / 25</p> <p>11</p> <p>22 / 15 →</p>	<p>← 8 / 25</p> <p>12</p> <p>22 / 15 →</p>
Retail Proj Dwy & Ralph Rd	Imperial Ave & Proj Dwy		
<p>← 8 / 25</p> <p>13</p> <p>22 / 15 →</p>	<p>14</p>		



Heritage at Dahlia Ranch
 Phase 4 Project Trip Assignment

Figure 4-10a

5 CUMULATIVE PROJECT TRAFFIC

This section summarizes the cumulative projects in the study area.

5.1 Cumulative Projects

One cumulative project will contribute traffic to the study area network and is located within the limits of the study area. A brief description of the cumulative project is summarized below.

- 1) *Clark 54* – This project consists of 241 single family dwelling units and 300 multi-family dwelling units. This project is generally bounded by Ralph Road to the north, Neckel Road to the south, Clark Road to the east, and the railroad tracks to the west. This project will be constructed over two phases with the single family homes being built by the Year 2026 and the multi-family homes being built by the Year 2028.

The total trip generation for the cumulative project shown above results in approximately 4,472 daily trips with 317 AM peak-hour trips and 407 PM peak-hour trips.

Figure 5-1 shows the location of the cumulative project. Figures 5-2 and 5-3 illustrate the traffic volumes of the cumulative project in the study area in the Year 2026 and Year 2028, respectively.

LEGEND

1 Clark 54

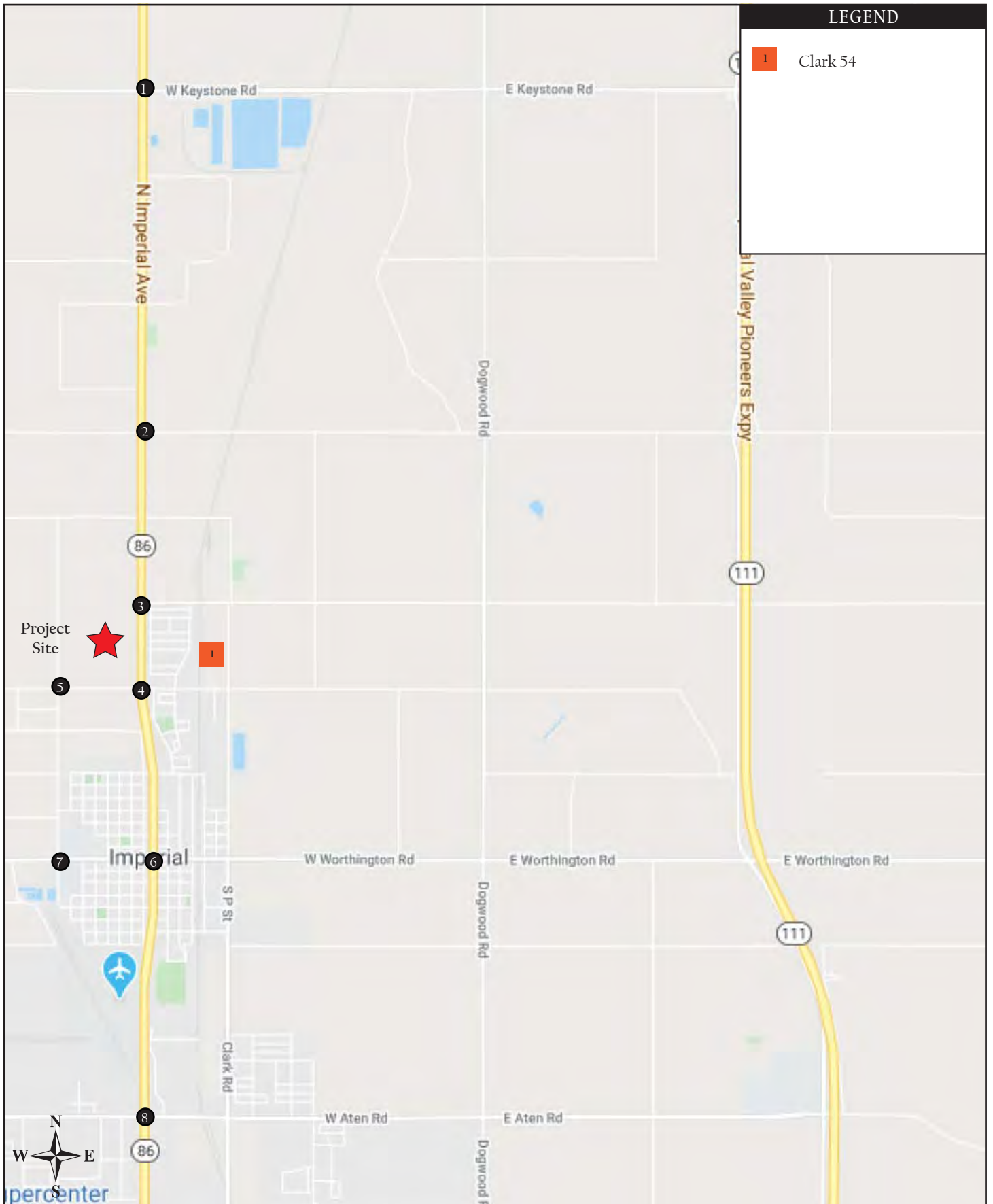

Heritage at Dahlia Ranch

Figure 5-1
Cumulative Project Location Map

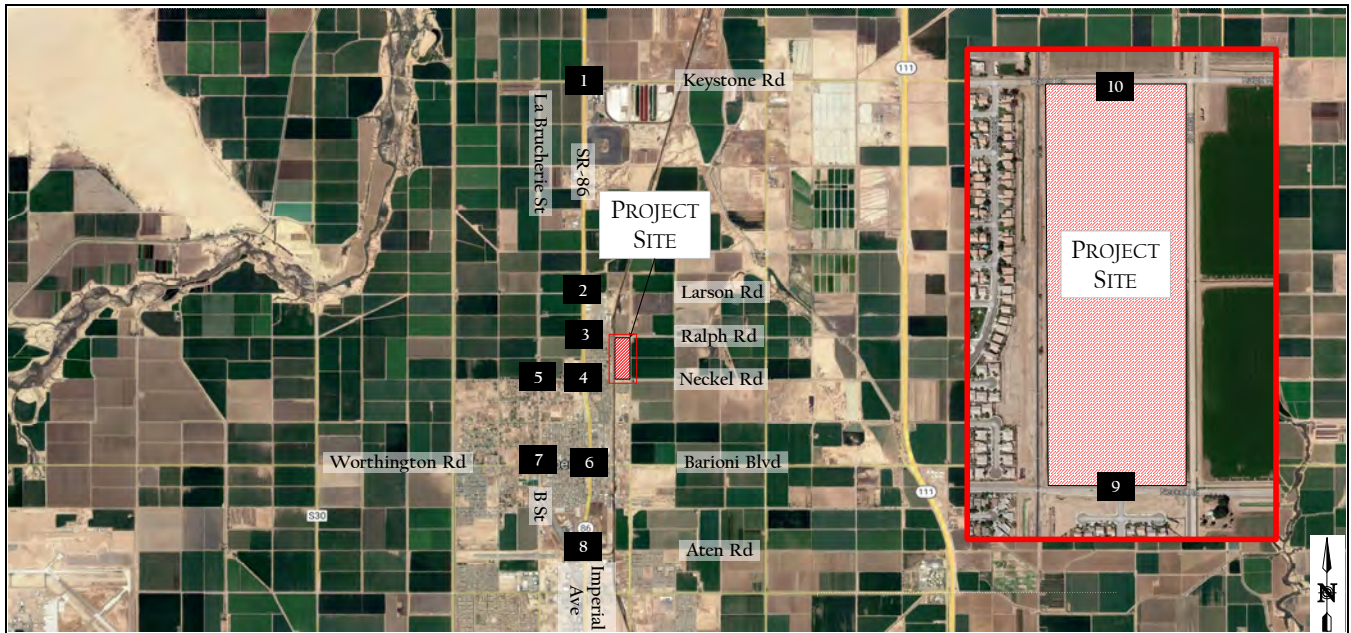

xx / yy - AM / PM Peak-Hour Turning Movement Volumes
 The naming convention for intersections is North / South & East / West

SR-86 & Keystone Rd		SR-86 & Larsen Rd		Imperial Ave & Ralph Rd		Imperial Ave & Neckel Rd					



Heritage at Dahlia Ranch
 Cumulative Project Traffic Volumes - Year 2026

Figure 5-2

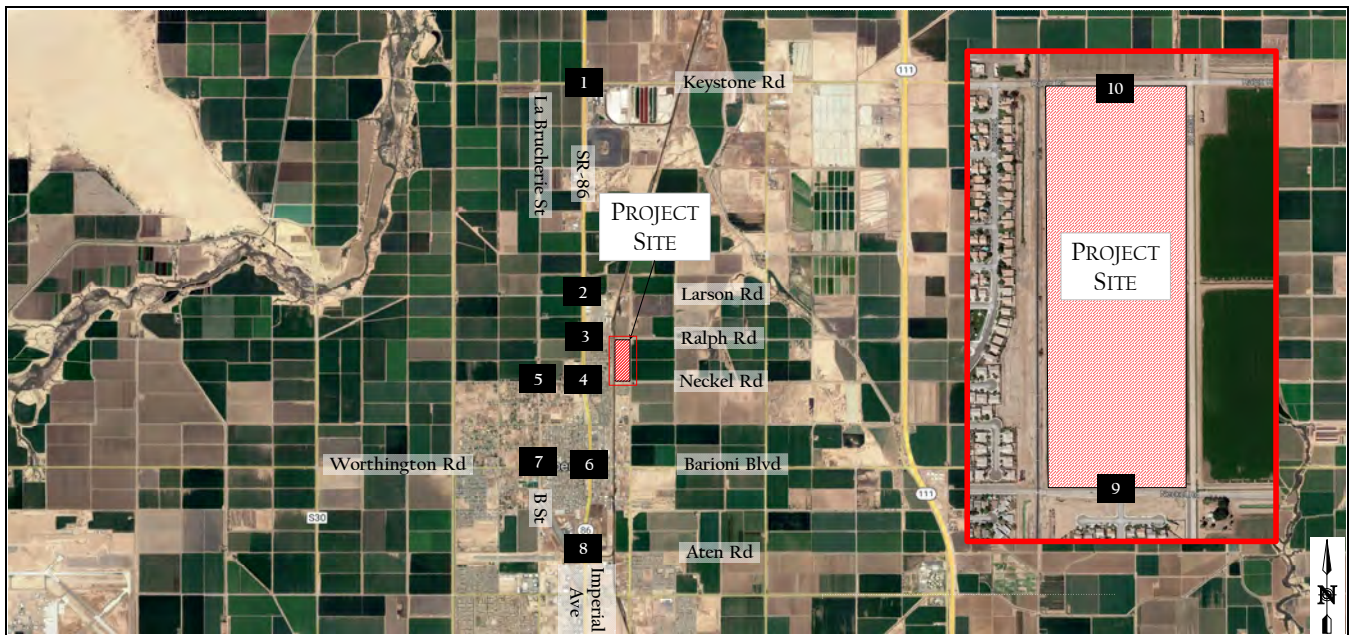

xx / yy - AM / PM Peak-Hour Turning Movement Volumes
 The naming convention for intersections is North / South & East / West

SR-86 & Keystone Rd		SR-86 & Larsen Rd		Imperial Ave & Ralph Rd		Imperial Ave & Neckel Rd	
La Brucherie Rd & Neckel Rd		Imperial Ave & Barioni Blvd / Worthington Rd		B St / La Brucherie Rd & Worthington Rd		Imperial Ave & Aten Rd	
Proj Dwy & Neckel Rd		Proj Dwy & Ralph Rd					
Does not exist		Does not exist					



Heritage at Dahlia Ranch
 Cumulative Project Traffic Volumes - Year 2028

Figure 5-3

6 OPENING YEAR 2023

This section summarizes the operations at the study area intersections, roadway segments, and project driveways with the addition of the Phase 1 project traffic in the anticipated year of opening in 2023.

6.1 Roadway Network

No changes to the existing roadway network are proposed under this condition except at the project driveway along Neckel Road. The Project will construct an eastbound left-turn lane along Neckel Road. **Figure 6-1** illustrates the intersection geometrics with the addition of the Phase 1 Project traffic.

6.2 Traffic Volumes

The Opening Year 2023 Baseline Conditions traffic volumes were developed by applying a regional growth factor and including the cumulative traffic volumes. According to the *Southern California Association of Governments' (SCAG) Profile of Imperial County Report, May 2019*, the population of Imperial County grew by 48,263 people between 2000 and 2018, which corresponds to an annual growth rate of 1.4 percent. This growth rate was applied to the existing traffic volumes for two years to estimate the Year 2023 baseline conditions. **Appendix E** contains of the *SCAG Profile of Imperial County Report*.

Figure 6-2 illustrates the Opening Year 2023 Baseline traffic volumes. **Figure 6-3** illustrates the Opening Year 2023 Plus Phase 1 Project traffic volumes.

6.3 Intersection Analysis

Table 6-1 displays the LOS analysis results for the study intersections and project driveways under Opening Year 2023 Baseline and Plus Phase 1 Project conditions.

Appendix C contains the intersection LOS worksheets.

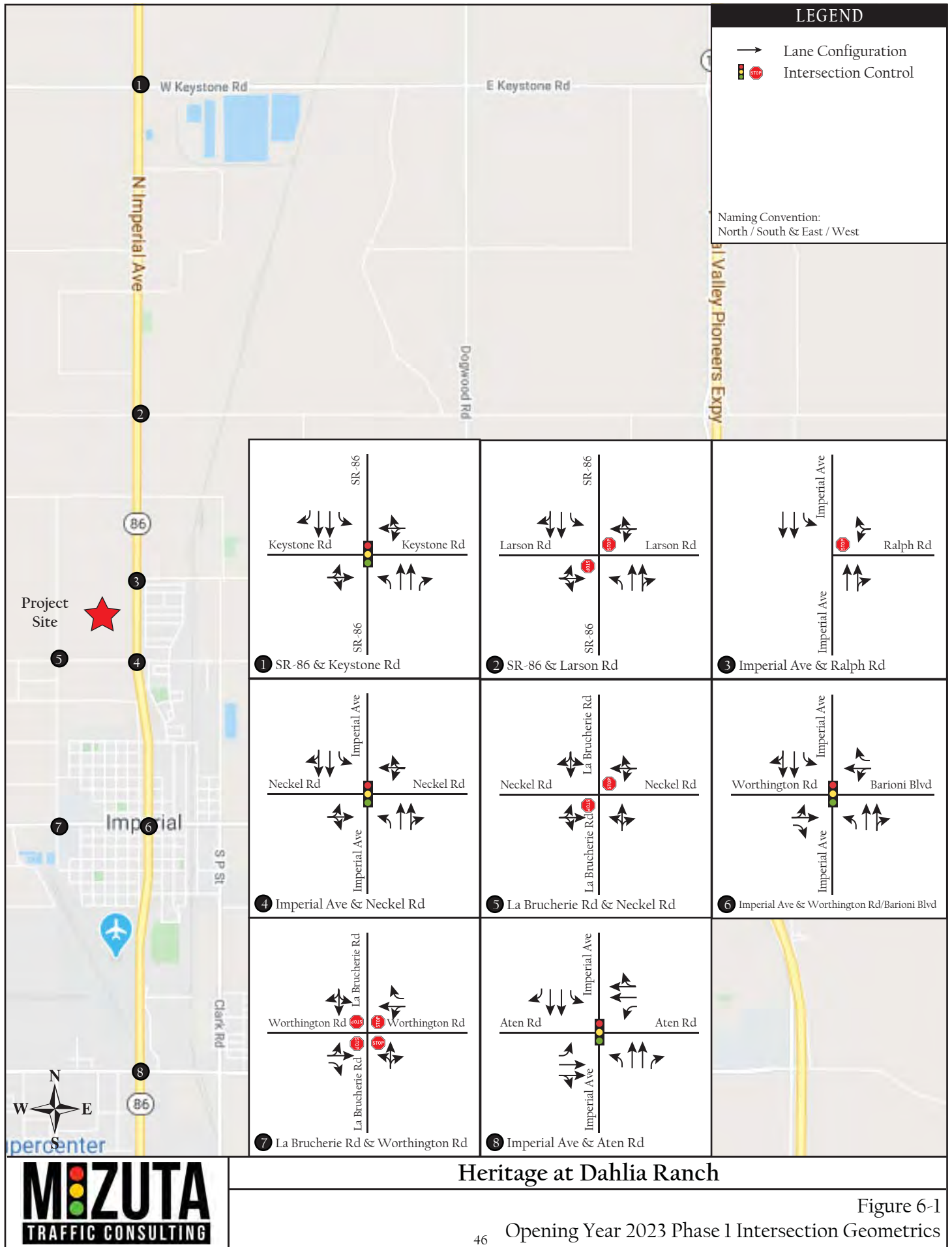

LEGEND

- Lane Configuration
- ⬮⬮⬮ Intersection Control

Naming Convention:
North / South & East / West

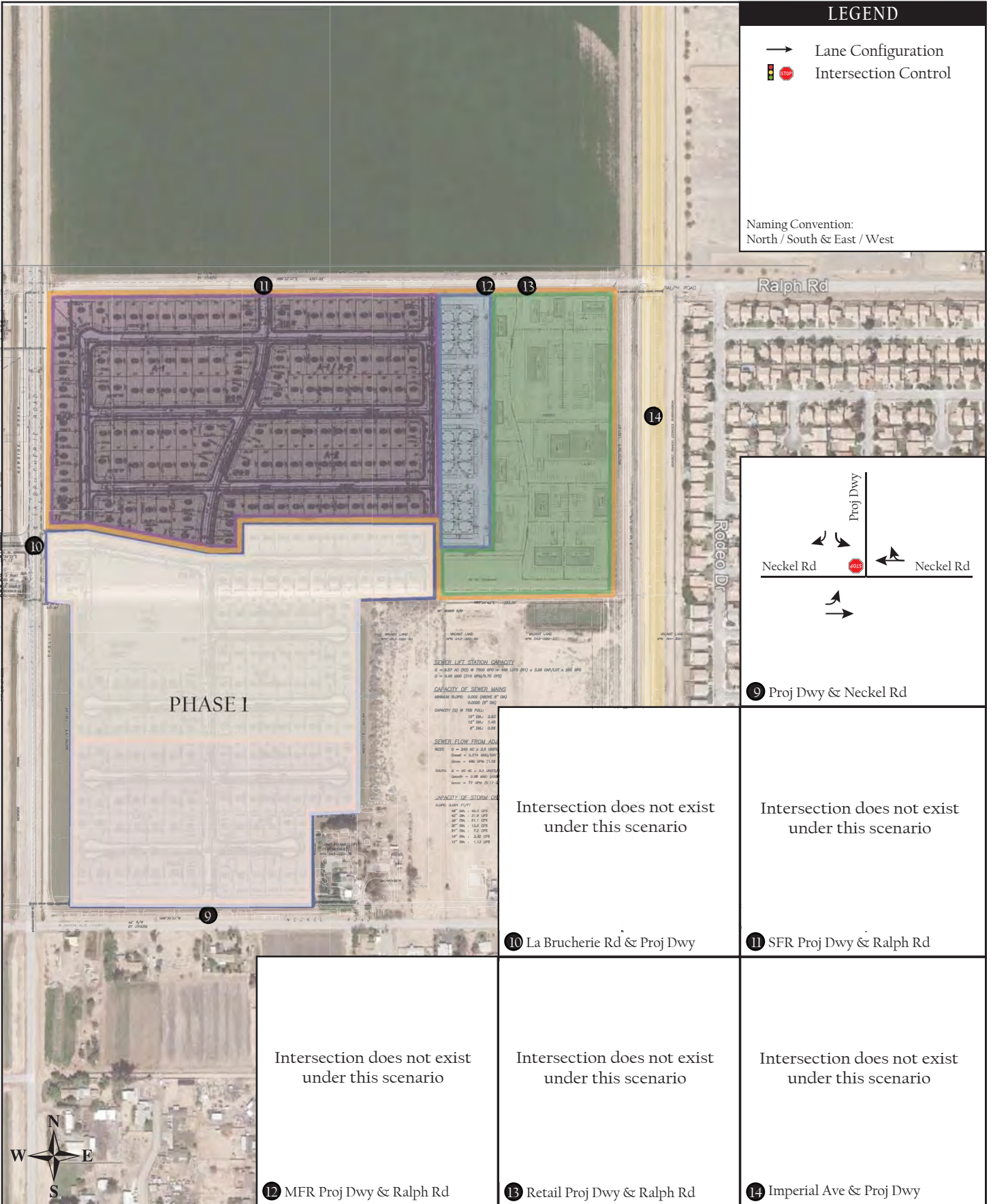

Heritage at Dahlia Ranch

Figure 6-1a

Opening Year 2023 Phase I Intersection Geometrics

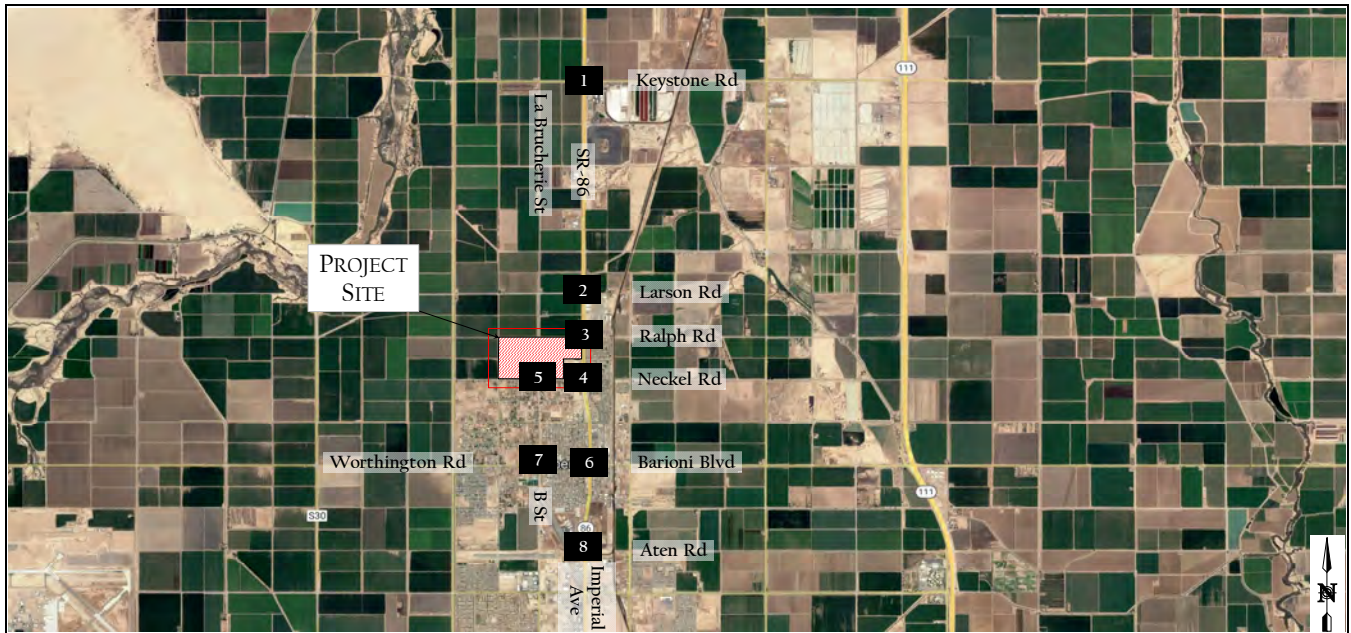

xx / yy - AM / PM Peak-Hour Turning Movement Volumes
 The naming convention for intersections is North / South & East / West

SR-86 & Keystone Rd		SR-86 & Larsen Rd		Imperial Ave & Ralph Rd		Imperial Ave & Neckel Rd	
37 / 34 512 / 542 45 / 52 42 / 37 24 / 27 19 / 33	1	7 / 17 517 / 578 1 / 6 5 / 5 2 / 0 1 / 7	2	500 / 542 20 / 30 23 / 10 59 / 20	3	31 / 28 511 / 496 14 / 29 56 / 46 64 / 20 142 / 82	4
33 / 41 33 / 12 11 / 20 19 / 10 439 / 523 49 / 26	1	20 / 6 3 / 4 2 / 0 0 / 1 506 / 561 1 / 7	2	484 / 562 41 / 30	3	34 / 12 43 / 26 12 / 4 8 / 11 442 / 555 65 / 83	4
La Brucherie Rd & Neckel Rd		Imperial Ave & Barioni Blvd / Worthington Rd		B St / La Brucherie Rd & Worthington Rd		Imperial Ave & Aten Rd	
1 / 7 2 / 5 1 / 0 0 / 1 44 / 44 60 / 23	5	56 / 63 630 / 593 39 / 27 77 / 51 132 / 112 54 / 54	6	64 / 24 31 / 5 106 / 37 77 / 34 301 / 215 11 / 27	7	375 / 209 670 / 538 142 / 112 141 / 122 299 / 288 131 / 178	8
4 / 2 41 / 38 23 / 8 7 / 5 6 / 6 42 / 10	5	70 / 48 136 / 74 212 / 105 93 / 112 465 / 666 50 / 14	6	61 / 26 390 / 187 119 / 33 0 / 1 1 / 0	7	186 / 189 337 / 276 63 / 68 61 / 78 343 / 664 67 / 149	8

	<p>Heritage at Dahlia Ranch</p> <p>Opening Year 2023 Baseline Traffic Volumes</p>	<p>Figure 6-2</p>
--	---	-------------------

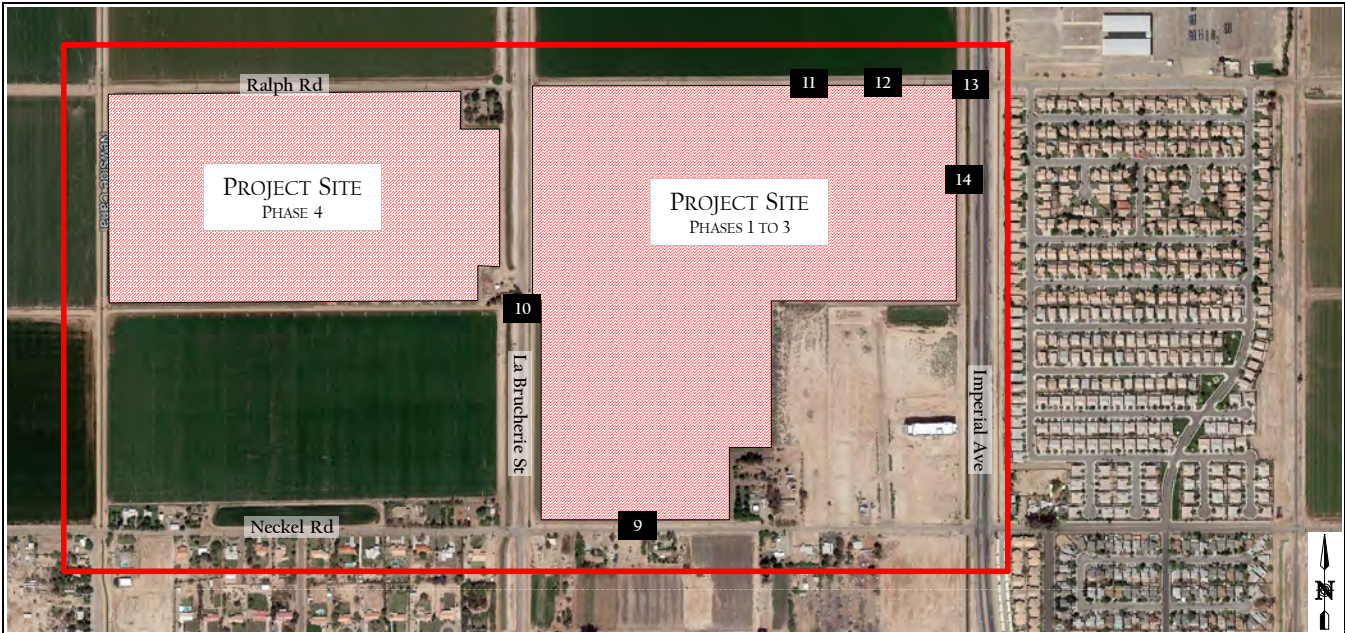

xx / yy - AM / PM Peak-Hour Turning Movement Volumes
 The naming convention for intersections is North / South & East / West

Proj Dwy & Neckel Rd	La Brucherie Rd & Proj Dwy	SFR Proj Dwy & Ralph Rd	MFR Proj Dwy & Ralph Rd
Does not exist	Does not exist	Does not exist	Does not exist
Retail Proj Dwy & Ralph Rd	Imperial Ave & Proj Dwy		
Does not exist	Does not exist		



Heritage at Dahlia Ranch
 Opening Year 2023 Baseline Traffic Volumes

Figure 6-2a

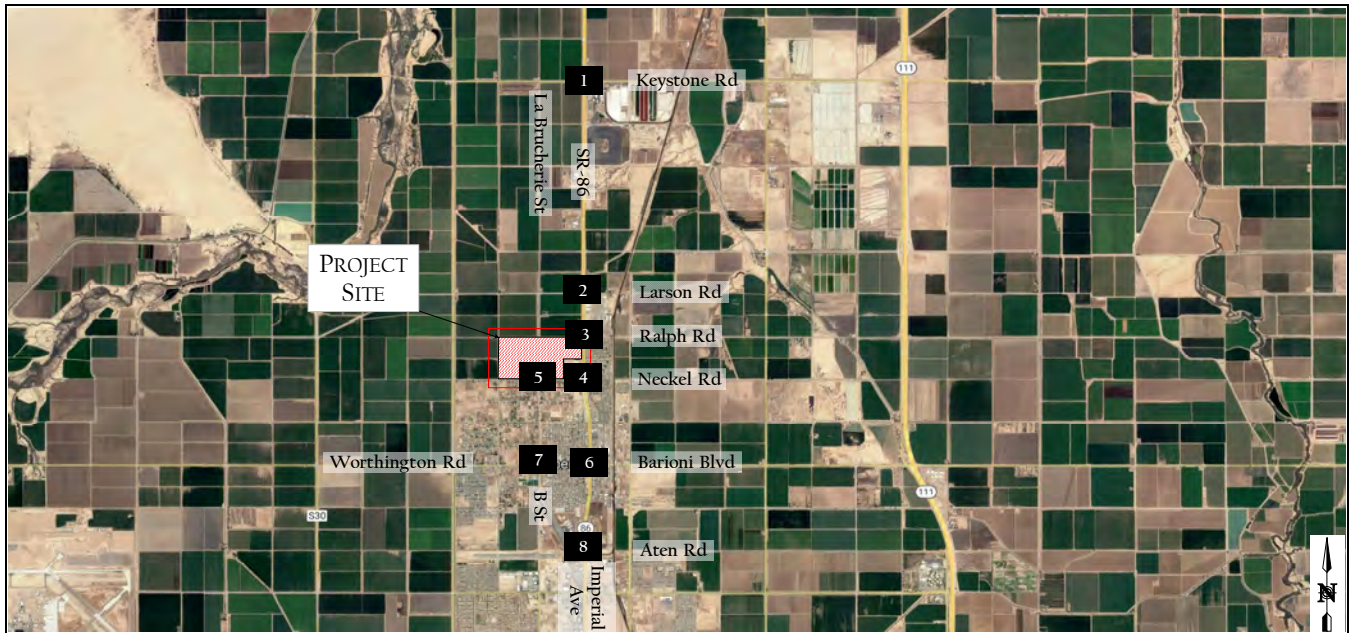

xx / yy - AM / PM Peak-Hour Turning Movement Volumes
 The naming convention for intersections is North / South & East / West

SR-86 & Keystone Rd		SR-86 & Larsen Rd		Imperial Ave & Ralph Rd		Imperial Ave & Neckel Rd	
37 / 34 517 / 559 45 / 52 42 / 37 24 / 27 19 / 33	7 / 17 522 / 595 1 / 6 5 / 5 2 / 0 1 / 7	505 / 559 20 / 30 23 / 10 59 / 20	36 / 45 511 / 496 14 / 29 56 / 46 64 / 20 142 / 82				
33 / 41 33 / 12 11 / 20 19 / 10 454 / 533 49 / 26	20 / 6 3 / 4 2 / 0 0 / 1 521 / 571 1 / 7	499 / 572 41 / 30	49 / 22 43 / 26 64 / 38 26 / 70 442 / 555 65 / 83				
La Brucherie Rd & Neckel Rd		Imperial Ave & Barioni Blvd / Worthington Rd		B St / La Brucherie Rd & Worthington Rd		Imperial Ave & Aten Rd	
1 / 7 2 / 5 1 / 0 0 / 1 44 / 44 67 / 28	56 / 63 674 / 622 46 / 32 80 / 59 132 / 112 54 / 54	71 / 29 31 / 5 106 / 37 77 / 34 301 / 215 11 / 27	382 / 214 700 / 557 149 / 117 144 / 130 299 / 288 131 / 178				
4 / 2 41 / 38 23 / 8 7 / 5 6 / 6 45 / 18	70 / 48 136 / 74 212 / 105 93 / 112 480 / 716 50 / 14	64 / 34 390 / 187 119 / 33 0 / 1 1 / 0	189 / 197 337 / 276 63 / 68 61 / 78 353 / 698 67 / 149				

	Heritage at Dahlia Ranch Opening Year 2023 Plus Phase I Project Traffic Volumes	Figure 6-3
--	---	------------

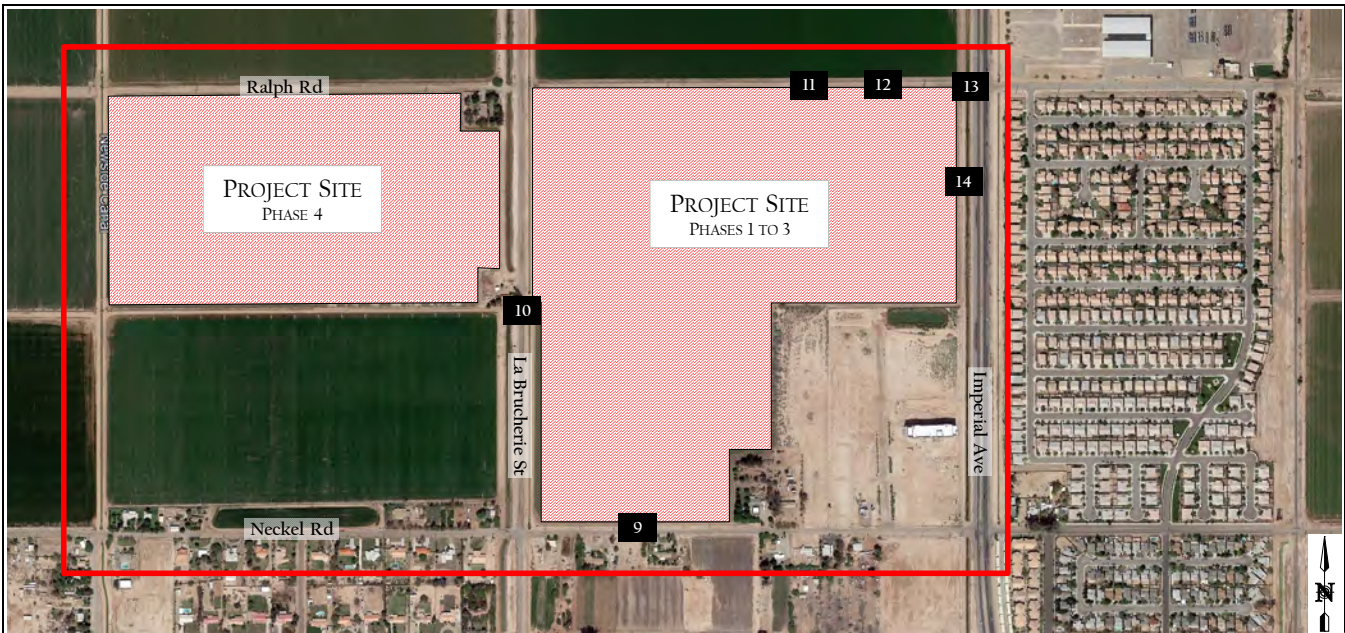

xx / yy - AM / PM Peak-Hour Turning Movement Volumes
 The naming convention for intersections is North / South & East / West

Proj Dwy & Neckel Rd	La Brucherie Rd & Proj Dwy	SFR Proj Dwy & Ralph Rd	MFR Proj Dwy & Ralph Rd
	Does not exist	Does not exist	Does not exist
Retail Proj Dwy & Ralph Rd	Imperial Ave & Proj Dwy		
Does not exist	Does not exist		



Heritage at Dahlia Ranch
 Opening Year 2023 Plus Phase 1 Project Traffic Volumes

Figure 6-3a

**Table 6-1
Opening Year 2023 Peak Hour Intersection LOS Summary**

#	Intersection	Traffic Control	Peak Hour	Opening Year 2023		Opening Year 2023 w/Phase I Proj		Δ in Delay	Improvement?
				Delay ¹	LOS ²	Delay ¹	LOS ²		
1	SR-86 & Keystone Rd	Signal	AM	9.4	A	9.3	A	-0.1	No
			PM	9.3	A	9.3	A	0.0	No
2	SR-86 & Larson Rd	TWSC	AM	15.1	C	15.2	C	0.1	No
			PM	17.1	C	17.4	C	0.3	No
3	Imperial Ave & Ralph Rd	TWSC	AM	19.4	C	19.9	C	0.5	No
			PM	18.6	C	19.1	C	0.5	No
4	Imperial Ave & Neckel Rd	Signal	AM	18.2	B	21.1	C	2.9	No
			PM	14.7	B	17.2	B	2.5	No
5	La Brucherie Rd & Neckel Rd	TWSC	AM	10.2	B	10.3	B	0.1	No
			PM	9.7	A	9.7	A	0.0	No
6	Imperial Ave & Worthington Rd/Barioni Blvd	Signal	AM	28.0	C	29.5	C	1.5	No
			PM	21.6	C	22.4	C	0.8	No
7	La Brucherie Rd & Worthington Rd	AWSC	AM	19.3	C	19.8	C	0.5	No
			PM	10.5	B	10.7	B	0.2	No
8	Imperial Ave & Aten Rd	Signal	AM	30.7	C	31.6	C	0.9	No
			PM	24.8	C	26.0	C	1.2	No
9	Proj Dwy & Neckel Rd	OWSC	AM	DNE		10.2	B	10.2	No
			PM			9.7	A	9.7	No
10	La Brucherie Rd & Proj Dwy	OWSC	AM	DNE					
			PM						
11	SFR Proj Dwy & Ralph Rd	OWSC	AM	DNE					
			PM						
12	MFR Proj Dwy & Ralph Rd	OWSC	AM	DNE					
			PM						
13	Retail Proj Dwy & Ralph Rd	OWSC	AM	DNE					
			PM						
14	Imperial Ave & Proj Dwy	OWSC	AM	DNE					
			PM						

Notes:

OWSC: One-Way Stopped Control, TWSC: Two-Way Stopped Control, AWSC: All-Way Stopped Control

1. Delays are reported as the average control delay for the entire intersection at signalized intersections and the worst movement at unsignalized intersections.

2. LOS calculations are based on the methodology outlined in the *Highway Capacity Manual 6th Edition (HCM6)* and performed using Synchro II.

As shown in the table, all intersections, including the project driveway, are expected to operate at LOS C or better during the weekday peak-hours with the addition of the Project traffic. As a result, no additional intersection improvements are required and/or recommended.

6.4 Roadway Segment Analysis

Table 6-2 displays the LOS analysis for the study area roadway segments under the Opening Year 2023 with and without the Phase I Project traffic.

Table 6-2
Opening Year 2023 Roadway LOS Summary

Roadway Segment	Opening Year 2023			Opening Year 2023 w/Phase I Proj			Δ in V/C	Improvement?
	ADT	v/c Ratio	LOS	ADT	v/c Ratio	LOS		
SR-86								
North of Keystone Rd	15,298	0.41	B	15,549	0.42	B	0.007	No
Keystone Rd to Larsen Rd	14,603	0.40	A	14,854	0.40	B	0.006	No
Larsen Rd to Ralph Rd	14,031	0.38	A	14,282	0.39	A	0.007	No
Imperial Ave								
Ralph Rd to Neckel Rd	14,450	0.39	A	14,701	0.40	A	0.006	No
Neckel Rd to Worthington Rd	18,653	0.50	B	19,532	0.53	B	0.024	No
Worthington Rd to Aten Rd	20,546	0.56	B	21,300	0.58	B	0.021	No
South of Aten Rd	21,942	0.59	B	22,444	0.61	B	0.014	No

As shown in the table, all roadway segments would continue to function at LOS B or better with the addition of the Phase I Project traffic. As a result, no additional improvements are required and/or recommended.

7 OPENING YEAR 2024

This section summarizes the operations at the study area intersections, roadway segments, and project driveways with the addition of the Phase 2 project traffic in the anticipated year of opening in 2024.

7.1 Roadway Network

No changes to the existing roadway network are proposed under this condition except at the project driveway along La Brucherie Road. The Project will construct a southbound left-turn lane along La Brucherie Road. **Figure 7-1** illustrates the intersection geometrics with the addition of the Phase 2 Project traffic.

7.2 Traffic Volumes

The Opening Year 2024 Baseline Conditions traffic volumes were developed by applying the annual 1.4 percent regional growth factor and including the cumulative traffic volumes. This growth rate was applied to the existing traffic volumes for three years to estimate the Year 2024 baseline conditions.

Figure 7-2 illustrates the Opening Year 2024 Baseline traffic volumes. **Figure 7-3** illustrates the Opening Year 2024 Plus Phases 1 & 2 Project traffic volumes.

7.3 Intersection Analysis

Table 7-1 displays the LOS analysis results for the study intersections and project driveways under Opening Year 2024 Baseline and Plus Phases 1 & 2 Project conditions.

Appendix C contains the intersection LOS worksheets.

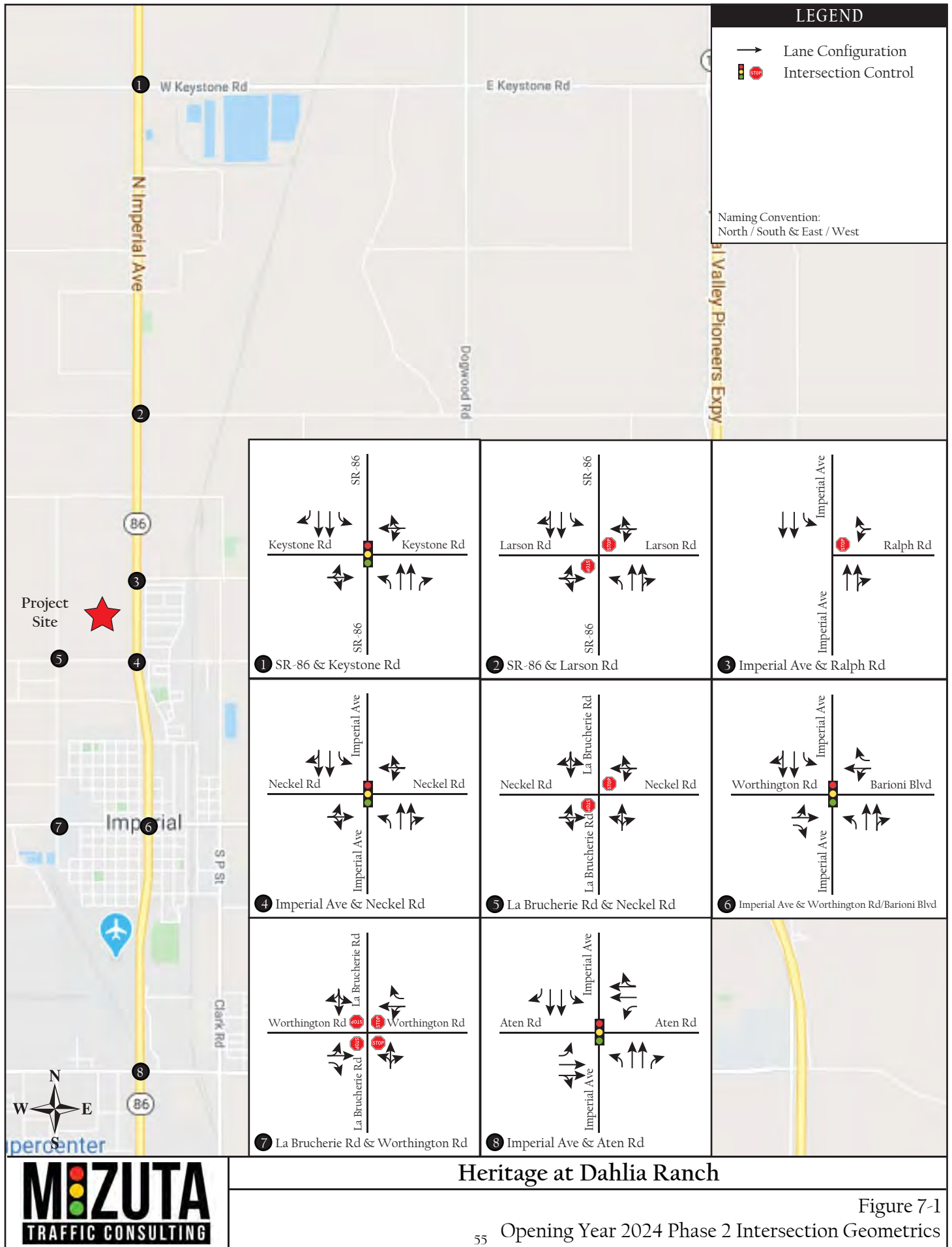

LEGEND

- Lane Configuration
- ⬮⬮ Intersection Control

Naming Convention:
North / South & East / West

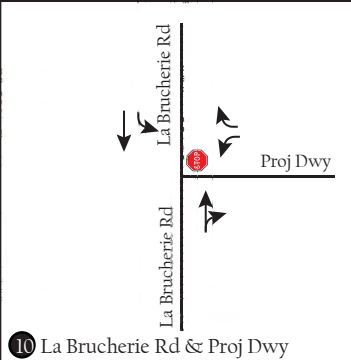
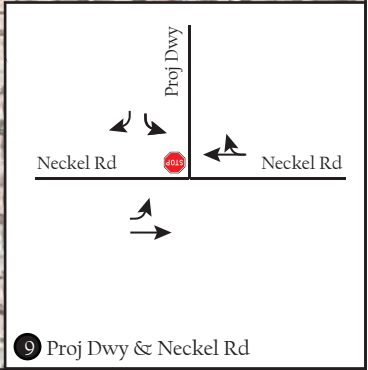
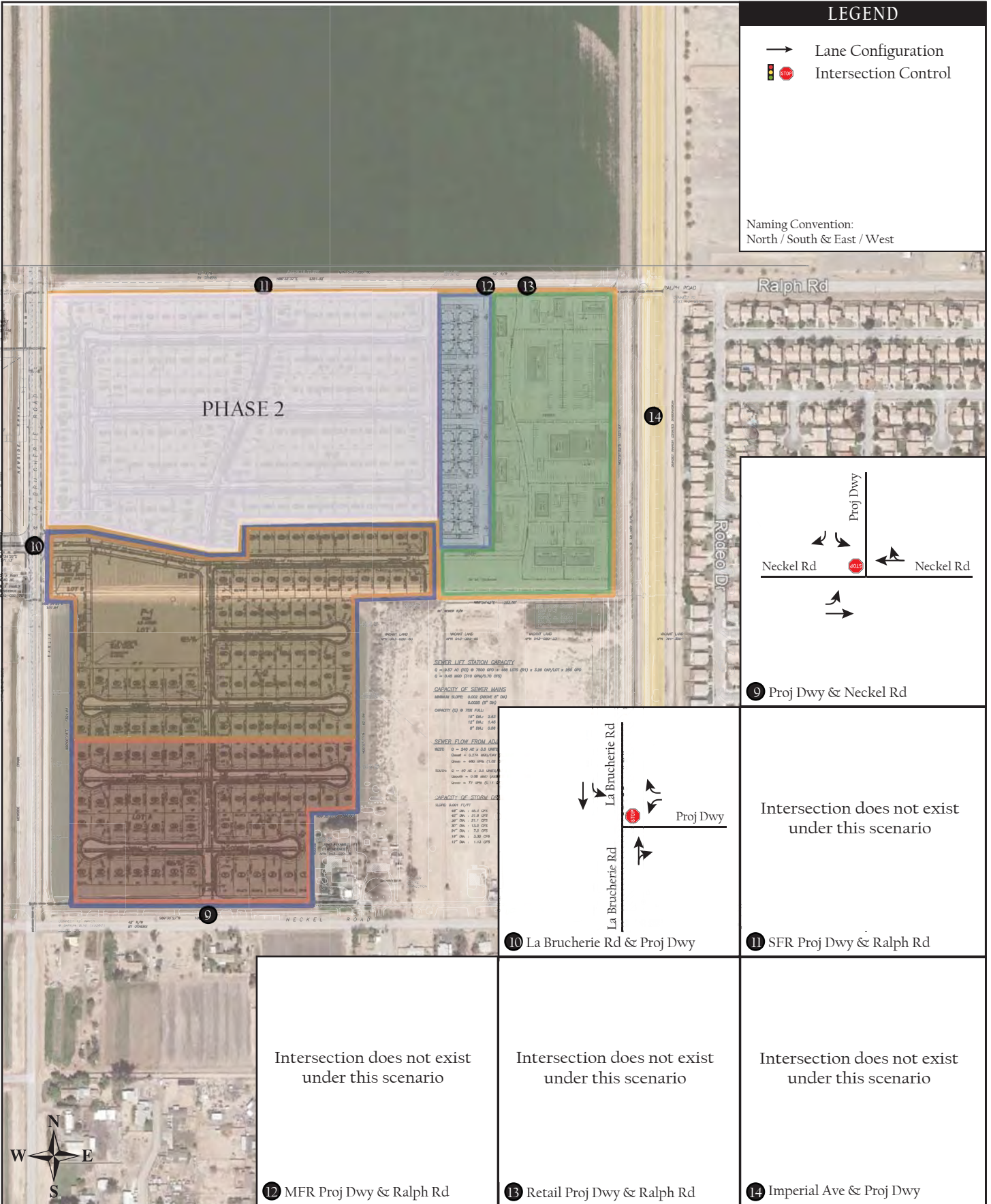

Intersection does not exist under this scenario

11 SFR Proj Dwy & Ralph Rd

Intersection does not exist under this scenario

12 MFR Proj Dwy & Ralph Rd

Intersection does not exist under this scenario

13 Retail Proj Dwy & Ralph Rd

Intersection does not exist under this scenario

14 Imperial Ave & Proj Dwy



Heritage at Dahlia Ranch

Figure 7-1a

Opening Year 2024 Phase 2 Intersection Geometrics

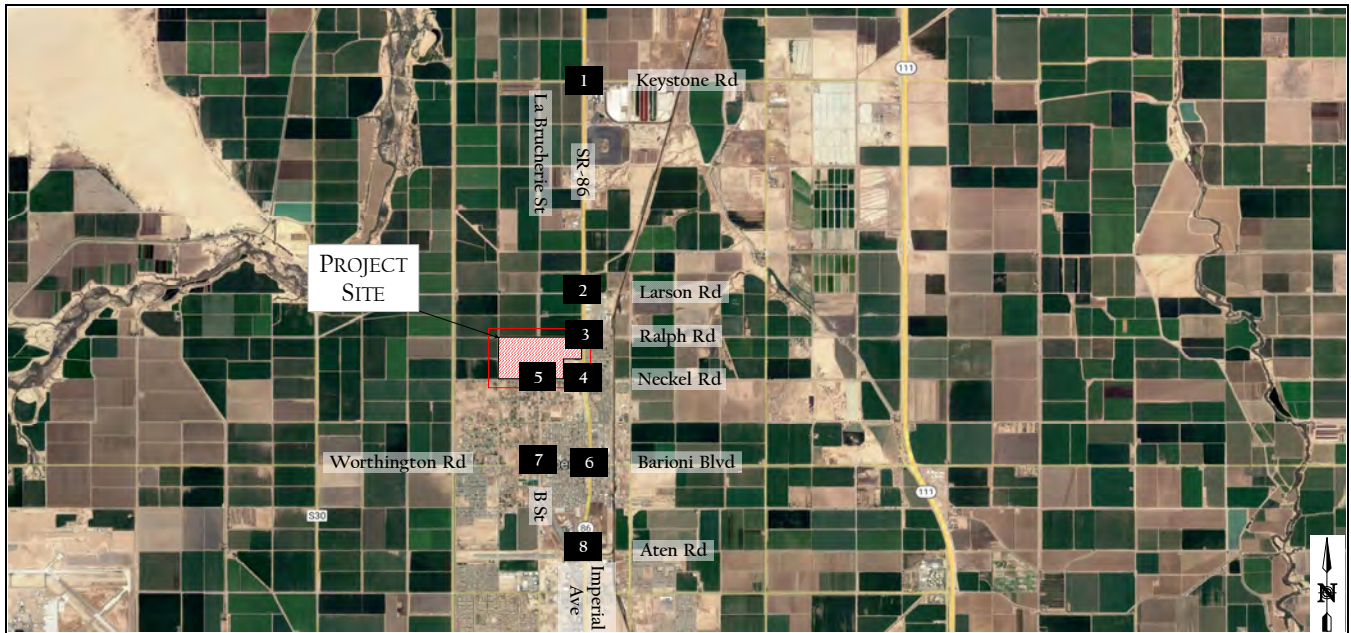

xx / yy - AM / PM Peak-Hour Turning Movement Volumes
 The naming convention for intersections is North / South & East / West

SR-86 & Keystone Rd		SR-86 & Larsen Rd		Imperial Ave & Ralph Rd		Imperial Ave & Neckel Rd	
38 / 34 519 / 549 46 / 53 ↙ ↘ ↘ ↙ 43 / 38 24 / 27 19 / 33	1	7 / 18 524 / 586 1 / 6 ↙ ↘ ↘ ↙ 5 / 5 2 / 0 1 / 7	2	507 / 549 20 / 30 ↙ ↘ ↘ ↙ 23 / 10 59 / 20	3	31 / 28 518 / 503 15 / 29 ↙ ↘ ↘ ↙ 56 / 47 65 / 20 144 / 83	4
33 / 42 33 / 13 11 / 20 ↙ ↘ ↘ ↙ 19 / 10 445 / 531 50 / 26	5	20 / 6 3 / 4 2 / 0 ↙ ↘ ↘ ↙ 0 / 1 513 / 569 1 / 7	6	491 / 570 42 / 30 ↙ ↘ ↘ ↙ 34 / 13 44 / 26 13 / 4	7	8 / 11 448 / 563 66 / 84	8
La Brucherie Rd & Neckel Rd		Imperial Ave & Barioni Blvd / Worthington Rd		B St / La Brucherie Rd & Worthington Rd		Imperial Ave & Aten Rd	
1 / 7 2 / 5 1 / 0 ↙ ↘ ↘ ↙ 0 / 1 45 / 45 60 / 23	5	56 / 64 639 / 602 40 / 27 ↙ ↘ ↘ ↙ 78 / 52 133 / 114 55 / 55	6	65 / 24 31 / 5 107 / 38 ↙ ↘ ↘ ↙ 78 / 34 305 / 218 11 / 27	7	381 / 212 680 / 545 144 / 114 ↙ ↘ ↘ ↙ 143 / 124 303 / 292 132 / 180	8
4 / 2 42 / 39 23 / 8 ↙ ↘ ↘ ↙ 7 / 5 6 / 6 43 / 10	5	71 / 49 138 / 75 215 / 106 ↙ ↘ ↘ ↙ 94 / 114 471 / 676 51 / 15	6	62 / 26 395 / 190 121 / 33 ↙ ↘ ↘ ↙ 0 / 1 1 / 0	7	189 / 192 342 / 279 64 / 69 ↙ ↘ ↘ ↙ 62 / 79 348 / 674 68 / 151	8

	Heritage at Dahlia Ranch Opening Year 2024 Baseline Traffic Volumes	Figure 7-2
--	--	------------

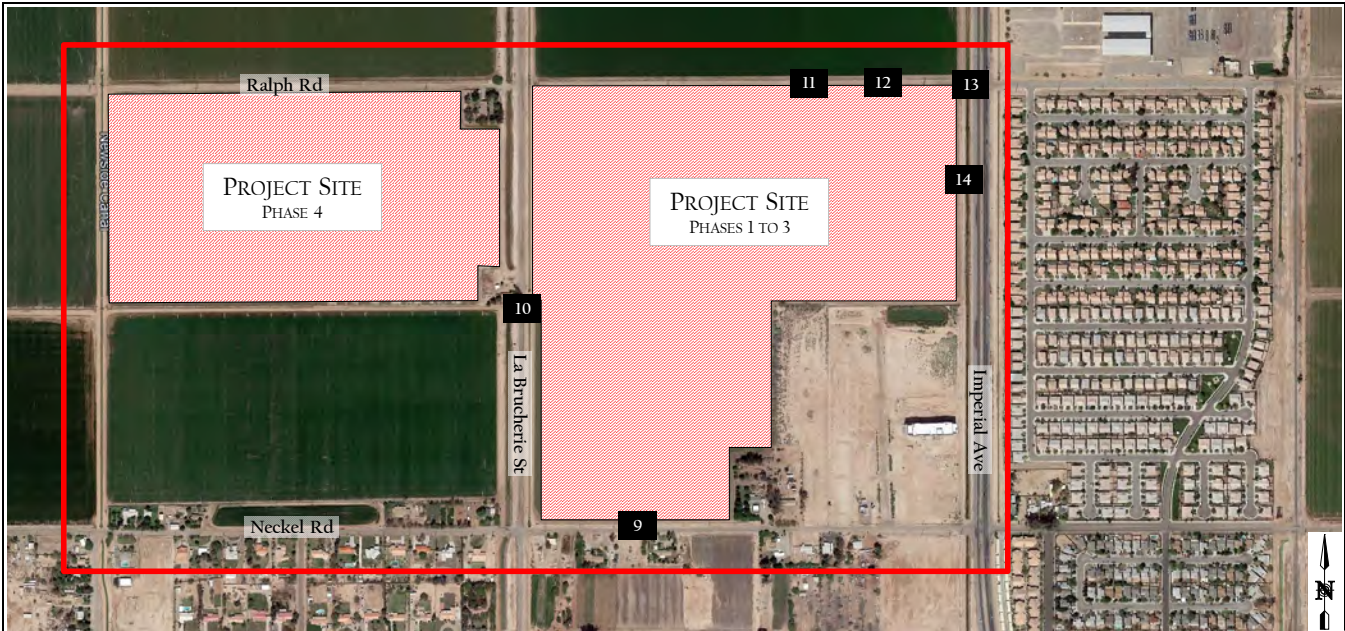

xx / yy - AM / PM Peak-Hour Turning Movement Volumes
 The naming convention for intersections is North / South & East / West

Proj Dwy & Neckel Rd	La Brucherie Rd & Proj Dwy	SFR Proj Dwy & Ralph Rd	MFR Proj Dwy & Ralph Rd
Does not exist	Does not exist	Does not exist	Does not exist
Retail Proj Dwy & Ralph Rd	Imperial Ave & Proj Dwy		
Does not exist	Does not exist		



Heritage at Dahlia Ranch
 Opening Year 2024 Baseline Traffic Volumes

Figure 7-2a

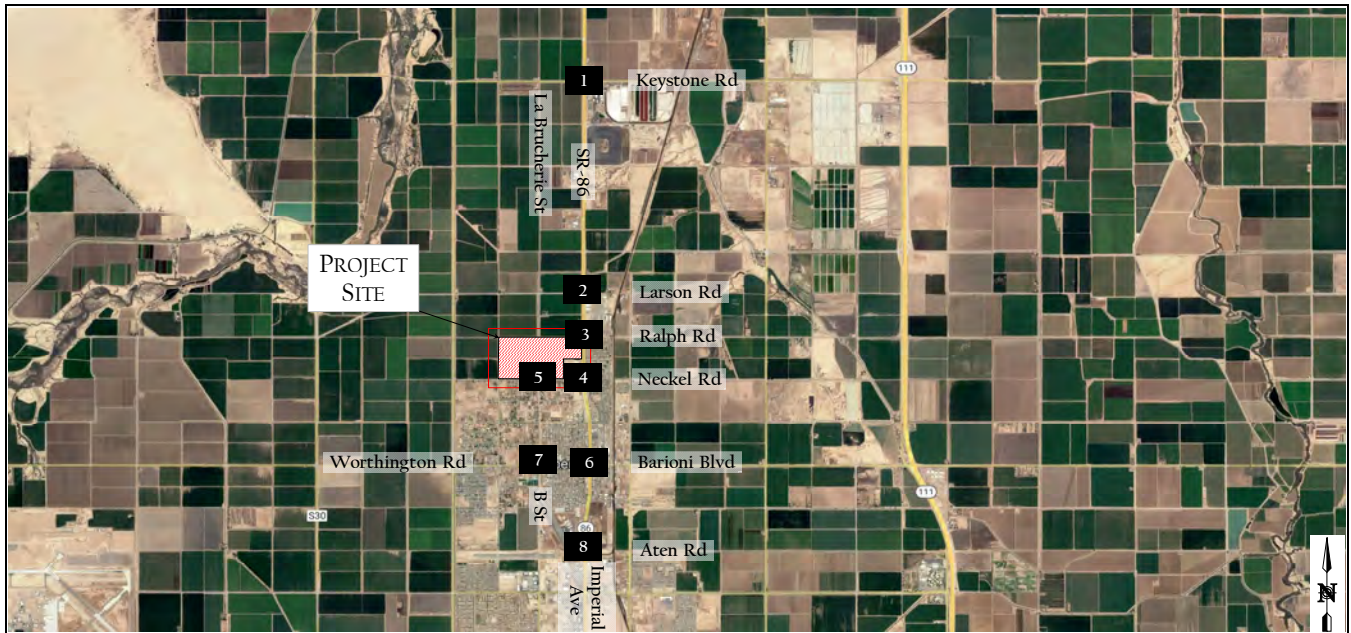

xx / yy - AM / PM Peak-Hour Turning Movement Volumes
 The naming convention for intersections is North / South & East / West

SR-86 & Keystone Rd		SR-86 & Larsen Rd		Imperial Ave & Ralph Rd		Imperial Ave & Neckel Rd					
38 / 34 ↘ ↙ 529 / 383 ↘ ↙ 46 / 53 ↘ ↙ 1	↘ ↙ 43 / 38 ↘ ↙ 24 / 27 ↘ ↙ 19 / 33	7 / 18 ↘ ↙ 334 / 620 ↘ ↙ 1 / 6 ↘ ↙ 2	↘ ↙ 5 / 5 ↘ ↙ 2 / 0 ↘ ↙ 1 / 7	517 / 583 ↘ ↙ 20 / 30 ↘ ↙ 23 / 10 ↘ ↙ 59 / 20 3	41 / 62 ↘ ↙ 518 / 503 ↘ ↙ 15 / 29 ↘ ↙ 56 / 47 ↘ ↙ 65 / 20 ↘ ↙ 144 / 83 4	33 / 42 ↘ ↙ 33 / 13 ↘ ↙ 11 / 20 ↘ ↙ 19 / 10 ↘ ↙ 475 / 551 ↘ ↙ 50 / 26 5	20 / 6 ↘ ↙ 3 / 4 ↘ ↙ 2 / 0 ↘ ↙ 0 / 1 ↘ ↙ 543 / 589 ↘ ↙ 1 / 7 6	521 / 590 ↘ ↙ 42 / 30 ↘ ↙ 64 / 33 ↘ ↙ 44 / 26 ↘ ↙ 117 / 72 ↘ ↙ 44 / 129 ↘ ↙ 448 / 563 ↘ ↙ 66 / 84 7	64 / 33 ↘ ↙ 44 / 26 ↘ ↙ 117 / 72 ↘ ↙ 44 / 129 ↘ ↙ 448 / 563 ↘ ↙ 66 / 84 8		
La Brucherie Rd & Neckel Rd		Imperial Ave & Barioni Blvd / Worthington Rd		B St / La Brucherie Rd & Worthington Rd		Imperial Ave & Aten Rd					
1 / 7 ↘ ↙ 9 / 10 ↘ ↙ 23 / 14 ↘ ↙ 5	↘ ↙ 8 / 26 ↘ ↙ 45 / 45 ↘ ↙ 67 / 28	56 / 64 ↘ ↙ 727 / 660 ↘ ↙ 54 / 37 ↘ ↙ 6	↘ ↙ 84 / 68 ↘ ↙ 133 / 114 ↘ ↙ 55 / 55	79 / 34 ↘ ↙ 31 / 5 ↘ ↙ 107 / 38 ↘ ↙ 7	↘ ↙ 78 / 34 ↘ ↙ 305 / 218 ↘ ↙ 11 / 27	395 / 222 ↘ ↙ 740 / 583 ↘ ↙ 158 / 124 ↘ ↙ 8	↘ ↙ 149 / 140 ↘ ↙ 303 / 292 ↘ ↙ 132 / 180	4 / 2 ↘ ↙ 42 / 39 ↘ ↙ 23 / 8 ↘ ↙ 7 / 5 ↘ ↙ 9 / 14 ↘ ↙ 46 / 18 5	71 / 49 ↘ ↙ 138 / 75 ↘ ↙ 215 / 106 ↘ ↙ 94 / 114 ↘ ↙ 501 / 776 ↘ ↙ 51 / 15 6	68 / 42 ↘ ↙ 395 / 190 ↘ ↙ 121 / 33 ↘ ↙ 0 / 1 ↘ ↙ 1 / 0 7	195 / 208 ↘ ↙ 342 / 279 ↘ ↙ 64 / 69 ↘ ↙ 62 / 79 ↘ ↙ 368 / 742 ↘ ↙ 68 / 151 8

	<p>Heritage at Dahlia Ranch</p> <p>Opening Year 2024 Plus Phases 1 & 2 Project Traffic Volumes</p>	<p>Figure 7-3</p>
--	--	-------------------

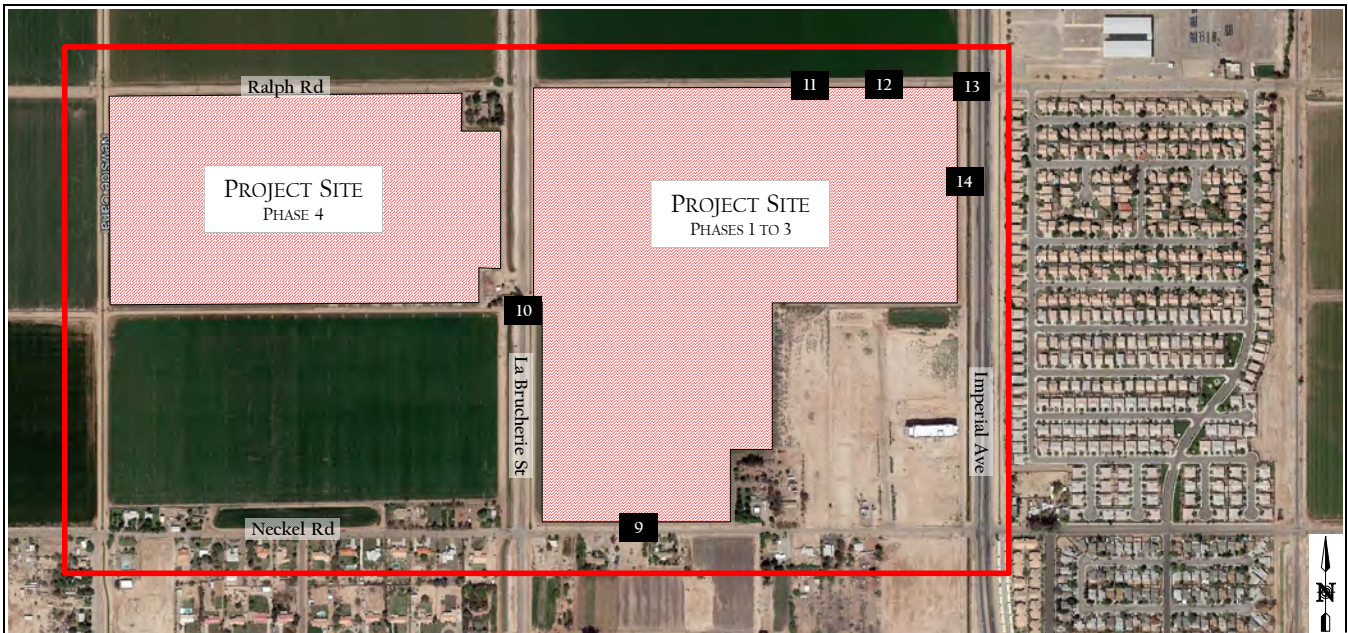

xx / yy - AM / PM Peak-Hour Turning Movement Volumes
 The naming convention for intersections is North / South & East / West

Proj Dwy & Neckel Rd		La Brucherie Rd & Proj Dwy		SFR Proj Dwy & Ralph Rd		MFR Proj Dwy & Ralph Rd	
				Does not exist		Does not exist	
Retail Proj Dwy & Ralph Rd		Imperial Ave & Proj Dwy		Does not exist			



Heritage at Dahlia Ranch
 Opening Year 2024 Plus Phases 1 & 2 Project Traffic Volumes

Figure 7-3a

Table 7-1
Opening Year 2024 Peak Hour Intersection LOS Summary

#	Intersection	Traffic Control	Peak Hour	Opening Year 2024		Opening Year 2024 w/Phases 1&2 Proj		Δ in Delay	Improvement?
				Delay ¹	LOS ²	Delay ¹	LOS ²		
1	SR-86 & Keystone Rd	Signal	AM	9.4	A	9.3	A	-0.1	No
			PM	9.3	A	9.3	A	0.0	No
2	SR-86 & Larson Rd	TWSC	AM	15.2	C	15.5	C	0.3	No
			PM	17.3	C	17.9	C	0.6	No
3	Imperial Ave & Ralph Rd	TWSC	AM	19.7	C	20.8	C	1.1	No
			PM	18.9	C	19.8	C	0.9	No
4	Imperial Ave & Neckel Rd	Signal	AM	18.4	B	24.9	C	6.5	No
			PM	14.8	B	20.6	C	5.8	No
5	La Brucherie Rd & Neckel Rd	TWSC	AM	10.3	B	11.1	B	0.8	No
			PM	9.7	A	10.1	B	0.4	No
6	Imperial Ave & Worthington Rd/Barioni Blvd	Signal	AM	28.8	C	32.3	C	3.5	No
			PM	22.0	C	24.0	C	2.0	No
7	La Brucherie Rd & Worthington Rd	AWSC	AM	19.9	C	21.1	C	1.2	No
			PM	10.6	B	11.0	B	0.4	No
8	Imperial Ave & Aten Rd	Signal	AM	31.4	C	33.9	C	2.5	No
			PM	25.3	C	28.0	C	2.7	No
9	Proj Dwy & Neckel Rd	OWSC	AM	DNE		10.9	B	10.9	No
			PM			10.3	B	10.3	No
10	La Brucherie Rd & Proj Dwy	OWSC	AM	DNE		8.7	A	8.7	No
			PM			8.8	A	8.8	No
11	SFR Proj Dwy & Ralph Rd	OWSC	AM	DNE					
			PM						
12	MFR Proj Dwy & Ralph Rd	OWSC	AM	DNE					
			PM						
13	Retail Proj Dwy & Ralph Rd	OWSC	AM	DNE					
			PM						
14	Imperial Ave & Proj Dwy	OWSC	AM	DNE					
			PM						

Notes:

OWSC: One-Way Stopped Control, TWSC: Two-Way Stopped Control, AWSC: All-Way Stopped Control

1. Delays are reported as the average control delay for the entire intersection at signalized intersections and the worst movement at unsignalized intersections.

2. LOS calculations are based on the methodology outlined in the *Highway Capacity Manual 6th Edition (HCM6)* and performed using Synchro II.

As shown in the table, all intersections, including the project driveway, are expected to operate at LOS C or better during the weekday peak-hours with the addition of the Project traffic. As a result, no additional intersection improvements are required and/or recommended.

7.4 Roadway Segment Analysis

Table 7-2 displays the LOS analysis for the study area roadway segments under the Opening Year 2024 with and without the Phase 2 Project traffic.

Table 7-2
Opening Year 2024 Roadway LOS Summary

Roadway Segment	Opening Year 2024			Opening Year 2024 w/Phases 1 & 2 Proj			Δ in V/C	Improvement?
	ADT	v/c Ratio	LOS	ADT	v/c Ratio	LOS		
SR-86								
North of Keystone Rd	15,506	0.42	B	16,008	0.43	B	0.014	No
Keystone Rd to Larsen Rd	14,802	0.40	B	15,304	0.41	B	0.014	No
Larsen Rd to Ralph Rd	14,222	0.38	A	14,724	0.40	A	0.014	No
Imperial Ave								
Ralph Rd to Neckel Rd	14,646	0.40	A	15,148	0.41	B	0.013	No
Neckel Rd to Worthington Rd	18,907	0.51	B	20,665	0.56	B	0.048	No
Worthington Rd to Aten Rd	20,825	0.56	B	22,333	0.60	B	0.041	No
South of Aten Rd	22,240	0.60	B	23,244	0.63	B	0.027	No

As shown in the table, all roadway segments would continue to function at LOS B or better with the addition of the Phases 1 and 2 Project traffic. As a result, no additional improvements are required and/or recommended.

8 OPENING YEAR 2026

This section summarizes the operations at the study area intersections, roadway segments, and project driveways with the addition of the Phase 3 project traffic in the anticipated year of opening in 2026.

8.1 Roadway Network

Under this scenario, Ralph Road is assumed to be constructed and extended to the west from Imperial Avenue until La Brucherie Road. The Imperial Avenue & Ralph Road intersection will be upgraded to include a traffic signal. The Project will construct a westbound left-turn lane along Ralph Road for entering traffic to access the multi-family and commercial/retail uses. Additionally, a southbound right-turn deceleration lane will be constructed at the new driveway along Imperial Avenue. **Figure 8-1** illustrates the intersection geometrics with the addition of the Phase 3 Project traffic.

8.2 Traffic Volumes

The Opening Year 2026 Baseline Conditions traffic volumes were developed by applying the annual 1.4 percent regional growth factor and including the cumulative traffic volumes. This growth rate was applied to the existing traffic volumes for five years to estimate the Year 2026 baseline conditions.

Figure 8-2 illustrates the Opening Year 2026 Baseline traffic volumes. **Figure 8-3** illustrates the Opening Year 2026 Plus Phases 1 to 3 Project traffic volumes.

8.3 Intersection Analysis

Table 8-1 displays the LOS analysis results for the study intersections and project driveways under Opening Year 2026 Baseline and Plus Phases 1 to 3 Project conditions.

Appendix C contains the intersection LOS worksheets.

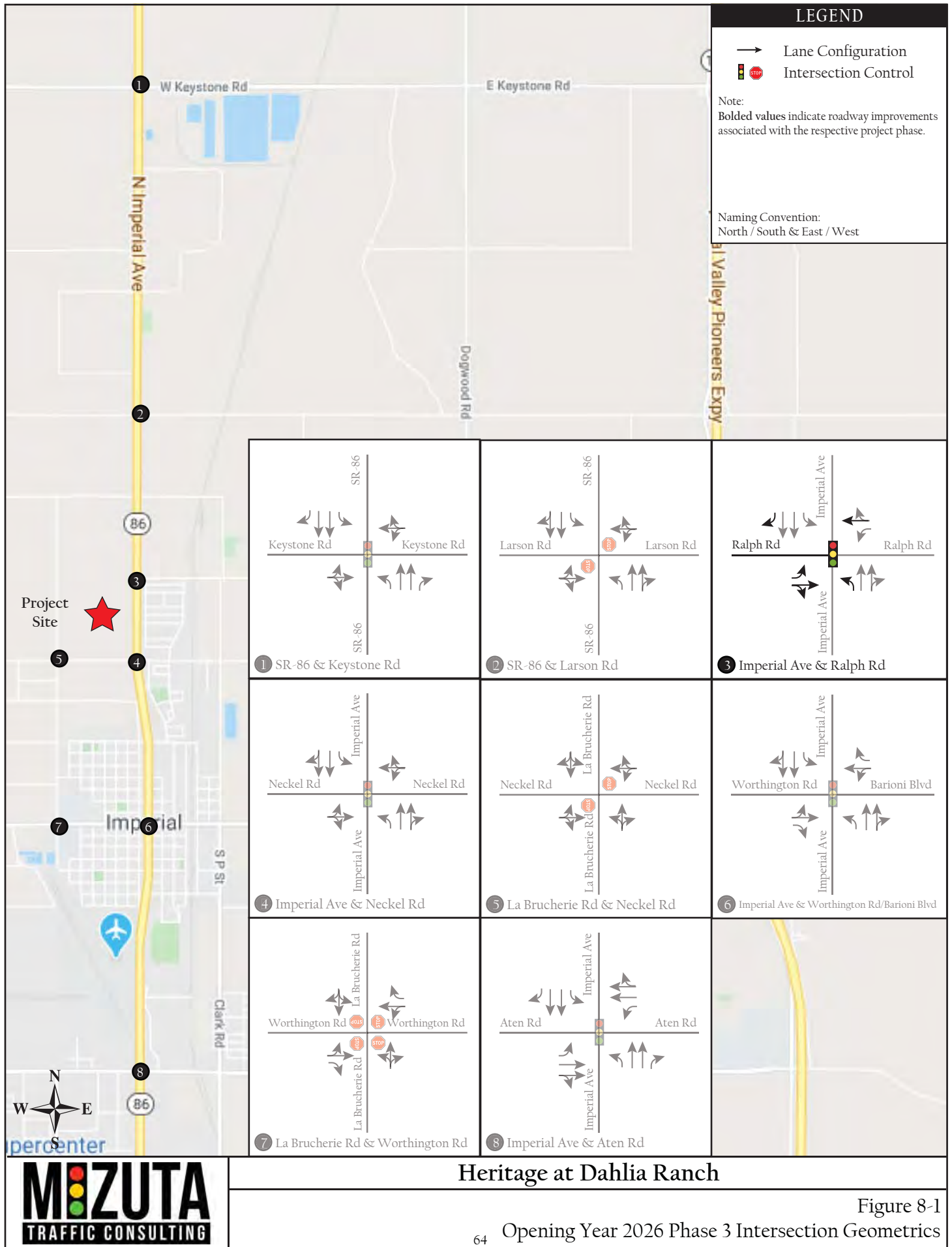

LEGEND

- Lane Configuration
- STOP Intersection Control

Naming Convention:
North / South & East / West

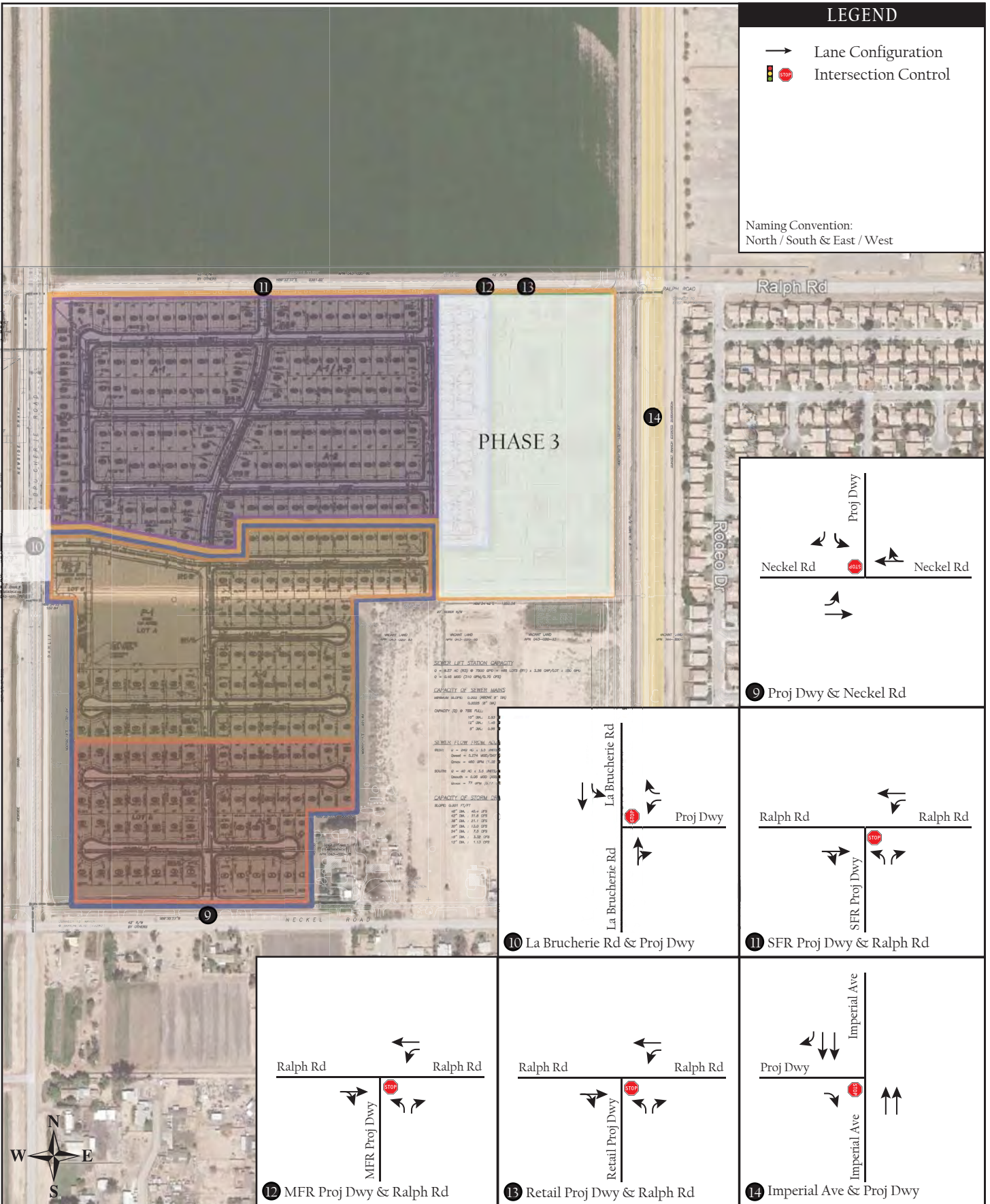

Heritage at Dahlia Ranch

Figure 8-1a

Opening Year 2026 Phase 3 Intersection Geometrics

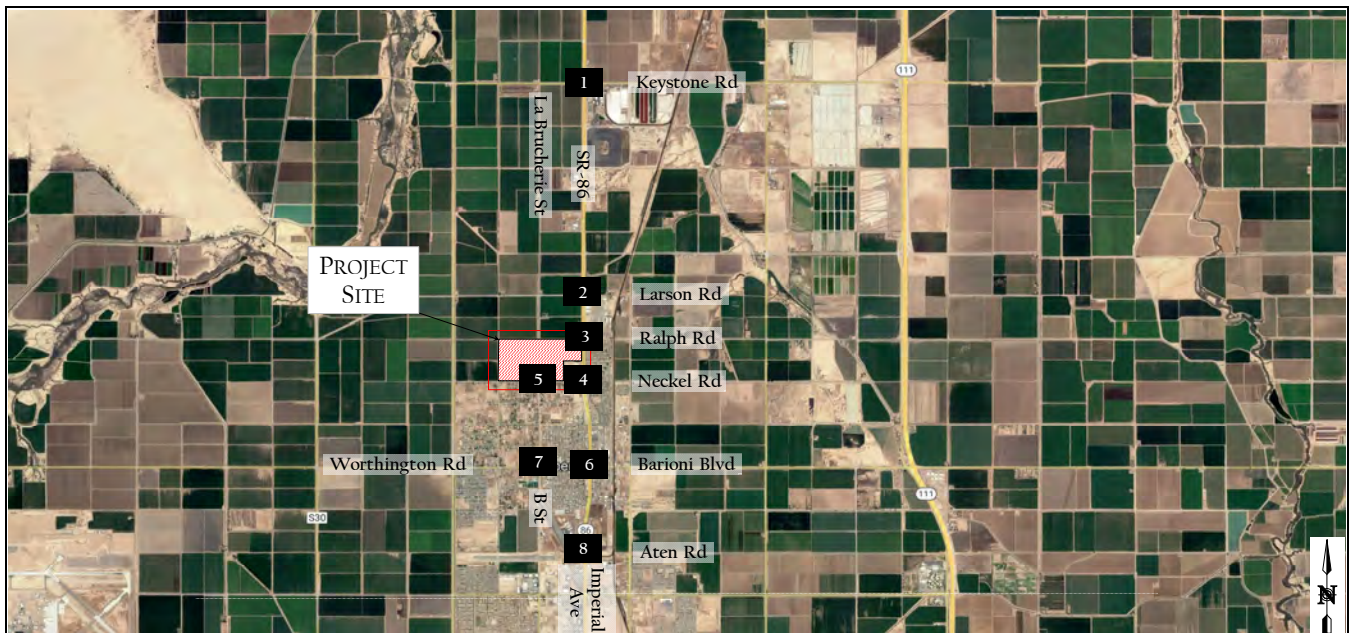

xx / yy - AM / PM Peak-Hour Turning Movement Volumes
 The naming convention for intersections is North / South & East / West

SR-86 & Keystone Rd		SR-86 & Larsen Rd		Imperial Ave & Ralph Rd		Imperial Ave & Neckel Rd																																	
39 / 35 ↘ ↙ 543 / 395 ↔ 47 / 55 ↗ ↖ 44 / 39 ↘ ↙ 25 / 28 ↔ 19 / 34 ↗ ↖	1	8 / 18 ↘ ↙ 548 / 632 ↔ 1 / 6 ↗ ↖ 5 / 5 ↘ ↙ 2 / 0 ↔ 1 / 8 ↗ ↖	2	330 / 395 ↘ ↙ 20 / 31 ↔ 24 / 11 ↗ ↖ 61 / 20	3	32 / 29 ↘ ↙ 533 / 517 ↔ 24 / 60 ↗ ↖ 85 / 66 ↘ ↙ 66 / 20 ↔ 228 / 139 ↗ ↖	4	34 / 43 ↘ ↙ 34 / 13 ↔ 12 / 20 ↗ ↖ 19 / 11 ↘ ↙ 485 / 564 ↔ 51 / 27 ↗ ↖	5	20 / 6 ↘ ↙ 3 / 4 ↔ 2 / 0 ↗ ↖ 0 / 1 ↘ ↙ 554 / 603 ↔ 1 / 8 ↗ ↖	6	532 / 604 ↘ ↙ 43 / 31 ↔	7	35 / 13 ↘ ↙ 45 / 27 ↔ 13 / 4 ↗ ↖ 9 / 12 ↘ ↙ 461 / 579 ↔ 95 / 178 ↗ ↖	8	La Brucherie Rd & Neckel Rd		Imperial Ave & Barioni Blvd / Worthington Rd		B St / La Brucherie Rd & Worthington Rd		Imperial Ave & Aten Rd		1 / 8 ↘ ↙ 2 / 5 ↔ 1 / 0 ↗ ↖ 0 / 1 ↘ ↙ 46 / 46 ↔ 62 / 24 ↗ ↖	5	71 / 74 ↘ ↙ 724 / 663 ↔ 41 / 28 ↗ ↖ 80 / 54 ↘ ↙ 137 / 117 ↔ 57 / 57 ↗ ↖	6	66 / 25 ↘ ↙ 32 / 5 ↔ 110 / 39 ↗ ↖ 80 / 35 ↘ ↙ 327 / 233 ↔ 12 / 28 ↗ ↖	7	404 / 227 ↘ ↙ 753 / 596 ↔ 148 / 117 ↗ ↖ 147 / 128 ↘ ↙ 312 / 300 ↔ 136 / 185 ↗ ↖	8	4 / 2 ↘ ↙ 43 / 40 ↔ 24 / 9 ↗ ↖ 8 / 5 ↘ ↙ 6 / 6 ↔ 44 / 11 ↗ ↖	5	78 / 65 ↘ ↙ 142 / 77 ↔ 221 / 109 ↗ ↖ 96 / 117 ↘ ↙ 508 / 771 ↔ 53 / 15 ↗ ↖	6	63 / 27 ↘ ↙ 411 / 210 ↔ 124 / 34 ↗ ↖ 0 / 1 ↘ ↙ 1 / 0 ↗ ↖	7	199 / 212 ↘ ↙ 352 / 287 ↔ 65 / 71 ↗ ↖ 63 / 81 ↘ ↙ 376 / 753 ↔ 70 / 155 ↗ ↖	8
34 / 43 ↘ ↙ 34 / 13 ↔ 12 / 20 ↗ ↖ 19 / 11 ↘ ↙ 485 / 564 ↔ 51 / 27 ↗ ↖	5	20 / 6 ↘ ↙ 3 / 4 ↔ 2 / 0 ↗ ↖ 0 / 1 ↘ ↙ 554 / 603 ↔ 1 / 8 ↗ ↖	6	532 / 604 ↘ ↙ 43 / 31 ↔	7	35 / 13 ↘ ↙ 45 / 27 ↔ 13 / 4 ↗ ↖ 9 / 12 ↘ ↙ 461 / 579 ↔ 95 / 178 ↗ ↖	8	La Brucherie Rd & Neckel Rd		Imperial Ave & Barioni Blvd / Worthington Rd		B St / La Brucherie Rd & Worthington Rd		Imperial Ave & Aten Rd		1 / 8 ↘ ↙ 2 / 5 ↔ 1 / 0 ↗ ↖ 0 / 1 ↘ ↙ 46 / 46 ↔ 62 / 24 ↗ ↖	5	71 / 74 ↘ ↙ 724 / 663 ↔ 41 / 28 ↗ ↖ 80 / 54 ↘ ↙ 137 / 117 ↔ 57 / 57 ↗ ↖	6	66 / 25 ↘ ↙ 32 / 5 ↔ 110 / 39 ↗ ↖ 80 / 35 ↘ ↙ 327 / 233 ↔ 12 / 28 ↗ ↖	7	404 / 227 ↘ ↙ 753 / 596 ↔ 148 / 117 ↗ ↖ 147 / 128 ↘ ↙ 312 / 300 ↔ 136 / 185 ↗ ↖	8	4 / 2 ↘ ↙ 43 / 40 ↔ 24 / 9 ↗ ↖ 8 / 5 ↘ ↙ 6 / 6 ↔ 44 / 11 ↗ ↖	5	78 / 65 ↘ ↙ 142 / 77 ↔ 221 / 109 ↗ ↖ 96 / 117 ↘ ↙ 508 / 771 ↔ 53 / 15 ↗ ↖	6	63 / 27 ↘ ↙ 411 / 210 ↔ 124 / 34 ↗ ↖ 0 / 1 ↘ ↙ 1 / 0 ↗ ↖	7	199 / 212 ↘ ↙ 352 / 287 ↔ 65 / 71 ↗ ↖ 63 / 81 ↘ ↙ 376 / 753 ↔ 70 / 155 ↗ ↖	8								
La Brucherie Rd & Neckel Rd		Imperial Ave & Barioni Blvd / Worthington Rd		B St / La Brucherie Rd & Worthington Rd		Imperial Ave & Aten Rd																																	
1 / 8 ↘ ↙ 2 / 5 ↔ 1 / 0 ↗ ↖ 0 / 1 ↘ ↙ 46 / 46 ↔ 62 / 24 ↗ ↖	5	71 / 74 ↘ ↙ 724 / 663 ↔ 41 / 28 ↗ ↖ 80 / 54 ↘ ↙ 137 / 117 ↔ 57 / 57 ↗ ↖	6	66 / 25 ↘ ↙ 32 / 5 ↔ 110 / 39 ↗ ↖ 80 / 35 ↘ ↙ 327 / 233 ↔ 12 / 28 ↗ ↖	7	404 / 227 ↘ ↙ 753 / 596 ↔ 148 / 117 ↗ ↖ 147 / 128 ↘ ↙ 312 / 300 ↔ 136 / 185 ↗ ↖	8	4 / 2 ↘ ↙ 43 / 40 ↔ 24 / 9 ↗ ↖ 8 / 5 ↘ ↙ 6 / 6 ↔ 44 / 11 ↗ ↖	5	78 / 65 ↘ ↙ 142 / 77 ↔ 221 / 109 ↗ ↖ 96 / 117 ↘ ↙ 508 / 771 ↔ 53 / 15 ↗ ↖	6	63 / 27 ↘ ↙ 411 / 210 ↔ 124 / 34 ↗ ↖ 0 / 1 ↘ ↙ 1 / 0 ↗ ↖	7	199 / 212 ↘ ↙ 352 / 287 ↔ 65 / 71 ↗ ↖ 63 / 81 ↘ ↙ 376 / 753 ↔ 70 / 155 ↗ ↖	8																								
4 / 2 ↘ ↙ 43 / 40 ↔ 24 / 9 ↗ ↖ 8 / 5 ↘ ↙ 6 / 6 ↔ 44 / 11 ↗ ↖	5	78 / 65 ↘ ↙ 142 / 77 ↔ 221 / 109 ↗ ↖ 96 / 117 ↘ ↙ 508 / 771 ↔ 53 / 15 ↗ ↖	6	63 / 27 ↘ ↙ 411 / 210 ↔ 124 / 34 ↗ ↖ 0 / 1 ↘ ↙ 1 / 0 ↗ ↖	7	199 / 212 ↘ ↙ 352 / 287 ↔ 65 / 71 ↗ ↖ 63 / 81 ↘ ↙ 376 / 753 ↔ 70 / 155 ↗ ↖	8																																

	<p>Heritage at Dahlia Ranch</p> <p>Opening Year 2026 Baseline Traffic Volumes</p>	<p>Figure 8-2</p>
--	---	-------------------

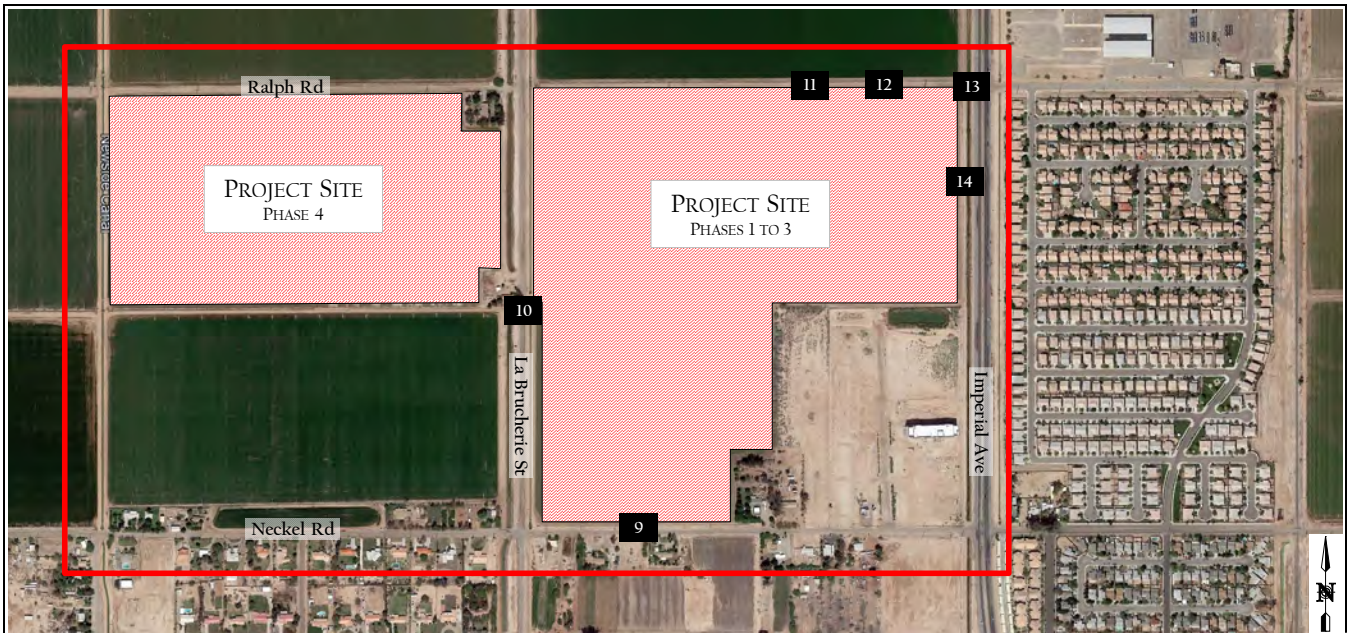

xx / yy - AM / PM Peak-Hour Turning Movement Volumes
 The naming convention for intersections is North / South & East / West

Proj Dwy & Neckel Rd	La Brucherie Rd & Proj Dwy	SFR Proj Dwy & Ralph Rd	MFR Proj Dwy & Ralph Rd
Does not exist	Does not exist	Does not exist	Does not exist
Retail Proj Dwy & Ralph Rd	Imperial Ave & Proj Dwy		
Does not exist	Does not exist		



Heritage at Dahlia Ranch
 Opening Year 2026 Baseline Traffic Volumes

Figure 8-2a

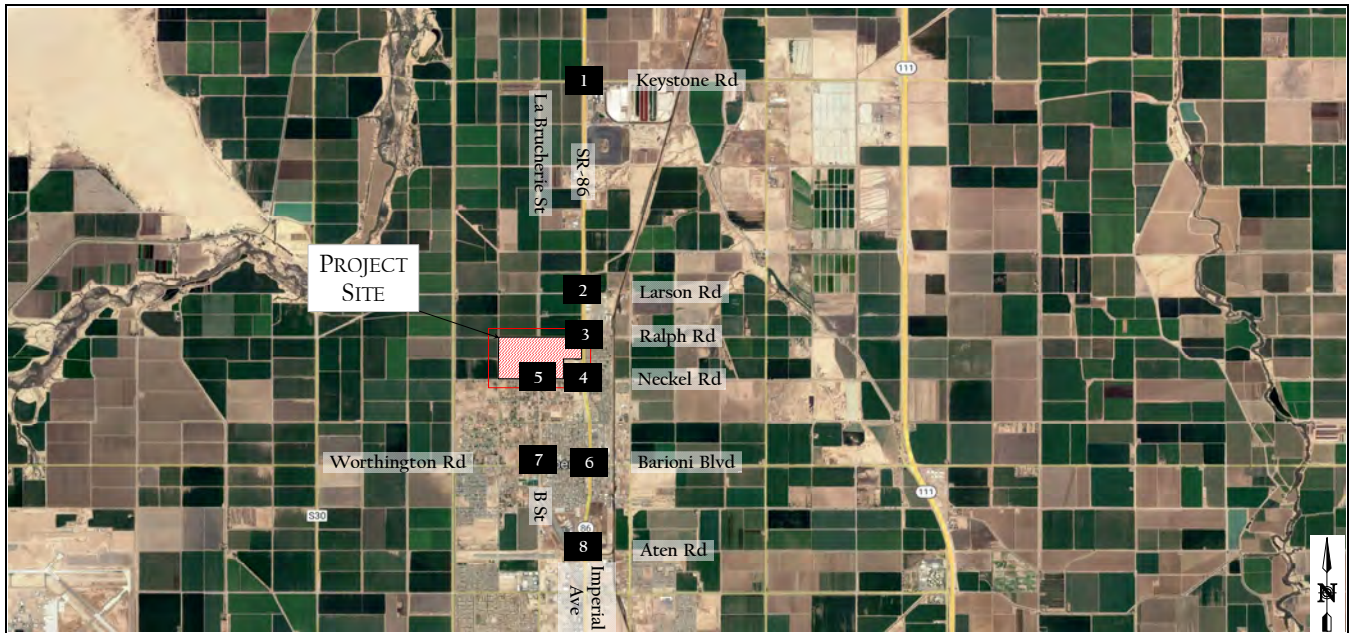

xx / yy - AM / PM Peak-Hour Turning Movement Volumes
 The naming convention for intersections is North / South & East / West

SR-86 & Keystone Rd		SR-86 & Larsen Rd		Imperial Ave & Ralph Rd		Imperial Ave & Neckel Rd									
39 / 35 ↘ ↙ 591 / 672 ↔ 47 / 55 ↗ ↖ 44 / 39 ↘ ↙ 25 / 28 ↔ 19 / 34 ↗ ↖	1	8 / 18 ↘ ↙ 596 / 709 ↔ 1 / 6 ↗ ↖ 5 / 5 ↘ ↙ 2 / 0 ↔ 1 / 8 ↗ ↖	2	31 / 59 ↘ ↙ 547 / 613 ↔ 20 / 31 ↗ ↖ 24 / 11 ↘ ↙ 17 / 18 ↔ 61 / 20 ↗ ↖	3	32 / 29 ↘ ↙ 671 / 672 ↔ 35 / 82 ↗ ↖ 102 / 84 ↘ ↙ 66 / 20 ↔ 228 / 139 ↗ ↖	4	34 / 43 ↘ ↙ 34 / 13 ↔ 12 / 20 ↗ ↖ 19 / 11 ↘ ↙ 545 / 630 ↔ 51 / 27 ↗ ↖	5	20 / 6 ↘ ↙ 3 / 4 ↔ 2 / 0 ↗ ↖ 0 / 1 ↘ ↙ 614 / 669 ↔ 1 / 8 ↗ ↖	6	60 / 66 ↘ ↙ 11 / 22 ↔ 106 / 90 ↗ ↖ 134 / 192 ↘ ↙ 532 / 604 ↔ 43 / 31 ↗ ↖	7	35 / 13 ↘ ↙ 45 / 27 ↔ 65 / 38 ↗ ↖ 27 / 71 ↘ ↙ 578 / 754 ↔ 95 / 178 ↗ ↖	8
34 / 43 ↘ ↙ 34 / 13 ↔ 12 / 20 ↗ ↖ 19 / 11 ↘ ↙ 545 / 630 ↔ 51 / 27 ↗ ↖	5	20 / 6 ↘ ↙ 3 / 4 ↔ 2 / 0 ↗ ↖ 0 / 1 ↘ ↙ 614 / 669 ↔ 1 / 8 ↗ ↖	6	60 / 66 ↘ ↙ 11 / 22 ↔ 106 / 90 ↗ ↖ 134 / 192 ↘ ↙ 532 / 604 ↔ 43 / 31 ↗ ↖	7	35 / 13 ↘ ↙ 45 / 27 ↔ 65 / 38 ↗ ↖ 27 / 71 ↘ ↙ 578 / 754 ↔ 95 / 178 ↗ ↖	8								

La Brucherie Rd & Neckel Rd		Imperial Ave & Barioni Blvd / Worthington Rd		B St / La Brucherie Rd & Worthington Rd		Imperial Ave & Aten Rd									
1 / 8 ↘ ↙ 25 / 34 ↔ 77 / 94 ↗ ↖ 67 / 105 ↘ ↙ 46 / 46 ↔ 69 / 29 ↗ ↖	5	71 / 74 ↘ ↙ 883 / 818 ↔ 72 / 62 ↗ ↖ 104 / 93 ↘ ↙ 137 / 117 ↔ 57 / 57 ↗ ↖	6	97 / 59 ↘ ↙ 32 / 5 ↔ 110 / 39 ↗ ↖ 80 / 35 ↘ ↙ 327 / 233 ↔ 12 / 28 ↗ ↖	7	435 / 261 ↘ ↙ 852 / 685 ↔ 179 / 151 ↗ ↖ 171 / 167 ↘ ↙ 312 / 300 ↔ 136 / 185 ↗ ↖	8	4 / 2 ↘ ↙ 43 / 40 ↔ 24 / 9 ↗ ↖ 8 / 5 ↘ ↙ 28 / 36 ↔ 47 / 19 ↗ ↖	5	78 / 65 ↘ ↙ 142 / 77 ↔ 221 / 109 ↗ ↖ 96 / 117 ↘ ↙ 618 / 966 ↔ 53 / 15 ↗ ↖	6	87 / 66 ↘ ↙ 411 / 210 ↔ 124 / 34 ↗ ↖ 0 / 1 ↘ ↙ 1 / 0 ↗ ↖	7	223 / 251 ↘ ↙ 352 / 287 ↔ 65 / 71 ↗ ↖ 63 / 81 ↘ ↙ 437 / 871 ↔ 70 / 155 ↗ ↖	8
4 / 2 ↘ ↙ 43 / 40 ↔ 24 / 9 ↗ ↖ 8 / 5 ↘ ↙ 28 / 36 ↔ 47 / 19 ↗ ↖	5	78 / 65 ↘ ↙ 142 / 77 ↔ 221 / 109 ↗ ↖ 96 / 117 ↘ ↙ 618 / 966 ↔ 53 / 15 ↗ ↖	6	87 / 66 ↘ ↙ 411 / 210 ↔ 124 / 34 ↗ ↖ 0 / 1 ↘ ↙ 1 / 0 ↗ ↖	7	223 / 251 ↘ ↙ 352 / 287 ↔ 65 / 71 ↗ ↖ 63 / 81 ↘ ↙ 437 / 871 ↔ 70 / 155 ↗ ↖	8								

	<p>Heritage at Dahlia Ranch</p> <p>Opening Year 2026 Plus Phases 1 to 3 Project Traffic Volumes</p>	<p>Figure 8-3</p>
--	---	-------------------

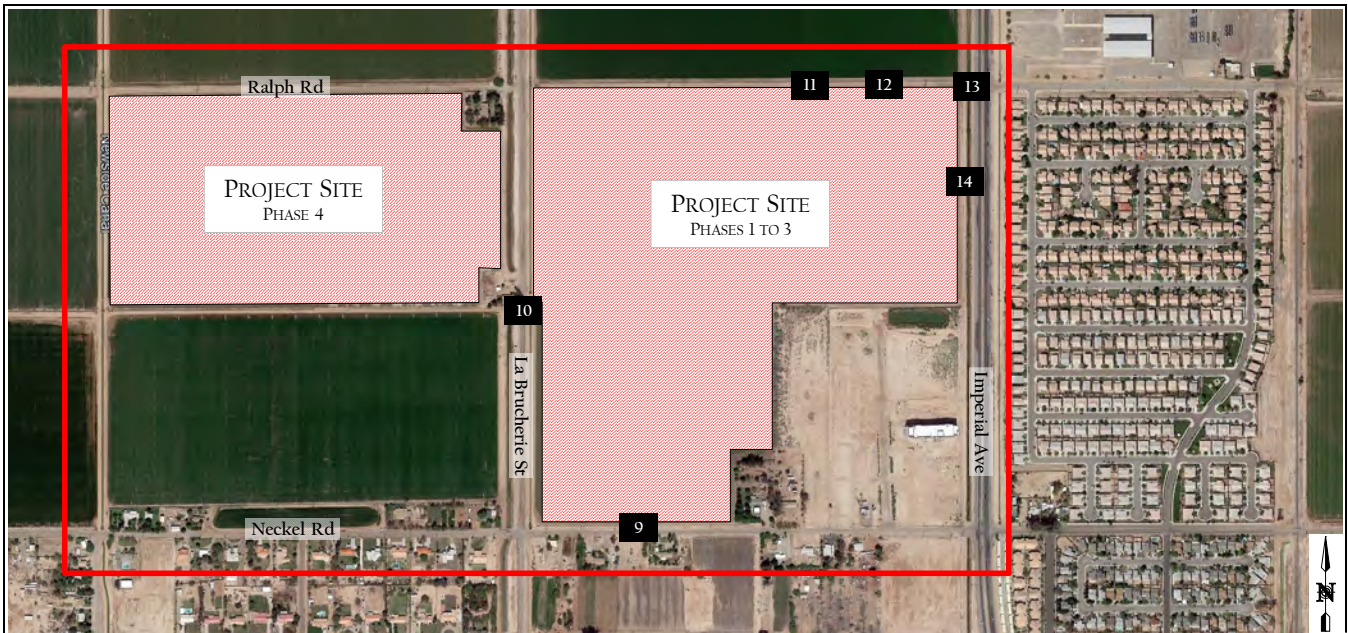

xx / yy - AM / PM Peak-Hour Turning Movement Volumes
 The naming convention for intersections is North / South & East / West

Proj Dwy & Neckel Rd	La Brucherie Rd & Proj Dwy	SFR Proj Dwy & Ralph Rd	MFR Proj Dwy & Ralph Rd
<p>7 / 5</p> <p>52 / 34</p> <p>18 / 59</p> <p>107 / 61</p> <p>9</p> <p>3 / 8</p> <p>93 / 44</p>	<p>32 / 51</p> <p>10</p> <p>7 / 5</p> <p>43 / 48</p> <p>3 / 8</p>	<p>28 / 38</p> <p>28 / 92</p> <p>11</p> <p>32 / 38</p> <p>81 / 53</p>	<p>51 / 128</p> <p>16 / 33</p> <p>12</p> <p>111 / 87</p> <p>2 / 4</p> <p>5 / 2</p> <p>42 / 17</p>
Retail Proj Dwy & Ralph Rd	Imperial Ave & Proj Dwy		
<p>44 / 125</p> <p>242 / 270</p> <p>13</p> <p>123 / 70</p> <p>30 / 34</p> <p>23 / 36</p> <p>116 / 180</p>	<p>30 / 34</p> <p>713 / 704</p> <p>14</p> <p>92 / 144</p> <p>760 / 904</p>		



Heritage at Dahlia Ranch
 Opening Year 2026 Plus Phases 1 to 3 Project Traffic Volumes

Figure 8-3a

**Table 8-1
Opening Year 2026 Peak Hour Intersection LOS Summary**

#	Intersection	Traffic Control	Peak Hour	Opening Year 2026		Opening Year 2026 w/Phases 1 to 3 Proj		Δ in Delay	Improvement?
				Delay ¹	LOS ²	Delay ¹	LOS ²		
1	SR-86 & Keystone Rd	Signal	AM	9.4	A	9.4	A	0.0	No
			PM	9.4	A	9.4	A	0.0	No
2	SR-86 & Larson Rd	TWSC	AM	15.8	C	16.8	C	1.0	No
			PM	18.2	C	20.0	C	1.8	No
3	Imperial Ave & Ralph Rd	Signal	AM	21.5	C	18.0	B	-3.5	No
			PM	20.1	C	22.4	C	2.3	No
4	Imperial Ave & Neckel Rd	Signal	AM	23.1	C	34.0	C	10.9	No
			PM	18.8	B	28.0	C	9.2	No
5	La Brucherie Rd & Neckel Rd	TWSC	AM	10.3	B	13.8	B	3.5	No
			PM	9.7	A	12.4	B	2.7	No
6	Imperial Ave & Worthington Rd/Barioni Blvd	Signal	AM	33.8	C	51.2	D	17.4	No
			PM	25.2	C	35.3	D	10.1	No
7	La Brucherie Rd & Worthington Rd	AWSC	AM	22.5	C	27.7	D	5.2	No
			PM	11.1	B	12.2	B	1.1	No
8	Imperial Ave & Aten Rd	Signal	AM	35.2	D	40.2	D	5.0	No
			PM	28.1	C	37.9	D	9.8	No
9	Proj Dwy & Neckel Rd	OWSC	AM	DNE		10.0	A	10.0	No
			PM	DNE		9.5	A	9.5	No
10	La Brucherie Rd & Proj Dwy	OWSC	AM	DNE		9.0	A	9.0	No
			PM	DNE		9.1	A	9.1	No
11	SFR Proj Dwy & Ralph Rd	OWSC	AM	DNE		8.8	A	8.8	No
			PM	DNE		8.7	A	8.7	No
12	MFR Proj Dwy & Ralph Rd	OWSC	AM	DNE		9.2	A	9.2	No
			PM	DNE		9.0	A	9.0	No
13	Retail Proj Dwy & Ralph Rd	OWSC	AM	DNE		10.9	B	10.9	No
			PM	DNE		11.4	B	11.4	No
14	Imperial Ave & Proj Dwy	OWSC	AM	DNE		12.0	B	12.0	No
			PM	DNE		12.8	B	12.8	No

Notes:

OWSC: One-Way Stopped Control, TWSC: Two-Way Stopped Control, AWSC: All-Way Stopped Control

1. Delays are reported as the average control delay for the entire intersection at signalized intersections and the worst movement at unsignalized intersections.

2. LOS calculations are based on the methodology outlined in the *Highway Capacity Manual 6th Edition (HCM6)* and performed using Synchro II.

As shown in the table, all intersections, including the project driveways, are expected to operate at LOS D or better during the weekday peak-hours with the addition of the Project traffic. As a result, no additional intersection improvements are required and/or recommended.

8.4 Roadway Segment Analysis

Table 8-2 displays the LOS analysis for the study area roadway segments under the Opening Year 2026 with and without the Phase 3 Project traffic.

Table 8-2
Opening Year 2026 Roadway LOS Summary

Roadway Segment	Opening Year 2026			Opening Year 2026 w/Phases 1 to 3 Proj			Δ in V/C	Improvement?
	ADT	v/c Ratio	LOS	ADT	v/c Ratio	LOS		
SR-86								
North of Keystone Rd	16,378	0.44	B	18,102	0.49	B	0.046	No
Keystone Rd to Larsen Rd	15,654	0.42	B	17,378	0.47	B	0.047	No
Larsen Rd to Ralph Rd	15,059	0.41	B	16,783	0.45	B	0.047	No
Imperial Ave								
Ralph Rd to Neckel Rd	15,495	0.42	B	20,300	0.55	B	0.130	No
Neckel Rd to Worthington Rd	20,781	0.56	B	25,173	0.68	C	0.118	No
Worthington Rd to Aten Rd	22,523	0.61	B	26,493	0.72	C	0.107	No
South of Aten Rd	23,748	0.64	B	25,992	0.70	C	0.060	No

As shown in the table, all roadway segments would continue to function at LOS C or better with the addition of the project traffic. As a result, no additional improvements are required and/or recommended.

9 OPENING YEAR 2028

This section summarizes the operations at the study area intersections, roadway segments, and project driveways with the addition of the Phase 4 project traffic in the anticipated year of opening in 2028.

9.1 Roadway Network

No changes to the existing roadway network are proposed under this condition except for the construction of the west leg of the La Brucherie Road & Project Driveway intersection. **Figure 9-1** illustrates the intersection geometrics with the addition of the Phase 4 Project traffic.

9.2 Traffic Volumes

The Opening Year 2028 Baseline Conditions traffic volumes were developed by applying the annual 1.4 percent regional growth factor and including the cumulative traffic volumes. This growth rate was applied to the existing traffic volumes for seven years to estimate the Year 2028 baseline conditions.

Figure 9-2 illustrates the Opening Year 2028 Baseline traffic volumes. **Figure 9-3** illustrates the Opening Year 2028 Plus Phases 1 to 4 Project traffic volumes.

9.3 Intersection Analysis

Table 9-1 displays the LOS analysis results for the study intersections and project driveways under Opening Year 2028 Baseline and Plus Phases 1 to 4 Project conditions.

Appendix C contains the intersection LOS worksheets.

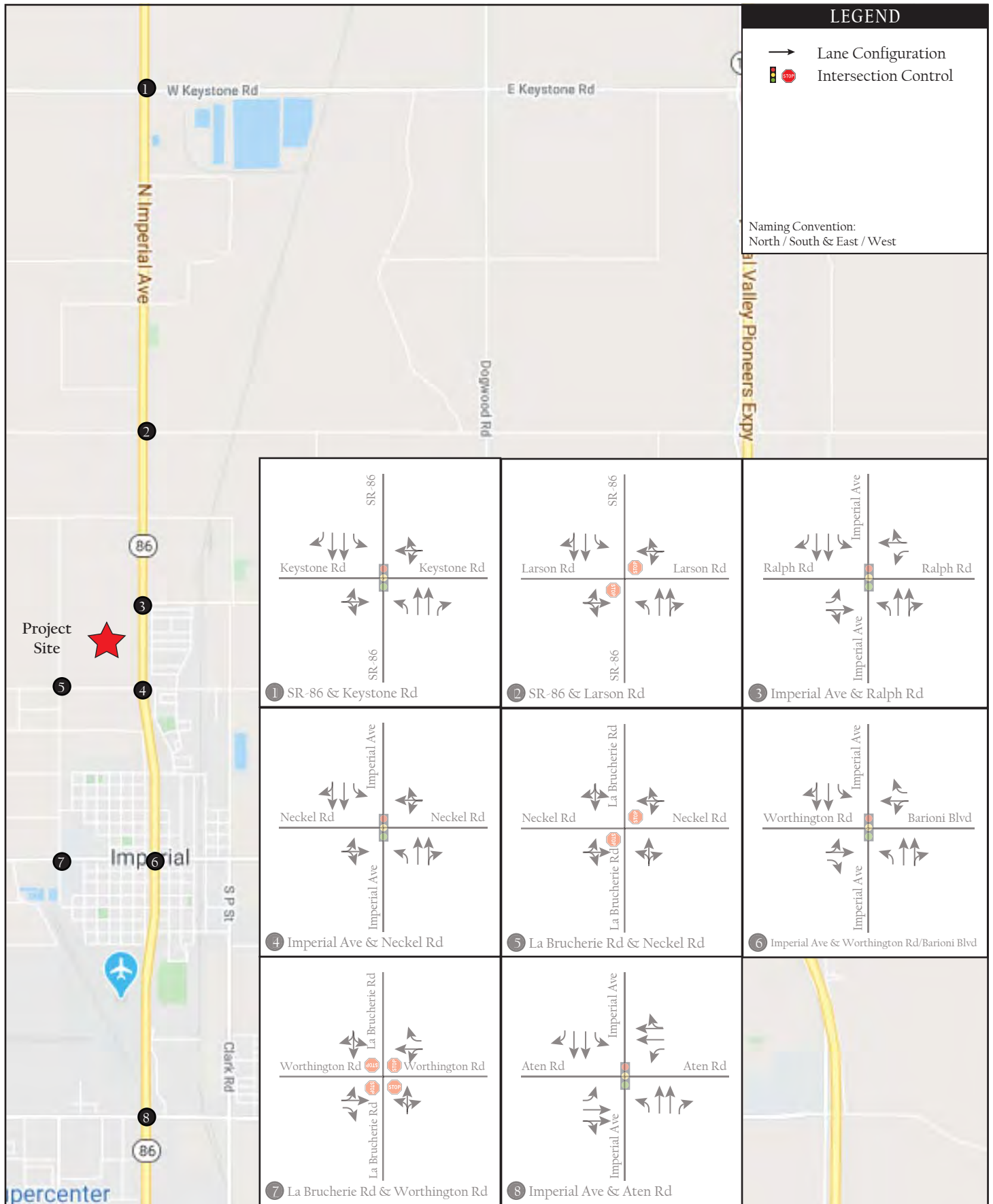

Heritage at Dahlia Ranch

Figure 9-1

73 Opening Year 2028 Phase 4 Intersection Geometrics

LEGEND

- Lane Configuration
- Intersection Control

Note:
Bolded values indicate roadway improvements associated with the respective project phase.

Naming Convention:
 North / South & East / West

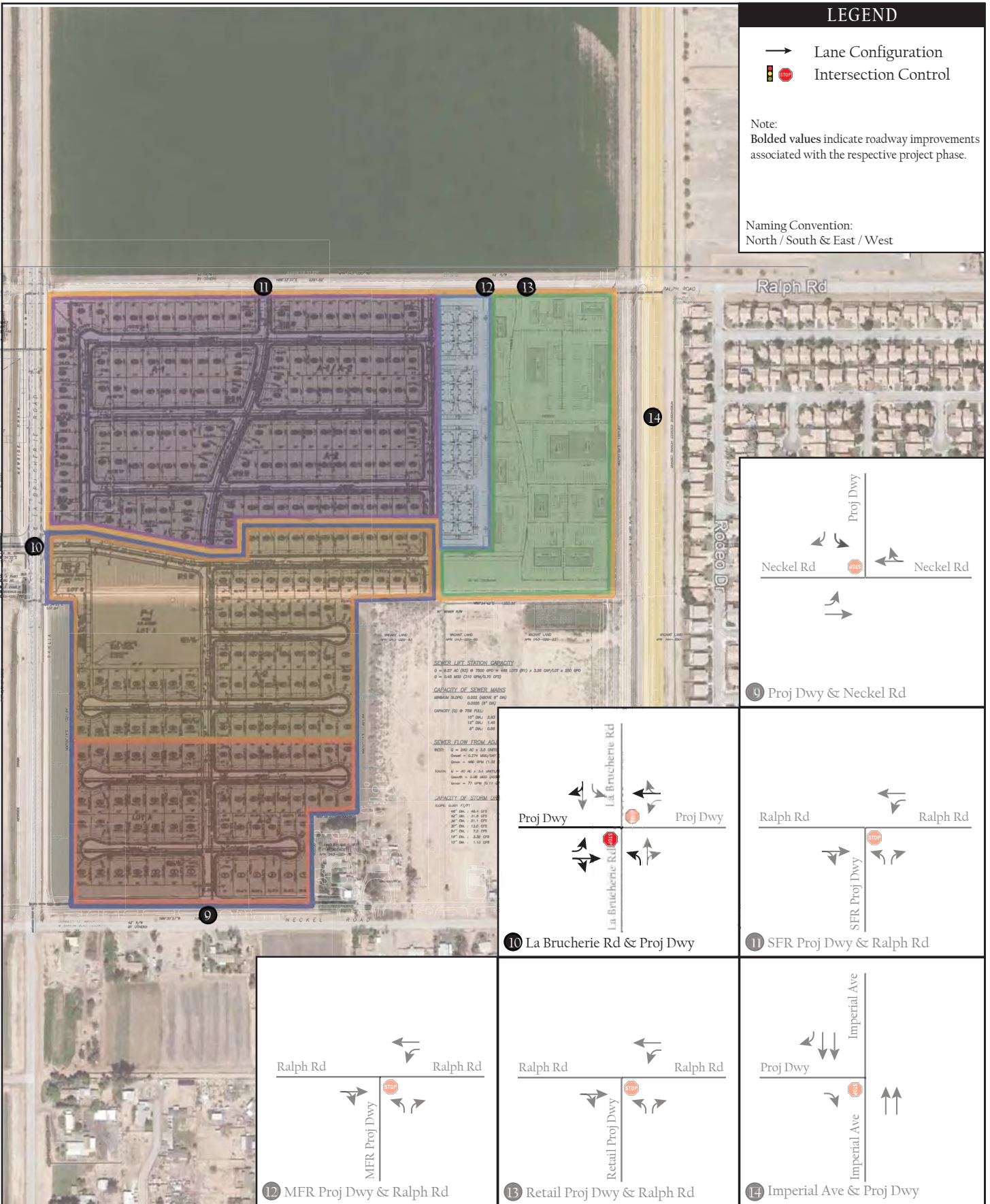

Heritage at Dahlia Ranch

Figure 9-1a

Opening Year 2028 Phase 4 Intersection Geometrics

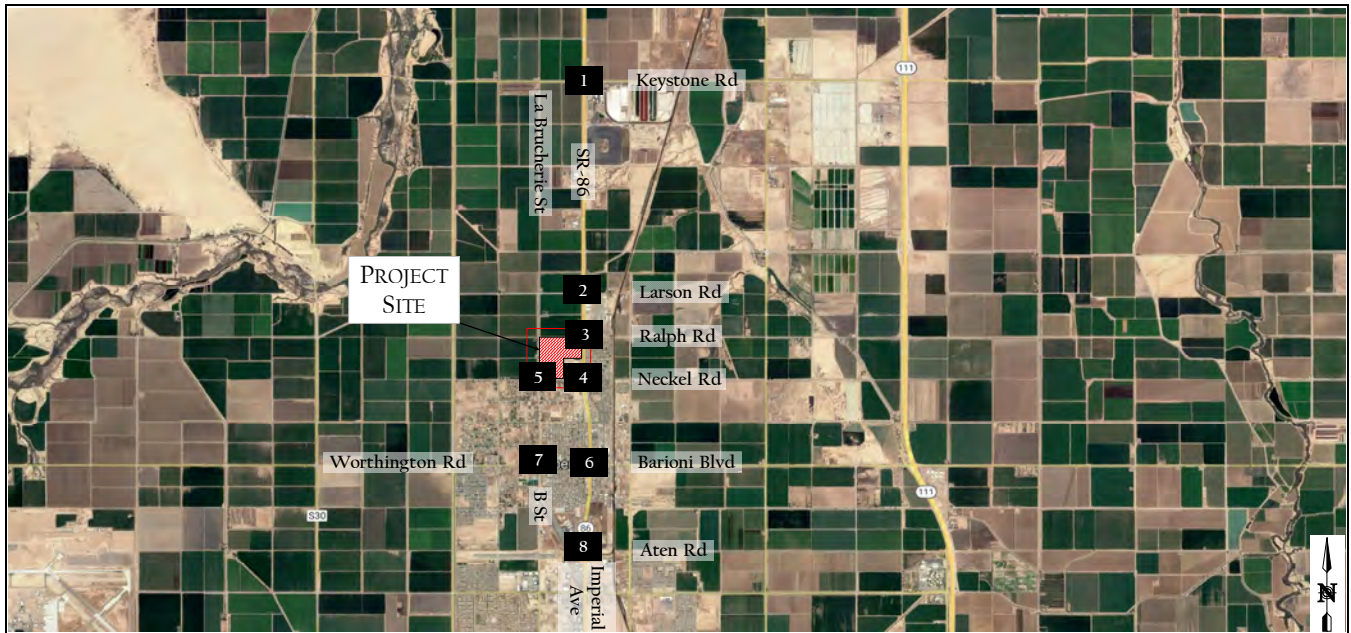

xx / yy - AM / PM Peak-Hour Turning Movement Volumes
 The naming convention for intersections is North / South & East / West

SR-86 & Keystone Rd		SR-86 & Larsen Rd		Imperial Ave & Ralph Rd		Imperial Ave & Neckel Rd	
40 / 36 ↙ ↘ 564 / 632 ↔ 48 / 56 ↙ ↘	45 / 40 ↙ ↘ 25 / 29 ↔ 20 / 35 ↙ ↘	8 / 19 ↙ ↘ 569 / 670 ↔ 1 / 7 ↙ ↘	6 / 6 ↙ ↘ 2 / 0 ↔ 1 / 8 ↙ ↘	545 / 611 ↙ ↘ 27 / 53 ↔	45 / 23 ↙ ↘ 127 / 58 ↔	33 / 30 ↙ ↘ 612 / 568 ↔ 24 / 61 ↙ ↘	87 / 68 ↙ ↘ 68 / 21 ↔ 232 / 141 ↙ ↘
35 / 44 ↙ ↘ 35 / 13 ↔ 12 / 21 ↙ ↘	20 / 11 ↙ ↘ 519 / 591 ↔ 53 / 28 ↙ ↘	21 / 7 ↙ ↘ 3 / 4 ↔ 2 / 0 ↙ ↘	0 / 1 ↙ ↘ 632 / 590 ↔ 1 / 8 ↙ ↘	546 / 621 ↙ ↘ 63 / 96 ↔	36 / 13 ↙ ↘ 46 / 28 ↔ 13 / 4 ↙ ↘	9 / 12 ↙ ↘ 493 / 659 ↔ 96 / 180 ↙ ↘	
La Brucherie Rd & Neckel Rd		Imperial Ave & Barioni Blvd / Worthington Rd		B St / La Brucherie Rd & Worthington Rd		Imperial Ave & Aten Rd	
1 / 8 ↙ ↘ 2 / 6 ↔ 1 / 0 ↙ ↘	0 / 1 ↙ ↘ 47 / 47 ↔ 64 / 24 ↙ ↘	84 / 82 ↙ ↘ 796 / 711 ↔ 42 / 29 ↙ ↘	83 / 55 ↙ ↘ 141 / 120 ↔ 58 / 58 ↙ ↘	68 / 25 ↙ ↘ 33 / 6 ↔ 114 / 40 ↙ ↘	83 / 36 ↙ ↘ 347 / 245 ↔ 12 / 29 ↙ ↘	426 / 239 ↙ ↘ 815 / 636 ↔ 152 / 120 ↙ ↘	151 / 131 ↙ ↘ 321 / 309 ↔ 140 / 191 ↙ ↘
4 / 2 ↙ ↘ 44 / 41 ↔ 24 / 9 ↙ ↘	8 / 6 ↙ ↘ 7 / 7 ↔ 45 / 11 ↙ ↘	83 / 78 ↙ ↘ 145 / 79 ↔ 227 / 112 ↙ ↘	99 / 120 ↙ ↘ 537 / 843 ↔ 54 / 15 ↙ ↘	65 / 28 ↙ ↘ 426 / 227 ↔ 128 / 35 ↙ ↘	0 / 1 ↙ ↘ 1 / 0 ↔	208 / 229 ↙ ↘ 362 / 295 ↔ 67 / 73 ↙ ↘	65 / 84 ↙ ↘ 399 / 814 ↔ 72 / 160 ↙ ↘

	<p>Heritage at Dahlia Ranch</p> <p>Opening Year 2028 Baseline Traffic Volumes</p>	<p>Figure 9-2</p>
--	---	-------------------

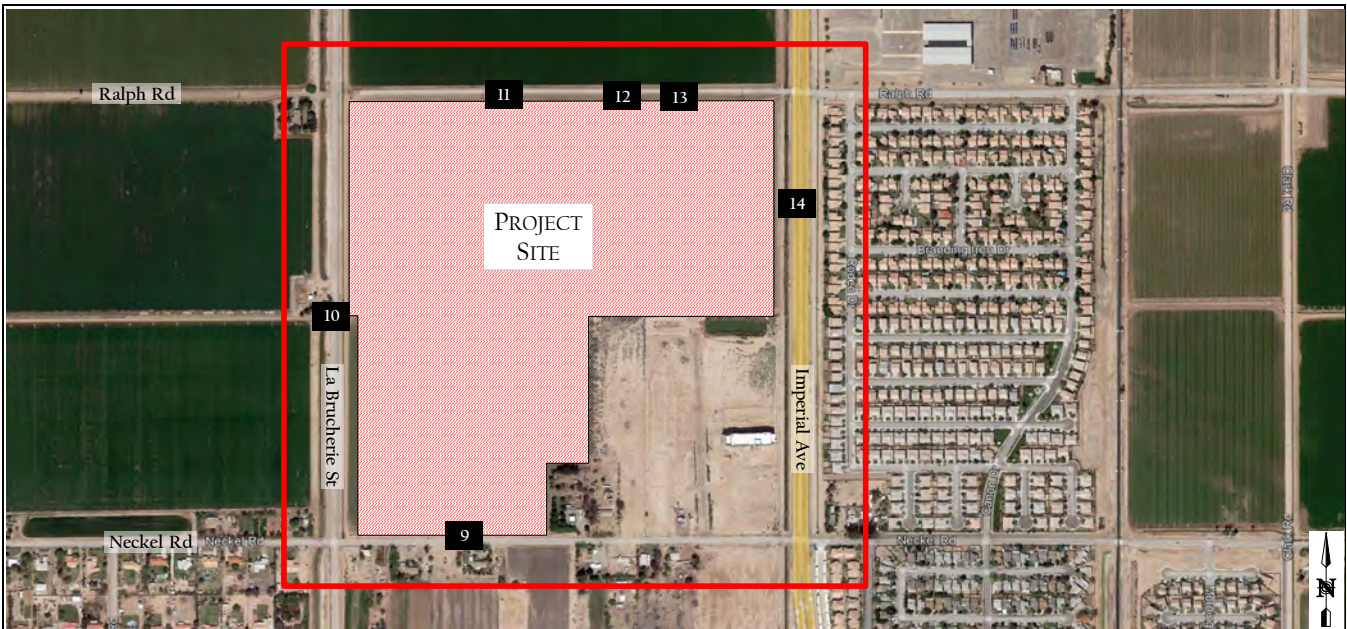

xx / yy - AM / PM Peak-Hour Turning Movement Volumes
 The naming convention for intersections is North / South & East / West

Proj Dwy & Neckel Rd	La Brucherie Rd & Proj Dwy	SFR Proj Dwy & Ralph Rd	MFR Proj Dwy & Ralph Rd
Does not exist	Does not exist	Does not exist	Does not exist
Retail Proj Dwy & Ralph Rd	Imperial Ave & Proj Dwy		
Does not exist	Does not exist		



Heritage at Dahlia Ranch
 Opening Year 2028 Baseline Traffic Volumes

Figure 9-2a

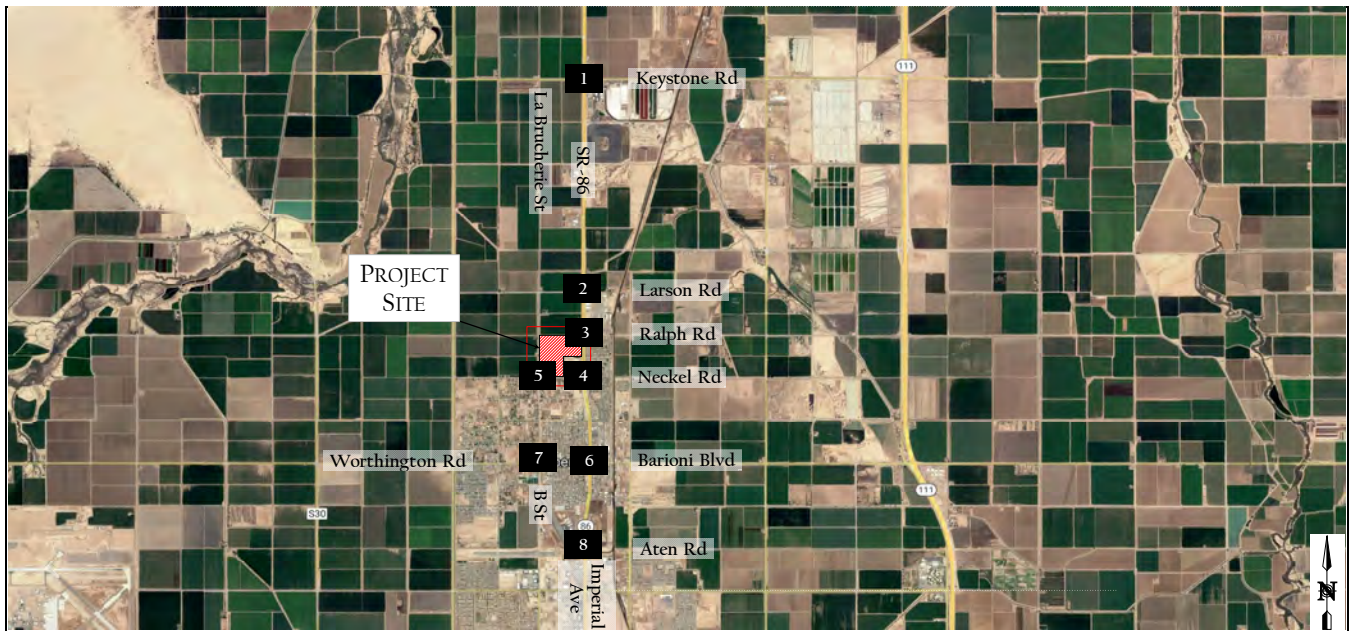

xx / yy - AM / PM Peak-Hour Turning Movement Volumes
 The naming convention for intersections is North / South & East / West

SR-86 & Keystone Rd		SR-86 & Larsen Rd		Imperial Ave & Ralph Rd		Imperial Ave & Neckel Rd	
40 / 36 ↘ ↙ 620 / 734 ↘ ↙ 48 / 56 ↘ ↙ 45 / 40 ↘ ↙ 25 / 29 ↘ ↙ 20 / 35 ↘ ↙	1	8 / 19 ↘ ↙ 625 / 772 ↘ ↙ 1 / 7 ↘ ↙ 6 / 6 ↘ ↙ 2 / 0 ↘ ↙ 1 / 8 ↘ ↙	2	39 / 84 ↘ ↙ 362 / 629 ↘ ↙ 27 / 53 ↘ ↙ 45 / 23 ↘ ↙ 17 / 18 ↘ ↙ 127 / 58 ↘ ↙	3	33 / 30 ↘ ↙ 750 / 723 ↘ ↙ 35 / 83 ↘ ↙ 104 / 86 ↘ ↙ 68 / 21 ↘ ↙ 232 / 141 ↘ ↙	4
35 / 44 ↘ ↙ 35 / 13 ↘ ↙ 12 / 21 ↘ ↙ 20 / 11 ↘ ↙ 601 / 672 ↘ ↙ 53 / 28 ↘ ↙		21 / 7 ↘ ↙ 3 / 4 ↘ ↙ 2 / 0 ↘ ↙ 0 / 1 ↘ ↙ 672 / 713 ↘ ↙ 1 / 8 ↘ ↙		82 / 81 ↘ ↙ 11 / 22 ↘ ↙ 106 / 90 ↘ ↙ 134 / 192 ↘ ↙ 546 / 621 ↘ ↙ 63 / 96 ↘ ↙		36 / 13 ↘ ↙ 46 / 28 ↘ ↙ 143 / 90 ↘ ↙ 54 / 159 ↘ ↙ 610 / 834 ↘ ↙ 96 / 180 ↘ ↙	
La Brucherie Rd & Neckel Rd		Imperial Ave & Barioni Blvd / Worthington Rd		B St / La Brucherie Rd & Worthington Rd		Imperial Ave & Aten Rd	
1 / 8 ↘ ↙ 36 / 42 ↘ ↙ 155 / 146 ↘ ↙ 94 / 193 ↘ ↙ 47 / 47 ↘ ↙ 71 / 29 ↘ ↙	5	84 / 82 ↘ ↙ 1022 / 910 ↘ ↙ 84 / 70 ↘ ↙ 111 / 107 ↘ ↙ 141 / 120 ↘ ↙ 58 / 58 ↘ ↙	6	110 / 66 ↘ ↙ 33 / 6 ↘ ↙ 114 / 40 ↘ ↙ 83 / 36 ↘ ↙ 347 / 245 ↘ ↙ 12 / 29 ↘ ↙	7	468 / 280 ↘ ↙ 959 / 755 ↘ ↙ 194 / 161 ↘ ↙ 179 / 183 ↘ ↙ 321 / 309 ↘ ↙ 140 / 191 ↘ ↙	8
4 / 2 ↘ ↙ 44 / 41 ↘ ↙ 24 / 9 ↘ ↙ 8 / 6 ↘ ↙ 33 / 50 ↘ ↙ 48 / 19 ↘ ↙		83 / 78 ↘ ↙ 145 / 79 ↘ ↙ 227 / 112 ↘ ↙ 99 / 120 ↘ ↙ 670 / 1114 ↘ ↙ 54 / 15 ↘ ↙		93 / 80 ↘ ↙ 426 / 227 ↘ ↙ 128 / 35 ↘ ↙ 0 / 1 ↘ ↙ 1 / 0 ↘ ↙		236 / 281 ↘ ↙ 362 / 295 ↘ ↙ 67 / 73 ↘ ↙ 65 / 84 ↘ ↙ 475 / 982 ↘ ↙ 72 / 160 ↘ ↙	

	Heritage at Dahlia Ranch Opening Year 2028 Plus Phases 1 to 4 Project Traffic Volumes	Figure 9-3
--	---	------------

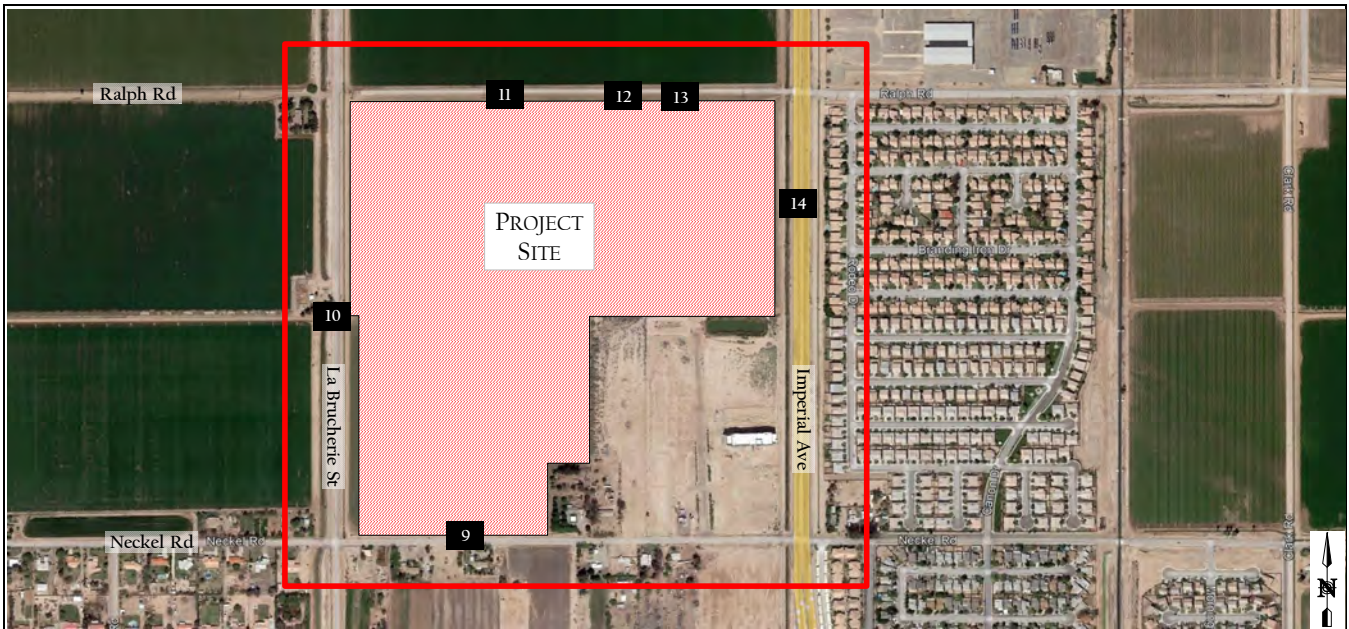

xx / yy - AM / PM Peak-Hour Turning Movement Volumes
 The naming convention for intersections is North / South & East / West

Proj Dwy & Neckel Rd	La Brucherie Rd & Proj Dwy	SFR Proj Dwy & Ralph Rd	MFR Proj Dwy & Ralph Rd
Retail Proj Dwy & Ralph Rd	Imperial Ave & Proj Dwy		



Heritage at Dahlia Ranch
 Opening Year 2028 Plus Phases 1 to 4 Project Traffic Volumes

Figure 9-3a

Table 9-1
Opening Year 2028 Peak Hour Intersection LOS Summary

#	Intersection	Traffic Control	Peak Hour	Opening Year 2028		Opening Year 2028 w/Phases 1 to 4 Proj		Δ in Delay	Improvement?
				Delay ¹	LOS ²	Delay ¹	LOS ²		
1	SR-86 & Keystone Rd	Signal	AM	9.4	A	9.4	A	0.0	No
			PM	9.4	A	9.5	A	0.1	No
2	SR-86 & Larson Rd	TWSC	AM	16.3	C	17.6	C	1.3	No
			PM	19.1	C	21.6	C	2.5	No
3	Imperial Ave & Ralph Rd	Signal	AM	40.3	E	19.6	B	-20.7	No
			PM	34.0	D	24.1	C	-9.9	No
4	Imperial Ave & Neckel Rd	Signal	AM	24.9	C	50.1	D	25.2	No
			PM	20.4	C	54.0	D	33.6	No
5	La Brucherie Rd & Neckel Rd	TWSC	AM	10.4	B	20.7	C	10.3	No
			PM	9.8	A	15.5	C	5.7	No
6	Imperial Ave & Worthington Rd/Barioni Blvd	Signal	AM	42.9	D	48.4	D	5.5	No
			PM	28.3	C	33.3	C	5.0	No
7	La Brucherie Rd & Worthington Rd	AWSC	AM	25.7	D	34.2	D	8.5	No
			PM	11.7	B	13.3	B	1.6	No
8	Imperial Ave & Aten Rd	Signal	AM	40.2	D	51.6	D	11.4	No
			PM	31.2	C	52.8	D	21.6	No
9	Proj Dwy & Neckel Rd	OWSC	AM	DNE		10.9	B	10.9	No
			PM	DNE		10.5	B	10.5	No
10	La Brucherie Rd & Proj Dwy	TWSC	AM	DNE		10.4	B	10.4	No
			PM	DNE		12.1	B	12.1	No
11	SFR Proj Dwy & Ralph Rd	OWSC	AM	DNE		8.9	A	8.9	No
			PM	DNE		8.8	A	8.8	No
12	MFR Proj Dwy & Ralph Rd	OWSC	AM	DNE		9.3	A	9.3	No
			PM	DNE		10.7	B	10.7	No
13	Retail Proj Dwy & Ralph Rd	OWSC	AM	DNE		11.2	B	11.2	No
			PM	DNE		11.7	B	11.7	No
14	Imperial Ave & Proj Dwy	OWSC	AM	DNE		12.2	B	12.2	No
			PM	DNE		13.0	B	13.0	No

Notes:

OWSC: One-Way Stopped Control, TWSC: Two-Way Stopped Control, AWSC: All-Way Stopped Control

1. Delays are reported as the average control delay for the entire intersection at signalized intersections and the worst movement at unsignalized intersections.

2. LOS calculations are based on the methodology outlined in the *Highway Capacity Manual 6th Edition (HCM6)* and performed using Synchro II.

As shown in the table, all intersections, including the project driveways, are expected to operate at LOS D or better during the weekday peak-hours with the addition of the Project traffic. As a result, no additional intersection improvements are required and/or recommended.

9.4 Roadway Segment Analysis

Table 9-2 displays the LOS analysis for the study area roadway segments under the Opening Year 2028 with and without the Phase 4 Project traffic.

Table 9-2
Opening Year 2028 Roadway LOS Summary

Roadway Segment	Opening Year 2028			Opening Year 2028 w/Phases 1 to 4 Proj			Δ in V/C	Improvement?
	ADT	v/c Ratio	LOS	ADT	v/c Ratio	LOS		
SR-86								
North of Keystone Rd	17,233	0.47	B	19,338	0.52	B	0.057	No
Keystone Rd to Larsen Rd	16,491	0.45	B	18,596	0.50	B	0.057	No
Larsen Rd to Ralph Rd	15,881	0.43	B	17,986	0.49	B	0.057	No
Imperial Ave								
Ralph Rd to Neckel Rd	17,206	0.47	B	22,392	0.61	B	0.140	No
Neckel Rd to Worthington Rd	22,607	0.61	B	28,334	0.77	C	0.155	No
Worthington Rd to Aten Rd	24,181	0.65	B	29,295	0.79	C	0.138	No
South of Aten Rd	25,224	0.68	C	28,231	0.76	C	0.081	No

As shown in the table, all roadway segments would continue to function at LOS C or better with the addition of the project traffic. As a result, no additional improvements are required and/or recommended.

10 SUMMARY OF FINDINGS AND RECOMMENDATIONS

The following list summarizes the key findings for the Project:

- The Project consists of constructing 266 single family residential detached housing, 200 apartment units, and 92,120 sf of various commercial/retail uses on the vacant site generally bounded by Neckel Road to the north, Ralph Road to the south, Imperial Avenue to the east, and La Brucherie Road to the west.
- The project would be constructed over four phases.
 - Phase 1: 133 single family residential units (Year 2023)
 - Phase 2: 133 single family residential units (Year 2024)
 - Phase 3: 200 apartment units and 92,120 square feet (sf) of various commercial/retail (Year 2026)
 - Phase 4: 202 single family residential units (Year 2028)
- In Phase 1, the Project will construct an eastbound left-turn lane at the Project driveway off Neckel Road.
- In Phase 2, the Project will construct a southbound left-turn lane at the Project driveway off La Brucherie Road.
- In Phase 3, the Project will construct and extend Ralph Road west from Imperial Avenue until La Brucherie Road. The Imperial Avenue & Ralph Road intersection will be upgraded to include a traffic signal. The Project will construct a westbound left-turn lane along Ralph Road for entering traffic to access the multi-family and commercial/retail uses. Additionally, a southbound right-turn deceleration lane will be constructed at the new driveway along Imperial Highway.
- In Phase 4, the Project will construct the west leg of the La Brucherie Road & Project Driveway intersection. The Project will also construct a northbound left-turn lane along La Brucherie Road for entering traffic.
- The Project is forecasted to generate 11,785 daily trips with 691 AM peak-hour trips and 916 PM peak-hour trips at the project driveways.
- The Clark 54 cumulative project was added to the baseline traffic volumes and included in the analyses.
- All intersections, roadway segments, and the project driveways in the study area are expected to operate at an acceptable LOS D or better under all scenarios.

This traffic study has been prepared in accordance with the *County of Imperial Department of Public Works Traffic Study and Report Policy, June 29, 2007*. The proposed Project will not result in any deficient facilities in the study area and no improvements other than the ones listed above are required or recommended of the proposed Project.

Appendix A

SR-86 Relinquishment Map

STATE OF CALIFORNIA
DEPARTMENT OF TRANSPORTATION

RELINQUISHMENT OF
STATE HIGHWAY 86

IN IMPERIAL COUNTY, CITY OF IMPERIAL
FROM TRESHILL ROAD TO RALPH ROAD

James W. Lindsey
DISTRICT 11 RIGHT OF WAY ENGINEER
DATE: Oct. 24 2016
PROFESSIONAL LAND SURVEYOR
L.S. 8355
Exp. 12/31/2017
STATE OF CALIFORNIA



NOTE:
STATE'S RIGHTS ARE NOT EXTINGUISHED UNTIL
RECORDATION OF RELATED CTC RESOLUTION.

CALIFORNIA TRANSPORTATION COMMISSION
RESOLUTION DATE: 12-07-2016
CTC NO.: R-3974

CTC RESOLUTION RECORDING DATA
REC. DATE: 01-10-2017
FILE NO.: 2017000522

STATE HIGHWAY MAP RECORDING DATA
BOOK 5 PAGES 54
FILE NO: 2016 022 081
FILE AT THE REQUEST OF THE CALIFORNIA STATE
TRANSPORTATION AGENCY, DEPARTMENT OF
TRANSPORTATION, DISTRICT 11.

THIS 26TH DAY OF OCTOBER 20 16, AT 10:31 AM

COUNTY RECORDER FEE: 0
CHUCK STOREY, COUNTY RECORDER

BY: *Chuck Storey*
DEPUTY COUNTY RECORDER

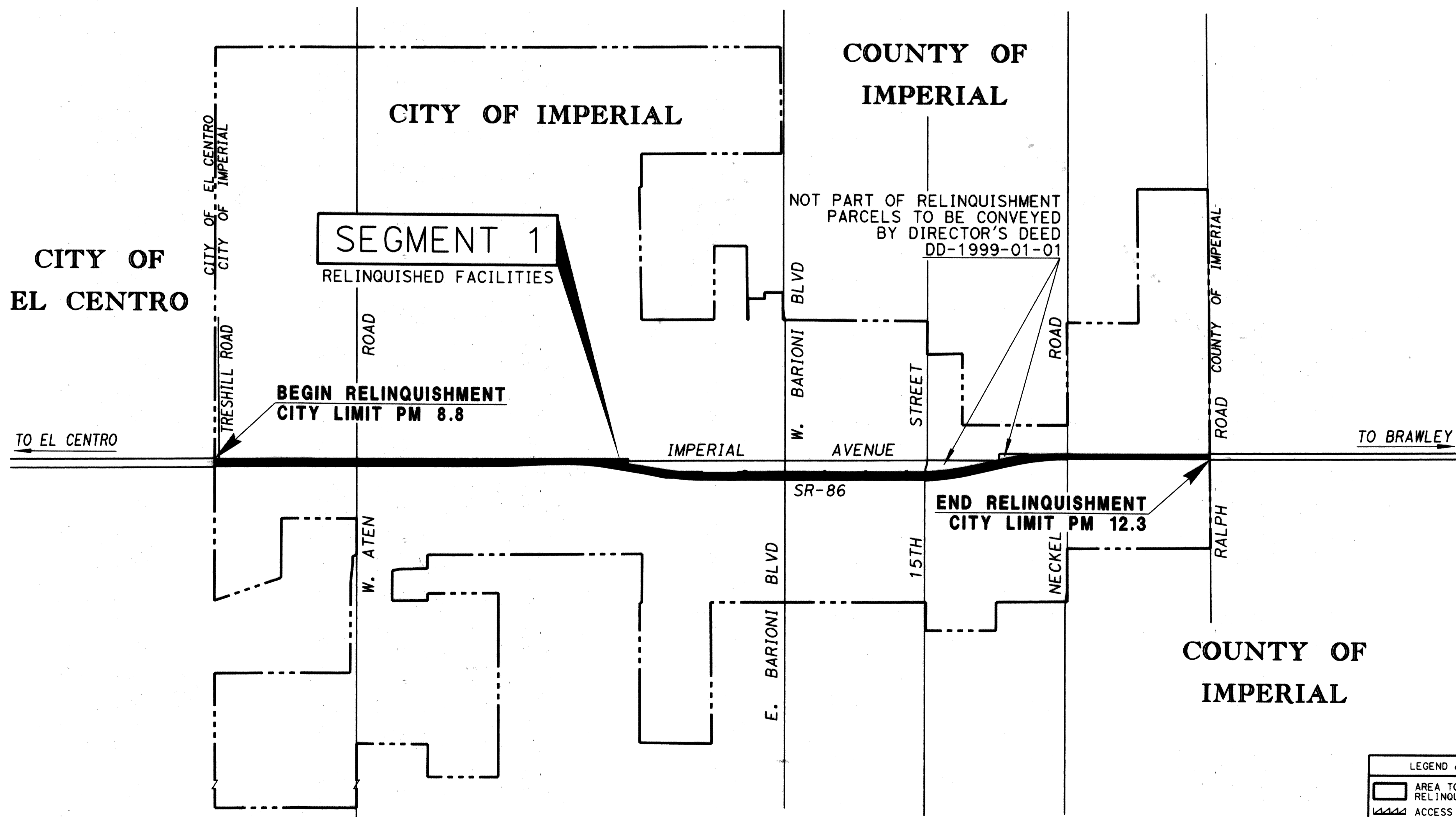

LEGEND & NOTES

- AREA TO BE RELINQUISHED
- ACCESS RELINQUISHED
- ACCESS DENIED
- ACCESS OPENING

P.N.: 1114000050
E.A.:

STATE OF CALIFORNIA DEPARTMENT OF TRANSPORTATION DISTRICT 11			
RELINQUISHMENT MAP			
Relinquishment No. R31136			
RIGHT OF WAY MAP NO.			
COUNTY ROUTE	POST MILE	SCALE	
111	86	8.8 - 12.3	1" = 1000'
			SHEET 1 OF 2

STATE OF CALIFORNIA
DEPARTMENT OF TRANSPORTATION

RELINQUISHMENT OF
STATE HIGHWAY 86

IN IMPERIAL COUNTY, CITY OF IMPERIAL
FROM TRESHILL ROAD TO RALPH ROAD

James W. Lindsey
Oct 24, 2016
DATE

PROFESSIONAL LAND SURVEYOR
JAMES W. LINDSEY
L.S. 8355
Exp. 12/31/2017
STATE OF CALIFORNIA

PARCEL MAP
NO. M-1955

TRACT 56
(W. 80 AC.)

CITY OF
IMPERIAL
T. 15 S. R. 14 E. S.B.M.



COUNTY OF
IMPERIAL

T. 15 S. R. 14 E. S.B.M.

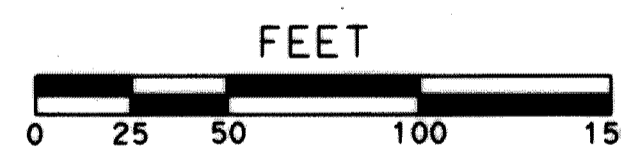
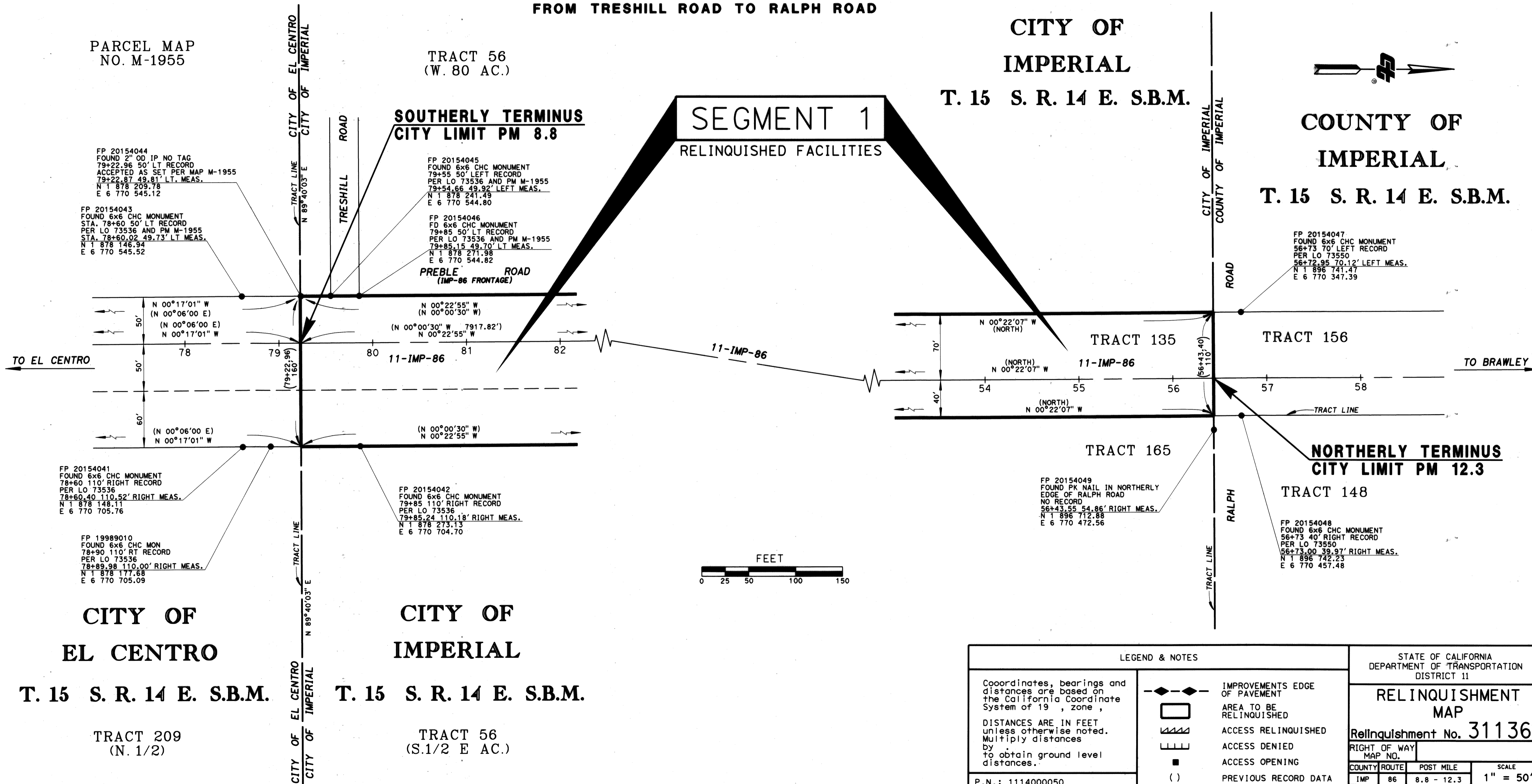

CITY OF
EL CENTRO
T. 15 S. R. 14 E. S.B.M.

CITY OF
IMPERIAL
T. 15 S. R. 14 E. S.B.M.

TRACT 209
(N. 1/2)

TRACT 56
(S.1/2 E AC.)

LEGEND & NOTES		STATE OF CALIFORNIA DEPARTMENT OF TRANSPORTATION DISTRICT 11	
Coordinates, bearings and distances are based on the California Coordinate System of 1983, zone 10N.	IMPROVEMENTS EDGE OF PAVEMENT	RELINQUISHMENT MAP Relinquishment No. 31136	
DISTANCES ARE IN FEET unless otherwise noted. Multiply distances by 1.000 to obtain ground level distances.	AREA TO BE RELINQUISHED		
P.N.: 1114000050 E.A.	ACCESS RELINQUISHED	RIGHT OF WAY MAP NO.	
	ACCESS DENIED	COUNTY ROUTE	POST MILE
	ACCESS OPENING	IMP	86
	PREVIOUS RECORD DATA	SCALE 1" = 50'	
		SHEET 2 OF 2	

Appendix B

Existing Traffic Volume Data

County of Imperial
 N/S: SR-86
 E/W: Keystone Road
 Weather: Clear

File Name : 01_CIM_SR-86_Keystone AM
 Site Code : 99921570
 Start Date : 10/13/2021
 Page No : 1

Groups Printed- Total Volume

Start Time	SR-86 Southbound				Keystone Road Westbound				SR-86 Northbound				Keystone Road Eastbound				Int. Total
	Left	Thru	Right	App. Total	Left	Thru	Right	App. Total	Left	Thru	Right	App. Total	Left	Thru	Right	App. Total	
07:00 AM	6	84	5	95	6	2	5	13	2	93	8	103	8	10	0	18	229
07:15 AM	10	124	10	144	0	5	3	8	7	115	11	133	8	8	4	20	305
07:30 AM	18	130	10	158	6	6	14	26	4	108	16	128	14	8	1	23	335
07:45 AM	10	125	8	143	7	6	12	25	6	132	15	153	9	11	0	20	341
Total	44	463	33	540	19	19	34	72	19	448	50	517	39	37	5	81	1210
08:00 AM	6	119	8	133	5	6	12	23	1	72	6	79	1	5	6	12	247
08:15 AM	6	88	5	99	7	4	8	19	3	103	6	112	9	2	3	14	244
08:30 AM	8	84	5	97	9	7	12	28	0	82	6	88	6	5	2	13	226
08:45 AM	6	90	7	103	3	0	14	17	1	91	4	96	6	4	1	11	227
Total	26	381	25	432	24	17	46	87	5	348	22	375	22	16	12	50	944
Grand Total	70	844	58	972	43	36	80	159	24	796	72	892	61	53	17	131	2154
Apprch %	7.2	86.8	6		27	22.6	50.3		2.7	89.2	8.1		46.6	40.5	13		
Total %	3.2	39.2	2.7	45.1	2	1.7	3.7	7.4	1.1	37	3.3	41.4	2.8	2.5	0.8	6.1	

Start Time	SR-86 Southbound				Keystone Road Westbound				SR-86 Northbound				Keystone Road Eastbound				Int. Total
	Left	Thru	Right	App. Total	Left	Thru	Right	App. Total	Left	Thru	Right	App. Total	Left	Thru	Right	App. Total	
07:15 AM	10	124	10	144	0	5	3	8	7	115	11	133	8	8	4	20	305
07:30 AM	18	130	10	158	6	6	14	26	4	108	16	128	14	8	1	23	335
07:45 AM	10	125	8	143	7	6	12	25	6	132	15	153	9	11	0	20	341
08:00 AM	6	119	8	133	5	6	12	23	1	72	6	79	1	5	6	12	247
Total Volume	44	498	36	578	18	23	41	82	18	427	48	493	32	32	11	75	1228
% App. Total	7.6	86.2	6.2		22	28	50		3.7	86.6	9.7		42.7	42.7	14.7		
PHF	.611	.958	.900	.915	.643	.958	.732	.788	.643	.809	.750	.806	.571	.727	.458	.815	.900

Peak Hour Analysis From 07:00 AM to 08:45 AM - Peak 1 of 1
 Peak Hour for Entire Intersection Begins at 07:15 AM

County of Imperial
 N/S: SR-86
 E/W: Keystone Road
 Weather: Clear

File Name : 01_CIM_SR-86_Keystone AM
 Site Code : 99921570
 Start Date : 10/13/2021
 Page No : 2

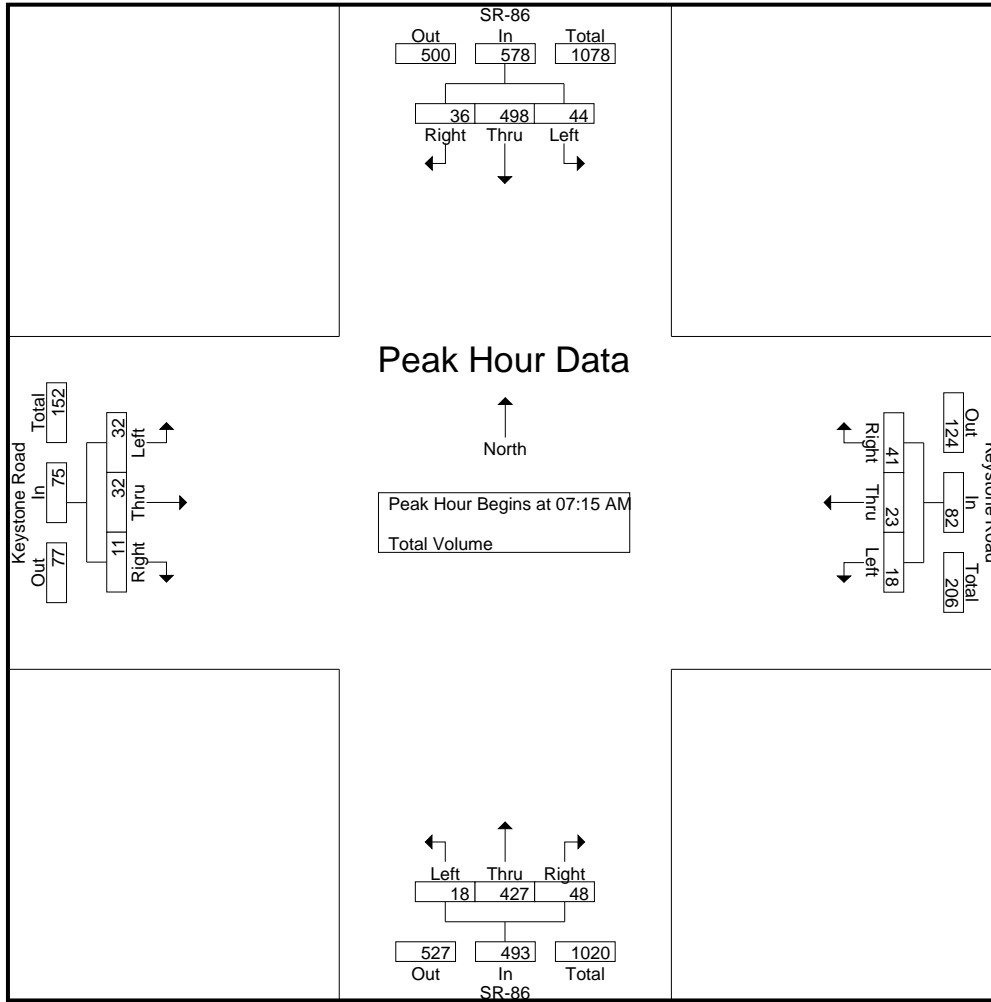

Peak Hour Analysis From 07:00 AM to 08:45 AM - Peak 1 of 1
 Peak Hour for Each Approach Begins at:

	07:15 AM				07:45 AM				07:00 AM				07:00 AM			
+0 mins.	10	124	10	144	7	6	12	25	2	93	8	103	8	10	0	18
+15 mins.	18	130	10	158	5	6	12	23	7	115	11	133	8	8	4	20
+30 mins.	10	125	8	143	7	4	8	19	4	108	16	128	14	8	1	23
+45 mins.	6	119	8	133	9	7	12	28	6	132	15	153	9	11	0	20
Total Volume	44	498	36	578	28	23	44	95	19	448	50	517	39	37	5	81
% App. Total	7.6	86.2	6.2		29.5	24.2	46.3		3.7	86.7	9.7		48.1	45.7	6.2	
PHF	.611	.958	.900	.915	.778	.821	.917	.848	.679	.848	.781	.845	.696	.841	.313	.880

County of Imperial
 N/S: SR-86
 E/W: Keystone Road
 Weather: Clear

File Name : 01_CIM_SR-86_Keystone PM
 Site Code : 99921570
 Start Date : 10/13/2021
 Page No : 1

Groups Printed- Total Volume

Start Time	SR-86 Southbound				Keystone Road Westbound				SR-86 Northbound				Keystone Road Eastbound				Int. Total
	Left	Thru	Right	App. Total	Left	Thru	Right	App. Total	Left	Thru	Right	App. Total	Left	Thru	Right	App. Total	
04:00 PM	7	116	8	131	7	6	7	20	4	108	5	117	9	3	1	13	281
04:15 PM	10	122	8	140	4	8	14	26	5	124	4	133	7	2	8	17	316
04:30 PM	9	108	7	124	7	7	15	29	3	103	6	112	10	2	4	16	281
04:45 PM	16	135	12	163	13	6	7	26	3	138	5	146	13	3	8	24	359
Total	42	481	35	558	31	27	43	101	15	473	20	508	39	10	21	70	1237
05:00 PM	13	126	8	147	6	6	5	17	1	133	7	141	1	2	3	6	311
05:15 PM	13	158	6	177	6	7	9	22	3	135	7	145	16	5	4	25	369
05:30 PM	9	115	5	129	6	2	10	18	2	112	4	118	9	1	0	10	275
05:45 PM	4	71	7	82	6	4	11	21	4	148	5	157	3	1	2	6	266
Total	39	470	26	535	24	19	35	78	10	528	23	561	29	9	9	47	1221
Grand Total	81	951	61	1093	55	46	78	179	25	1001	43	1069	68	19	30	117	2458
Apprch %	7.4	87	5.6		30.7	25.7	43.6		2.3	93.6	4		58.1	16.2	25.6		
Total %	3.3	38.7	2.5	44.5	2.2	1.9	3.2	7.3	1	40.7	1.7	43.5	2.8	0.8	1.2	4.8	

Start Time	SR-86 Southbound				Keystone Road Westbound				SR-86 Northbound				Keystone Road Eastbound				Int. Total
	Left	Thru	Right	App. Total	Left	Thru	Right	App. Total	Left	Thru	Right	App. Total	Left	Thru	Right	App. Total	
04:30 PM	9	108	7	124	7	7	15	29	3	103	6	112	10	2	4	16	281
04:45 PM	16	135	12	163	13	6	7	26	3	138	5	146	13	3	8	24	359
05:00 PM	13	126	8	147	6	6	5	17	1	133	7	141	1	2	3	6	311
05:15 PM	13	158	6	177	6	7	9	22	3	135	7	145	16	5	4	25	369
Total Volume	51	527	33	611	32	26	36	94	10	509	25	544	40	12	19	71	1320
% App. Total	8.3	86.3	5.4		34	27.7	38.3		1.8	93.6	4.6		56.3	16.9	26.8		
PHF	.797	.834	.688	.863	.615	.929	.600	.810	.833	.922	.893	.932	.625	.600	.594	.710	.894

Peak Hour Analysis From 04:00 PM to 05:45 PM - Peak 1 of 1
 Peak Hour for Entire Intersection Begins at 04:30 PM

County of Imperial
 N/S: SR-86
 E/W: Keystone Road
 Weather: Clear

File Name : 01_CIM_SR-86_Keystone PM
 Site Code : 99921570
 Start Date : 10/13/2021
 Page No : 2

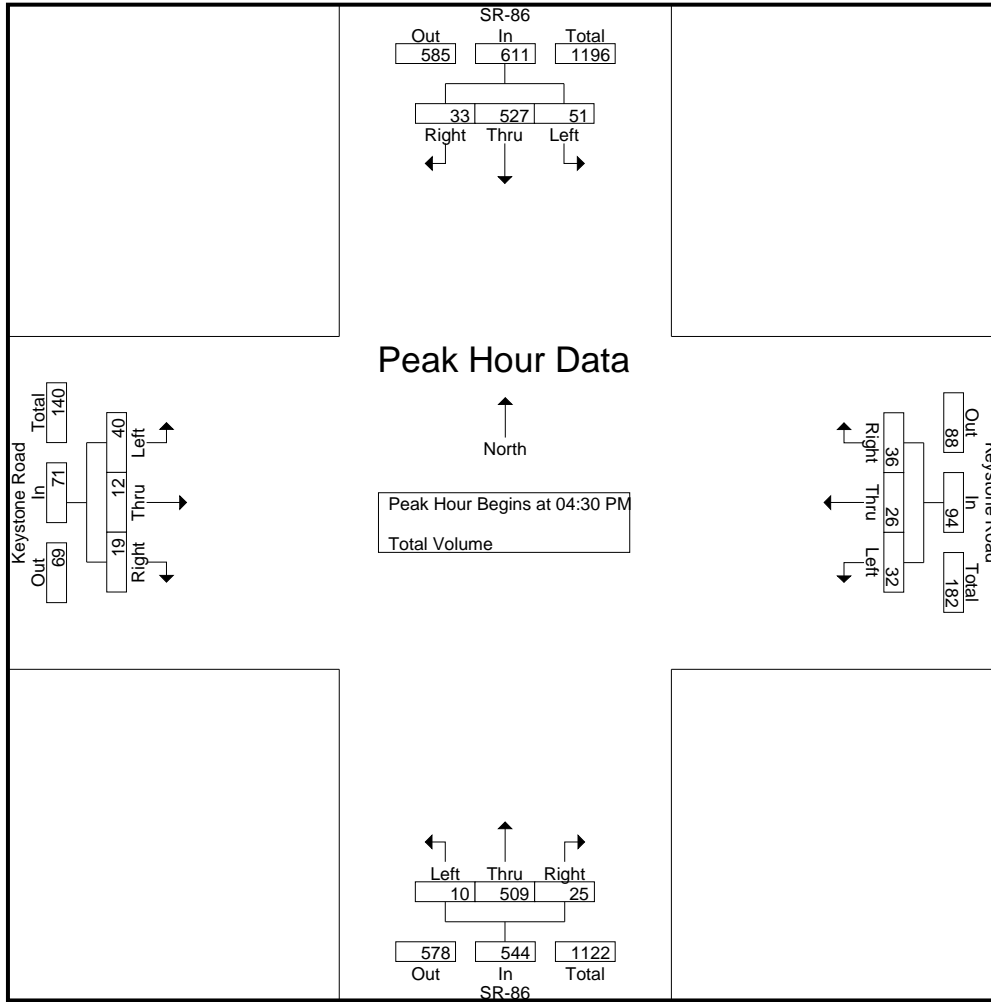

Peak Hour Analysis From 04:00 PM to 05:45 PM - Peak 1 of 1
 Peak Hour for Each Approach Begins at:

	04:45 PM				04:00 PM				05:00 PM				04:30 PM			
+0 mins.	16	135	12	163	7	6	7	20	1	133	7	141	10	2	4	16
+15 mins.	13	126	8	147	4	8	14	26	3	135	7	145	13	3	8	24
+30 mins.	13	158	6	177	7	7	15	29	2	112	4	118	1	2	3	6
+45 mins.	9	115	5	129	13	6	7	26	4	148	5	157	16	5	4	25
Total Volume	51	534	31	616	31	27	43	101	10	528	23	561	40	12	19	71
% App. Total	8.3	86.7	5		30.7	26.7	42.6		1.8	94.1	4.1		56.3	16.9	26.8	
PHF	.797	.845	.646	.870	.596	.844	.717	.871	.625	.892	.821	.893	.625	.600	.594	.710

County of Imperial
 N/S: SR-86
 E/W: Larsen Road
 Weather: Clear

File Name : 02_CIM_SR-86_Larsen AM
 Site Code : 99921570
 Start Date : 10/13/2021
 Page No : 1

Groups Printed- Total Volume

Start Time	SR-86 Southbound				Larsen Road Westbound				SR-86 Northbound				Larsen Road Eastbound				Int. Total
	Left	Thru	Right	App. Total	Left	Thru	Right	App. Total	Left	Thru	Right	App. Total	Left	Thru	Right	App. Total	
07:00 AM	0	67	0	67	0	0	1	1	1	99	1	101	7	2	0	9	178
07:15 AM	0	118	2	120	0	2	2	4	0	129	0	129	7	0	0	7	260
07:30 AM	0	128	1	129	0	0	1	1	0	142	0	142	3	1	0	4	276
07:45 AM	1	131	2	134	0	0	1	1	0	129	0	129	5	2	2	9	273
Total	1	444	5	450	0	2	5	7	1	499	1	501	22	5	2	29	987
08:00 AM	0	126	2	128	1	0	1	2	0	92	1	93	4	0	0	4	227
08:15 AM	0	95	4	99	1	1	1	3	0	98	1	99	2	2	2	6	207
08:30 AM	0	102	1	103	0	1	1	2	0	79	3	82	2	0	0	2	189
08:45 AM	0	94	0	94	0	1	0	1	1	102	1	104	4	0	0	4	203
Total	0	417	7	424	2	3	3	8	1	371	6	378	12	2	2	16	826
Grand Total	1	861	12	874	2	5	8	15	2	870	7	879	34	7	4	45	1813
Apprch %	0.1	98.5	1.4		13.3	33.3	53.3		0.2	99	0.8		75.6	15.6	8.9		
Total %	0.1	47.5	0.7	48.2	0.1	0.3	0.4	0.8	0.1	48	0.4	48.5	1.9	0.4	0.2	2.5	

Start Time	SR-86 Southbound				Larsen Road Westbound				SR-86 Northbound				Larsen Road Eastbound				Int. Total
	Left	Thru	Right	App. Total	Left	Thru	Right	App. Total	Left	Thru	Right	App. Total	Left	Thru	Right	App. Total	
07:15 AM	0	118	2	120	0	2	2	4	0	129	0	129	7	0	0	7	260
07:30 AM	0	128	1	129	0	0	1	1	0	142	0	142	3	1	0	4	276
07:45 AM	1	131	2	134	0	0	1	1	0	129	0	129	5	2	2	9	273
08:00 AM	0	126	2	128	1	0	1	2	0	92	1	93	4	0	0	4	227
Total Volume	1	503	7	511	1	2	5	8	0	492	1	493	19	3	2	24	1036
% App. Total	0.2	98.4	1.4		12.5	25	62.5		0	99.8	0.2		79.2	12.5	8.3		
PHF	.250	.960	.875	.953	.250	.250	.625	.500	.000	.866	.250	.868	.679	.375	.250	.667	.938

Peak Hour Analysis From 07:00 AM to 08:45 AM - Peak 1 of 1
 Peak Hour for Entire Intersection Begins at 07:15 AM

County of Imperial
 N/S: SR-86
 E/W: Larsen Road
 Weather: Clear

File Name : 02_CIM_SR-86_Larsen AM
 Site Code : 99921570
 Start Date : 10/13/2021
 Page No : 2

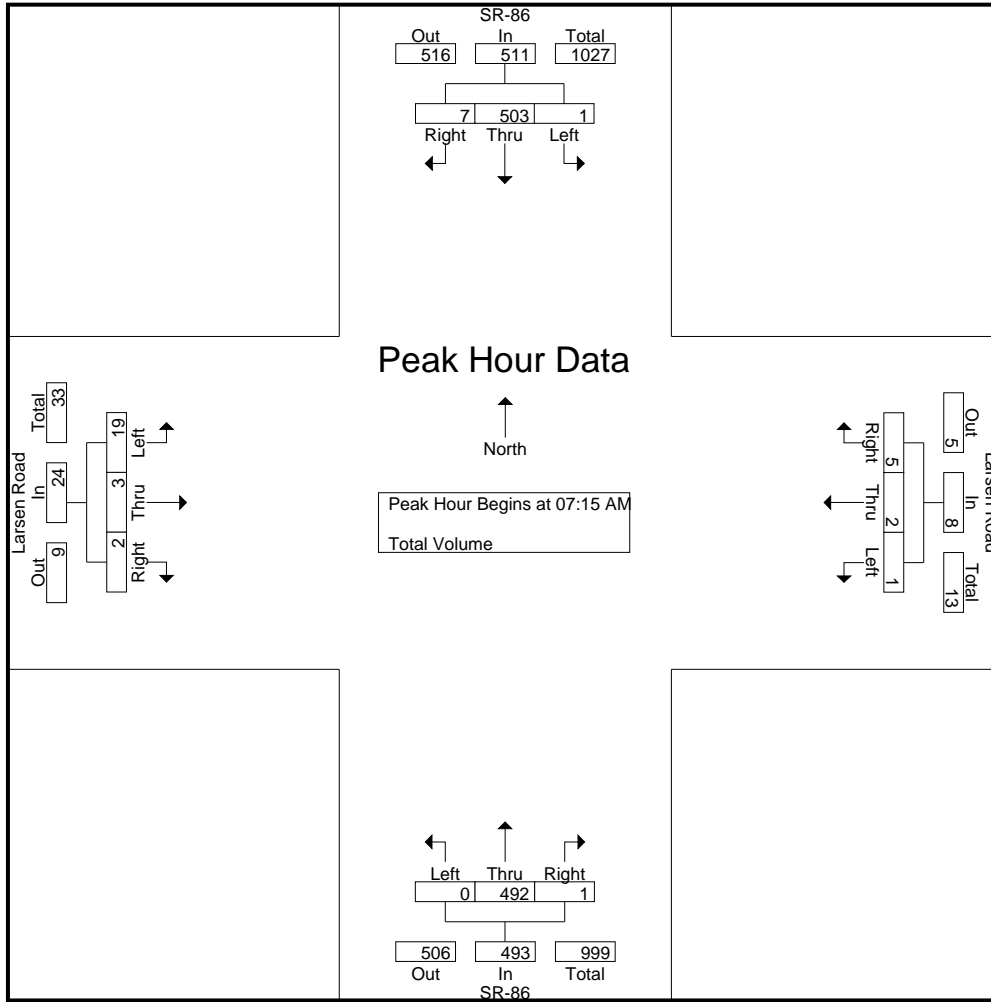

Peak Hour Analysis From 07:00 AM to 08:45 AM - Peak 1 of 1
 Peak Hour for Each Approach Begins at:

	07:15 AM				07:15 AM				07:00 AM				07:00 AM			
+0 mins.	0	118	2	120	0	2	2	4	1	99	1	101	7	2	0	9
+15 mins.	0	128	1	129	0	0	1	1	0	129	0	129	7	0	0	7
+30 mins.	1	131	2	134	0	0	1	1	0	142	0	142	3	1	0	4
+45 mins.	0	126	2	128	1	0	1	2	0	129	0	129	5	2	2	9
Total Volume	1	503	7	511	1	2	5	8	1	499	1	501	22	5	2	29
% App. Total	0.2	98.4	1.4		12.5	25	62.5		0.2	99.6	0.2		75.9	17.2	6.9	
PHF	.250	.960	.875	.953	.250	.250	.625	.500	.250	.879	.250	.882	.786	.625	.250	.806

County of Imperial
 N/S: SR-86
 E/W: Larsen Road
 Weather: Clear

File Name : 02_CIM_SR-86_Larsen PM
 Site Code : 99921570
 Start Date : 10/13/2021
 Page No : 1

Groups Printed- Total Volume

Start Time	SR-86 Southbound				Larsen Road Westbound				SR-86 Northbound				Larsen Road Eastbound				Int. Total
	Left	Thru	Right	App. Total	Left	Thru	Right	App. Total	Left	Thru	Right	App. Total	Left	Thru	Right	App. Total	
04:00 PM	1	136	6	143	1	0	1	2	1	116	1	118	1	0	0	1	264
04:15 PM	3	134	1	138	1	2	0	3	1	133	3	137	0	0	0	0	278
04:30 PM	1	127	3	131	2	1	1	4	2	113	3	118	0	2	2	4	257
04:45 PM	1	134	8	143	2	0	1	3	0	121	0	121	2	1	0	3	270
Total	6	531	18	555	6	3	3	12	4	483	7	494	3	3	2	8	1069
05:00 PM	2	154	4	160	0	0	0	0	0	154	1	155	1	1	0	2	317
05:15 PM	3	160	3	166	4	0	3	7	0	137	2	139	1	1	0	2	314
05:30 PM	0	114	2	116	1	0	1	2	1	134	4	139	2	1	0	3	260
05:45 PM	6	96	0	102	1	2	0	3	1	147	4	152	0	3	2	5	262
Total	11	524	9	544	6	2	4	12	2	572	11	585	4	6	2	12	1153
Grand Total	17	1055	27	1099	12	5	7	24	6	1055	18	1079	7	9	4	20	2222
Apprch %	1.5	96	2.5		50	20.8	29.2		0.6	97.8	1.7		35	45	20		
Total %	0.8	47.5	1.2	49.5	0.5	0.2	0.3	1.1	0.3	47.5	0.8	48.6	0.3	0.4	0.2	0.9	

Start Time	SR-86 Southbound				Larsen Road Westbound				SR-86 Northbound				Larsen Road Eastbound				Int. Total
	Left	Thru	Right	App. Total	Left	Thru	Right	App. Total	Left	Thru	Right	App. Total	Left	Thru	Right	App. Total	
04:45 PM	1	134	8	143	2	0	1	3	0	121	0	121	2	1	0	3	270
05:00 PM	2	154	4	160	0	0	0	0	0	154	1	155	1	1	0	2	317
05:15 PM	3	160	3	166	4	0	3	7	0	137	2	139	1	1	0	2	314
05:30 PM	0	114	2	116	1	0	1	2	1	134	4	139	2	1	0	3	260
Total Volume	6	562	17	585	7	0	5	12	1	546	7	554	6	4	0	10	1161
% App. Total	1	96.1	2.9		58.3	0	41.7		0.2	98.6	1.3		60	40	0		
PHF	.500	.878	.531	.881	.438	.000	.417	.429	.250	.886	.438	.894	.750	1.00	.000	.833	.916

Peak Hour Analysis From 04:00 PM to 05:45 PM - Peak 1 of 1
 Peak Hour for Entire Intersection Begins at 04:45 PM

County of Imperial
 N/S: SR-86
 E/W: Larsen Road
 Weather: Clear

File Name : 02_CIM_SR-86_Larsen PM
 Site Code : 99921570
 Start Date : 10/13/2021
 Page No : 2

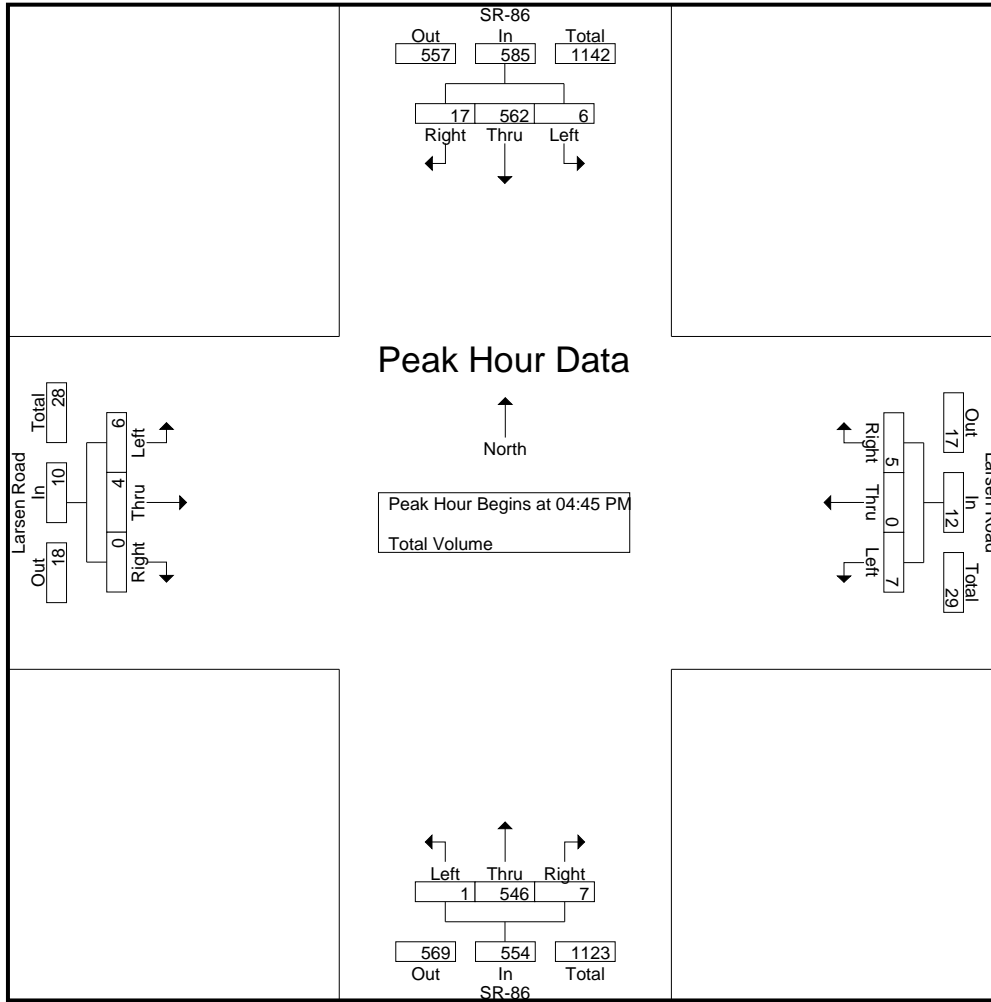

Peak Hour Analysis From 04:00 PM to 05:45 PM - Peak 1 of 1
 Peak Hour for Each Approach Begins at:

	04:30 PM				04:30 PM				05:00 PM				05:00 PM			
+0 mins.	1	127	3	131	2	1	1	4	0	154	1	155	1	1	0	2
+15 mins.	1	134	8	143	2	0	1	3	0	137	2	139	1	1	0	2
+30 mins.	2	154	4	160	0	0	0	0	1	134	4	139	2	1	0	3
+45 mins.	3	160	3	166	4	0	3	7	1	147	4	152	0	3	2	5
Total Volume	7	575	18	600	8	1	5	14	2	572	11	585	4	6	2	12
% App. Total	1.2	95.8	3		57.1	7.1	35.7		0.3	97.8	1.9		33.3	50	16.7	
PHF	.583	.898	.563	.904	.500	.250	.417	.500	.500	.929	.688	.944	.500	.500	.250	.600

City of Imperial
 N/S: SR-86
 E/W: Ralph Road
 Weather: Clear

File Name : 03_IPL_SR-86_Ralph AM
 Site Code : 99921570
 Start Date : 10/13/2021
 Page No : 1

Groups Printed- Total Volume

Start Time	SR-86 Southbound				Ralph Road Westbound				SR-86 Northbound				Ralph Road Eastbound				Int. Total
	Left	Thru	Right	App. Total	Left	Thru	Right	App. Total	Left	Thru	Right	App. Total	Left	Thru	Right	App. Total	
07:00 AM	2	65	0	67	5	0	10	15	0	86	5	91	0	0	0	0	173
07:15 AM	4	115	0	119	7	0	8	15	0	116	9	125	0	0	0	0	259
07:30 AM	7	130	0	137	16	0	4	20	0	138	6	144	0	0	0	0	301
07:45 AM	4	122	0	126	20	0	6	26	0	126	7	133	0	0	0	0	285
Total	17	432	0	449	48	0	28	76	0	466	27	493	0	0	0	0	1018
08:00 AM	4	119	0	123	14	0	4	18	0	91	18	109	0	0	0	0	250
08:15 AM	3	89	0	92	12	0	2	14	0	92	8	100	0	0	0	0	206
08:30 AM	4	101	0	105	5	0	3	8	0	79	3	82	0	0	0	0	195
08:45 AM	0	87	0	87	4	0	6	10	0	95	5	100	0	0	0	0	197
Total	11	396	0	407	35	0	15	50	0	357	34	391	0	0	0	0	848
Grand Total	28	828	0	856	83	0	43	126	0	823	61	884	0	0	0	0	1866
Apprch %	3.3	96.7	0		65.9	0	34.1		0	93.1	6.9		0	0	0		
Total %	1.5	44.4	0	45.9	4.4	0	2.3	6.8	0	44.1	3.3	47.4	0	0	0	0	

Start Time	SR-86 Southbound				Ralph Road Westbound				SR-86 Northbound				Ralph Road Eastbound				Int. Total
	Left	Thru	Right	App. Total	Left	Thru	Right	App. Total	Left	Thru	Right	App. Total	Left	Thru	Right	App. Total	
07:15 AM	4	115	0	119	7	0	8	15	0	116	9	125	0	0	0	0	259
07:30 AM	7	130	0	137	16	0	4	20	0	138	6	144	0	0	0	0	301
07:45 AM	4	122	0	126	20	0	6	26	0	126	7	133	0	0	0	0	285
08:00 AM	4	119	0	123	14	0	4	18	0	91	18	109	0	0	0	0	250
Total Volume	19	486	0	505	57	0	22	79	0	471	40	511	0	0	0	0	1095
% App. Total	3.8	96.2	0		72.2	0	27.8		0	92.2	7.8		0	0	0		
PHF	.679	.935	.000	.922	.713	.000	.688	.760	.000	.853	.556	.887	.000	.000	.000	.000	.909

Peak Hour Analysis From 07:00 AM to 08:45 AM - Peak 1 of 1
 Peak Hour for Entire Intersection Begins at 07:15 AM

City of Imperial
 N/S: SR-86
 E/W: Ralph Road
 Weather: Clear

File Name : 03_IPL_SR-86_Ralph AM
 Site Code : 99921570
 Start Date : 10/13/2021
 Page No : 2

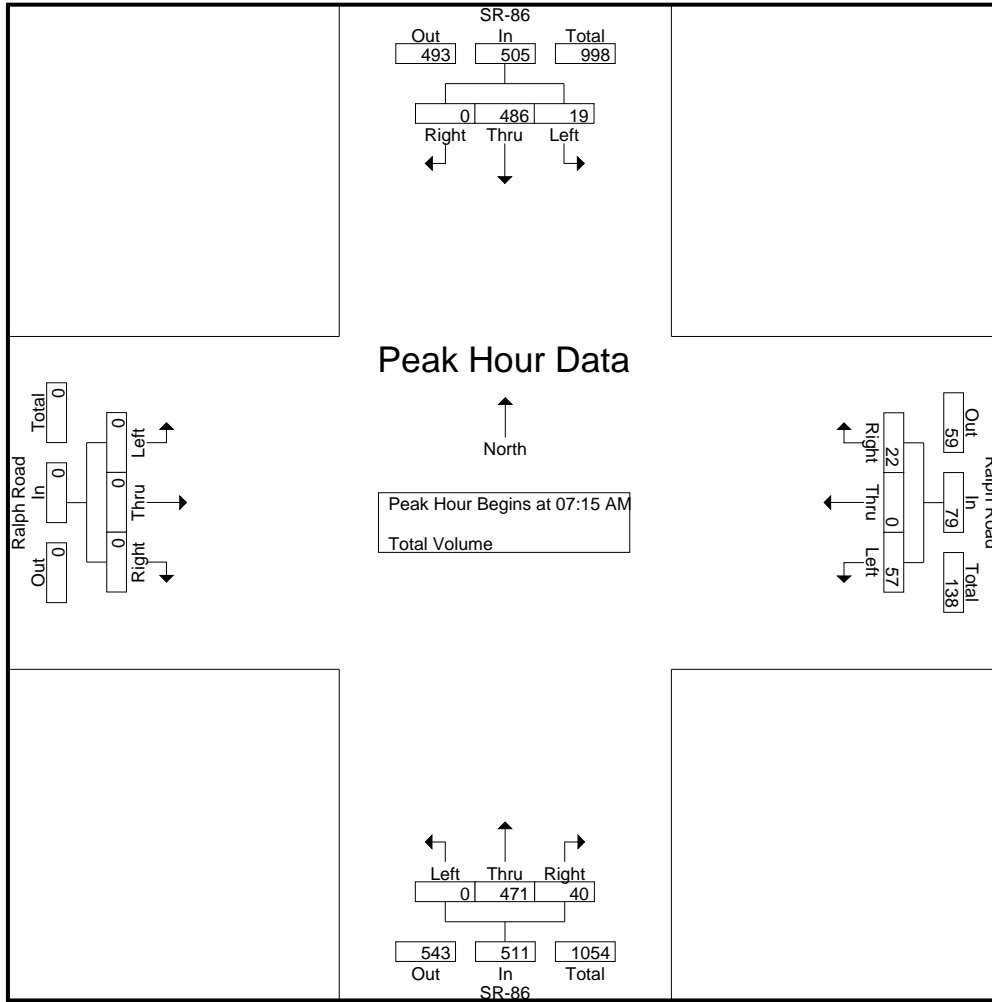

Peak Hour Analysis From 07:00 AM to 08:45 AM - Peak 1 of 1
 Peak Hour for Each Approach Begins at:

	07:15 AM				07:15 AM				07:15 AM				07:00 AM			
+0 mins.	4	115	0	119	7	0	8	15	0	116	9	125	0	0	0	0
+15 mins.	7	130	0	137	16	0	4	20	0	138	6	144	0	0	0	0
+30 mins.	4	122	0	126	20	0	6	26	0	126	7	133	0	0	0	0
+45 mins.	4	119	0	123	14	0	4	18	0	91	18	109	0	0	0	0
Total Volume	19	486	0	505	57	0	22	79	0	471	40	511	0	0	0	0
% App. Total	3.8	96.2	0		72.2	0	27.8		0	92.2	7.8		0	0	0	
PHF	.679	.935	.000	.922	.713	.000	.688	.760	.000	.853	.556	.887	.000	.000	.000	.000

City of Imperial
 N/S: SR-86
 E/W: Ralph Road
 Weather: Clear

File Name : 03_IPL_SR-86_Ralph PM
 Site Code : 99921570
 Start Date : 10/13/2021
 Page No : 1

Groups Printed- Total Volume

Start Time	SR-86 Southbound				Ralph Road Westbound				SR-86 Northbound				Ralph Road Eastbound				Int. Total
	Left	Thru	Right	App. Total	Left	Thru	Right	App. Total	Left	Thru	Right	App. Total	Left	Thru	Right	App. Total	
04:00 PM	5	132	0	137	10	0	2	12	0	106	8	114	0	0	0	0	263
04:15 PM	6	125	0	131	5	0	3	8	1	130	3	134	0	0	0	0	273
04:30 PM	8	116	0	124	10	0	6	16	0	114	8	122	0	0	0	0	262
04:45 PM	9	122	0	131	3	0	2	5	0	117	3	120	0	0	0	0	256
Total	28	495	0	523	28	0	13	41	1	467	22	490	0	0	0	0	1054
05:00 PM	9	137	0	146	3	0	3	6	0	144	7	151	0	0	0	0	303
05:15 PM	6	153	0	159	9	0	0	9	0	138	12	150	0	0	0	0	318
05:30 PM	5	115	0	120	4	0	5	9	0	148	7	155	0	0	0	0	284
05:45 PM	3	92	0	95	6	0	4	10	0	139	5	144	0	0	0	0	249
Total	23	497	0	520	22	0	12	34	0	569	31	600	0	0	0	0	1154
Grand Total	51	992	0	1043	50	0	25	75	1	1036	53	1090	0	0	0	0	2208
Apprch %	4.9	95.1	0		66.7	0	33.3		0.1	95	4.9		0	0	0		
Total %	2.3	44.9	0	47.2	2.3	0	1.1	3.4	0	46.9	2.4	49.4	0	0	0	0	

Start Time	SR-86 Southbound				Ralph Road Westbound				SR-86 Northbound				Ralph Road Eastbound				Int. Total
	Left	Thru	Right	App. Total	Left	Thru	Right	App. Total	Left	Thru	Right	App. Total	Left	Thru	Right	App. Total	
04:45 PM	9	122	0	131	3	0	2	5	0	117	3	120	0	0	0	0	256
05:00 PM	9	137	0	146	3	0	3	6	0	144	7	151	0	0	0	0	303
05:15 PM	6	153	0	159	9	0	0	9	0	138	12	150	0	0	0	0	318
05:30 PM	5	115	0	120	4	0	5	9	0	148	7	155	0	0	0	0	284
Total Volume	29	527	0	556	19	0	10	29	0	547	29	576	0	0	0	0	1161
% App. Total	5.2	94.8	0		65.5	0	34.5		0	95	5		0	0	0		
PHF	.806	.861	.000	.874	.528	.000	.500	.806	.000	.924	.604	.929	.000	.000	.000	.000	.913

Peak Hour Analysis From 04:00 PM to 05:45 PM - Peak 1 of 1
 Peak Hour for Entire Intersection Begins at 04:45 PM

City of Imperial
 N/S: SR-86
 E/W: Ralph Road
 Weather: Clear

File Name : 03_IPL_SR-86_Ralph PM
 Site Code : 99921570
 Start Date : 10/13/2021
 Page No : 2

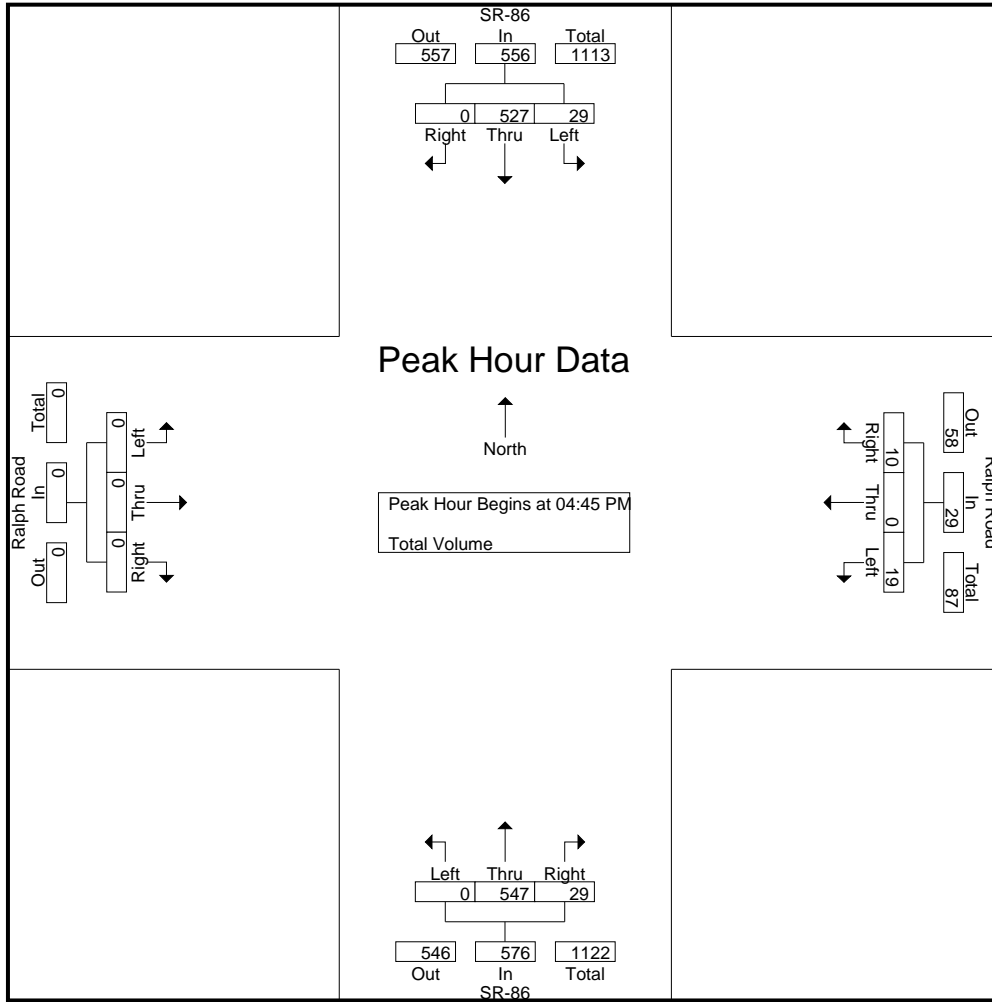

Peak Hour Analysis From 04:00 PM to 05:45 PM - Peak 1 of 1
 Peak Hour for Each Approach Begins at:

	04:30 PM				04:00 PM				05:00 PM				04:00 PM			
+0 mins.	8	116	0	124	10	0	2	12	0	144	7	151	0	0	0	0
+15 mins.	9	122	0	131	5	0	3	8	0	138	12	150	0	0	0	0
+30 mins.	9	137	0	146	10	0	6	16	0	148	7	155	0	0	0	0
+45 mins.	6	153	0	159	3	0	2	5	0	139	5	144	0	0	0	0
Total Volume	32	528	0	560	28	0	13	41	0	569	31	600	0	0	0	0
% App. Total	5.7	94.3	0		68.3	0	31.7		0	94.8	5.2		0	0	0	
PHF	.889	.863	.000	.881	.700	.000	.542	.641	.000	.961	.646	.968	.000	.000	.000	.000

City of Imperial
 N/S: SR-86
 E/W: Neckel Road
 Weather: Clear

File Name : 04_IPL_SR-86_Neckel AM
 Site Code : 99921570
 Start Date : 10/13/2021
 Page No : 1

Groups Printed- Total Volume

Start Time	SR-86 Southbound				Neckel Road Westbound				SR-86 Northbound				Neckel Road Eastbound				Int. Total
	Left	Thru	Right	App. Total	Left	Thru	Right	App. Total	Left	Thru	Right	App. Total	Left	Thru	Right	App. Total	
07:00 AM	2	62	3	67	12	15	17	44	3	80	4	87	9	7	2	18	216
07:15 AM	5	115	5	125	32	14	17	63	3	103	4	110	7	10	2	19	317
07:30 AM	4	123	6	133	43	19	16	78	1	132	8	141	14	9	2	25	377
07:45 AM	4	143	9	156	45	11	8	64	2	106	27	135	8	11	6	25	380
Total	15	443	23	481	132	59	58	249	9	421	43	473	38	37	12	87	1290
08:00 AM	1	116	10	127	18	18	13	49	2	89	24	115	4	12	2	18	309
08:15 AM	3	108	5	116	17	13	12	42	2	81	13	96	5	7	1	13	267
08:30 AM	5	95	2	102	13	6	11	30	1	74	15	90	5	5	3	13	235
08:45 AM	4	101	0	105	9	4	6	19	2	90	4	96	1	1	1	3	223
Total	13	420	17	450	57	41	42	140	7	334	56	397	15	25	7	47	1034
Grand Total	28	863	40	931	189	100	100	389	16	755	99	870	53	62	19	134	2324
Apprch %	3	92.7	4.3		48.6	25.7	25.7		1.8	86.8	11.4		39.6	46.3	14.2		
Total %	1.2	37.1	1.7	40.1	8.1	4.3	4.3	16.7	0.7	32.5	4.3	37.4	2.3	2.7	0.8	5.8	

Start Time	SR-86 Southbound				Neckel Road Westbound				SR-86 Northbound				Neckel Road Eastbound				Int. Total
	Left	Thru	Right	App. Total	Left	Thru	Right	App. Total	Left	Thru	Right	App. Total	Left	Thru	Right	App. Total	
07:15 AM	5	115	5	125	32	14	17	63	3	103	4	110	7	10	2	19	317
07:30 AM	4	123	6	133	43	19	16	78	1	132	8	141	14	9	2	25	377
07:45 AM	4	143	9	156	45	11	8	64	2	106	27	135	8	11	6	25	380
08:00 AM	1	116	10	127	18	18	13	49	2	89	24	115	4	12	2	18	309
Total Volume	14	497	30	541	138	62	54	254	8	430	63	501	33	42	12	87	1383
% App. Total	2.6	91.9	5.5		54.3	24.4	21.3		1.6	85.8	12.6		37.9	48.3	13.8		
PHF	.700	.869	.750	.867	.767	.816	.794	.814	.667	.814	.583	.888	.589	.875	.500	.870	.910

Peak Hour Analysis From 07:00 AM to 08:45 AM - Peak 1 of 1
 Peak Hour for Entire Intersection Begins at 07:15 AM

City of Imperial
 N/S: SR-86
 E/W: Neckel Road
 Weather: Clear

File Name : 04_IPL_SR-86_Neckel AM
 Site Code : 99921570
 Start Date : 10/13/2021
 Page No : 2

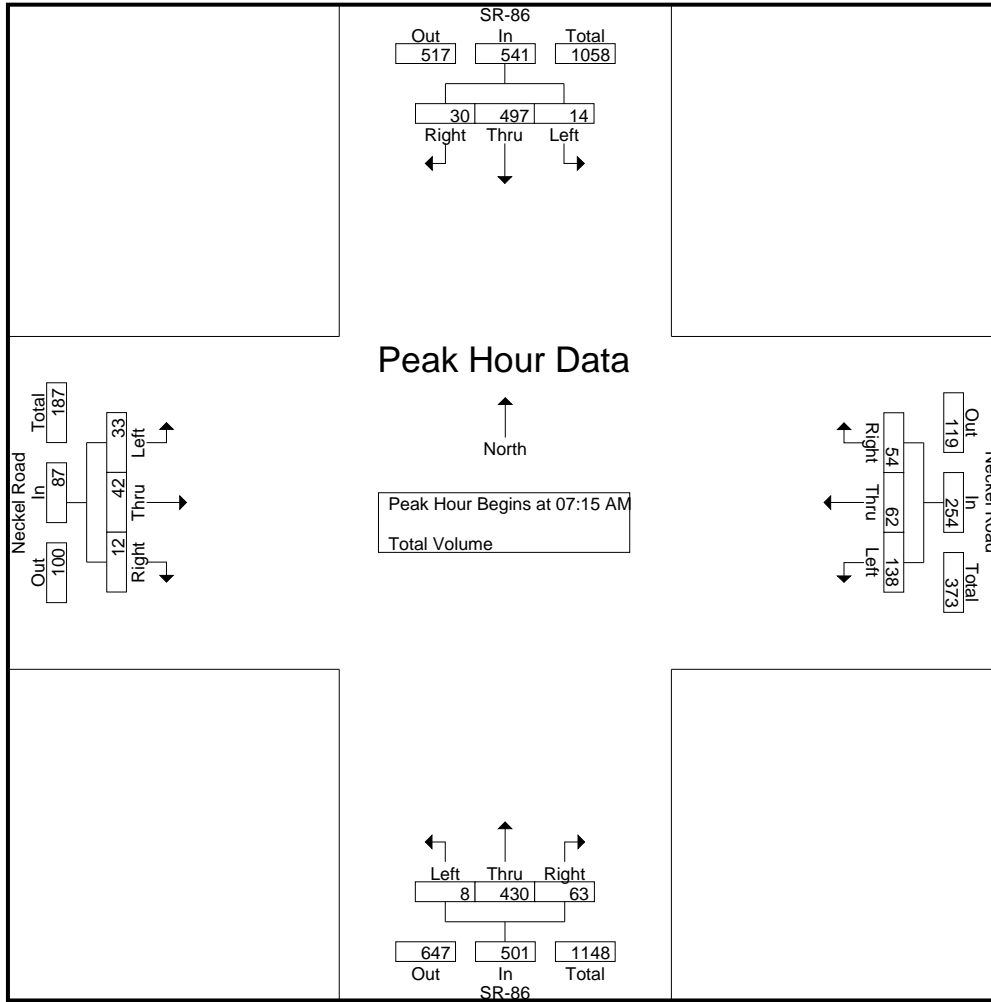

Peak Hour Analysis From 07:00 AM to 08:45 AM - Peak 1 of 1
 Peak Hour for Each Approach Begins at:

	07:15 AM				07:15 AM				07:15 AM				07:00 AM			
+0 mins.	5	115	5	125	32	14	17	63	3	103	4	110	9	7	2	18
+15 mins.	4	123	6	133	43	19	16	78	1	132	8	141	7	10	2	19
+30 mins.	4	143	9	156	45	11	8	64	2	106	27	135	14	9	2	25
+45 mins.	1	116	10	127	18	18	13	49	2	89	24	115	8	11	6	25
Total Volume	14	497	30	541	138	62	54	254	8	430	63	501	38	37	12	87
% App. Total	2.6	91.9	5.5		54.3	24.4	21.3		1.6	85.8	12.6		43.7	42.5	13.8	
PHF	.700	.869	.750	.867	.767	.816	.794	.814	.667	.814	.583	.888	.679	.841	.500	.870

City of Imperial
 N/S: SR-86
 E/W: Neckel Road
 Weather: Clear

File Name : 04_IPL_SR-86_Neckel PM
 Site Code : 99921570
 Start Date : 10/13/2021
 Page No : 1

Groups Printed- Total Volume

Start Time	SR-86 Southbound				Neckel Road Westbound				SR-86 Northbound				Neckel Road Eastbound				Int. Total
	Left	Thru	Right	App. Total	Left	Thru	Right	App. Total	Left	Thru	Right	App. Total	Left	Thru	Right	App. Total	
04:00 PM	7	131	8	146	23	8	16	47	4	109	20	133	0	11	3	14	340
04:15 PM	10	121	8	139	12	6	10	28	3	128	21	152	3	5	2	10	329
04:30 PM	7	114	11	132	8	4	10	22	5	113	18	136	0	12	3	15	305
04:45 PM	6	116	9	131	12	8	8	28	2	120	20	142	3	8	0	11	312
Total	30	482	36	548	55	26	44	125	14	470	79	563	6	36	8	50	1286
05:00 PM	9	130	5	144	19	5	7	31	4	132	12	148	2	5	0	7	330
05:15 PM	6	145	10	161	19	4	12	35	2	134	19	155	5	11	3	19	370
05:30 PM	8	106	9	123	16	5	15	36	3	140	29	172	3	4	0	7	338
05:45 PM	5	101	3	109	26	5	11	42	2	134	21	157	2	5	1	8	316
Total	28	482	27	537	80	19	45	144	11	540	81	632	12	25	4	41	1354
Grand Total	58	964	63	1085	135	45	89	269	25	1010	160	1195	18	61	12	91	2640
Apprch %	5.3	88.8	5.8		50.2	16.7	33.1		2.1	84.5	13.4		19.8	67	13.2		
Total %	2.2	36.5	2.4	41.1	5.1	1.7	3.4	10.2	0.9	38.3	6.1	45.3	0.7	2.3	0.5	3.4	

Start Time	SR-86 Southbound				Neckel Road Westbound				SR-86 Northbound				Neckel Road Eastbound				Int. Total
	Left	Thru	Right	App. Total	Left	Thru	Right	App. Total	Left	Thru	Right	App. Total	Left	Thru	Right	App. Total	
05:00 PM	9	130	5	144	19	5	7	31	4	132	12	148	2	5	0	7	330
05:15 PM	6	145	10	161	19	4	12	35	2	134	19	155	5	11	3	19	370
05:30 PM	8	106	9	123	16	5	15	36	3	140	29	172	3	4	0	7	338
05:45 PM	5	101	3	109	26	5	11	42	2	134	21	157	2	5	1	8	316
Total Volume	28	482	27	537	80	19	45	144	11	540	81	632	12	25	4	41	1354
% App. Total	5.2	89.8	5		55.6	13.2	31.2		1.7	85.4	12.8		29.3	61	9.8		
PHF	.778	.831	.675	.834	.769	.950	.750	.857	.688	.964	.698	.919	.600	.568	.333	.539	.915

Peak Hour Analysis From 04:00 PM to 05:45 PM - Peak 1 of 1
 Peak Hour for Entire Intersection Begins at 05:00 PM

City of Imperial
 N/S: SR-86
 E/W: Neckel Road
 Weather: Clear

File Name : 04_IPL_SR-86_Neckel PM
 Site Code : 99921570
 Start Date : 10/13/2021
 Page No : 2

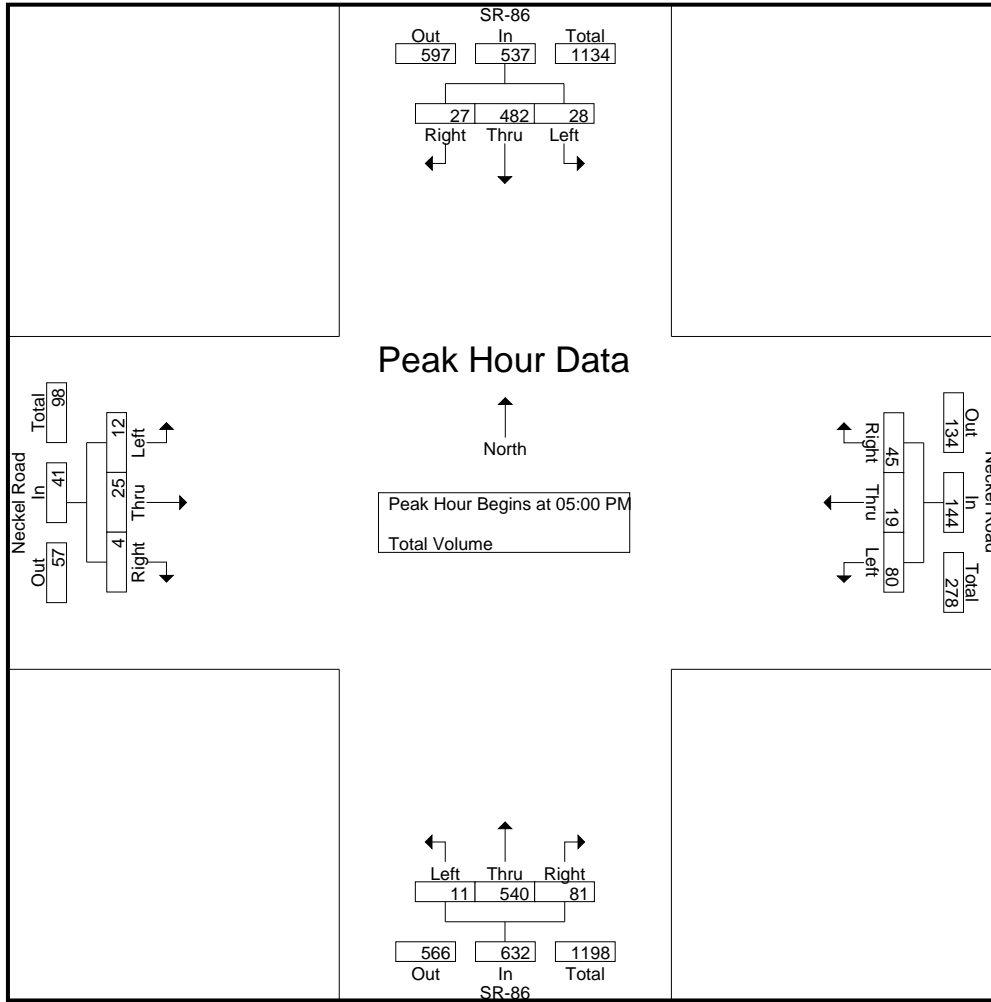

Peak Hour Analysis From 04:00 PM to 05:45 PM - Peak 1 of 1
 Peak Hour for Each Approach Begins at:

	04:30 PM				05:00 PM				05:00 PM				04:30 PM			
+0 mins.	7	114	11	132	19	5	7	31	4	132	12	148	0	12	3	15
+15 mins.	6	116	9	131	19	4	12	35	2	134	19	155	3	8	0	11
+30 mins.	9	130	5	144	16	5	15	36	3	140	29	172	2	5	0	7
+45 mins.	6	145	10	161	26	5	11	42	2	134	21	157	5	11	3	19
Total Volume	28	505	35	568	80	19	45	144	11	540	81	632	10	36	6	52
% App. Total	4.9	88.9	6.2		55.6	13.2	31.2		1.7	85.4	12.8		19.2	69.2	11.5	
PHF	.778	.871	.795	.882	.769	.950	.750	.857	.688	.964	.698	.919	.500	.750	.500	.684

City of Imperial
 N/S: La Brucherie Road
 E/W: Neckel Road
 Weather: Clear

File Name : 05_IPL_La B_Neckel AM
 Site Code : 99921570
 Start Date : 10/13/2021
 Page No : 1

Groups Printed- Total Volume

Start Time	La Brucherie Road Southbound				Neckel Road Westbound				La Brucherie Road Northbound				Neckel Road Eastbound				Int. Total
	Left	Thru	Right	App. Total	Left	Thru	Right	App. Total	Left	Thru	Right	App. Total	Left	Thru	Right	App. Total	
07:00 AM	0	0	0	0	3	15	0	18	1	3	7	11	1	9	0	10	39
07:15 AM	0	0	1	1	6	14	1	21	0	1	7	8	0	13	1	14	44
07:30 AM	0	1	0	1	16	14	0	30	2	0	9	11	2	16	11	29	71
07:45 AM	0	0	0	0	14	6	0	20	1	2	16	19	1	9	8	18	57
Total	0	1	1	2	39	49	1	89	4	6	39	49	4	47	20	71	211
08:00 AM	0	0	1	1	12	14	0	26	3	0	9	12	1	8	1	10	49
08:15 AM	1	1	0	2	16	9	0	25	1	4	7	12	0	7	2	9	48
08:30 AM	0	1	0	1	1	7	0	8	0	1	3	4	1	6	3	10	23
08:45 AM	0	0	0	0	1	2	2	5	1	1	1	3	1	3	3	7	15
Total	1	2	1	4	30	32	2	64	5	6	20	31	3	24	9	36	135
Grand Total	1	3	2	6	69	81	3	153	9	12	59	80	7	71	29	107	346
Apprch %	16.7	50	33.3		45.1	52.9	2		11.2	15	73.8		6.5	66.4	27.1		
Total %	0.3	0.9	0.6	1.7	19.9	23.4	0.9	44.2	2.6	3.5	17.1	23.1	2	20.5	8.4	30.9	

Start Time	La Brucherie Road Southbound				Neckel Road Westbound				La Brucherie Road Northbound				Neckel Road Eastbound				Int. Total
	Left	Thru	Right	App. Total	Left	Thru	Right	App. Total	Left	Thru	Right	App. Total	Left	Thru	Right	App. Total	
07:30 AM	0	1	0	1	16	14	0	30	2	0	9	11	2	16	11	29	71
07:45 AM	0	0	0	0	14	6	0	20	1	2	16	19	1	9	8	18	57
08:00 AM	0	0	1	1	12	14	0	26	3	0	9	12	1	8	1	10	49
08:15 AM	1	1	0	2	16	9	0	25	1	4	7	12	0	7	2	9	48
Total Volume	1	2	1	4	58	43	0	101	7	6	41	54	4	40	22	66	225
% App. Total	25	50	25		57.4	42.6	0		13	11.1	75.9		6.1	60.6	33.3		
PHF	.250	.500	.250	.500	.906	.768	.000	.842	.583	.375	.641	.711	.500	.625	.500	.569	.792

Peak Hour Analysis From 07:00 AM to 08:45 AM - Peak 1 of 1
 Peak Hour for Entire Intersection Begins at 07:30 AM

City of Imperial
 N/S: La Brucherie Road
 E/W: Neckel Road
 Weather: Clear

File Name : 05_IPL_La B_Neckel AM
 Site Code : 99921570
 Start Date : 10/13/2021
 Page No : 2

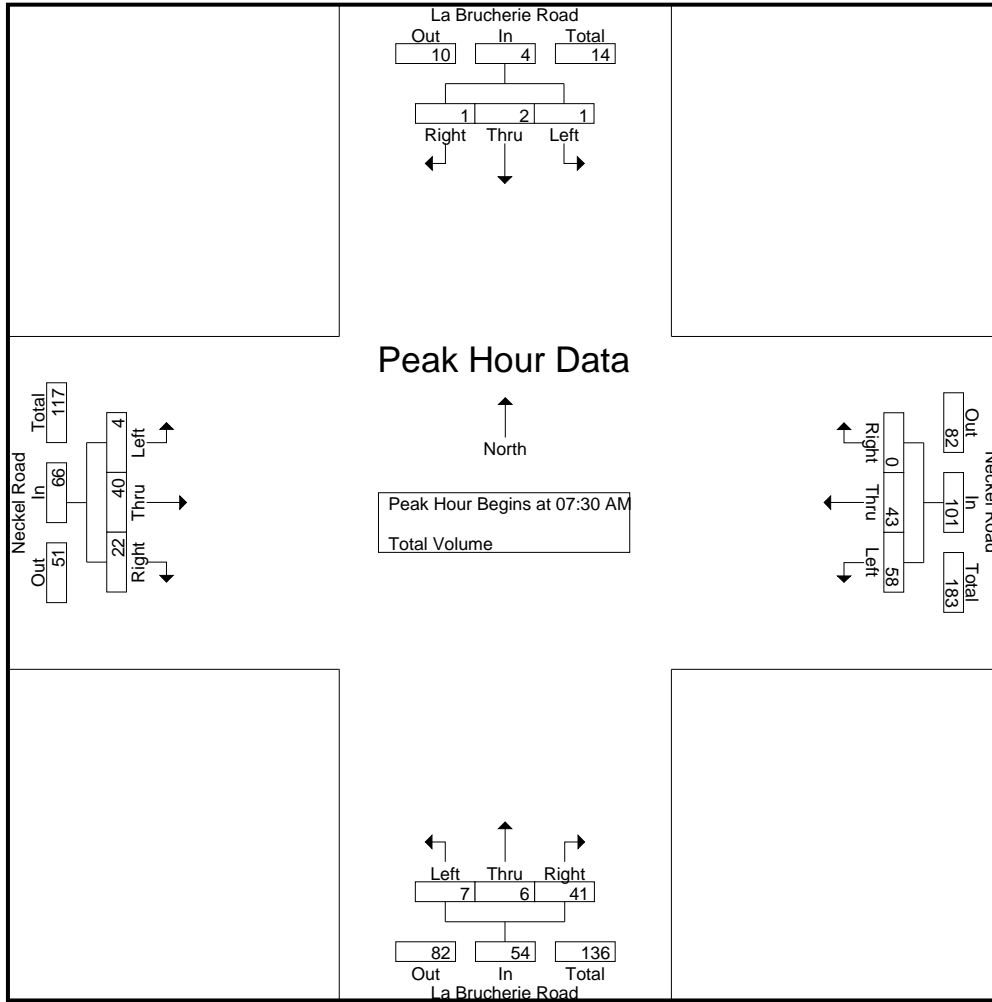

Peak Hour Analysis From 07:00 AM to 08:45 AM - Peak 1 of 1
 Peak Hour for Each Approach Begins at:

	07:30 AM				07:30 AM				07:30 AM				07:00 AM			
+0 mins.	0	1	0	1	16	14	0	30	2	0	9	11	1	9	0	10
+15 mins.	0	0	0	0	14	6	0	20	1	2	16	19	0	13	1	14
+30 mins.	0	0	1	1	12	14	0	26	3	0	9	12	2	16	11	29
+45 mins.	1	1	0	2	16	9	0	25	1	4	7	12	1	9	8	18
Total Volume	1	2	1	4	58	43	0	101	7	6	41	54	4	47	20	71
% App. Total	25	50	25		57.4	42.6	0		13	11.1	75.9		5.6	66.2	28.2	
PHF	.250	.500	.250	.500	.906	.768	.000	.842	.583	.375	.641	.711	.500	.734	.455	.612

City of Imperial
 N/S: La Brucherie Road
 E/W: Neckel Road
 Weather: Clear

File Name : 05_IPL_La B_Neckel PM
 Site Code : 99921570
 Start Date : 10/13/2021
 Page No : 1

Groups Printed- Total Volume

Start Time	La Brucherie Road Southbound				Neckel Road Westbound				La Brucherie Road Northbound				Neckel Road Eastbound				Int. Total
	Left	Thru	Right	App. Total	Left	Thru	Right	App. Total	Left	Thru	Right	App. Total	Left	Thru	Right	App. Total	
04:00 PM	0	0	2	2	9	8	0	17	1	0	1	2	1	13	3	17	38
04:15 PM	0	0	2	2	2	11	0	13	1	1	3	5	1	6	2	9	29
04:30 PM	0	1	1	2	6	14	1	21	3	3	3	9	0	13	1	14	46
04:45 PM	0	4	2	6	5	10	0	15	0	2	3	5	0	5	2	7	33
Total	0	5	7	12	22	43	1	66	5	6	10	21	2	37	8	47	146
05:00 PM	0	2	0	2	3	11	0	14	1	1	3	5	0	5	0	5	26
05:15 PM	0	2	0	2	4	10	0	14	2	4	4	10	0	11	2	13	39
05:30 PM	0	4	0	4	4	11	0	15	1	1	2	4	1	5	2	8	31
05:45 PM	1	0	2	3	4	7	0	11	1	1	1	3	0	6	2	8	25
Total	1	8	2	11	15	39	0	54	5	7	10	22	1	27	6	34	121
Grand Total	1	13	9	23	37	82	1	120	10	13	20	43	3	64	14	81	267
Apprch %	4.3	56.5	39.1		30.8	68.3	0.8		23.3	30.2	46.5		3.7	79	17.3		
Total %	0.4	4.9	3.4	8.6	13.9	30.7	0.4	44.9	3.7	4.9	7.5	16.1	1.1	24	5.2	30.3	

Start Time	La Brucherie Road Southbound				Neckel Road Westbound				La Brucherie Road Northbound				Neckel Road Eastbound				Int. Total
	Left	Thru	Right	App. Total	Left	Thru	Right	App. Total	Left	Thru	Right	App. Total	Left	Thru	Right	App. Total	
04:00 PM	0	0	2	2	9	8	0	17	1	0	1	2	1	13	3	17	38
04:15 PM	0	0	2	2	2	11	0	13	1	1	3	5	1	6	2	9	29
04:30 PM	0	1	1	2	6	14	1	21	3	3	3	9	0	13	1	14	46
04:45 PM	0	4	2	6	5	10	0	15	0	2	3	5	0	5	2	7	33
Total Volume	0	5	7	12	22	43	1	66	5	6	10	21	2	37	8	47	146
% App. Total	0	41.7	58.3		33.3	65.2	1.5		23.8	28.6	47.6		4.3	78.7	17		
PHF	.000	.313	.875	.500	.611	.768	.250	.786	.417	.500	.833	.583	.500	.712	.667	.691	.793

Peak Hour Analysis From 04:00 PM to 05:45 PM - Peak 1 of 1
 Peak Hour for Entire Intersection Begins at 04:00 PM

City of Imperial
 N/S: La Brucherie Road
 E/W: Neckel Road
 Weather: Clear

File Name : 05_IPL_La B_Neckel PM
 Site Code : 99921570
 Start Date : 10/13/2021
 Page No : 2

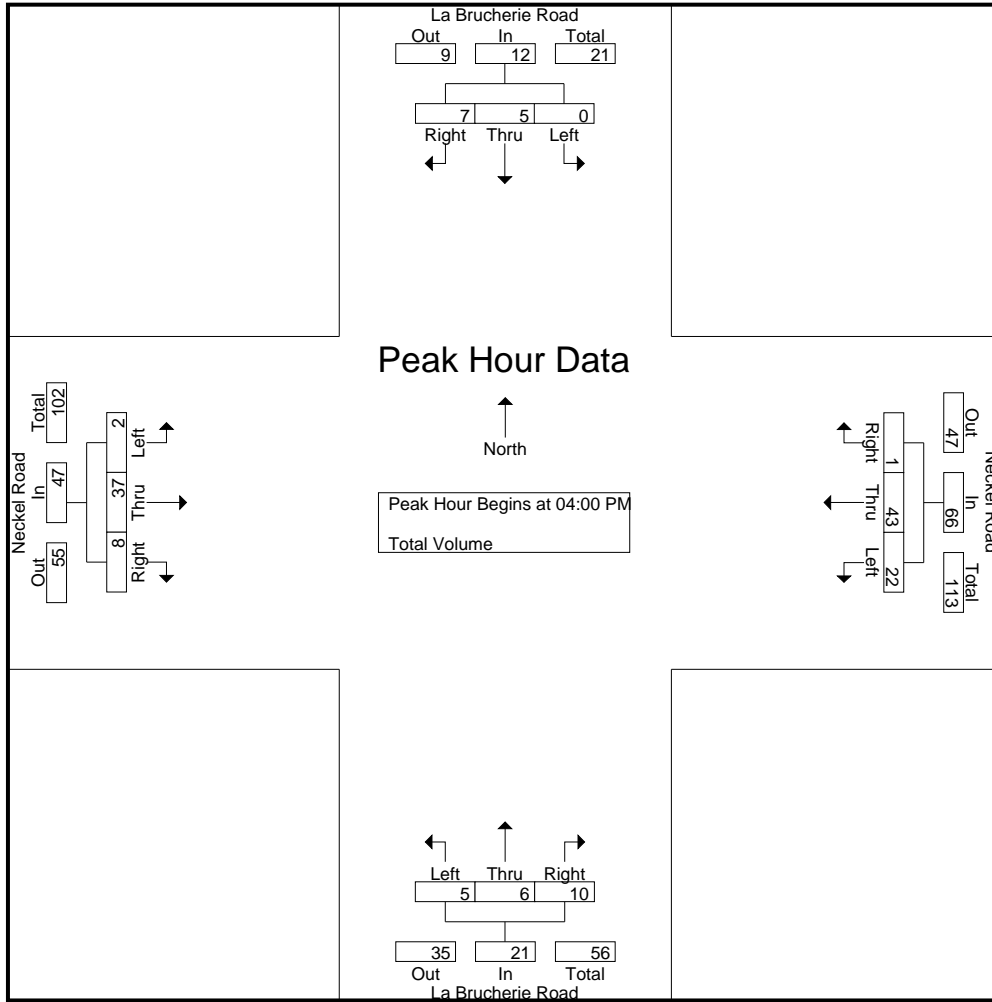

Peak Hour Analysis From 04:00 PM to 05:45 PM - Peak 1 of 1
 Peak Hour for Each Approach Begins at:

	04:45 PM				04:00 PM				04:30 PM				04:00 PM			
+0 mins.	0	4	2	6	9	8	0	17	3	3	3	9	1	13	3	17
+15 mins.	0	2	0	2	2	11	0	13	0	2	3	5	1	6	2	9
+30 mins.	0	2	0	2	6	14	1	21	1	1	3	5	0	13	1	14
+45 mins.	0	4	0	4	5	10	0	15	2	4	4	10	0	5	2	7
Total Volume	0	12	2	14	22	43	1	66	6	10	13	29	2	37	8	47
% App. Total	0	85.7	14.3		33.3	65.2	1.5		20.7	34.5	44.8		4.3	78.7	17	
PHF	.000	.750	.250	.583	.611	.768	.250	.786	.500	.625	.813	.725	.500	.712	.667	.691

City of Imperial
 N/S: SR-86
 E/W: Worthington Road/Barioni Boulevard
 Weather: Clear

File Name : 06_IPL_SR-86_Worthington AM
 Site Code : 99921570
 Start Date : 10/13/2021
 Page No : 1

Groups Printed- Total Volume

Start Time	SR-86 Southbound				Barioni Boulevard Westbound				SR-86 Northbound				Worthington Road Eastbound				Int. Total
	Left	Thru	Right	App. Total	Left	Thru	Right	App. Total	Left	Thru	Right	App. Total	Left	Thru	Right	App. Total	
07:00 AM	5	75	13	93	4	12	8	24	8	77	9	94	9	27	21	57	268
07:15 AM	6	130	11	147	8	17	20	45	13	95	18	126	10	22	34	66	384
07:30 AM	13	182	13	208	22	30	15	67	20	136	17	173	17	39	46	102	550
07:45 AM	8	162	8	178	8	33	25	66	22	140	13	175	21	30	59	110	529
Total	32	549	45	626	42	92	68	202	63	448	57	568	57	118	160	335	1731
08:00 AM	9	141	18	168	16	47	12	75	29	86	11	126	19	29	59	107	476
08:15 AM	8	128	15	151	7	18	23	48	19	90	8	117	11	34	42	87	403
08:30 AM	7	125	9	141	6	12	9	27	13	95	9	117	6	20	34	60	345
08:45 AM	5	122	7	134	7	16	7	30	8	89	5	102	5	14	19	38	304
Total	29	516	49	594	36	93	51	180	69	360	33	462	41	97	154	292	1528
Grand Total	61	1065	94	1220	78	185	119	382	132	808	90	1030	98	215	314	627	3259
Apprch %	5	87.3	7.7		20.4	48.4	31.2		12.8	78.4	8.7		15.6	34.3	50.1		
Total %	1.9	32.7	2.9	37.4	2.4	5.7	3.7	11.7	4.1	24.8	2.8	31.6	3	6.6	9.6	19.2	

Start Time	SR-86 Southbound				Barioni Boulevard Westbound				SR-86 Northbound				Worthington Road Eastbound				Int. Total
	Left	Thru	Right	App. Total	Left	Thru	Right	App. Total	Left	Thru	Right	App. Total	Left	Thru	Right	App. Total	
Peak Hour Analysis From 07:00 AM to 08:45 AM - Peak 1 of 1																	
Peak Hour for Entire Intersection Begins at 07:30 AM																	
07:30 AM	13	182	13	208	22	30	15	67	20	136	17	173	17	39	46	102	550
07:45 AM	8	162	8	178	8	33	25	66	22	140	13	175	21	30	59	110	529
08:00 AM	9	141	18	168	16	47	12	75	29	86	11	126	19	29	59	107	476
08:15 AM	8	128	15	151	7	18	23	48	19	90	8	117	11	34	42	87	403
Total Volume	38	613	54	705	53	128	75	256	90	452	49	591	68	132	206	406	1958
% App. Total	5.4	87	7.7		20.7	50	29.3		15.2	76.5	8.3		16.7	32.5	50.7		
PHF	.731	.842	.750	.847	.602	.681	.750	.853	.776	.807	.721	.844	.810	.846	.873	.923	.890

City of Imperial
 N/S: SR-86
 E/W: Worthington Road/Barioni Boulevard
 Weather: Clear

File Name : 06_IPL_SR-86_Worthington AM
 Site Code : 99921570
 Start Date : 10/13/2021
 Page No : 2

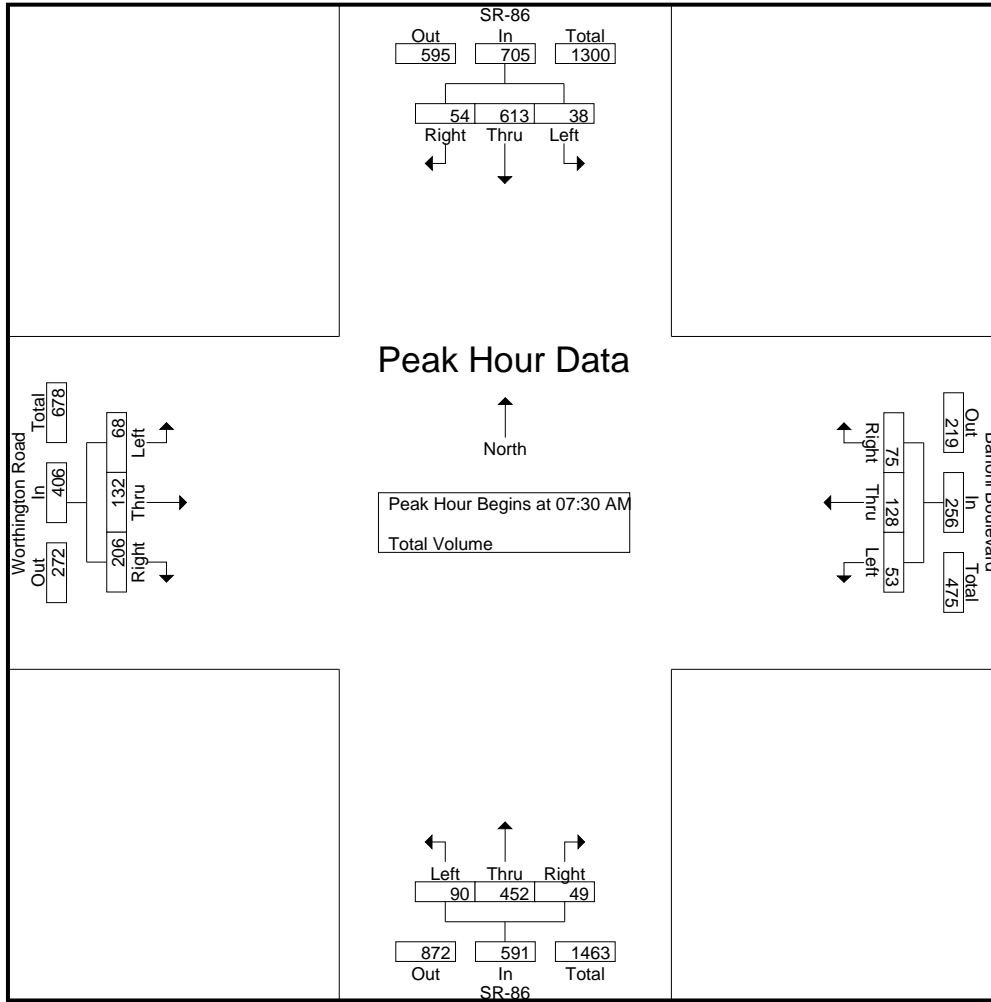

Peak Hour Analysis From 07:00 AM to 08:45 AM - Peak 1 of 1
 Peak Hour for Each Approach Begins at:

	07:30 AM				07:30 AM				07:15 AM				07:30 AM			
+0 mins.	13	182	13	208	22	30	15	67	13	95	18	126	17	39	46	102
+15 mins.	8	162	8	178	8	33	25	66	20	136	17	173	21	30	59	110
+30 mins.	9	141	18	168	16	47	12	75	22	140	13	175	19	29	59	107
+45 mins.	8	128	15	151	7	18	23	48	29	86	11	126	11	34	42	87
Total Volume	38	613	54	705	53	128	75	256	84	457	59	600	68	132	206	406
% App. Total	5.4	87	7.7		20.7	50	29.3		14	76.2	9.8		16.7	32.5	50.7	
PHF	.731	.842	.750	.847	.602	.681	.750	.853	.724	.816	.819	.857	.810	.846	.873	.923

City of Imperial
 N/S: SR-86
 E/W: Worthington Road/Barioni Boulevard
 Weather: Clear

File Name : 06_IPL_SR-86_Worthington PM
 Site Code : 99921570
 Start Date : 10/13/2021
 Page No : 1

Groups Printed- Total Volume

Start Time	SR-86 Southbound				Barioni Boulevard Westbound				SR-86 Northbound				Worthington Road Eastbound				Int. Total
	Left	Thru	Right	App. Total	Left	Thru	Right	App. Total	Left	Thru	Right	App. Total	Left	Thru	Right	App. Total	
04:00 PM	10	146	6	162	9	34	17	60	20	145	5	170	9	18	27	54	446
04:15 PM	4	124	9	137	10	30	13	53	17	155	4	176	8	21	31	60	426
04:30 PM	4	136	8	148	17	33	5	55	17	135	7	159	9	19	22	50	412
04:45 PM	10	118	11	139	4	31	7	42	29	147	2	178	9	21	29	59	418
Total	28	524	34	586	40	128	42	210	83	582	18	683	35	79	109	223	1702
05:00 PM	4	149	8	161	8	34	8	50	20	167	8	195	13	19	28	60	466
05:15 PM	6	186	25	217	15	27	19	61	31	163	2	196	7	18	17	42	516
05:30 PM	10	122	12	144	19	28	8	55	32	158	1	191	11	17	31	59	449
05:45 PM	6	120	16	142	11	20	15	46	26	160	3	189	16	18	26	60	437
Total	26	577	61	664	53	109	50	212	109	648	14	771	47	72	102	221	1868
Grand Total	54	1101	95	1250	93	237	92	422	192	1230	32	1454	82	151	211	444	3570
Apprch %	4.3	88.1	7.6		22	56.2	21.8		13.2	84.6	2.2		18.5	34	47.5		
Total %	1.5	30.8	2.7	35	2.6	6.6	2.6	11.8	5.4	34.5	0.9	40.7	2.3	4.2	5.9	12.4	

Start Time	SR-86 Southbound				Barioni Boulevard Westbound				SR-86 Northbound				Worthington Road Eastbound				Int. Total
	Left	Thru	Right	App. Total	Left	Thru	Right	App. Total	Left	Thru	Right	App. Total	Left	Thru	Right	App. Total	
05:00 PM	4	149	8	161	8	34	8	50	20	167	8	195	13	19	28	60	466
05:15 PM	6	186	25	217	15	27	19	61	31	163	2	196	7	18	17	42	516
05:30 PM	10	122	12	144	19	28	8	55	32	158	1	191	11	17	31	59	449
05:45 PM	6	120	16	142	11	20	15	46	26	160	3	189	16	18	26	60	437
Total Volume	26	577	61	664	53	109	50	212	109	648	14	771	47	72	102	221	1868
% App. Total	3.9	86.9	9.2		25	51.4	23.6		14.1	84	1.8		21.3	32.6	46.2		
PHF	.650	.776	.610	.765	.697	.801	.658	.869	.852	.970	.438	.983	.734	.947	.823	.921	.905

Peak Hour Analysis From 04:00 PM to 05:45 PM - Peak 1 of 1
 Peak Hour for Entire Intersection Begins at 05:00 PM

City of Imperial
 N/S: SR-86
 E/W: Worthington Road/Barioni Boulevard
 Weather: Clear

File Name : 06_IPL_SR-86_Worthington PM
 Site Code : 99921570
 Start Date : 10/13/2021
 Page No : 2

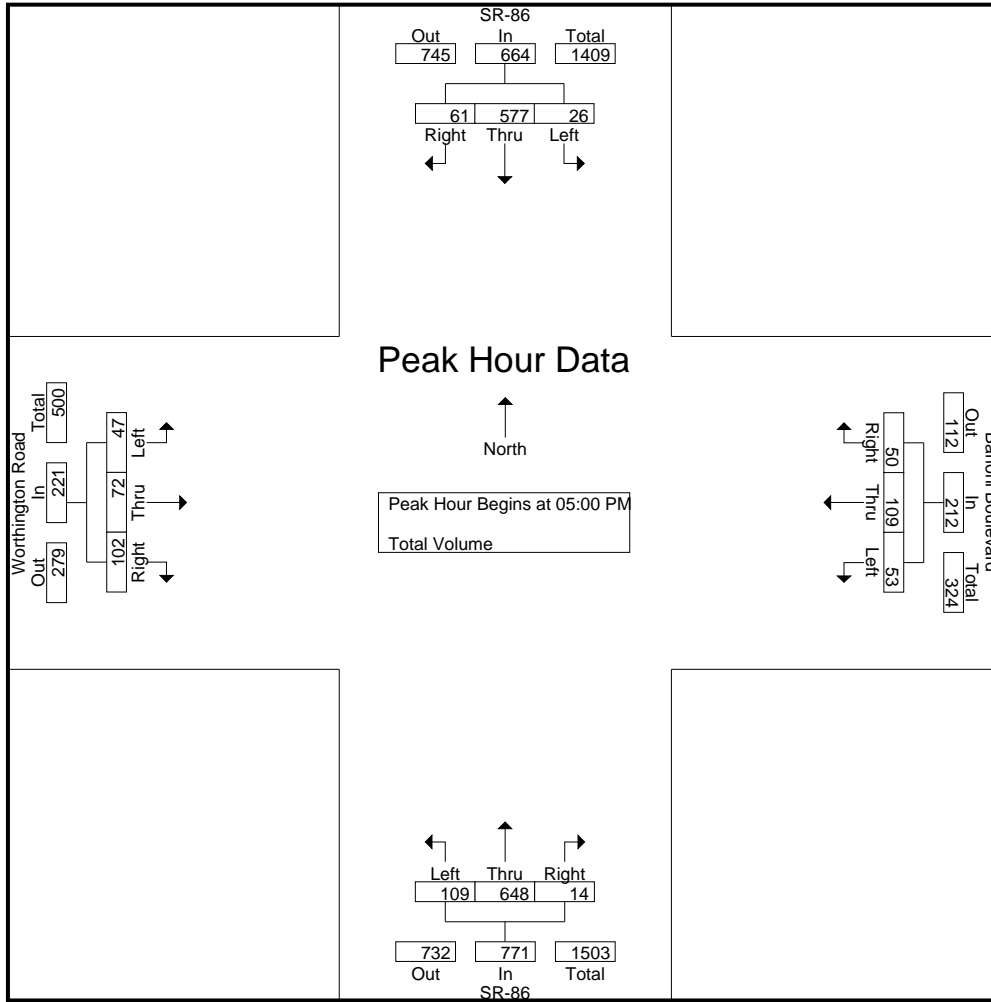

Peak Hour Analysis From 04:00 PM to 05:45 PM - Peak 1 of 1
 Peak Hour for Each Approach Begins at:

	04:30 PM				05:00 PM				05:00 PM				04:15 PM			
+0 mins.	4	136	8	148	8	34	8	50	20	167	8	195	8	21	31	60
+15 mins.	10	118	11	139	15	27	19	61	31	163	2	196	9	19	22	50
+30 mins.	4	149	8	161	19	28	8	55	32	158	1	191	9	21	29	59
+45 mins.	6	186	25	217	11	20	15	46	26	160	3	189	13	19	28	60
Total Volume	24	589	52	665	53	109	50	212	109	648	14	771	39	80	110	229
% App. Total	3.6	88.6	7.8		25	51.4	23.6		14.1	84	1.8		17	34.9	48	
PHF	.600	.792	.520	.766	.697	.801	.658	.869	.852	.970	.438	.983	.750	.952	.887	.954

City of Imperial
 N/S: La Brucherie Road/B Street
 E/W: Worthington Road
 Weather: Clear

File Name : 07_IPL_La B_Worthington AM
 Site Code : 99921570
 Start Date : 10/13/2021
 Page No : 1

Groups Printed- Total Volume

Start Time	La Brucherie Road Southbound				Worthington Road Westbound				B Street Northbound				Worthington Road Eastbound				Int. Total
	Left	Thru	Right	App. Total	Left	Thru	Right	App. Total	Left	Thru	Right	App. Total	Left	Thru	Right	App. Total	
07:00 AM	10	1	4	15	0	33	7	40	0	0	0	0	6	52	3	61	116
07:15 AM	12	4	5	21	2	31	5	38	0	0	0	0	9	59	9	77	136
07:30 AM	29	10	11	50	1	50	18	69	0	0	0	0	20	99	45	164	283
07:45 AM	29	16	15	60	2	89	26	117	0	0	1	1	13	99	52	164	342
Total	80	31	35	146	5	203	56	264	0	0	1	1	48	309	109	466	877
08:00 AM	13	3	16	32	4	86	16	106	0	0	0	0	13	85	18	116	254
08:15 AM	32	1	20	53	4	68	15	87	0	0	0	0	13	96	1	110	250
08:30 AM	3	0	4	7	1	25	2	28	0	0	0	0	5	30	0	35	70
08:45 AM	5	0	7	12	0	26	7	33	0	0	0	0	1	32	0	33	78
Total	53	4	47	104	9	205	40	254	0	0	0	0	32	243	19	294	652
Grand Total	133	35	82	250	14	408	96	518	0	0	1	1	80	552	128	760	1529
Apprch %	53.2	14	32.8		2.7	78.8	18.5		0	0	100		10.5	72.6	16.8		
Total %	8.7	2.3	5.4	16.4	0.9	26.7	6.3	33.9	0	0	0.1	0.1	5.2	36.1	8.4	49.7	

Start Time	La Brucherie Road Southbound				Worthington Road Westbound				B Street Northbound				Worthington Road Eastbound				Int. Total
	Left	Thru	Right	App. Total	Left	Thru	Right	App. Total	Left	Thru	Right	App. Total	Left	Thru	Right	App. Total	
07:30 AM	29	10	11	50	1	50	18	69	0	0	0	0	20	99	45	164	283
07:45 AM	29	16	15	60	2	89	26	117	0	0	1	1	13	99	52	164	342
08:00 AM	13	3	16	32	4	86	16	106	0	0	0	0	13	85	18	116	254
08:15 AM	32	1	20	53	4	68	15	87	0	0	0	0	13	96	1	110	250
Total Volume	103	30	62	195	11	293	75	379	0	0	1	1	59	379	116	554	1129
% App. Total	52.8	15.4	31.8		2.9	77.3	19.8		0	0	100		10.6	68.4	20.9		
PHF	.805	.469	.775	.813	.688	.823	.721	.810	.000	.000	.250	.250	.738	.957	.558	.845	.825

Peak Hour Analysis From 07:00 AM to 08:45 AM - Peak 1 of 1
 Peak Hour for Entire Intersection Begins at 07:30 AM

City of Imperial
 N/S: La Brucherie Road/B Street
 E/W: Worthington Road
 Weather: Clear

File Name : 07_IPL_La B_Worthington AM
 Site Code : 99921570
 Start Date : 10/13/2021
 Page No : 2

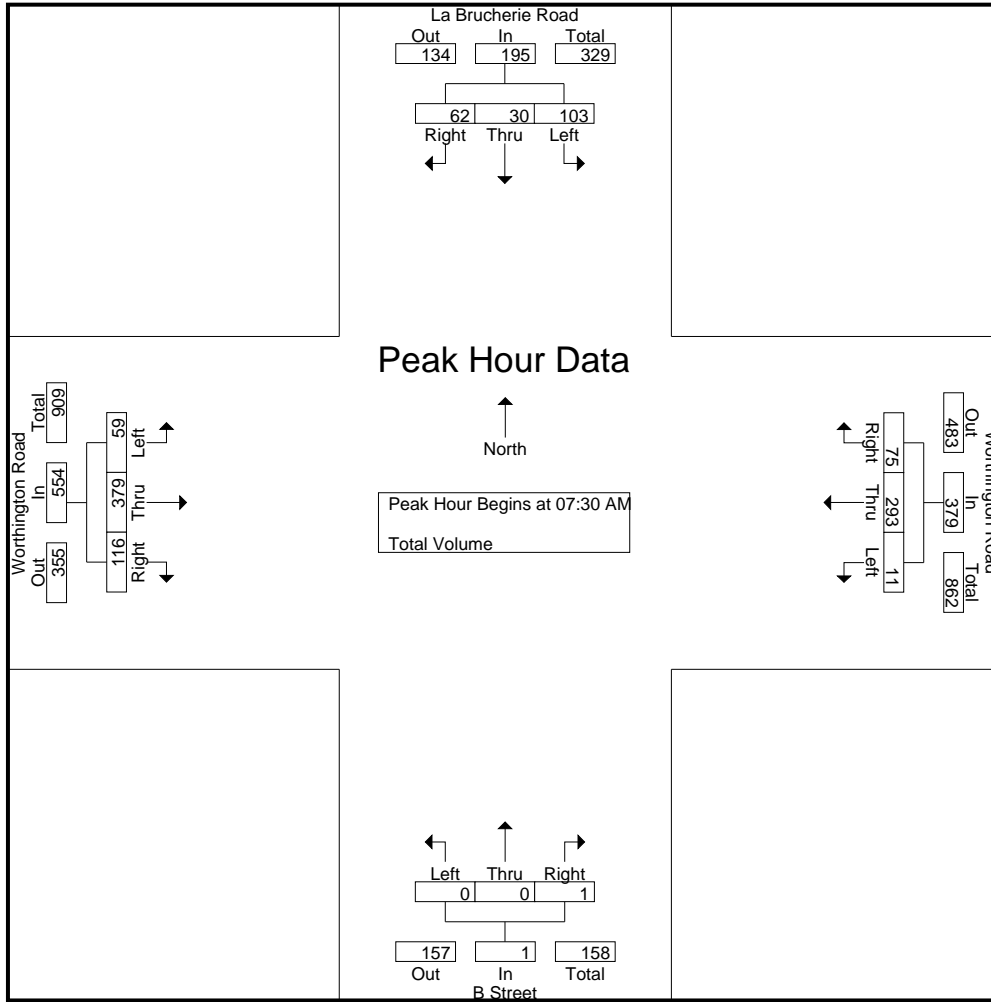

Peak Hour Analysis From 07:00 AM to 08:45 AM - Peak 1 of 1
 Peak Hour for Each Approach Begins at:

	07:30 AM				07:30 AM				07:00 AM				07:30 AM			
+0 mins.	29	10	11	50	1	50	18	69	0	0	0	0	20	99	45	164
+15 mins.	29	16	15	60	2	89	26	117	0	0	0	0	13	99	52	164
+30 mins.	13	3	16	32	4	86	16	106	0	0	0	0	13	85	18	116
+45 mins.	32	1	20	53	4	68	15	87	0	0	1	1	13	96	1	110
Total Volume	103	30	62	195	11	293	75	379	0	0	1	1	59	379	116	554
% App. Total	52.8	15.4	31.8		2.9	77.3	19.8		0	0	100		10.6	68.4	20.9	
PHF	.805	.469	.775	.813	.688	.823	.721	.810	.000	.000	.250	.250	.738	.957	.558	.845

City of Imperial
 N/S: La Brucherie Road/B Street
 E/W: Worthington Road
 Weather: Clear

File Name : 07_IPL_La B_Worthington PM
 Site Code : 99921570
 Start Date : 10/13/2021
 Page No : 1

Groups Printed- Total Volume

Start Time	La Brucherie Road Southbound				Worthington Road Westbound				B Street Northbound				Worthington Road Eastbound				Int. Total
	Left	Thru	Right	App. Total	Left	Thru	Right	App. Total	Left	Thru	Right	App. Total	Left	Thru	Right	App. Total	
04:00 PM	13	2	6	21	0	41	9	50	0	0	0	0	4	38	1	43	114
04:15 PM	6	0	5	11	0	40	7	47	0	0	0	0	11	36	0	47	105
04:30 PM	3	0	2	5	3	42	8	53	0	0	0	0	6	27	1	34	92
04:45 PM	8	1	7	16	1	50	7	58	0	0	0	0	5	46	1	52	126
Total	30	3	20	53	4	173	31	208	0	0	0	0	26	147	3	176	437
05:00 PM	11	1	3	15	0	50	7	57	0	0	0	0	5	33	3	41	113
05:15 PM	4	1	5	10	6	57	4	67	0	0	0	0	6	44	15	65	142
05:30 PM	15	2	7	24	8	61	12	81	0	0	0	0	8	57	8	73	178
05:45 PM	6	1	8	15	12	41	10	63	1	0	0	1	6	48	6	60	139
Total	36	5	23	64	26	209	33	268	1	0	0	1	25	182	32	239	572
Grand Total	66	8	43	117	30	382	64	476	1	0	0	1	51	329	35	415	1009
Apprch %	56.4	6.8	36.8		6.3	80.3	13.4		100	0	0		12.3	79.3	8.4		
Total %	6.5	0.8	4.3	11.6	3	37.9	6.3	47.2	0.1	0	0	0.1	5.1	32.6	3.5	41.1	

Start Time	La Brucherie Road Southbound				Worthington Road Westbound				B Street Northbound				Worthington Road Eastbound				Int. Total
	Left	Thru	Right	App. Total	Left	Thru	Right	App. Total	Left	Thru	Right	App. Total	Left	Thru	Right	App. Total	
Peak Hour Analysis From 04:00 PM to 05:45 PM - Peak 1 of 1																	
Peak Hour for Entire Intersection Begins at 05:00 PM																	
05:00 PM	11	1	3	15	0	50	7	57	0	0	0	0	5	33	3	41	113
05:15 PM	4	1	5	10	6	57	4	67	0	0	0	0	6	44	15	65	142
05:30 PM	15	2	7	24	8	61	12	81	0	0	0	0	8	57	8	73	178
05:45 PM	6	1	8	15	12	41	10	63	1	0	0	1	6	48	6	60	139
Total Volume	36	5	23	64	26	209	33	268	1	0	0	1	25	182	32	239	572
% App. Total	56.2	7.8	35.9		9.7	78	12.3		100	0	0		10.5	76.2	13.4		
PHF	.600	.625	.719	.667	.542	.857	.688	.827	.250	.000	.000	.250	.781	.798	.533	.818	.803

City of Imperial
 N/S: La Brucherie Road/B Street
 E/W: Worthington Road
 Weather: Clear

File Name : 07_IPL_La B_Worthington PM
 Site Code : 99921570
 Start Date : 10/13/2021
 Page No : 2

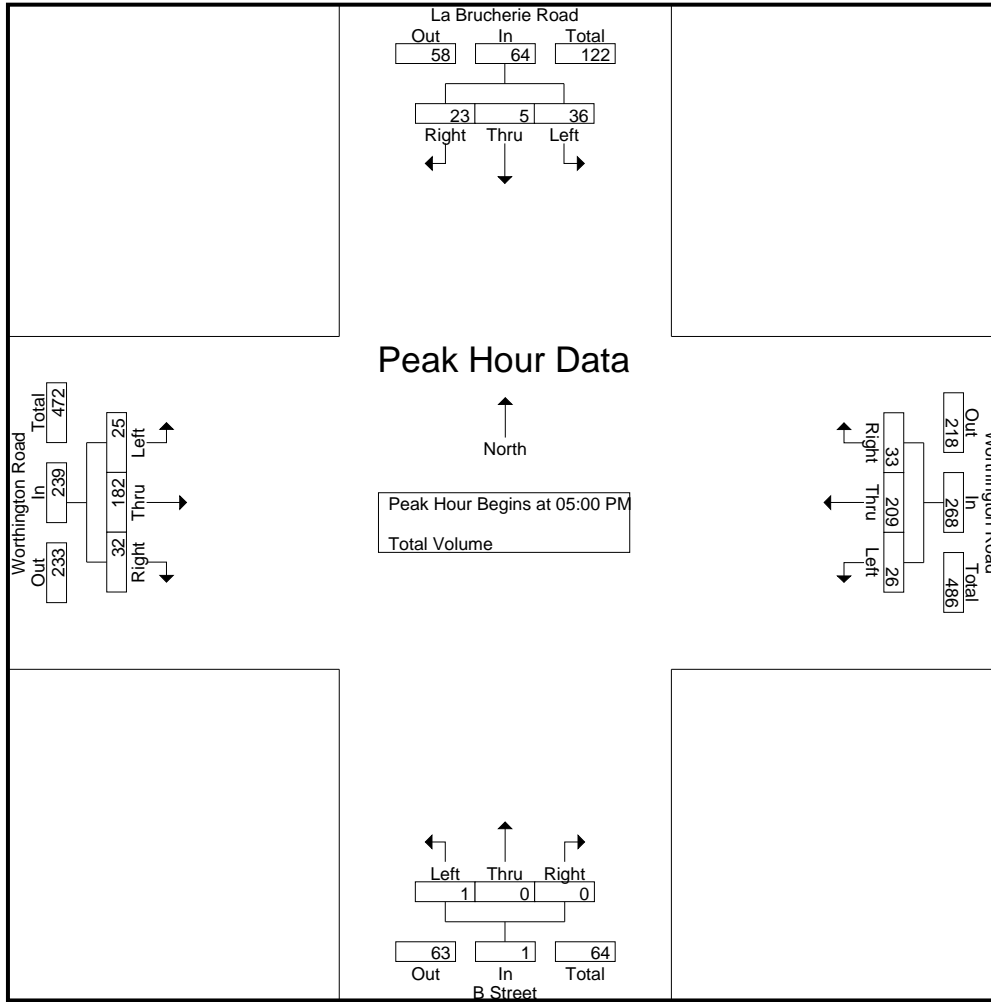

Peak Hour Analysis From 04:00 PM to 05:45 PM - Peak 1 of 1
 Peak Hour for Each Approach Begins at:

	04:45 PM				05:00 PM				05:00 PM				05:00 PM			
+0 mins.	8	1	7	16	0	50	7	57	0	0	0	0	5	33	3	41
+15 mins.	11	1	3	15	6	57	4	67	0	0	0	0	6	44	15	65
+30 mins.	4	1	5	10	8	61	12	81	0	0	0	0	8	57	8	73
+45 mins.	15	2	7	24	12	41	10	63	1	0	0	1	6	48	6	60
Total Volume	38	5	22	65	26	209	33	268	1	0	0	1	25	182	32	239
% App. Total	58.5	7.7	33.8		9.7	78	12.3		100	0	0		10.5	76.2	13.4	
PHF	.633	.625	.786	.677	.542	.857	.688	.827	.250	.000	.000	.250	.781	.798	.533	.818

City of Imperial
 N/S: SR-86 (Imperial Avenue)
 E/W: Aten Road
 Weather: Clear

File Name : 08_IPL_SR-86_Aten AM
 Site Code : 99921570
 Start Date : 10/13/2021
 Page No : 1

Groups Printed- Total Volume

Start Time	SR-86 Southbound				Aten Road Westbound				SR-86 Northbound				Aten Road Eastbound				Int. Total
	Left	Thru	Right	App. Total	Left	Thru	Right	App. Total	Left	Thru	Right	App. Total	Left	Thru	Right	App. Total	
07:00 AM	13	69	31	113	21	32	30	83	3	61	11	75	27	44	11	82	353
07:15 AM	26	99	42	167	14	55	32	101	9	73	8	90	50	67	11	128	486
07:30 AM	28	170	93	291	21	80	40	141	7	102	11	120	65	87	10	162	714
07:45 AM	39	185	123	347	21	95	44	160	13	83	20	116	54	102	14	170	793
Total	106	523	289	918	77	262	146	485	32	319	50	401	196	300	46	542	2346
08:00 AM	40	158	88	286	45	71	23	139	20	81	15	116	46	72	19	137	678
08:15 AM	31	139	61	231	40	45	30	115	19	68	19	106	16	67	18	101	553
08:30 AM	20	121	35	176	36	40	25	101	13	92	27	132	37	47	12	96	505
08:45 AM	25	122	34	181	30	50	18	98	18	83	20	121	26	49	11	86	486
Total	116	540	218	874	151	206	96	453	70	324	81	475	125	235	60	420	2222
Grand Total	222	1063	507	1792	228	468	242	938	102	643	131	876	321	535	106	962	4568
Apprch %	12.4	59.3	28.3		24.3	49.9	25.8		11.6	73.4	15		33.4	55.6	11		
Total %	4.9	23.3	11.1	39.2	5	10.2	5.3	20.5	2.2	14.1	2.9	19.2	7	11.7	2.3	21.1	

Start Time	SR-86 Southbound				Aten Road Westbound				SR-86 Northbound				Aten Road Eastbound				Int. Total
	Left	Thru	Right	App. Total	Left	Thru	Right	App. Total	Left	Thru	Right	App. Total	Left	Thru	Right	App. Total	
Peak Hour Analysis From 07:00 AM to 08:45 AM - Peak 1 of 1																	
Peak Hour for Entire Intersection Begins at 07:30 AM																	
07:30 AM	28	170	93	291	21	80	40	141	7	102	11	120	65	87	10	162	714
07:45 AM	39	185	123	347	21	95	44	160	13	83	20	116	54	102	14	170	793
08:00 AM	40	158	88	286	45	71	23	139	20	81	15	116	46	72	19	137	678
08:15 AM	31	139	61	231	40	45	30	115	19	68	19	106	16	67	18	101	553
Total Volume	138	652	365	1155	127	291	137	555	59	334	65	458	181	328	61	570	2738
% App. Total	11.9	56.5	31.6		22.9	52.4	24.7		12.9	72.9	14.2		31.8	57.5	10.7		
PHF	.863	.881	.742	.832	.706	.766	.778	.867	.738	.819	.813	.954	.696	.804	.803	.838	.863

City of Imperial
 N/S: SR-86 (Imperial Avenue)
 E/W: Aten Road
 Weather: Clear

File Name : 08_IPL_SR-86_Aten AM
 Site Code : 99921570
 Start Date : 10/13/2021
 Page No : 2

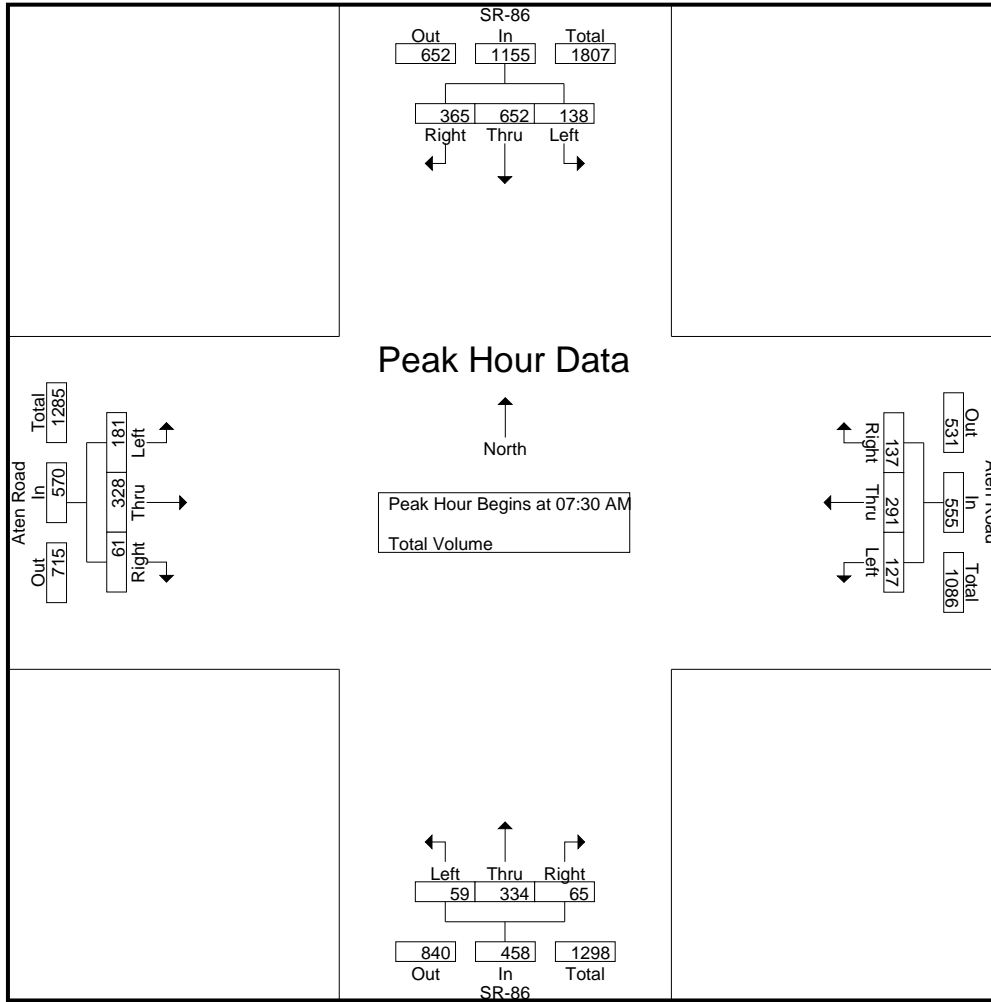

Peak Hour Analysis From 07:00 AM to 08:45 AM - Peak 1 of 1
 Peak Hour for Each Approach Begins at:

	07:30 AM				07:30 AM				08:00 AM				07:15 AM			
+0 mins.	28	170	93	291	21	80	40	141	20	81	15	116	50	67	11	128
+15 mins.	39	185	123	347	21	95	44	160	19	68	19	106	65	87	10	162
+30 mins.	40	158	88	286	45	71	23	139	13	92	27	132	54	102	14	170
+45 mins.	31	139	61	231	40	45	30	115	18	83	20	121	46	72	19	137
Total Volume	138	652	365	1155	127	291	137	555	70	324	81	475	215	328	54	597
% App. Total	11.9	56.5	31.6		22.9	52.4	24.7		14.7	68.2	17.1		36	54.9	9	
PHF	.863	.881	.742	.832	.706	.766	.778	.867	.875	.880	.750	.900	.827	.804	.711	.878

City of Imperial
 N/S: SR-86 (Imperial Avenue)
 E/W: Aten Road
 Weather: Clear

File Name : 08_IPL_SR-86_Aten PM
 Site Code : 99921570
 Start Date : 10/13/2021
 Page No : 1

Groups Printed- Total Volume

Start Time	SR-86 Southbound				Aten Road Westbound				SR-86 Northbound				Aten Road Eastbound				Int. Total
	Left	Thru	Right	App. Total	Left	Thru	Right	App. Total	Left	Thru	Right	App. Total	Left	Thru	Right	App. Total	
04:00 PM	24	139	38	201	44	74	26	144	14	156	35	205	47	62	21	130	680
04:15 PM	30	126	28	184	33	79	18	130	23	148	31	202	28	56	18	102	618
04:30 PM	16	127	32	175	48	69	26	143	11	125	33	169	48	60	23	131	618
04:45 PM	24	130	30	184	35	67	28	130	18	141	32	191	46	62	11	119	624
Total	94	522	128	744	160	289	98	547	66	570	131	767	169	240	73	482	2540
05:00 PM	22	109	63	194	42	68	23	133	24	142	43	209	49	80	20	149	685
05:15 PM	29	141	56	226	50	87	35	172	14	170	31	215	46	66	21	133	746
05:30 PM	34	143	54	231	46	58	33	137	20	193	39	252	43	60	14	117	737
05:45 PM	30	112	52	194	34	57	35	126	12	145	32	189	38	61	9	108	617
Total	115	505	225	845	172	270	126	568	70	650	145	865	176	267	64	507	2785
Grand Total	209	1027	353	1589	332	559	224	1115	136	1220	276	1632	345	507	137	989	5325
Apprch %	13.2	64.6	22.2		29.8	50.1	20.1		8.3	74.8	16.9		34.9	51.3	13.9		
Total %	3.9	19.3	6.6	29.8	6.2	10.5	4.2	20.9	2.6	22.9	5.2	30.6	6.5	9.5	2.6	18.6	

Start Time	SR-86 Southbound				Aten Road Westbound				SR-86 Northbound				Aten Road Eastbound				Int. Total
	Left	Thru	Right	App. Total	Left	Thru	Right	App. Total	Left	Thru	Right	App. Total	Left	Thru	Right	App. Total	
Peak Hour Analysis From 04:00 PM to 05:45 PM - Peak 1 of 1																	
Peak Hour for Entire Intersection Begins at 04:45 PM																	
04:45 PM	24	130	30	184	35	67	28	130	18	141	32	191	46	62	11	119	624
05:00 PM	22	109	63	194	42	68	23	133	24	142	43	209	49	80	20	149	685
05:15 PM	29	141	56	226	50	87	35	172	14	170	31	215	46	66	21	133	746
05:30 PM	34	143	54	231	46	58	33	137	20	193	39	252	43	60	14	117	737
Total Volume	109	523	203	835	173	280	119	572	76	646	145	867	184	268	66	518	2792
% App. Total	13.1	62.6	24.3		30.2	49	20.8		8.8	74.5	16.7		35.5	51.7	12.7		
PHF	.801	.914	.806	.904	.865	.805	.850	.831	.792	.837	.843	.860	.939	.838	.786	.869	.936

City of Imperial
 N/S: SR-86 (Imperial Avenue)
 E/W: Aten Road
 Weather: Clear

File Name : 08_IPL_SR-86_Aten PM
 Site Code : 99921570
 Start Date : 10/13/2021
 Page No : 2

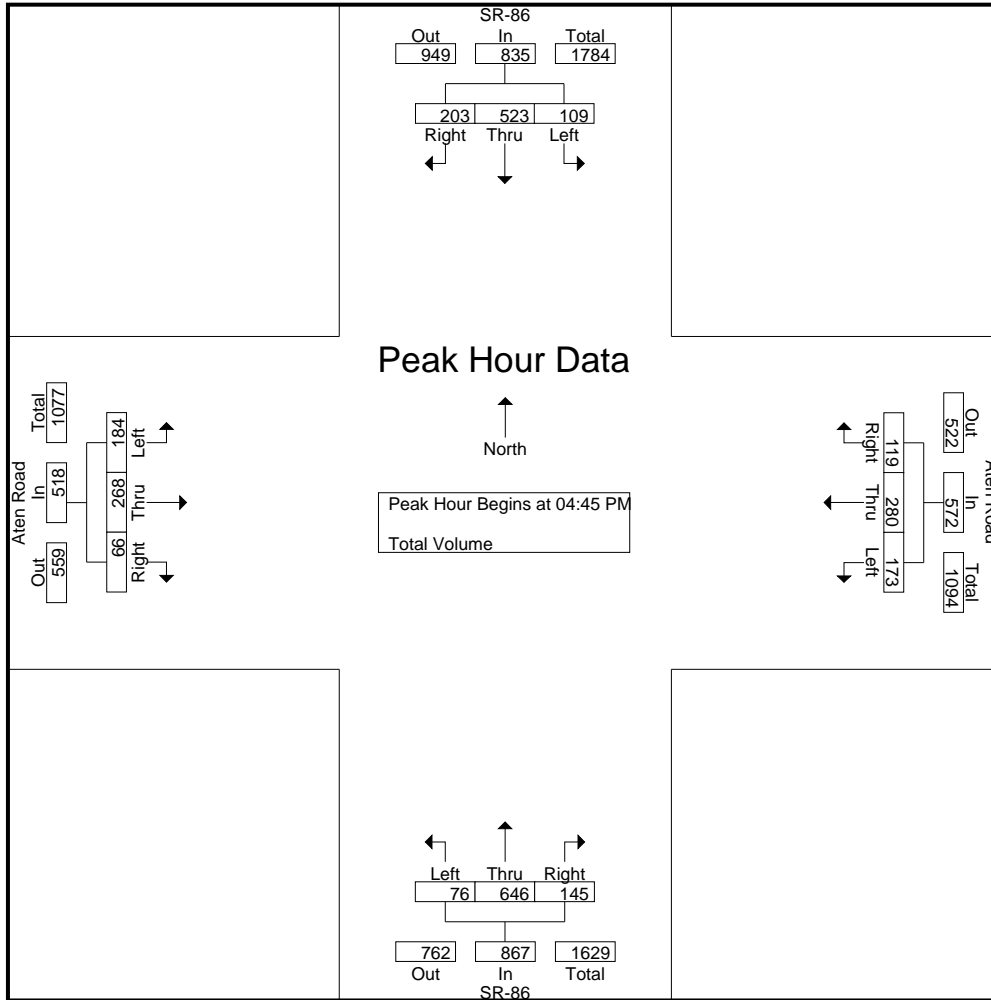

Peak Hour Analysis From 04:00 PM to 05:45 PM - Peak 1 of 1
 Peak Hour for Each Approach Begins at:

	05:00 PM				04:30 PM				04:45 PM				04:30 PM			
+0 mins.	22	109	63	194	48	69	26	143	18	141	32	191	48	60	23	131
+15 mins.	29	141	56	226	35	67	28	130	24	142	43	209	46	62	11	119
+30 mins.	34	143	54	231	42	68	23	133	14	170	31	215	49	80	20	149
+45 mins.	30	112	52	194	50	87	35	172	20	193	39	252	46	66	21	133
Total Volume	115	505	225	845	175	291	112	578	76	646	145	867	189	268	75	532
% App. Total	13.6	59.8	26.6		30.3	50.3	19.4		8.8	74.5	16.7		35.5	50.4	14.1	
PHF	.846	.883	.893	.915	.875	.836	.800	.840	.792	.837	.843	.860	.964	.838	.815	.893

Counts Unlimited, Inc.

City of Imperial
 La Brucherie Road
 B/ Ralph Road - Neckel Road
 24 Hour Directional Volume Count

PO Box 1178
 Corona, CA 92878
 Phone: (951) 268-6268
 email: counts@countsunlimited.com

IPL002
 Site Code: 999-21570

Start Time	13-Oct-21 Wed	Northbound		Hour Totals		Southbound		Hour Totals		Combined Totals	
		Morning	Afternoon	Morning	Afternoon	Morning	Afternoon	Morning	Afternoon	Morning	Afternoon
12:00		0	4			0	1				
12:15		0	3			0	1				
12:30		0	5			0	2				
12:45		0	4	0	16	0	3	0	7	0	23
01:00		0	1			0	2				
01:15		0	3			0	3				
01:30		1	3			0	1				
01:45		0	2	1	9	0	1	0	7	1	16
02:00		1	4			0	2				
02:15		0	2			0	2				
02:30		0	2			1	2				
02:45		0	3	1	11	0	3	1	9	2	20
03:00		0	2			0	1				
03:15		0	3			0	2				
03:30		2	2			0	2				
03:45		0	1	2	8	0	5	0	10	2	18
04:00		0	1			0	2				
04:15		0	2			0	2				
04:30		0	4			0	2				
04:45		0	2	0	9	0	6	0	12	0	21
05:00		0	1			0	2				
05:15		2	4			0	2				
05:30		3	2			1	4				
05:45		3	1	8	8	5	3	6	11	14	19
06:00		1	2			2	3				
06:15		4	2			1	1				
06:30		3	1			0	2				
06:45		4	1	12	6	0	0	3	6	15	12
07:00		4	0			0	1				
07:15		2	0			1	2				
07:30		2	1			1	0				
07:45		3	2	11	3	0	0	2	3	13	6
08:00		1	1			1	0				
08:15		4	0			2	0				
08:30		2	1			1	0				
08:45		4	0	11	2	0	0	4	0	15	2
09:00		4	2			1	1				
09:15		3	0			1	0				
09:30		2	1			2	0				
09:45		2	1	11	4	0	0	4	1	15	5
10:00		2	1			1	1				
10:15		4	3			0	0				
10:30		2	1			1	0				
10:45		3	0	11	5	0	0	2	1	13	6
11:00		5	1			1	0				
11:15		2	0			2	0				
11:30		2	0			2	0				
11:45		0	1	9	2	0	0	5	0	14	2
Total		77	83	77	83	27	67	27	67	104	150
Combined Total		160		160		94		94		254	
AM Peak	-	06:15	-	-	-	05:30	-	-	-	-	-
Vol.	-	15	-	-	-	9	-	-	-	-	-
P.H.F.	-	0.938	-	-	-	0.450	-	-	-	-	-
PM Peak	-	-	12:00	-	-	-	04:45	-	-	-	-
Vol.	-	-	16	-	-	-	14	-	-	-	-
P.H.F.	-	-	0.800	-	-	-	0.583	-	-	-	-
Percentage		48.1%	51.9%			28.7%	71.3%				
ADT/AADT		ADT 254	AADT 254								

Counts Unlimited, Inc.

City of Imperial
 Ralph Road
 B/ State Route 86 - Clark Road
 24 Hour Directional Volume Count

PO Box 1178
 Corona, CA 92878
 Phone: (951) 268-6268
 email: counts@countsunlimited.com

IPL003
 Site Code: 999-21570

Start Time	13-Oct-21 Wed	Eastbound		Hour Totals		Westbound		Hour Totals		Combined Totals	
		Morning	Afternoon	Morning	Afternoon	Morning	Afternoon	Morning	Afternoon	Morning	Afternoon
12:00		0	13			2	10				
12:15		0	5			0	13				
12:30		0	10			0	13				
12:45		0	17	0	45	0	15	2	51	2	96
01:00		2	17			0	12				
01:15		2	13			0	9				
01:30		1	11			4	4				
01:45		1	15	6	56	1	8	5	33	11	89
02:00		0	9			0	14				
02:15		0	8			1	7				
02:30		0	14			0	13				
02:45		0	11	0	42	1	8	2	42	2	84
03:00		1	7			2	10				
03:15		0	15			0	14				
03:30		1	15			3	5				
03:45		0	15	2	52	3	10	8	39	10	91
04:00		1	13			0	12				
04:15		1	9			1	8				
04:30		1	16			1	16				
04:45		1	12	4	50	2	5	4	41	8	91
05:00		0	16			6	6				
05:15		7	18			9	9				
05:30		1	12			6	9				
05:45		2	8	10	54	12	10	33	34	43	88
06:00		1	10			11	7				
06:15		4	9			1	11				
06:30		6	16			8	6				
06:45		1	12	12	47	16	5	36	29	48	76
07:00		7	17			15	6				
07:15		13	12			15	9				
07:30		13	8			20	6				
07:45		11	14	44	51	26	3	76	24	120	75
08:00		22	8			18	4				
08:15		11	7			14	5				
08:30		7	6			8	1				
08:45		5	4	45	25	10	3	50	13	95	38
09:00		8	6			2	9				
09:15		8	3			9	7				
09:30		7	5			8	4				
09:45		6	5	29	19	7	5	26	25	55	44
10:00		3	2			4	1				
10:15		3	1			6	0				
10:30		6	2			5	1				
10:45		8	3	20	8	7	1	22	3	42	11
11:00		7	2			6	0				
11:15		9	0			10	1				
11:30		5	1			7	1				
11:45		7	0	28	3	5	3	28	5	56	8
Total		200	452	200	452	292	339	292	339	492	791
Combined Total		652		652		631		631		1283	
AM Peak	-	07:15	-	-	-	07:15	-	-	-	-	-
Vol.	-	59	-	-	-	79	-	-	-	-	-
P.H.F.		0.670				0.760					
PM Peak	-	-	04:30	-	-	-	00:15	-	-	-	-
Vol.	-	-	62	-	-	-	53	-	-	-	-
P.H.F.			0.861				0.883				
Percentage		30.7%	69.3%			46.3%	53.7%				
ADT/AADT		ADT 1,283		AADT 1,283							

Counts Unlimited, Inc.

City of Imperial
 State Route 86
 B/ Barioni Boulevard - Aten Road
 24 Hour Directional Volume Count

PO Box 1178
 Corona, CA 92878
 Phone: (951) 268-6268
 email: counts@countsunlimited.com

IPL006
 Site Code: 999-21570

Start Time	13-Oct-21 Wed	Northbound		Hour Totals		Southbound		Hour Totals		Combined Totals	
		Morning	Afternoon	Morning	Afternoon	Morning	Afternoon	Morning	Afternoon	Morning	Afternoon
12:00		21	175			12	183				
12:15		10	181			8	163				
12:30		8	183			5	219				
12:45		9	210	48	749	14	260	39	825	87	1574
01:00		12	195			7	214				
01:15		5	165			8	200				
01:30		6	206			5	175				
01:45		8	167	31	733	10	160	30	749	61	1482
02:00		7	183			7	154				
02:15		6	152			4	187				
02:30		6	155			8	195				
02:45		7	160	26	650	9	194	28	730	54	1380
03:00		6	150			6	188				
03:15		12	161			13	209				
03:30		10	147			10	212				
03:45		13	141	41	599	17	208	46	817	87	1416
04:00		10	170			9	182				
04:15		20	176			15	165				
04:30		26	159			14	175				
04:45		40	178	96	683	40	151	78	673	174	1356
05:00		47	195			33	185				
05:15		77	196			38	218				
05:30		65	191			63	172				
05:45		89	189	278	771	71	157	205	732	483	1503
06:00		58	169			68	138				
06:15		63	141			49	150				
06:30		90	144			79	149				
06:45		123	147	334	601	116	123	312	560	646	1161
07:00		94	147			100	123				
07:15		126	123			172	107				
07:30		173	121			250	126				
07:45		175	115	568	506	229	107	751	463	1319	969
08:00		126	108			216	71				
08:15		117	118			177	79				
08:30		117	109			165	80				
08:45		102	118	462	453	148	64	706	294	1168	747
09:00		103	104			126	51				
09:15		96	72			142	58				
09:30		95	80			148	64				
09:45		111	45	405	301	161	52	577	225	982	526
10:00		127	46			152	42				
10:15		92	46			162	46				
10:30		122	46			145	34				
10:45		130	39	471	177	161	18	620	140	1091	317
11:00		134	25			130	18				
11:15		146	21			179	19				
11:30		141	22			182	15				
11:45		172	19	593	87	161	19	652	71	1245	158
Total		3353	6310	3353	6310	4044	6279	4044	6279	7397	12589
Combined Total		9663		9663		10323		10323		19986	
AM Peak	-	07:15	-	-	-	07:30	-	-	-	-	-
Vol.	-	600	-	-	-	872	-	-	-	-	-
P.H.F.	-	0.857	-	-	-	0.872	-	-	-	-	-
PM Peak	-	-	00:45	-	-	-	00:30	-	-	-	-
Vol.	-	-	776	-	-	-	893	-	-	-	-
P.H.F.	-	-	0.924	-	-	-	0.859	-	-	-	-
Percentage		34.7%	65.3%			39.2%	60.8%				
ADT/AADT		ADT 19,986	AADT 19,986								

Counts Unlimited, Inc.

City of Imperial
 State Route 86
 B/ Keystone Road - Larsen Road
 24 Hour Directional Volume Count

PO Box 1178
 Corona, CA 92878
 Phone: (951) 268-6268
 email: counts@countsunlimited.com

IPL007
 Site Code: 999-21570

Start Time	13-Oct-21 Wed	Northbound		Hour Totals		Southbound		Hour Totals		Combined Totals	
		Morning	Afternoon	Morning	Afternoon	Morning	Afternoon	Morning	Afternoon	Morning	Afternoon
12:00		11	95			9	113				
12:15		11	118			7	98				
12:30		6	108			9	140				
12:45		10	127	38	448	11	133	36	484	74	932
01:00		9	127			5	114				
01:15		7	111			8	101				
01:30		6	152			4	112				
01:45		7	124	29	514	6	119	23	446	52	960
02:00		3	130			3	99				
02:15		6	129			6	143				
02:30		6	106			3	128				
02:45		8	125	23	490	9	152	21	522	44	1012
03:00		8	121			4	127				
03:15		11	102			10	156				
03:30		12	141			11	185				
03:45		14	112	45	476	12	142	37	610	82	1086
04:00		14	117			7	124				
04:15		16	133			12	134				
04:30		28	112			17	119				
04:45		29	146	87	508	26	156	62	533	149	1041
05:00		41	141			25	135				
05:15		71	145			30	168				
05:30		70	118			62	121				
05:45		67	157	249	561	68	79	185	503	434	1064
06:00		68	126			42	90				
06:15		72	94			45	102				
06:30		93	98			82	77				
06:45		124	110	357	428	75	90	244	359	601	787
07:00		103	83			90	67				
07:15		133	90			128	71				
07:30		128	71			137	63				
07:45		153	67	517	311	132	58	487	259	1004	570
08:00		79	73			130	52				
08:15		112	61			98	49				
08:30		88	62			95	46				
08:45		96	80	375	276	94	36	417	183	792	459
09:00		88	71			99	42				
09:15		93	62			95	40				
09:30		68	50			120	41				
09:45		82	36	331	219	97	27	411	150	742	369
10:00		89	28			113	32				
10:15		69	35			91	29				
10:30		99	31			111	18				
10:45		93	31	350	125	95	15	410	94	760	219
11:00		94	18			105	12				
11:15		122	13			107	22				
11:30		110	16			93	11				
11:45		118	13	444	60	104	14	409	59	853	119
Total		2845	4416	2845	4416	2742	4202	2742	4202	5587	8618
Combined Total		7261		7261		6944		6944		14205	
AM Peak	-	07:00	-	-	-	07:15	-	-	-	-	-
Vol.	-	517	-	-	-	527	-	-	-	-	-
P.H.F.	-	0.845	-	-	-	0.962	-	-	-	-	-
PM Peak	-	-	05:00	-	-	-	02:45	-	-	-	-
Vol.	-	-	561	-	-	-	620	-	-	-	-
P.H.F.	-	-	0.893	-	-	-	0.838	-	-	-	-
Percentage		39.2%	60.8%			39.5%	60.5%				
ADT/AADT		ADT 14,205	AADT 14,205								

Counts Unlimited, Inc.

City of Imperial
 State Route 86
 B/ Larsen Road - Ralph Road
 24 Hour Directional Volume Count

PO Box 1178
 Corona, CA 92878
 Phone: (951) 268-6268
 email: counts@countsunlimited.com

IPL004
 Site Code: 999-21570

Start Time	13-Oct-21 Wed	Northbound		Hour Totals		Southbound		Hour Totals		Combined Totals	
		Morning	Afternoon	Morning	Afternoon	Morning	Afternoon	Morning	Afternoon	Morning	Afternoon
12:00		11	102			9	112				
12:15		9	109			8	96				
12:30		6	111			7	131				
12:45		9	126	35	448	13	130	37	469	72	917
01:00		10	118			3	106				
01:15		8	111			9	103				
01:30		4	140			2	98				
01:45		7	118	29	487	7	110	21	417	50	904
02:00		5	134			3	97				
02:15		7	102			4	139				
02:30		4	107			5	121				
02:45		8	121	24	464	10	147	22	504	46	968
03:00		9	104			4	123				
03:15		12	102			6	155				
03:30		12	116			11	158				
03:45		12	115	45	437	15	173	36	609	81	1046
04:00		12	108			7	137				
04:15		19	133			8	131				
04:30		23	120			13	124				
04:45		33	119	87	480	28	131	56	523	143	1003
05:00		42	147			24	146				
05:15		71	138			27	159				
05:30		62	153			44	120				
05:45		79	143	254	581	67	95	162	520	416	1101
06:00		66	117			42	70				
06:15		73	96			35	109				
06:30		110	85			69	70				
06:45		123	94	372	392	67	67	213	316	585	708
07:00		96	78			67	67				
07:15		124	85			119	64				
07:30		142	65			137	59				
07:45		132	70	494	298	126	54	449	244	943	542
08:00		95	62			113	55				
08:15		94	56			92	46				
08:30		82	55			105	47				
08:45		101	75	372	248	87	33	397	181	769	429
09:00		77	60			88	39				
09:15		80	56			87	49				
09:30		65	45			113	39				
09:45		68	23	290	184	108	35	396	162	686	346
10:00		92	38			115	38				
10:15		66	24			85	29				
10:30		87	30			104	23				
10:45		86	23	331	115	98	15	402	105	733	220
11:00		90	16			109	12				
11:15		119	14			103	16				
11:30		92	18			100	17				
11:45		108	15	409	63	99	13	411	58	820	121
Total		2742	4197	2742	4197	2602	4108	2602	4108	5344	8305
Combined Total		6939		6939		6710		6710		13649	
AM Peak	-	07:00	-	-	-	07:15	-	-	-	-	-
Vol.	-	494	-	-	-	495	-	-	-	-	-
P.H.F.		0.870				0.903					
PM Peak	-	-	05:00	-	-	-	03:15	-	-	-	-
Vol.	-	-	581	-	-	-	623	-	-	-	-
P.H.F.			0.949				0.900				
Percentage		39.5%	60.5%			38.8%	61.2%				
ADT/AADT		ADT 13,649	AADT 13,649								

Counts Unlimited, Inc.

City of Imperial
 State Route 86
 B/ Neckel Road - Barioni Boulevard
 24 Hour Directional Volume Count

PO Box 1178
 Corona, CA 92878
 Phone: (951) 268-6268
 email: counts@countsunlimited.com

IPL005
 Site Code: 999-21570

Start Time	13-Oct-21 Wed	Northbound		Hour Totals		Southbound		Hour Totals		Combined Totals	
		Morning	Afternoon	Morning	Afternoon	Morning	Afternoon	Morning	Afternoon	Morning	Afternoon
12:00		21	167			14	144				
12:15		11	176			7	150				
12:30		8	187			4	193				
12:45		10	197	50	727	13	240	38	727	88	1454
01:00		10	181			7	180				
01:15		7	159			9	168				
01:30		6	189			7	154				
01:45		6	167	29	696	7	129	30	631	59	1327
02:00		7	169			5	131				
02:15		8	150			5	151				
02:30		3	152			6	167				
02:45		5	140	23	611	10	160	26	609	49	1220
03:00		5	130			5	158				
03:15		12	148			9	191				
03:30		13	149			12	195				
03:45		15	131	45	558	17	178	43	722	88	1280
04:00		9	171			10	162				
04:15		18	176			14	137				
04:30		28	149			16	148				
04:45		40	163	95	659	38	139	78	586	173	1245
05:00		47	188			29	161				
05:15		71	189			42	217				
05:30		59	177			51	144				
05:45		73	191	250	745	70	142	192	664	442	1409
06:00		54	166			58	112				
06:15		73	129			45	131				
06:30		79	125			77	135				
06:45		114	137	320	557	106	101	286	479	606	1036
07:00		94	124			93	98				
07:15		125	116			147	92				
07:30		168	104			208	95				
07:45		186	112	573	456	178	91	626	376	1199	832
08:00		117	106			168	67				
08:15		124	117			151	63				
08:30		110	114			141	64				
08:45		101	113	452	450	134	57	594	251	1046	701
09:00		106	97			111	51				
09:15		103	67			120	46				
09:30		78	76			133	66				
09:45		96	43	383	283	143	45	507	208	890	491
10:00		117	45			135	45				
10:15		85	41			139	36				
10:30		108	43			118	28				
10:45		118	34	428	163	139	18	531	127	959	290
11:00		123	20			113	16				
11:15		138	21			151	20				
11:30		139	23			151	18				
11:45		162	18	562	82	126	22	541	76	1103	158
Total		3210	5987	3210	5987	3492	5456	3492	5456	6702	11443
Combined Total		9197		9197		8948		8948		18145	
AM Peak	-	07:15	-	-	-	07:30	-	-	-	-	-
Vol.	-	596	-	-	-	705	-	-	-	-	-
P.H.F.	-	0.801	-	-	-	0.847	-	-	-	-	-
PM Peak	-	-	05:00	-	-	-	00:30	-	-	-	-
Vol.	-	-	745	-	-	-	781	-	-	-	-
P.H.F.	-	-	0.945	-	-	-	0.814	-	-	-	-
Percentage		34.9%	65.1%			39.0%	61.0%				
ADT/AADT		ADT 18,145	AADT 18,145								

Counts Unlimited, Inc.

City of Imperial
 State Route 86
 B/ Ralph Road - Neckel Road
 24 Hour Directional Volume Count

PO Box 1178
 Corona, CA 92878
 Phone: (951) 268-6268
 email: counts@countsunlimited.com

IPL001
 Site Code: 999-21570

Start Time	13-Oct-21 Wed	Northbound		Hour Totals		Southbound		Hour Totals		Combined Totals	
		Morning	Afternoon	Morning	Afternoon	Morning	Afternoon	Morning	Afternoon	Morning	Afternoon
12:00		11	106			11	113				
12:15		9	109			8	104				
12:30		6	112			7	135				
12:45		9	138	35	465	13	140	39	492	74	957
01:00		12	129			3	112				
01:15		9	121			8	109				
01:30		4	146			5	97				
01:45		6	123	31	519	6	108	22	426	53	945
02:00		5	137			3	105				
02:15		7	106			5	142				
02:30		4	116			5	129				
02:45		7	124	23	483	10	147	23	523	46	1006
03:00		9	104			5	126				
03:15		12	110			6	162				
03:30		11	126			12	158				
03:45		10	118	42	458	16	171	39	617	81	1075
04:00		13	114			7	142				
04:15		19	134			8	130				
04:30		23	122			13	126				
04:45		33	120	88	490	29	125	57	523	145	1013
05:00		39	151			27	140				
05:15		65	150			23	162				
05:30		56	155			43	119				
05:45		76	144	236	600	74	98	167	519	403	1119
06:00		61	124			47	74				
06:15		74	99			33	114				
06:30		109	95			70	70				
06:45		118	103	362	421	77	69	227	327	589	748
07:00		91	89			70	67				
07:15		125	91			122	67				
07:30		144	71			146	63				
07:45		133	80	493	331	142	53	480	250	973	581
08:00		109	67			123	56				
08:15		100	58			101	46				
08:30		82	60			106	47				
08:45		100	79	391	264	91	36	421	185	812	449
09:00		80	56			85	38				
09:15		82	54			90	51				
09:30		67	50			115	43				
09:45		70	23	299	183	111	35	401	167	700	350
10:00		91	39			115	38				
10:15		66	25			88	29				
10:30		89	31			105	23				
10:45		91	23	337	118	102	13	410	103	747	221
11:00		94	18			112	12				
11:15		123	13			108	16				
11:30		95	19			105	18				
11:45		109	14	421	64	98	15	423	61	844	125
Total		2758	4396	2758	4396	2709	4193	2709	4193	5467	8589
Combined Total		7154		7154		6902		6902		14056	
AM Peak	-	07:15	-	-	-	07:15	-	-	-	-	-
Vol.	-	511	-	-	-	533	-	-	-	-	-
P.H.F.	-	0.887	-	-	-	0.913	-	-	-	-	-
PM Peak	-	-	05:00	-	-	-	03:15	-	-	-	-
Vol.	-	-	600	-	-	-	633	-	-	-	-
P.H.F.	-	-	0.968	-	-	-	0.925	-	-	-	-
Percentage		38.6%	61.4%			39.2%	60.8%				
ADT/AADT		ADT 14,056	AADT 14,056								

Counts Unlimited, Inc.

City of Imperial
 State Route 86
 N/ Keystone Road
 24 Hour Directional Volume Count

PO Box 1178
 Corona, CA 92878
 Phone: (951) 268-6268
 email: counts@countsunlimited.com

IPL008
 Site Code: 999-21570

Start Time	13-Oct-21 Wed	Northbound		Hour Totals		Southbound		Hour Totals		Combined Totals	
		Morning	Afternoon	Morning	Afternoon	Morning	Afternoon	Morning	Afternoon	Morning	Afternoon
12:00		13	101			10	113				
12:15		13	125			7	100				
12:30		7	116			11	142				
12:45		10	121	43	463	11	141	39	496	82	959
01:00		10	132			6	122				
01:15		9	111			7	100				
01:30		5	159			4	110				
01:45		7	123	31	525	6	119	23	451	54	976
02:00		3	127			3	104				
02:15		7	136			4	142				
02:30		6	118			4	133				
02:45		9	136	25	517	10	159	21	538	46	1055
03:00		8	126			4	127				
03:15		11	113			13	140				
03:30		10	149			9	180				
03:45		10	128	39	516	12	141	38	588	77	1104
04:00		12	124			9	131				
04:15		15	145			13	140				
04:30		29	128			20	124				
04:45		23	158	79	555	33	163	75	558	154	1113
05:00		37	139			32	147				
05:15		65	160			38	177				
05:30		66	131			72	129				
05:45		68	162	236	592	71	82	213	535	449	1127
06:00		69	131			45	100				
06:15		71	102			54	108				
06:30		84	115			96	81				
06:45		120	121	344	469	87	82	282	371	626	840
07:00		106	84			95	73				
07:15		126	95			144	77				
07:30		136	80			158	70				
07:45		153	71	521	330	143	67	540	287	1061	617
08:00		85	76			133	62				
08:15		120	68			99	56				
08:30		100	64			97	49				
08:45		111	85	416	293	103	35	432	202	848	495
09:00		89	72			104	45				
09:15		92	62			101	44				
09:30		74	60			131	42				
09:45		80	38	335	232	99	30	435	161	770	393
10:00		92	31			120	35				
10:15		70	37			95	32				
10:30		110	36			114	19				
10:45		94	35	366	139	94	14	423	100	789	239
11:00		95	20			116	15				
11:15		117	15			113	22				
11:30		111	17			100	13				
11:45		117	12	440	64	109	15	438	65	878	129
Total		2875	4695	2875	4695	2959	4352	2959	4352	5834	9047
Combined Total		7570		7570		7311		7311		14881	
AM Peak	-	07:00	-	-	-	07:15	-	-	-	-	-
Vol.	-	521	-	-	-	578	-	-	-	-	-
P.H.F.	-	0.851	-	-	-	0.915	-	-	-	-	-
PM Peak	-	-	05:00	-	-	-	04:45	-	-	-	-
Vol.	-	-	592	-	-	-	616	-	-	-	-
P.H.F.	-	-	0.914	-	-	-	0.870	-	-	-	-
Percentage		38.0%	62.0%			40.5%	59.5%				
ADT/AADT		ADT 14,881	AADT 14,881								

Counts Unlimited, Inc.

City of Imperial
 State Route 86
 S/ Aten Road
 24 Hour Directional Volume Count

PO Box 1178
 Corona, CA 92878
 Phone: (951) 268-6268
 email: counts@countsunlimited.com

IPL009
 Site Code: 999-21570

Start Time	13-Oct-21 Wed	Northbound		Hour Totals		Southbound		Hour Totals		Combined Totals	
		Morning	Afternoon	Morning	Afternoon	Morning	Afternoon	Morning	Afternoon	Morning	Afternoon
12:00		14	190			12	204				
12:15		13	201			10	202				
12:30		8	195			9	222				
12:45		12	203	47	789	12	276	43	904	90	1693
01:00		7	176			6	268				
01:15		5	199			5	230				
01:30		6	216			3	188				
01:45		4	193	22	784	13	162	27	848	49	1632
02:00		7	204			7	190				
02:15		7	177			3	201				
02:30		2	172			10	205				
02:45		7	180	23	733	6	224	26	820	49	1553
03:00		3	176			4	190				
03:15		9	179			12	177				
03:30		5	199			9	217				
03:45		9	167	26	721	13	219	38	803	64	1524
04:00		11	205			9	204				
04:15		17	202			8	177				
04:30		17	169			13	198				
04:45		28	191	73	767	22	176	52	755	125	1522
05:00		37	209			22	171				
05:15		52	215			41	212				
05:30		41	252			29	203				
05:45		64	189	194	865	67	155	159	741	353	1606
06:00		40	182			53	150				
06:15		50	170			51	180				
06:30		84	180			70	187				
06:45		87	157	261	689	115	146	289	663	550	1352
07:00		75	176			101	138				
07:15		90	140			124	136				
07:30		120	145			201	119				
07:45		116	146	401	607	220	114	646	507	1047	1114
08:00		116	119			222	101				
08:15		106	121			197	89				
08:30		132	120			169	81				
08:45		121	116	475	476	163	68	751	339	1226	815
09:00		115	97			138	71				
09:15		114	63			159	57				
09:30		136	86			161	52				
09:45		128	62	493	308	206	58	664	238	1157	546
10:00		121	64			179	47				
10:15		115	46			187	48				
10:30		156	50			187	33				
10:45		154	37	546	197	202	27	755	155	1301	352
11:00		167	28			186	22				
11:15		153	24			197	17				
11:30		177	24			186	15				
11:45		203	11	700	87	201	13	770	67	1470	154
Total		3261	7023	3261	7023	4220	6840	4220	6840	7481	13863
Combined Total		10284		10284		11060		11060		21344	
AM Peak	-	11:00	-	-	-	07:30	-	-	-	-	-
Vol.	-	700	-	-	-	840	-	-	-	-	-
P.H.F.	-	0.862	-	-	-	0.946	-	-	-	-	-
PM Peak	-	-	04:45	-	-	-	00:30	-	-	-	-
Vol.	-	-	867	-	-	-	996	-	-	-	-
P.H.F.	-	-	0.860	-	-	-	0.902	-	-	-	-
Percentage		31.7%	68.3%			38.2%	61.8%				
ADT/AADT		ADT 21,344		AADT 21,344							

Appendix C

Intersection LOS Worksheets

Heritage at Dalia Ranch
1: SR-86 & Keystone Rd

Existing Conditions
Timing Plan: AM PEAK

Movement	EBL	EBT	EBR	WBL	WBT	WBR	NBL	NBT	NBR	SBL	SBT	SBR
Lane Configurations												
Traffic Volume (veh/h)	32	32	11	18	23	41	18	427	48	44	498	36
Future Volume (veh/h)	32	32	11	18	23	41	18	427	48	44	498	36
Initial Q (Qb), veh	0	0	0	0	0	0	0	0	0	0	0	0
Ped-Bike Adj(A_pbT)	1.00		1.00	1.00		1.00	1.00		1.00	1.00		1.00
Parking Bus, Adj	1.00	1.00	1.00	1.00	1.00	1.00	1.00	1.00	1.00	1.00	1.00	1.00
Work Zone On Approach		No			No			No			No	
Adj Sat Flow, veh/h/ln	1870	1870	1870	1870	1870	1870	1870	1870	1870	1870	1870	1870
Adj Flow Rate, veh/h	36	36	12	20	26	46	20	474	53	49	553	40
Peak Hour Factor	0.90	0.90	0.90	0.90	0.90	0.90	0.90	0.90	0.90	0.90	0.90	0.90
Percent Heavy Veh, %	2	2	2	2	2	2	2	2	2	2	2	2
Cap, veh/h	262	109	31	192	73	109	46	989	441	101	1098	490
Arrive On Green	0.13	0.13	0.13	0.13	0.13	0.13	0.03	0.28	0.28	0.06	0.31	0.31
Sat Flow, veh/h	598	822	237	272	551	822	1781	3554	1585	1781	3554	1585
Grp Volume(v), veh/h	84	0	0	92	0	0	20	474	53	49	553	40
Grp Sat Flow(s),veh/h/ln	1657	0	0	1645	0	0	1781	1777	1585	1781	1777	1585
Q Serve(g_s), s	0.0	0.0	0.0	0.2	0.0	0.0	0.3	3.1	0.7	0.8	3.6	0.5
Cycle Q Clear(g_c), s	1.2	0.0	0.0	1.4	0.0	0.0	0.3	3.1	0.7	0.8	3.6	0.5
Prop In Lane	0.43		0.14	0.22		0.50	1.00		1.00	1.00		1.00
Lane Grp Cap(c), veh/h	403	0	0	374	0	0	46	989	441	101	1098	490
V/C Ratio(X)	0.21	0.00	0.00	0.25	0.00	0.00	0.44	0.48	0.12	0.49	0.50	0.08
Avail Cap(c_a), veh/h	1191	0	0	1182	0	0	316	2271	1013	316	2271	1013
HCM Platoon Ratio	1.00	1.00	1.00	1.00	1.00	1.00	1.00	1.00	1.00	1.00	1.00	1.00
Upstream Filter(l)	1.00	0.00	0.00	1.00	0.00	0.00	1.00	1.00	1.00	1.00	1.00	1.00
Uniform Delay (d), s/veh	11.1	0.0	0.0	11.2	0.0	0.0	13.5	8.5	7.6	12.9	8.0	6.9
Incr Delay (d2), s/veh	0.3	0.0	0.0	0.3	0.0	0.0	6.4	0.4	0.1	3.6	0.4	0.1
Initial Q Delay(d3),s/veh	0.0	0.0	0.0	0.0	0.0	0.0	0.0	0.0	0.0	0.0	0.0	0.0
%ile BackOfQ(50%),veh/ln	0.4	0.0	0.0	0.4	0.0	0.0	0.2	0.8	0.2	0.3	0.9	0.1
Unsig. Movement Delay, s/veh												
LnGrp Delay(d),s/veh	11.4	0.0	0.0	11.5	0.0	0.0	19.9	8.8	7.7	16.5	8.3	7.0
LnGrp LOS	B	A	A	B	A	A	B	A	A	B	A	A
Approach Vol, veh/h		84			92			547			642	
Approach Delay, s/veh		11.4			11.5			9.1			8.9	
Approach LOS		B			B			A			A	
Timer - Assigned Phs	1	2		4	5	6		8				
Phs Duration (G+Y+Rc), s	6.6	12.8		8.7	5.7	13.7		8.7				
Change Period (Y+Rc), s	5.0	5.0		5.0	5.0	5.0		5.0				
Max Green Setting (Gmax), s	5.0	18.0		18.0	5.0	18.0		18.0				
Max Q Clear Time (g_c+I1), s	2.8	5.1		3.2	2.3	5.6		3.4				
Green Ext Time (p_c), s	0.0	2.7		0.3	0.0	3.1		0.3				
Intersection Summary												
HCM 6th Ctrl Delay				9.3								
HCM 6th LOS				A								

Intersection												
Int Delay, s/veh	0.6											
Movement	EBL	EBT	EBR	WBL	WBT	WBR	NBL	NBT	NBR	SBL	SBT	SBR
Lane Configurations		↕			↕		↕	↕		↕	↕	
Traffic Vol, veh/h	19	3	2	1	2	5	0	492	1	1	503	7
Future Vol, veh/h	19	3	2	1	2	5	0	492	1	1	503	7
Conflicting Peds, #/hr	0	0	0	0	0	0	0	0	0	0	0	0
Sign Control	Stop	Stop	Stop	Stop	Stop	Stop	Free	Free	Free	Free	Free	Free
RT Channelized	-	-	None	-	-	None	-	-	None	-	-	None
Storage Length	-	-	-	-	-	-	50	-	-	50	-	-
Veh in Median Storage, #	-	0	-	-	0	-	-	0	-	-	0	-
Grade, %	-	0	-	-	0	-	-	0	-	-	0	-
Peak Hour Factor	94	94	94	94	94	94	94	94	94	94	94	94
Heavy Vehicles, %	2	2	2	2	2	2	2	2	2	2	2	2
Mvmt Flow	20	3	2	1	2	5	0	523	1	1	535	7

Major/Minor	Minor2		Minor1		Major1			Major2				
Conflicting Flow All	804	1065	271	795	1068	262	542	0	0	524	0	0
Stage 1	541	541	-	524	524	-	-	-	-	-	-	-
Stage 2	263	524	-	271	544	-	-	-	-	-	-	-
Critical Hdwy	7.54	6.54	6.94	7.54	6.54	6.94	4.14	-	-	4.14	-	-
Critical Hdwy Stg 1	6.54	5.54	-	6.54	5.54	-	-	-	-	-	-	-
Critical Hdwy Stg 2	6.54	5.54	-	6.54	5.54	-	-	-	-	-	-	-
Follow-up Hdwy	3.52	4.02	3.32	3.52	4.02	3.32	2.22	-	-	2.22	-	-
Pot Cap-1 Maneuver	274	221	727	278	220	737	1023	-	-	1039	-	-
Stage 1	493	519	-	504	528	-	-	-	-	-	-	-
Stage 2	719	528	-	712	517	-	-	-	-	-	-	-
Platoon blocked, %								-	-	-	-	-
Mov Cap-1 Maneuver	270	221	727	274	220	737	1023	-	-	1039	-	-
Mov Cap-2 Maneuver	270	221	-	274	220	-	-	-	-	-	-	-
Stage 1	493	518	-	504	528	-	-	-	-	-	-	-
Stage 2	711	528	-	705	516	-	-	-	-	-	-	-

Approach	EB		WB		NB		SB	
HCM Control Delay, s	19.3		14		0		0	
HCM LOS	C		B					

Minor Lane/Major Mvmt	NBL	NBT	NBR	EBLn1	WBLn1	SBL	SBT	SBR
Capacity (veh/h)	1023	-	-	277	410	1039	-	-
HCM Lane V/C Ratio	-	-	-	0.092	0.021	0.001	-	-
HCM Control Delay (s)	0	-	-	19.3	14	8.5	-	-
HCM Lane LOS	A	-	-	C	B	A	-	-
HCM 95th %tile Q(veh)	0	-	-	0.3	0.1	0	-	-

Intersection						
Int Delay, s/veh	1.5					
Movement	WBL	WBR	NBT	NBR	SBL	SBT
Lane Configurations	Y		↑↑		↑	↑↑
Traffic Vol, veh/h	57	22	471	40	19	486
Future Vol, veh/h	57	22	471	40	19	486
Conflicting Peds, #/hr	0	0	0	0	0	0
Sign Control	Stop	Stop	Free	Free	Free	Free
RT Channelized	-	None	-	None	-	None
Storage Length	0	-	-	-	140	-
Veh in Median Storage, #	0	-	0	-	-	0
Grade, %	0	-	0	-	-	0
Peak Hour Factor	91	91	91	91	91	91
Heavy Vehicles, %	2	2	2	2	2	2
Mvmt Flow	63	24	518	44	21	534

Major/Minor	Minor1	Major1	Major2		
Conflicting Flow All	849	281	0	0	562
Stage 1	540	-	-	-	-
Stage 2	309	-	-	-	-
Critical Hdwy	6.84	6.94	-	-	4.14
Critical Hdwy Stg 1	5.84	-	-	-	-
Critical Hdwy Stg 2	5.84	-	-	-	-
Follow-up Hdwy	3.52	3.32	-	-	2.22
Pot Cap-1 Maneuver	300	716	-	-	1005
Stage 1	548	-	-	-	-
Stage 2	718	-	-	-	-
Platoon blocked, %			-	-	-
Mov Cap-1 Maneuver	294	716	-	-	1005
Mov Cap-2 Maneuver	294	-	-	-	-
Stage 1	548	-	-	-	-
Stage 2	703	-	-	-	-

Approach	WB	NB	SB
HCM Control Delay, s	18.5	0	0.3
HCM LOS	C		

Minor Lane/Major Mvmt	NBT	NBRWBLn1	SBL	SBT
Capacity (veh/h)	-	-	352	1005
HCM Lane V/C Ratio	-	-	0.247	0.021
HCM Control Delay (s)	-	-	18.5	8.7
HCM Lane LOS	-	-	C	A
HCM 95th %tile Q(veh)	-	-	1	0.1

Heritage at Dalia Ranch
4: Imperial Ave & Neckel Rd

Existing Conditions
Timing Plan: AM PEAK



Movement	EBL	EBT	EBR	WBL	WBT	WBR	NBL	NBT	NBR	SBL	SBT	SBR
Lane Configurations		↕			↕		↕	↕		↕	↕	
Traffic Volume (veh/h)	33	42	12	138	62	54	8	430	63	14	497	30
Future Volume (veh/h)	33	42	12	138	62	54	8	430	63	14	497	30
Initial Q (Qb), veh	0	0	0	0	0	0	0	0	0	0	0	0
Ped-Bike Adj(A_pbT)	1.00		1.00	1.00		1.00	1.00		1.00	1.00		1.00
Parking Bus, Adj	1.00	1.00	1.00	1.00	1.00	1.00	1.00	1.00	1.00	1.00	1.00	1.00
Work Zone On Approach		No			No			No			No	
Adj Sat Flow, veh/h/ln	1870	1870	1870	1870	1870	1870	1870	1870	1870	1870	1870	1870
Adj Flow Rate, veh/h	36	46	13	152	68	59	9	473	69	15	546	33
Peak Hour Factor	0.91	0.91	0.91	0.91	0.91	0.91	0.91	0.91	0.91	0.91	0.91	0.91
Percent Heavy Veh, %	2	2	2	2	2	2	2	2	2	2	2	2
Cap, veh/h	53	67	19	203	91	79	21	749	109	34	844	51
Arrive On Green	0.08	0.08	0.08	0.21	0.21	0.21	0.01	0.24	0.24	0.02	0.25	0.25
Sat Flow, veh/h	679	868	245	957	428	371	1781	3114	452	1781	3405	205
Grp Volume(v), veh/h	95	0	0	279	0	0	9	269	273	15	284	295
Grp Sat Flow(s),veh/h/ln	1792	0	0	1756	0	0	1781	1777	1789	1781	1777	1833
Q Serve(g_s), s	2.3	0.0	0.0	6.6	0.0	0.0	0.2	6.0	6.1	0.4	6.4	6.4
Cycle Q Clear(g_c), s	2.3	0.0	0.0	6.6	0.0	0.0	0.2	6.0	6.1	0.4	6.4	6.4
Prop In Lane	0.38		0.14	0.54		0.21	1.00		0.25	1.00		0.11
Lane Grp Cap(c), veh/h	139	0	0	372	0	0	21	427	430	34	440	454
V/C Ratio(X)	0.68	0.00	0.00	0.75	0.00	0.00	0.43	0.63	0.63	0.44	0.65	0.65
Avail Cap(c_a), veh/h	727	0	0	713	0	0	201	761	766	201	761	785
HCM Platoon Ratio	1.00	1.00	1.00	1.00	1.00	1.00	1.00	1.00	1.00	1.00	1.00	1.00
Upstream Filter(l)	1.00	0.00	0.00	1.00	0.00	0.00	1.00	1.00	1.00	1.00	1.00	1.00
Uniform Delay (d), s/veh	19.9	0.0	0.0	16.4	0.0	0.0	21.8	15.1	15.1	21.5	14.9	15.0
Incr Delay (d2), s/veh	5.7	0.0	0.0	3.1	0.0	0.0	13.1	1.5	1.6	8.8	1.6	1.6
Initial Q Delay(d3),s/veh	0.0	0.0	0.0	0.0	0.0	0.0	0.0	0.0	0.0	0.0	0.0	0.0
%ile BackOfQ(50%),veh/ln	1.1	0.0	0.0	2.6	0.0	0.0	0.2	2.2	2.3	0.2	2.4	2.4
Unsig. Movement Delay, s/veh												
LnGrp Delay(d),s/veh	25.7	0.0	0.0	19.4	0.0	0.0	34.9	16.6	16.6	30.3	16.5	16.5
LnGrp LOS	C	A	A	B	A	A	C	B	B	C	B	B
Approach Vol, veh/h		95			279			551			594	
Approach Delay, s/veh		25.7			19.4			16.9			16.9	
Approach LOS		C			B			B			B	
Timer - Assigned Phs	1	2		4	5	6		8				
Phs Duration (G+Y+Rc), s	5.8	15.7		8.4	5.5	16.0		14.4				
Change Period (Y+Rc), s	5.0	5.0		5.0	5.0	5.0		5.0				
Max Green Setting (Gmax), s	5.0	19.0		18.0	5.0	19.0		18.0				
Max Q Clear Time (g_c+I1), s	2.4	8.1		4.3	2.2	8.4		8.6				
Green Ext Time (p_c), s	0.0	2.5		0.3	0.0	2.6		1.1				
Intersection Summary												
HCM 6th Ctrl Delay				17.9								
HCM 6th LOS				B								

Heritage at Dalia Ranch
5: La Brucherie Rd & Neckel Rd

Existing Conditions
Timing Plan: AM PEAK

Intersection												
Int Delay, s/veh	7.6											
Movement	EBL	EBT	EBR	WBL	WBT	WBR	NBL	NBT	NBR	SBL	SBT	SBR
Lane Configurations		↕			↕			↕			↕	
Traffic Vol, veh/h	4	40	22	58	43	0	7	6	41	1	2	1
Future Vol, veh/h	4	40	22	58	43	0	7	6	41	1	2	1
Conflicting Peds, #/hr	0	0	0	0	0	0	0	0	0	0	0	0
Sign Control	Stop	Stop	Stop	Stop	Stop	Stop	Free	Free	Free	Free	Free	Free
RT Channelized	-	-	None	-	-	None	-	-	None	-	-	None
Storage Length	-	-	-	-	-	-	-	-	-	-	-	-
Veh in Median Storage, #	-	0	-	-	0	-	-	0	-	-	0	-
Grade, %	-	0	-	-	0	-	-	0	-	-	0	-
Peak Hour Factor	79	79	79	79	79	79	79	79	79	79	79	79
Heavy Vehicles, %	2	2	2	2	2	2	2	2	2	2	2	2
Mvmt Flow	5	51	28	73	54	0	9	8	52	1	3	1

Major/Minor	Minor2		Minor1		Major1			Major2				
Conflicting Flow All	85	84	4	97	58	34	4	0	0	60	0	0
Stage 1	6	6	-	52	52	-	-	-	-	-	-	-
Stage 2	79	78	-	45	6	-	-	-	-	-	-	-
Critical Hdwy	7.12	6.52	6.22	7.12	6.52	6.22	4.12	-	-	4.12	-	-
Critical Hdwy Stg 1	6.12	5.52	-	6.12	5.52	-	-	-	-	-	-	-
Critical Hdwy Stg 2	6.12	5.52	-	6.12	5.52	-	-	-	-	-	-	-
Follow-up Hdwy	3.518	4.018	3.318	3.518	4.018	3.318	2.218	-	-	2.218	-	-
Pot Cap-1 Maneuver	901	806	1080	885	833	1039	1618	-	-	1544	-	-
Stage 1	1016	891	-	961	852	-	-	-	-	-	-	-
Stage 2	930	830	-	969	891	-	-	-	-	-	-	-
Platoon blocked, %								-	-	-	-	-
Mov Cap-1 Maneuver	851	800	1080	816	827	1039	1618	-	-	1544	-	-
Mov Cap-2 Maneuver	851	800	-	816	827	-	-	-	-	-	-	-
Stage 1	1010	890	-	955	847	-	-	-	-	-	-	-
Stage 2	865	825	-	889	890	-	-	-	-	-	-	-

Approach	EB		WB		NB		SB	
HCM Control Delay, s	9.5		10.2		0.9		1.8	
HCM LOS	A		B					

Minor Lane/Major Mvmt	NBL	NBT	NBR	EBLn1	WBLn1	SBL	SBT	SBR
Capacity (veh/h)	1618	-	-	879	821	1544	-	-
HCM Lane V/C Ratio	0.005	-	-	0.095	0.156	0.001	-	-
HCM Control Delay (s)	7.2	0	-	9.5	10.2	7.3	0	-
HCM Lane LOS	A	A	-	A	B	A	A	-
HCM 95th %tile Q(veh)	0	-	-	0.3	0.6	0	-	-

Heritage at Dalia Ranch
6: Imperial Ave & Worthington Rd/Barioni Blvd

Existing Conditions
Timing Plan: AM PEAK

Movement	EBL	EBT	EBR	WBL	WBT	WBR	NBL	NBT	NBR	SBL	SBT	SBR
Lane Configurations												
Traffic Volume (veh/h)	68	132	206	53	128	75	90	452	49	38	613	54
Future Volume (veh/h)	68	132	206	53	128	75	90	452	49	38	613	54
Initial Q (Qb), veh	0	0	0	0	0	0	0	0	0	0	0	0
Ped-Bike Adj(A_pbT)	1.00		1.00	1.00		1.00	1.00		1.00	1.00		1.00
Parking Bus, Adj	1.00	1.00	1.00	1.00	1.00	1.00	1.00	1.00	1.00	1.00	1.00	1.00
Work Zone On Approach		No			No			No			No	
Adj Sat Flow, veh/h/ln	1870	1870	1870	1870	1870	1870	1870	1870	1870	1870	1870	1870
Adj Flow Rate, veh/h	76	148	231	60	144	84	101	508	55	43	689	61
Peak Hour Factor	0.89	0.89	0.89	0.89	0.89	0.89	0.89	0.89	0.89	0.89	0.89	0.89
Percent Heavy Veh, %	2	2	2	2	2	2	2	2	2	2	2	2
Cap, veh/h	119	232	303	82	198	241	129	941	102	75	860	76
Arrive On Green	0.19	0.19	0.19	0.15	0.15	0.15	0.07	0.29	0.29	0.04	0.26	0.26
Sat Flow, veh/h	624	1215	1585	542	1301	1585	1781	3235	349	1781	3302	292
Grp Volume(v), veh/h	224	0	231	204	0	84	101	278	285	43	370	380
Grp Sat Flow(s),veh/h/ln	1839	0	1585	1843	0	1585	1781	1777	1808	1781	1777	1818
Q Serve(g_s), s	6.9	0.0	8.5	6.5	0.0	2.9	3.4	8.1	8.2	1.5	12.0	12.1
Cycle Q Clear(g_c), s	6.9	0.0	8.5	6.5	0.0	2.9	3.4	8.1	8.2	1.5	12.0	12.1
Prop In Lane	0.34		1.00	0.29		1.00	1.00		0.19	1.00		0.16
Lane Grp Cap(c), veh/h	352	0	303	280	0	241	129	517	526	75	463	474
V/C Ratio(X)	0.64	0.00	0.76	0.73	0.00	0.35	0.78	0.54	0.54	0.57	0.80	0.80
Avail Cap(c_a), veh/h	536	0	462	537	0	462	144	546	556	144	546	559
HCM Platoon Ratio	1.00	1.00	1.00	1.00	1.00	1.00	1.00	1.00	1.00	1.00	1.00	1.00
Upstream Filter(l)	1.00	0.00	1.00	1.00	0.00	1.00	1.00	1.00	1.00	1.00	1.00	1.00
Uniform Delay (d), s/veh	23.0	0.0	23.7	25.0	0.0	23.5	28.2	18.4	18.4	29.0	21.3	21.4
Incr Delay (d2), s/veh	1.9	0.0	4.0	3.6	0.0	0.9	21.7	0.9	0.9	6.7	7.2	7.1
Initial Q Delay(d3),s/veh	0.0	0.0	0.0	0.0	0.0	0.0	0.0	0.0	0.0	0.0	0.0	0.0
%ile BackOfQ(50%),veh/ln	3.0	0.0	3.3	3.0	0.0	1.1	2.2	3.2	3.3	0.7	5.5	5.6
Unsig. Movement Delay, s/veh												
LnGrp Delay(d),s/veh	24.9	0.0	27.6	28.6	0.0	24.3	49.9	19.4	19.4	35.7	28.5	28.4
LnGrp LOS	C	A	C	C	A	C	D	B	B	D	C	C
Approach Vol, veh/h		455			288			664			793	
Approach Delay, s/veh		26.3			27.3			24.0			28.9	
Approach LOS		C			C			C			C	
Timer - Assigned Phs	1	2		4	5	6		8				
Phs Duration (G+Y+Rc), s	7.6	23.0		16.8	9.5	21.1		14.4				
Change Period (Y+Rc), s	5.0	5.0		5.0	5.0	5.0		5.0				
Max Green Setting (Gmax), s	5.0	19.0		18.0	5.0	19.0		18.0				
Max Q Clear Time (g_c+I1), s	3.5	10.2		10.5	5.4	14.1		8.5				
Green Ext Time (p_c), s	0.0	2.3		1.3	0.0	2.0		1.0				
Intersection Summary												
HCM 6th Ctrl Delay			26.7									
HCM 6th LOS			C									

Intersection												
Intersection Delay, s/veh	24.2											
Intersection LOS	C											

Movement	EBL	EBT	EBR	WBL	WBT	WBR	NBL	NBT	NBR	SBL	SBT	SBR
Lane Configurations		↔	↔		↔	↔		↔			↔	
Traffic Vol, veh/h	59	379	116	11	293	75	0	0	1	103	30	62
Future Vol, veh/h	59	379	116	11	293	75	0	0	1	103	30	62
Peak Hour Factor	0.83	0.83	0.83	0.83	0.83	0.83	0.83	0.83	0.83	0.83	0.83	0.83
Heavy Vehicles, %	2	2	2	2	2	2	2	2	2	2	2	2
Mvmt Flow	71	457	140	13	353	90	0	0	1	124	36	75
Number of Lanes	0	1	1	0	1	1	0	1	0	0	1	0

Approach	EB	WB	NB	SB
Opposing Approach	WB	EB	SB	NB
Opposing Lanes	2	2	1	1
Conflicting Approach Left	SB	NB	EB	WB
Conflicting Lanes Left	1	1	2	2
Conflicting Approach Right	NB	SB	WB	EB
Conflicting Lanes Right	1	1	2	2
HCM Control Delay	32.4	17.3	9.9	14.2
HCM LOS	D	C	A	B

Lane	NBLn1	EBLn1	EBLn2	WBLn1	WBLn2	SBLn1
Vol Left, %	0%	13%	0%	4%	0%	53%
Vol Thru, %	0%	87%	0%	96%	0%	15%
Vol Right, %	100%	0%	100%	0%	100%	32%
Sign Control	Stop	Stop	Stop	Stop	Stop	Stop
Traffic Vol by Lane	1	438	116	304	75	195
LT Vol	0	59	0	11	0	103
Through Vol	0	379	0	293	0	30
RT Vol	1	0	116	0	75	62
Lane Flow Rate	1	528	140	366	90	235
Geometry Grp	2	7	7	7	7	2
Degree of Util (X)	0.002	0.885	0.204	0.635	0.138	0.421
Departure Headway (Hd)	6.89	6.037	5.259	6.241	5.51	6.454
Convergence, Y/N	Yes	Yes	Yes	Yes	Yes	Yes
Cap	523	602	681	579	648	557
Service Time	4.89	3.789	3.009	3.999	3.268	4.518
HCM Lane V/C Ratio	0.002	0.877	0.206	0.632	0.139	0.422
HCM Control Delay	9.9	38.5	9.4	19.3	9.2	14.2
HCM Lane LOS	A	E	A	C	A	B
HCM 95th-tile Q	0	10.4	0.8	4.5	0.5	2.1

Heritage at Dalia Ranch
8: Imperial Ave & Aten Rd



















Existing Conditions
Timing Plan: AM PEAK



Movement	EBL	EBT	EBR	WBL	WBT	WBR	NBL	NBT	NBR	SBL	SBT	SBR
Lane Configurations	↖	↑↑		↖	↑↑		↖	↑↑	↖	↖	↑↑	↖
Traffic Volume (veh/h)	181	328	61	127	291	137	59	334	65	138	652	365
Future Volume (veh/h)	181	328	61	127	291	137	59	334	65	138	652	365
Initial Q (Qb), veh	0	0	0	0	0	0	0	0	0	0	0	0
Ped-Bike Adj(A_pbT)	1.00		1.00	1.00		1.00	1.00		1.00	1.00		1.00
Parking Bus, Adj	1.00	1.00	1.00	1.00	1.00	1.00	1.00	1.00	1.00	1.00	1.00	1.00
Work Zone On Approach		No		No		No		No		No		No
Adj Sat Flow, veh/h/ln	1870	1870	1870	1870	1870	1870	1870	1870	1870	1870	1870	1870
Adj Flow Rate, veh/h	210	381	71	148	338	159	69	388	76	160	758	424
Peak Hour Factor	0.86	0.86	0.86	0.86	0.86	0.86	0.86	0.86	0.86	0.86	0.86	0.86
Percent Heavy Veh, %	2	2	2	2	2	2	2	2	2	2	2	2
Cap, veh/h	253	690	127	187	456	210	96	901	402	199	1106	493
Arrive On Green	0.14	0.23	0.23	0.10	0.19	0.19	0.05	0.25	0.25	0.11	0.31	0.31
Sat Flow, veh/h	1781	2995	553	1781	2361	1090	1781	3554	1585	1781	3554	1585
Grp Volume(v), veh/h	210	225	227	148	253	244	69	388	76	160	758	424
Grp Sat Flow(s),veh/h/ln	1781	1777	1771	1781	1777	1674	1781	1777	1585	1781	1777	1585
Q Serve(g_s), s	7.7	7.4	7.6	5.4	8.9	9.2	2.5	6.1	2.5	5.9	12.5	16.8
Cycle Q Clear(g_c), s	7.7	7.4	7.6	5.4	8.9	9.2	2.5	6.1	2.5	5.9	12.5	16.8
Prop In Lane	1.00		0.31	1.00		0.65	1.00		1.00	1.00		1.00
Lane Grp Cap(c), veh/h	253	409	408	187	343	323	96	901	402	199	1106	493
V/C Ratio(X)	0.83	0.55	0.56	0.79	0.74	0.76	0.72	0.43	0.19	0.80	0.69	0.86
Avail Cap(c_a), veh/h	267	506	504	240	479	452	133	1012	451	214	1171	522
HCM Platoon Ratio	1.00	1.00	1.00	1.00	1.00	1.00	1.00	1.00	1.00	1.00	1.00	1.00
Upstream Filter(l)	1.00	1.00	1.00	1.00	1.00	1.00	1.00	1.00	1.00	1.00	1.00	1.00
Uniform Delay (d), s/veh	27.8	22.6	22.7	29.2	25.3	25.4	31.1	20.9	19.5	28.9	20.1	21.6
Incr Delay (d2), s/veh	18.6	1.1	1.2	12.9	3.7	4.6	10.6	0.3	0.2	18.6	1.6	13.1
Initial Q Delay(d3),s/veh	0.0	0.0	0.0	0.0	0.0	0.0	0.0	0.0	0.0	0.0	0.0	0.0
%ile BackOfQ(50%),veh/ln	4.4	3.1	3.1	2.9	3.9	3.9	1.3	2.4	0.9	3.4	5.0	7.5
Unsig. Movement Delay, s/veh												
LnGrp Delay(d),s/veh	46.5	23.8	23.9	42.1	29.0	30.1	41.7	21.2	19.8	47.6	21.7	34.7
LnGrp LOS	D	C	C	D	C	C	D	C	B	D	C	C
Approach Vol, veh/h		662			645			533			1342	
Approach Delay, s/veh		31.0			32.4			23.6			28.9	
Approach LOS		C			C			C			C	
Timer - Assigned Phs	1	2	3	4	5	6	7	8				
Phs Duration (G+Y+Rc), s	2.5	21.9	12.0	20.4	8.6	25.8	14.5	17.9				
Change Period (Y+Rc), s	5.0	5.0	5.0	5.0	5.0	5.0	5.0	5.0				
Max Green Setting (Gmax), s	19.0	19.0	9.0	19.0	5.0	22.0	10.0	18.0				
Max Q Clear Time (g_c+1), s	8.1	8.1	7.4	9.6	4.5	18.8	9.7	11.2				
Green Ext Time (p_c), s	0.0	2.1	0.1	1.8	0.0	2.0	0.0	1.7				
Intersection Summary												
HCM 6th Ctrl Delay											29.2	
HCM 6th LOS											C	

Heritage at Dalia Ranch
1: SR-86 & Keystone Rd

Existing Conditions
Timing Plan: PM PEAK

												
Movement	EBL	EBT	EBR	WBL	WBT	WBR	NBL	NBT	NBR	SBL	SBT	SBR
Lane Configurations												
Traffic Volume (veh/h)	40	12	19	32	26	36	10	509	25	51	527	33
Future Volume (veh/h)	40	12	19	32	26	36	10	509	25	51	527	33
Initial Q (Qb), veh	0	0	0	0	0	0	0	0	0	0	0	0
Ped-Bike Adj(A_pbT)	1.00		1.00	1.00		1.00	1.00		1.00	1.00		1.00
Parking Bus, Adj	1.00	1.00	1.00	1.00	1.00	1.00	1.00	1.00	1.00	1.00	1.00	1.00
Work Zone On Approach		No			No			No			No	
Adj Sat Flow, veh/h/ln	1870	1870	1870	1870	1870	1870	1870	1870	1870	1870	1870	1870
Adj Flow Rate, veh/h	45	13	21	36	29	40	11	572	28	57	592	37
Peak Hour Factor	0.89	0.89	0.89	0.89	0.89	0.89	0.89	0.89	0.89	0.89	0.89	0.89
Percent Heavy Veh, %	2	2	2	2	2	2	2	2	2	2	2	2
Cap, veh/h	290	50	56	220	71	81	26	1111	495	112	1282	572
Arrive On Green	0.13	0.13	0.13	0.13	0.13	0.13	0.01	0.31	0.31	0.06	0.36	0.36
Sat Flow, veh/h	798	386	429	466	547	624	1781	3554	1585	1781	3554	1585
Grp Volume(v), veh/h	79	0	0	105	0	0	11	572	28	57	592	37
Grp Sat Flow(s),veh/h/ln	1613	0	0	1638	0	0	1781	1777	1585	1781	1777	1585
Q Serve(g_s), s	0.0	0.0	0.0	0.5	0.0	0.0	0.2	4.0	0.4	0.9	3.9	0.5
Cycle Q Clear(g_c), s	1.2	0.0	0.0	1.7	0.0	0.0	0.2	4.0	0.4	0.9	3.9	0.5
Prop In Lane	0.57		0.27	0.34		0.38	1.00		1.00	1.00		1.00
Lane Grp Cap(c), veh/h	396	0	0	372	0	0	26	1111	495	112	1282	572
V/C Ratio(X)	0.20	0.00	0.00	0.28	0.00	0.00	0.42	0.51	0.06	0.51	0.46	0.06
Avail Cap(c_a), veh/h	1074	0	0	1100	0	0	294	2461	1098	352	2578	1150
HCM Platoon Ratio	1.00	1.00	1.00	1.00	1.00	1.00	1.00	1.00	1.00	1.00	1.00	1.00
Upstream Filter(l)	1.00	0.00	0.00	1.00	0.00	0.00	1.00	1.00	1.00	1.00	1.00	1.00
Uniform Delay (d), s/veh	12.0	0.0	0.0	12.2	0.0	0.0	14.8	8.5	7.3	13.8	7.4	6.3
Incr Delay (d2), s/veh	0.2	0.0	0.0	0.4	0.0	0.0	10.6	0.4	0.0	3.5	0.3	0.0
Initial Q Delay(d3),s/veh	0.0	0.0	0.0	0.0	0.0	0.0	0.0	0.0	0.0	0.0	0.0	0.0
%ile BackOfQ(50%),veh/ln	0.4	0.0	0.0	0.5	0.0	0.0	0.1	1.1	0.1	0.4	0.9	0.1
Unsig. Movement Delay, s/veh												
LnGrp Delay(d),s/veh	12.3	0.0	0.0	12.6	0.0	0.0	25.4	8.9	7.3	17.3	7.7	6.4
LnGrp LOS	B	A	A	B	A	A	C	A	A	B	A	A
Approach Vol, veh/h		79			105			611			686	
Approach Delay, s/veh		12.3			12.6			9.1			8.4	
Approach LOS		B			B			A			A	
Timer - Assigned Phs	1	2		4	5	6		8				
Phs Duration (G+Y+Rc), s	6.9	14.5		8.9	5.4	15.9		8.9				
Change Period (Y+Rc), s	5.0	5.0		5.0	5.0	5.0		5.0				
Max Green Setting (Gmax), s	6.0	21.0		18.0	5.0	22.0		18.0				
Max Q Clear Time (g_c+I1), s	2.9	6.0		3.2	2.2	5.9		3.7				
Green Ext Time (p_c), s	0.0	3.5		0.3	0.0	3.8		0.4				
Intersection Summary												
HCM 6th Ctrl Delay				9.2								
HCM 6th LOS				A								

Intersection												
Int Delay, s/veh	0.4											
Movement	EBL	EBT	EBR	WBL	WBT	WBR	NBL	NBT	NBR	SBL	SBT	SBR
Lane Configurations		↕			↕		↕	↕		↕	↕	
Traffic Vol, veh/h	6	4	0	7	0	5	1	546	7	6	562	17
Future Vol, veh/h	6	4	0	7	0	5	1	546	7	6	562	17
Conflicting Peds, #/hr	0	0	0	0	0	0	0	0	0	0	0	0
Sign Control	Stop	Stop	Stop	Stop	Stop	Stop	Free	Free	Free	Free	Free	Free
RT Channelized	-	-	None	-	-	None	-	-	None	-	-	None
Storage Length	-	-	-	-	-	-	50	-	-	50	-	-
Veh in Median Storage, #	-	0	-	-	0	-	-	0	-	-	0	-
Grade, %	-	0	-	-	0	-	-	0	-	-	0	-
Peak Hour Factor	92	92	92	92	92	92	92	92	92	92	92	92
Heavy Vehicles, %	2	2	2	2	2	2	2	2	2	2	2	2
Mvmt Flow	7	4	0	8	0	5	1	593	8	7	611	18

Major/Minor	Minor2		Minor1		Major1		Major2					
Conflicting Flow All	933	1237	315	921	1242	301	629	0	0	601	0	0
Stage 1	634	634	-	599	599	-	-	-	-	-	-	-
Stage 2	299	603	-	322	643	-	-	-	-	-	-	-
Critical Hdwy	7.54	6.54	6.94	7.54	6.54	6.94	4.14	-	-	4.14	-	-
Critical Hdwy Stg 1	6.54	5.54	-	6.54	5.54	-	-	-	-	-	-	-
Critical Hdwy Stg 2	6.54	5.54	-	6.54	5.54	-	-	-	-	-	-	-
Follow-up Hdwy	3.52	4.02	3.32	3.52	4.02	3.32	2.22	-	-	2.22	-	-
Pot Cap-1 Maneuver	221	175	681	225	173	695	949	-	-	972	-	-
Stage 1	434	471	-	455	489	-	-	-	-	-	-	-
Stage 2	685	487	-	664	467	-	-	-	-	-	-	-
Platoon blocked, %								-	-	-	-	-
Mov Cap-1 Maneuver	218	174	681	219	172	695	949	-	-	972	-	-
Mov Cap-2 Maneuver	218	174	-	219	172	-	-	-	-	-	-	-
Stage 1	434	468	-	455	489	-	-	-	-	-	-	-
Stage 2	679	487	-	653	464	-	-	-	-	-	-	-

Approach	EB		WB		NB		SB	
HCM Control Delay, s	24.2		17.3		0		0.1	
HCM LOS	C		C					

Minor Lane/Major Mvmt	NBL	NBT	NBR	EBLn1	WBLn1	SBL	SBT	SBR
Capacity (veh/h)	949	-	-	198	306	972	-	-
HCM Lane V/C Ratio	0.001	-	-	0.055	0.043	0.007	-	-
HCM Control Delay (s)	8.8	-	-	24.2	17.3	8.7	-	-
HCM Lane LOS	A	-	-	C	C	A	-	-
HCM 95th %tile Q(veh)	0	-	-	0.2	0.1	0	-	-

Intersection						
Int Delay, s/veh	0.7					
Movement	WBL	WBR	NBT	NBR	SBL	SBT
Lane Configurations	W		T		T	T
Traffic Vol, veh/h	19	10	547	29	29	527
Future Vol, veh/h	19	10	547	29	29	527
Conflicting Peds, #/hr	0	0	0	0	0	0
Sign Control	Stop	Stop	Free	Free	Free	Free
RT Channelized	-	None	-	None	-	None
Storage Length	0	-	-	-	140	-
Veh in Median Storage, #	0	-	0	-	-	0
Grade, %	0	-	0	-	-	0
Peak Hour Factor	91	91	91	91	91	91
Heavy Vehicles, %	2	2	2	2	2	2
Mvmt Flow	21	11	601	32	32	579

Major/Minor	Minor1	Major1	Major2		
Conflicting Flow All	971	317	0	0	633
Stage 1	617	-	-	-	-
Stage 2	354	-	-	-	-
Critical Hdwy	6.84	6.94	-	-	4.14
Critical Hdwy Stg 1	5.84	-	-	-	-
Critical Hdwy Stg 2	5.84	-	-	-	-
Follow-up Hdwy	3.52	3.32	-	-	2.22
Pot Cap-1 Maneuver	250	679	-	-	946
Stage 1	501	-	-	-	-
Stage 2	681	-	-	-	-
Platoon blocked, %			-	-	-
Mov Cap-1 Maneuver	242	679	-	-	946
Mov Cap-2 Maneuver	242	-	-	-	-
Stage 1	501	-	-	-	-
Stage 2	658	-	-	-	-

Approach	WB	NB	SB
HCM Control Delay, s	17.9	0	0.5
HCM LOS	C		

Minor Lane/Major Mvmt	NBT	NBRWBLn1	SBL	SBT
Capacity (veh/h)	-	-	311	946
HCM Lane V/C Ratio	-	-	0.102	0.034
HCM Control Delay (s)	-	-	17.9	8.9
HCM Lane LOS	-	-	C	A
HCM 95th %tile Q(veh)	-	-	0.3	0.1

Heritage at Dalia Ranch
4: Imperial Ave & Neckel Rd

Existing Conditions
Timing Plan: PM PEAK

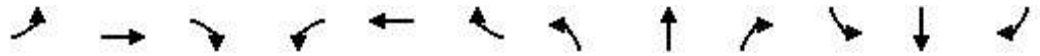

Movement	EBL	EBT	EBR	WBL	WBT	WBR	NBL	NBT	NBR	SBL	SBT	SBR
Lane Configurations		↕			↕		↕	↕↔		↕	↕↔	
Traffic Volume (veh/h)	12	25	4	80	19	45	11	540	81	28	482	27
Future Volume (veh/h)	12	25	4	80	19	45	11	540	81	28	482	27
Initial Q (Qb), veh	0	0	0	0	0	0	0	0	0	0	0	0
Ped-Bike Adj(A_pbT)	1.00		1.00	1.00		1.00	1.00		1.00	1.00		1.00
Parking Bus, Adj	1.00	1.00	1.00	1.00	1.00	1.00	1.00	1.00	1.00	1.00	1.00	1.00
Work Zone On Approach		No			No			No			No	
Adj Sat Flow, veh/h/ln	1870	1870	1870	1870	1870	1870	1870	1870	1870	1870	1870	1870
Adj Flow Rate, veh/h	13	27	4	87	21	49	12	587	88	30	524	29
Peak Hour Factor	0.92	0.92	0.92	0.92	0.92	0.92	0.92	0.92	0.92	0.92	0.92	0.92
Percent Heavy Veh, %	2	2	2	2	2	2	2	2	2	2	2	2
Cap, veh/h	26	54	8	121	29	68	28	905	135	63	1068	59
Arrive On Green	0.05	0.05	0.05	0.13	0.13	0.13	0.02	0.29	0.29	0.04	0.31	0.31
Sat Flow, veh/h	536	1113	165	956	231	539	1781	3100	464	1781	3424	189
Grp Volume(v), veh/h	44	0	0	157	0	0	12	336	339	30	271	282
Grp Sat Flow(s),veh/h/ln	1814	0	0	1726	0	0	1781	1777	1787	1781	1777	1836
Q Serve(g_s), s	1.0	0.0	0.0	3.5	0.0	0.0	0.3	6.6	6.7	0.7	5.0	5.0
Cycle Q Clear(g_c), s	1.0	0.0	0.0	3.5	0.0	0.0	0.3	6.6	6.7	0.7	5.0	5.0
Prop In Lane	0.30		0.09	0.55		0.31	1.00		0.26	1.00		0.10
Lane Grp Cap(c), veh/h	88	0	0	218	0	0	28	519	522	63	554	573
V/C Ratio(X)	0.50	0.00	0.00	0.72	0.00	0.00	0.43	0.65	0.65	0.48	0.49	0.49
Avail Cap(c_a), veh/h	813	0	0	773	0	0	222	840	845	222	840	869
HCM Platoon Ratio	1.00	1.00	1.00	1.00	1.00	1.00	1.00	1.00	1.00	1.00	1.00	1.00
Upstream Filter(l)	1.00	0.00	0.00	1.00	0.00	0.00	1.00	1.00	1.00	1.00	1.00	1.00
Uniform Delay (d), s/veh	18.6	0.0	0.0	16.9	0.0	0.0	19.6	12.4	12.4	19.0	11.2	11.2
Incr Delay (d2), s/veh	4.4	0.0	0.0	4.4	0.0	0.0	10.2	1.4	1.4	5.5	0.7	0.7
Initial Q Delay(d3),s/veh	0.0	0.0	0.0	0.0	0.0	0.0	0.0	0.0	0.0	0.0	0.0	0.0
%ile BackOfQ(50%),veh/ln	0.5	0.0	0.0	1.5	0.0	0.0	0.2	2.3	2.3	0.3	1.6	1.7
Unsig. Movement Delay, s/veh												
LnGrp Delay(d),s/veh	23.0	0.0	0.0	21.3	0.0	0.0	29.8	13.8	13.8	24.5	11.9	11.9
LnGrp LOS	C	A	A	C	A	A	C	B	B	C	B	B
Approach Vol, veh/h		44			157			687			583	
Approach Delay, s/veh		23.0			21.3			14.1			12.5	
Approach LOS		C			C			B			B	
Timer - Assigned Phs	1	2		4	5	6		8				
Phs Duration (G+Y+Rc), s	6.4	16.7		6.9	5.6	17.5		10.1				
Change Period (Y+Rc), s	5.0	5.0		5.0	5.0	5.0		5.0				
Max Green Setting (Gmax), s	5.0	19.0		18.0	5.0	19.0		18.0				
Max Q Clear Time (g_c+I1), s	2.7	8.7		3.0	2.3	7.0		5.5				
Green Ext Time (p_c), s	0.0	3.1		0.1	0.0	2.6		0.6				
Intersection Summary												
HCM 6th Ctrl Delay				14.5								
HCM 6th LOS				B								

Intersection												
Int Delay, s/veh	7.6											
Movement	EBL	EBT	EBR	WBL	WBT	WBR	NBL	NBT	NBR	SBL	SBT	SBR
Lane Configurations		↕			↕			↕			↕	
Traffic Vol, veh/h	2	37	8	22	43	1	5	6	10	0	5	7
Future Vol, veh/h	2	37	8	22	43	1	5	6	10	0	5	7
Conflicting Peds, #/hr	0	0	0	0	0	0	0	0	0	0	0	0
Sign Control	Stop	Stop	Stop	Stop	Stop	Stop	Free	Free	Free	Free	Free	Free
RT Channelized	-	-	None	-	-	None	-	-	None	-	-	None
Storage Length	-	-	-	-	-	-	-	-	-	-	-	-
Veh in Median Storage, #	-	0	-	-	0	-	-	0	-	-	0	-
Grade, %	-	0	-	-	0	-	-	0	-	-	0	-
Peak Hour Factor	79	79	79	79	79	79	79	79	79	79	79	79
Heavy Vehicles, %	2	2	2	2	2	2	2	2	2	2	2	2
Mvmt Flow	3	47	10	28	54	1	6	8	13	0	6	9

Major/Minor	Minor2		Minor1		Major1			Major2				
Conflicting Flow All	65	44	11	66	42	15	15	0	0	21	0	0
Stage 1	11	11	-	27	27	-	-	-	-	-	-	-
Stage 2	54	33	-	39	15	-	-	-	-	-	-	-
Critical Hdwy	7.12	6.52	6.22	7.12	6.52	6.22	4.12	-	-	4.12	-	-
Critical Hdwy Stg 1	6.12	5.52	-	6.12	5.52	-	-	-	-	-	-	-
Critical Hdwy Stg 2	6.12	5.52	-	6.12	5.52	-	-	-	-	-	-	-
Follow-up Hdwy	3.518	4.018	3.318	3.518	4.018	3.318	2.218	-	-	2.218	-	-
Pot Cap-1 Maneuver	929	848	1070	927	850	1065	1603	-	-	1595	-	-
Stage 1	1010	886	-	990	873	-	-	-	-	-	-	-
Stage 2	958	868	-	976	883	-	-	-	-	-	-	-
Platoon blocked, %								-	-	-	-	-
Mov Cap-1 Maneuver	880	845	1070	877	847	1065	1603	-	-	1595	-	-
Mov Cap-2 Maneuver	880	845	-	877	847	-	-	-	-	-	-	-
Stage 1	1006	886	-	986	870	-	-	-	-	-	-	-
Stage 2	893	865	-	916	883	-	-	-	-	-	-	-

Approach	EB		WB		NB		SB	
HCM Control Delay, s	9.4		9.6		1.7		0	
HCM LOS	A		A					

Minor Lane/Major Mvmt	NBL	NBT	NBR	EBLn1	WBLn1	SBL	SBT	SBR
Capacity (veh/h)	1603	-	-	878	859	1595	-	-
HCM Lane V/C Ratio	0.004	-	-	0.068	0.097	-	-	-
HCM Control Delay (s)	7.3	0	-	9.4	9.6	0	-	-
HCM Lane LOS	A	A	-	A	A	A	-	-
HCM 95th %tile Q(veh)	0	-	-	0.2	0.3	0	-	-

Heritage at Dalia Ranch
6: Imperial Ave & Worthington Rd/Barioni Blvd

Existing Conditions
Timing Plan: PM PEAK

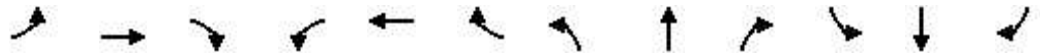

Movement	EBL	EBT	EBR	WBL	WBT	WBR	NBL	NBT	NBR	SBL	SBT	SBR
Lane Configurations		↖	↗		↖	↗	↖	↕		↖	↕	
Traffic Volume (veh/h)	47	72	102	53	109	50	109	648	14	26	577	61
Future Volume (veh/h)	47	72	102	53	109	50	109	648	14	26	577	61
Initial Q (Qb), veh	0	0	0	0	0	0	0	0	0	0	0	0
Ped-Bike Adj(A_pbT)	1.00		1.00	1.00		1.00	1.00		1.00	1.00		1.00
Parking Bus, Adj	1.00	1.00	1.00	1.00	1.00	1.00	1.00	1.00	1.00	1.00	1.00	1.00
Work Zone On Approach		No			No			No			No	
Adj Sat Flow, veh/h/ln	1870	1870	1870	1870	1870	1870	1870	1870	1870	1870	1870	1870
Adj Flow Rate, veh/h	52	79	112	58	120	55	120	712	15	29	634	67
Peak Hour Factor	0.91	0.91	0.91	0.91	0.91	0.91	0.91	0.91	0.91	0.91	0.91	0.91
Percent Heavy Veh, %	2	2	2	2	2	2	2	2	2	2	2	2
Cap, veh/h	87	131	188	85	176	225	154	1132	24	59	859	91
Arrive On Green	0.12	0.12	0.12	0.14	0.14	0.14	0.09	0.32	0.32	0.03	0.26	0.26
Sat Flow, veh/h	728	1106	1585	600	1241	1585	1781	3559	75	1781	3243	342
Grp Volume(v), veh/h	131	0	112	178	0	55	120	355	372	29	347	354
Grp Sat Flow(s),veh/h/ln	1834	0	1585	1840	0	1585	1781	1777	1857	1781	1777	1809
Q Serve(g_s), s	3.5	0.0	3.4	4.7	0.0	1.6	3.4	8.8	8.8	0.8	9.2	9.2
Cycle Q Clear(g_c), s	3.5	0.0	3.4	4.7	0.0	1.6	3.4	8.8	8.8	0.8	9.2	9.2
Prop In Lane	0.40		1.00	0.33		1.00	1.00		0.04	1.00		0.19
Lane Grp Cap(c), veh/h	218	0	188	261	0	225	154	565	591	59	470	479
V/C Ratio(X)	0.60	0.00	0.59	0.68	0.00	0.24	0.78	0.63	0.63	0.49	0.74	0.74
Avail Cap(c_a), veh/h	641	0	554	643	0	554	208	656	685	173	621	632
HCM Platoon Ratio	1.00	1.00	1.00	1.00	1.00	1.00	1.00	1.00	1.00	1.00	1.00	1.00
Upstream Filter(I)	1.00	0.00	1.00	1.00	0.00	1.00	1.00	1.00	1.00	1.00	1.00	1.00
Uniform Delay (d), s/veh	21.5	0.0	21.5	21.0	0.0	19.6	23.0	15.0	15.0	24.5	17.3	17.3
Incr Delay (d2), s/veh	2.6	0.0	3.0	3.1	0.0	0.6	12.5	1.5	1.4	6.3	3.2	3.2
Initial Q Delay(d3),s/veh	0.0	0.0	0.0	0.0	0.0	0.0	0.0	0.0	0.0	0.0	0.0	0.0
%ile BackOfQ(50%),veh/ln	1.5	0.0	1.3	2.1	0.0	0.6	1.8	3.3	3.4	0.4	3.7	3.8
Unsig. Movement Delay, s/veh												
LnGrp Delay(d),s/veh	24.2	0.0	24.5	24.1	0.0	20.2	35.6	16.5	16.4	30.8	20.5	20.5
LnGrp LOS	C	A	C	C	A	C	D	B	B	C	C	C
Approach Vol, veh/h		243			233			847			730	
Approach Delay, s/veh		24.3			23.2			19.2			20.9	
Approach LOS		C			C			B			C	
Timer - Assigned Phs	1	2		4	5	6		8				
Phs Duration (G+Y+Rc), s	6.7	21.4		11.1	9.4	18.6		12.3				
Change Period (Y+Rc), s	5.0	5.0		5.0	5.0	5.0		5.0				
Max Green Setting (Gmax), s	5.0	19.0		18.0	6.0	18.0		18.0				
Max Q Clear Time (g_c+I1), s	2.8	10.8		5.5	5.4	11.2		6.7				
Green Ext Time (p_c), s	0.0	2.9		0.8	0.0	2.4		0.8				
Intersection Summary												
HCM 6th Ctrl Delay				20.9								
HCM 6th LOS				C								

Heritage at Dalia Ranch
7: La Brucherie Rd & Worthington Rd

Existing Conditions
Timing Plan: PM PEAK

Intersection												
Intersection Delay, s/veh	10.4											
Intersection LOS	B											

Movement	EBL	EBT	EBR	WBL	WBT	WBR	NBL	NBT	NBR	SBL	SBT	SBR
Lane Configurations		↔	↔		↔	↔		↔			↔	
Traffic Vol, veh/h	25	182	32	26	209	33	1	0	0	36	5	23
Future Vol, veh/h	25	182	32	26	209	33	1	0	0	36	5	23
Peak Hour Factor	0.80	0.80	0.80	0.80	0.80	0.80	0.80	0.80	0.80	0.80	0.80	0.80
Heavy Vehicles, %	2	2	2	2	2	2	2	2	2	2	2	2
Mvmt Flow	31	228	40	33	261	41	1	0	0	45	6	29
Number of Lanes	0	1	1	0	1	1	0	1	0	0	1	0

Approach	EB	WB	NB	SB
Opposing Approach	WB	EB	SB	NB
Opposing Lanes	2	2	1	1
Conflicting Approach Left	SB	NB	EB	WB
Conflicting Lanes Left	1	1	2	2
Conflicting Approach Right	NB	SB	WB	EB
Conflicting Lanes Right	1	1	2	2
HCM Control Delay	10.3	10.8	8.8	9
HCM LOS	B	B	A	A

Lane	NBLn1	EBLn1	EBLn2	WBLn1	WBLn2	SBLn1
Vol Left, %	100%	12%	0%	11%	0%	56%
Vol Thru, %	0%	88%	0%	89%	0%	8%
Vol Right, %	0%	0%	100%	0%	100%	36%
Sign Control	Stop	Stop	Stop	Stop	Stop	Stop
Traffic Vol by Lane	1	207	32	235	33	64
LT Vol	1	25	0	26	0	36
Through Vol	0	182	0	209	0	5
RT Vol	0	0	32	0	33	23
Lane Flow Rate	1	259	40	294	41	80
Geometry Grp	2	7	7	7	7	2
Degree of Util (X)	0.002	0.366	0.048	0.412	0.049	0.117
Departure Headway (Hd)	5.73	5.09	4.326	5.055	4.296	5.281
Convergence, Y/N	Yes	Yes	Yes	Yes	Yes	Yes
Cap	622	706	827	711	832	677
Service Time	3.792	2.823	2.058	2.788	2.028	3.326
HCM Lane V/C Ratio	0.002	0.367	0.048	0.414	0.049	0.118
HCM Control Delay	8.8	10.8	7.3	11.3	7.3	9
HCM Lane LOS	A	B	A	B	A	A
HCM 95th-tile Q	0	1.7	0.2	2	0.2	0.4

Heritage at Dalia Ranch
8: Imperial Ave & Aten Rd

Existing Conditions
Timing Plan: PM PEAK



Movement	EBL	EBT	EBR	WBL	WBT	WBR	NBL	NBT	NBR	SBL	SBT	SBR
Lane Configurations	↖	↑↑		↖	↑↑		↖	↑↑	↖	↖	↑↑	↖
Traffic Volume (veh/h)	184	268	66	173	280	119	76	646	145	109	523	203
Future Volume (veh/h)	184	268	66	173	280	119	76	646	145	109	523	203
Initial Q (Qb), veh	0	0	0	0	0	0	0	0	0	0	0	0
Ped-Bike Adj(A_pbT)	1.00		1.00	1.00		1.00	1.00		1.00	1.00		1.00
Parking Bus, Adj	1.00	1.00	1.00	1.00	1.00	1.00	1.00	1.00	1.00	1.00	1.00	1.00
Work Zone On Approach		No		No		No		No		No		No
Adj Sat Flow, veh/h/ln	1870	1870	1870	1870	1870	1870	1870	1870	1870	1870	1870	1870
Adj Flow Rate, veh/h	196	285	70	184	298	127	81	687	154	116	556	216
Peak Hour Factor	0.94	0.94	0.94	0.94	0.94	0.94	0.94	0.94	0.94	0.94	0.94	0.94
Percent Heavy Veh, %	2	2	2	2	2	2	2	2	2	2	2	2
Cap, veh/h	244	532	128	231	440	183	111	921	411	149	996	444
Arrive On Green	0.14	0.19	0.19	0.13	0.18	0.18	0.06	0.26	0.26	0.08	0.28	0.28
Sat Flow, veh/h	1781	2838	686	1781	2445	1019	1781	3554	1585	1781	3554	1585
Grp Volume(v), veh/h	196	177	178	184	215	210	81	687	154	116	556	216
Grp Sat Flow(s),veh/h/ln	1781	1777	1747	1781	1777	1687	1781	1777	1585	1781	1777	1585
Q Serve(g_s), s	6.3	5.3	5.4	5.9	6.6	6.9	2.6	10.4	4.7	3.8	7.8	6.7
Cycle Q Clear(g_c), s	6.3	5.3	5.4	5.9	6.6	6.9	2.6	10.4	4.7	3.8	7.8	6.7
Prop In Lane	1.00		0.39	1.00		0.60	1.00		1.00	1.00		1.00
Lane Grp Cap(c), veh/h	244	333	327	231	320	304	111	921	411	149	996	444
V/C Ratio(X)	0.80	0.53	0.55	0.80	0.67	0.69	0.73	0.75	0.37	0.78	0.56	0.49
Avail Cap(c_a), veh/h	333	544	535	333	544	516	182	1148	512	212	1209	539
HCM Platoon Ratio	1.00	1.00	1.00	1.00	1.00	1.00	1.00	1.00	1.00	1.00	1.00	1.00
Upstream Filter(l)	1.00	1.00	1.00	1.00	1.00	1.00	1.00	1.00	1.00	1.00	1.00	1.00
Uniform Delay (d), s/veh	24.6	21.6	21.6	24.8	22.5	22.6	27.1	20.0	17.9	26.4	18.1	17.6
Incr Delay (d2), s/veh	9.5	1.3	1.4	8.3	2.4	2.8	8.8	2.1	0.6	11.1	0.5	0.8
Initial Q Delay(d3),s/veh	0.0	0.0	0.0	0.0	0.0	0.0	0.0	0.0	0.0	0.0	0.0	0.0
%ile BackOfQ(50%),veh/ln	3.1	2.2	2.2	2.9	2.8	2.8	1.3	4.2	1.6	2.0	3.0	2.3
Unsig. Movement Delay, s/veh												
LnGrp Delay(d),s/veh	34.1	22.9	23.0	33.1	24.9	25.4	35.9	22.1	18.4	37.5	18.5	18.5
LnGrp LOS	C	C	C	C	C	C	D	C	B	D	B	B
Approach Vol, veh/h		551			609			922			888	
Approach Delay, s/veh		26.9			27.6			22.7			21.0	
Approach LOS		C			C			C			C	
Timer - Assigned Phs	1	2	3	4	5	6	7	8				
Phs Duration (G+Y+Rc), s	9.9	20.2	12.6	16.0	8.7	21.5	13.1	15.6				
Change Period (Y+Rc), s	5.0	5.0	5.0	5.0	5.0	5.0	5.0	5.0				
Max Green Setting (Gmax), s	19.0	19.0	11.0	18.0	6.0	20.0	11.0	18.0				
Max Q Clear Time (g_c+1/3), s	12.4	12.4	7.9	7.4	4.6	9.8	8.3	8.9				
Green Ext Time (p_c), s	0.0	2.8	0.1	1.5	0.0	3.3	0.1	1.7				
Intersection Summary												
HCM 6th Ctrl Delay				24.0								
HCM 6th LOS				C								

Heritage at Dalia Ranch
1: SR-86 & Keystone Rd

Opening Year 2023
Timing Plan: AM PEAK

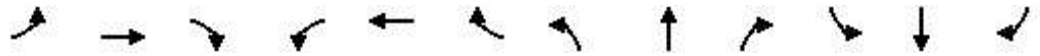

Movement	EBL	EBT	EBR	WBL	WBT	WBR	NBL	NBT	NBR	SBL	SBT	SBR
Lane Configurations		↕↕			↕↕		↕	↕↕	↕	↕	↕↕	↕
Traffic Volume (veh/h)	33	33	11	19	24	42	19	439	49	45	512	37
Future Volume (veh/h)	33	33	11	19	24	42	19	439	49	45	512	37
Initial Q (Qb), veh	0	0	0	0	0	0	0	0	0	0	0	0
Ped-Bike Adj(A_pbT)	1.00		1.00	1.00		1.00	1.00		1.00	1.00		1.00
Parking Bus, Adj	1.00	1.00	1.00	1.00	1.00	1.00	1.00	1.00	1.00	1.00	1.00	1.00
Work Zone On Approach		No			No			No			No	
Adj Sat Flow, veh/h/ln	1870	1870	1870	1870	1870	1870	1870	1870	1870	1870	1870	1870
Adj Flow Rate, veh/h	37	37	12	21	27	47	21	488	54	50	569	41
Peak Hour Factor	0.90	0.90	0.90	0.90	0.90	0.90	0.90	0.90	0.90	0.90	0.90	0.90
Percent Heavy Veh, %	2	2	2	2	2	2	2	2	2	2	2	2
Cap, veh/h	261	111	31	191	74	109	48	1003	447	102	1111	496
Arrive On Green	0.13	0.13	0.13	0.13	0.13	0.13	0.03	0.28	0.28	0.06	0.31	0.31
Sat Flow, veh/h	598	829	231	276	556	814	1781	3554	1585	1781	3554	1585
Grp Volume(v), veh/h	86	0	0	95	0	0	21	488	54	50	569	41
Grp Sat Flow(s),veh/h/ln	1659	0	0	1646	0	0	1781	1777	1585	1781	1777	1585
Q Serve(g_s), s	0.0	0.0	0.0	0.2	0.0	0.0	0.3	3.3	0.7	0.8	3.7	0.5
Cycle Q Clear(g_c), s	1.2	0.0	0.0	1.4	0.0	0.0	0.3	3.3	0.7	0.8	3.7	0.5
Prop In Lane	0.43		0.14	0.22		0.49	1.00		1.00	1.00		1.00
Lane Grp Cap(c), veh/h	403	0	0	374	0	0	48	1003	447	102	1111	496
V/C Ratio(X)	0.21	0.00	0.00	0.25	0.00	0.00	0.44	0.49	0.12	0.49	0.51	0.08
Avail Cap(c_a), veh/h	1178	0	0	1169	0	0	313	2247	1002	313	2247	1002
HCM Platoon Ratio	1.00	1.00	1.00	1.00	1.00	1.00	1.00	1.00	1.00	1.00	1.00	1.00
Upstream Filter(l)	1.00	0.00	0.00	1.00	0.00	0.00	1.00	1.00	1.00	1.00	1.00	1.00
Uniform Delay (d), s/veh	11.2	0.0	0.0	11.3	0.0	0.0	13.6	8.5	7.6	13.0	8.0	6.9
Incr Delay (d2), s/veh	0.3	0.0	0.0	0.4	0.0	0.0	6.2	0.4	0.1	3.6	0.4	0.1
Initial Q Delay(d3),s/veh	0.0	0.0	0.0	0.0	0.0	0.0	0.0	0.0	0.0	0.0	0.0	0.0
%ile BackOfQ(50%),veh/ln	0.4	0.0	0.0	0.4	0.0	0.0	0.2	0.8	0.2	0.3	0.9	0.1
Unsig. Movement Delay, s/veh												
LnGrp Delay(d),s/veh	11.5	0.0	0.0	11.7	0.0	0.0	19.8	8.9	7.7	16.6	8.4	7.0
LnGrp LOS	B	A	A	B	A	A	B	A	A	B	A	A
Approach Vol, veh/h		86			95			563			660	
Approach Delay, s/veh		11.5			11.7			9.2			8.9	
Approach LOS		B			B			A			A	
Timer - Assigned Phs	1	2		4	5	6		8				
Phs Duration (G+Y+Rc), s	6.6	13.0		8.8	5.8	13.9		8.8				
Change Period (Y+Rc), s	5.0	5.0		5.0	5.0	5.0		5.0				
Max Green Setting (Gmax), s	5.0	18.0		18.0	5.0	18.0		18.0				
Max Q Clear Time (g_c+I1), s	2.8	5.3		3.2	2.3	5.7		3.4				
Green Ext Time (p_c), s	0.0	2.8		0.3	0.0	3.2		0.4				
Intersection Summary												
HCM 6th Ctrl Delay				9.4								
HCM 6th LOS				A								

Intersection												
Int Delay, s/veh	0.4											
Movement	EBL	EBT	EBR	WBL	WBT	WBR	NBL	NBT	NBR	SBL	SBT	SBR
Lane Configurations		↕			↕		↕	↕		↕	↕	
Traffic Vol, veh/h	20	3	2	1	2	5	0	506	1	1	517	7
Future Vol, veh/h	20	3	2	1	2	5	0	506	1	1	517	7
Conflicting Peds, #/hr	0	0	0	0	0	0	0	0	0	0	0	0
Sign Control	Stop	Stop	Stop	Stop	Stop	Stop	Free	Free	Free	Free	Free	Free
RT Channelized	-	-	None	-	-	None	-	-	None	-	-	None
Storage Length	-	-	-	-	-	-	50	-	-	50	-	-
Veh in Median Storage, #	-	1	-	-	1	-	-	0	-	-	0	-
Grade, %	-	0	-	-	0	-	-	0	-	-	0	-
Peak Hour Factor	94	94	94	94	94	94	94	94	94	94	94	94
Heavy Vehicles, %	2	2	2	2	2	2	2	2	2	2	2	2
Mvmt Flow	21	3	2	1	2	5	0	538	1	1	550	7

Major/Minor	Minor2		Minor1			Major1			Major2			
Conflicting Flow All	826	1095	279	818	1098	270	557	0	0	539	0	0
Stage 1	556	556	-	539	539	-	-	-	-	-	-	-
Stage 2	270	539	-	279	559	-	-	-	-	-	-	-
Critical Hdwy	7.54	6.54	6.94	7.54	6.54	6.94	4.14	-	-	4.14	-	-
Critical Hdwy Stg 1	6.54	5.54	-	6.54	5.54	-	-	-	-	-	-	-
Critical Hdwy Stg 2	6.54	5.54	-	6.54	5.54	-	-	-	-	-	-	-
Follow-up Hdwy	3.52	4.02	3.32	3.52	4.02	3.32	2.22	-	-	2.22	-	-
Pot Cap-1 Maneuver	264	212	718	268	211	728	1010	-	-	1025	-	-
Stage 1	483	511	-	494	520	-	-	-	-	-	-	-
Stage 2	713	520	-	704	509	-	-	-	-	-	-	-
Platoon blocked, %								-	-	-	-	-
Mov Cap-1 Maneuver	261	212	718	265	211	728	1010	-	-	1025	-	-
Mov Cap-2 Maneuver	373	332	-	379	331	-	-	-	-	-	-	-
Stage 1	483	510	-	494	520	-	-	-	-	-	-	-
Stage 2	705	520	-	697	508	-	-	-	-	-	-	-

Approach	EB		WB			NB			SB		
HCM Control Delay, s	15.1		12.1			0			0		
HCM LOS	C		B								

Minor Lane/Major Mvmt	NBL	NBT	NBR	EBLn1	WBLn1	SBL	SBT	SBR
Capacity (veh/h)	1010	-	-	382	515	1025	-	-
HCM Lane V/C Ratio	-	-	-	0.07	0.017	0.001	-	-
HCM Control Delay (s)	0	-	-	15.1	12.1	8.5	-	-
HCM Lane LOS	A	-	-	C	B	A	-	-
HCM 95th %tile Q(veh)	0	-	-	0.2	0.1	0	-	-

Intersection						
Int Delay, s/veh	1.5					
Movement	WBL	WBR	NBT	NBR	SBL	SBT
Lane Configurations	↔		↑↓		↔	↑↑
Traffic Vol, veh/h	59	23	484	41	20	500
Future Vol, veh/h	59	23	484	41	20	500
Conflicting Peds, #/hr	0	0	0	0	0	0
Sign Control	Stop	Stop	Free	Free	Free	Free
RT Channelized	-	None	-	None	-	None
Storage Length	0	-	-	-	140	-
Veh in Median Storage, #	0	-	0	-	-	0
Grade, %	0	-	0	-	-	0
Peak Hour Factor	91	91	91	91	91	91
Heavy Vehicles, %	2	2	2	2	2	2
Mvmt Flow	65	25	532	45	22	549

Major/Minor	Minor1	Major1	Major2			
Conflicting Flow All	874	289	0	0	577	0
Stage 1	555	-	-	-	-	-
Stage 2	319	-	-	-	-	-
Critical Hdwy	6.84	6.94	-	-	4.14	-
Critical Hdwy Stg 1	5.84	-	-	-	-	-
Critical Hdwy Stg 2	5.84	-	-	-	-	-
Follow-up Hdwy	3.52	3.32	-	-	2.22	-
Pot Cap-1 Maneuver	289	708	-	-	993	-
Stage 1	539	-	-	-	-	-
Stage 2	710	-	-	-	-	-
Platoon blocked, %			-	-		
Mov Cap-1 Maneuver	283	708	-	-	993	-
Mov Cap-2 Maneuver	283	-	-	-	-	-
Stage 1	539	-	-	-	-	-
Stage 2	694	-	-	-	-	-

Approach	WB	NB	SB
HCM Control Delay, s	19.4	0	0.3
HCM LOS	C		

Minor Lane/Major Mvmt	NBT	NBRWBLn1	SBL	SBT
Capacity (veh/h)	-	-	340	993
HCM Lane V/C Ratio	-	-	0.265	0.022
HCM Control Delay (s)	-	-	19.4	8.7
HCM Lane LOS	-	-	C	A
HCM 95th %tile Q(veh)	-	-	1	0.1

Heritage at Dalia Ranch
4: Imperial Ave & Neckel Rd

Opening Year 2023
Timing Plan: AM PEAK



Movement	EBL	EBT	EBR	WBL	WBT	WBR	NBL	NBT	NBR	SBL	SBT	SBR
Lane Configurations		↕			↕		↕	↕		↕	↕	
Traffic Volume (veh/h)	34	43	12	142	64	56	8	442	65	14	511	31
Future Volume (veh/h)	34	43	12	142	64	56	8	442	65	14	511	31
Initial Q (Qb), veh	0	0	0	0	0	0	0	0	0	0	0	0
Ped-Bike Adj(A_pbT)	1.00		1.00	1.00		1.00	1.00		1.00	1.00		1.00
Parking Bus, Adj	1.00	1.00	1.00	1.00	1.00	1.00	1.00	1.00	1.00	1.00	1.00	1.00
Work Zone On Approach		No			No			No			No	
Adj Sat Flow, veh/h/ln	1870	1870	1870	1870	1870	1870	1870	1870	1870	1870	1870	1870
Adj Flow Rate, veh/h	37	47	13	156	70	62	9	486	71	15	562	34
Peak Hour Factor	0.91	0.91	0.91	0.91	0.91	0.91	0.91	0.91	0.91	0.91	0.91	0.91
Percent Heavy Veh, %	2	2	2	2	2	2	2	2	2	2	2	2
Cap, veh/h	53	68	19	206	92	82	21	759	110	34	855	52
Arrive On Green	0.08	0.08	0.08	0.22	0.22	0.22	0.01	0.24	0.24	0.02	0.25	0.25
Sat Flow, veh/h	684	869	240	951	427	378	1781	3113	453	1781	3405	206
Grp Volume(v), veh/h	97	0	0	288	0	0	9	276	281	15	293	303
Grp Sat Flow(s),veh/h/ln	1793	0	0	1755	0	0	1781	1777	1789	1781	1777	1833
Q Serve(g_s), s	2.4	0.0	0.0	7.0	0.0	0.0	0.2	6.3	6.4	0.4	6.7	6.7
Cycle Q Clear(g_c), s	2.4	0.0	0.0	7.0	0.0	0.0	0.2	6.3	6.4	0.4	6.7	6.7
Prop In Lane	0.38		0.13	0.54		0.22	1.00		0.25	1.00		0.11
Lane Grp Cap(c), veh/h	140	0	0	380	0	0	21	433	436	34	446	460
V/C Ratio(X)	0.69	0.00	0.00	0.76	0.00	0.00	0.43	0.64	0.64	0.44	0.66	0.66
Avail Cap(c_a), veh/h	714	0	0	699	0	0	197	747	752	197	747	771
HCM Platoon Ratio	1.00	1.00	1.00	1.00	1.00	1.00	1.00	1.00	1.00	1.00	1.00	1.00
Upstream Filter(l)	1.00	0.00	0.00	1.00	0.00	0.00	1.00	1.00	1.00	1.00	1.00	1.00
Uniform Delay (d), s/veh	20.3	0.0	0.0	16.6	0.0	0.0	22.2	15.3	15.3	21.9	15.2	15.2
Incr Delay (d2), s/veh	6.1	0.0	0.0	3.1	0.0	0.0	13.1	1.6	1.6	8.8	1.6	1.6
Initial Q Delay(d3),s/veh	0.0	0.0	0.0	0.0	0.0	0.0	0.0	0.0	0.0	0.0	0.0	0.0
%ile BackOfQ(50%),veh/ln	1.1	0.0	0.0	2.7	0.0	0.0	0.2	2.3	2.4	0.2	2.5	2.6
Unsig. Movement Delay, s/veh												
LnGrp Delay(d),s/veh	26.4	0.0	0.0	19.7	0.0	0.0	35.3	16.9	16.9	30.8	16.8	16.8
LnGrp LOS	C	A	A	B	A	A	D	B	B	C	B	B
Approach Vol, veh/h		97			288			566				611
Approach Delay, s/veh		26.4			19.7			17.2				17.2
Approach LOS		C			B			B				B
Timer - Assigned Phs	1	2		4	5	6		8				
Phs Duration (G+Y+Rc), s	5.9	16.0		8.5	5.5	16.3		14.8				
Change Period (Y+Rc), s	5.0	5.0		5.0	5.0	5.0		5.0				
Max Green Setting (Gmax), s	5.0	19.0		18.0	5.0	19.0		18.0				
Max Q Clear Time (g_c+I1), s	2.4	8.4		4.4	2.2	8.7		9.0				
Green Ext Time (p_c), s	0.0	2.5		0.3	0.0	2.6		1.1				
Intersection Summary												
HCM 6th Ctrl Delay				18.2								
HCM 6th LOS				B								

Intersection												
Int Delay, s/veh	7.6											
Movement	EBL	EBT	EBR	WBL	WBT	WBR	NBL	NBT	NBR	SBL	SBT	SBR
Lane Configurations		↕			↕			↕			↕	
Traffic Vol, veh/h	4	41	23	60	44	0	7	6	42	1	2	1
Future Vol, veh/h	4	41	23	60	44	0	7	6	42	1	2	1
Conflicting Peds, #/hr	0	0	0	0	0	0	0	0	0	0	0	0
Sign Control	Stop	Stop	Stop	Stop	Stop	Stop	Free	Free	Free	Free	Free	Free
RT Channelized	-	-	None	-	-	None	-	-	None	-	-	None
Storage Length	-	-	-	-	-	-	-	-	-	-	-	-
Veh in Median Storage, #	-	0	-	-	0	-	-	0	-	-	0	-
Grade, %	-	0	-	-	0	-	-	0	-	-	0	-
Peak Hour Factor	79	79	79	79	79	79	79	79	79	79	79	79
Heavy Vehicles, %	2	2	2	2	2	2	2	2	2	2	2	2
Mvmt Flow	5	52	29	76	56	0	9	8	53	1	3	1

Major/Minor	Minor2		Minor1		Major1			Major2				
Conflicting Flow All	87	85	4	99	59	35	4	0	0	61	0	0
Stage 1	6	6	-	53	53	-	-	-	-	-	-	-
Stage 2	81	79	-	46	6	-	-	-	-	-	-	-
Critical Hdwy	7.12	6.52	6.22	7.12	6.52	6.22	4.12	-	-	4.12	-	-
Critical Hdwy Stg 1	6.12	5.52	-	6.12	5.52	-	-	-	-	-	-	-
Critical Hdwy Stg 2	6.12	5.52	-	6.12	5.52	-	-	-	-	-	-	-
Follow-up Hdwy	3.518	4.018	3.318	3.518	4.018	3.318	2.218	-	-	2.218	-	-
Pot Cap-1 Maneuver	899	805	1080	883	832	1038	1618	-	-	1542	-	-
Stage 1	1016	891	-	960	851	-	-	-	-	-	-	-
Stage 2	927	829	-	968	891	-	-	-	-	-	-	-
Platoon blocked, %								-	-	-	-	-
Mov Cap-1 Maneuver	848	799	1080	812	826	1038	1618	-	-	1542	-	-
Mov Cap-2 Maneuver	848	799	-	812	826	-	-	-	-	-	-	-
Stage 1	1010	890	-	954	846	-	-	-	-	-	-	-
Stage 2	861	824	-	886	890	-	-	-	-	-	-	-

Approach	EB		WB		NB		SB	
HCM Control Delay, s	9.5		10.2		0.9		1.8	
HCM LOS	A		B					

Minor Lane/Major Mvmt	NBL	NBT	NBR	EBLn1	WBLn1	SBL	SBT	SBR
Capacity (veh/h)	1618	-	-	879	818	1542	-	-
HCM Lane V/C Ratio	0.005	-	-	0.098	0.161	0.001	-	-
HCM Control Delay (s)	7.2	0	-	9.5	10.2	7.3	0	-
HCM Lane LOS	A	A	-	A	B	A	A	-
HCM 95th %tile Q(veh)	0	-	-	0.3	0.6	0	-	-

Heritage at Dalia Ranch
6: Imperial Ave & Worthington Rd/Barioni Blvd

Opening Year 2023
Timing Plan: AM PEAK

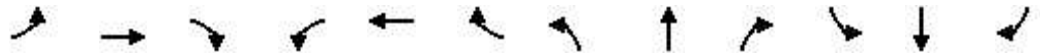

Movement	EBL	EBT	EBR	WBL	WBT	WBR	NBL	NBT	NBR	SBL	SBT	SBR
Lane Configurations		↕	↗		↕	↗	↗	↕↗		↗	↕↗	
Traffic Volume (veh/h)	70	136	212	54	132	77	93	465	50	39	630	56
Future Volume (veh/h)	70	136	212	54	132	77	93	465	50	39	630	56
Initial Q (Qb), veh	0	0	0	0	0	0	0	0	0	0	0	0
Ped-Bike Adj(A_pbT)	1.00		1.00	1.00		1.00	1.00		1.00	1.00		1.00
Parking Bus, Adj	1.00	1.00	1.00	1.00	1.00	1.00	1.00	1.00	1.00	1.00	1.00	1.00
Work Zone On Approach		No			No			No			No	
Adj Sat Flow, veh/h/ln	1870	1870	1870	1870	1870	1870	1870	1870	1870	1870	1870	1870
Adj Flow Rate, veh/h	79	153	238	61	148	87	104	522	56	44	708	63
Peak Hour Factor	0.89	0.89	0.89	0.89	0.89	0.89	0.89	0.89	0.89	0.89	0.89	0.89
Percent Heavy Veh, %	2	2	2	2	2	2	2	2	2	2	2	2
Cap, veh/h	122	235	308	83	201	244	133	953	102	76	865	77
Arrive On Green	0.19	0.19	0.19	0.15	0.15	0.15	0.07	0.29	0.29	0.04	0.26	0.26
Sat Flow, veh/h	626	1213	1585	538	1305	1585	1781	3238	346	1781	3301	294
Grp Volume(v), veh/h	232	0	238	209	0	87	104	286	292	44	381	390
Grp Sat Flow(s),veh/h/ln	1839	0	1585	1843	0	1585	1781	1777	1808	1781	1777	1818
Q Serve(g_s), s	7.4	0.0	9.0	6.9	0.0	3.1	3.6	8.6	8.6	1.5	12.8	12.8
Cycle Q Clear(g_c), s	7.4	0.0	9.0	6.9	0.0	3.1	3.6	8.6	8.6	1.5	12.8	12.8
Prop In Lane	0.34		1.00	0.29		1.00	1.00		0.19	1.00		0.16
Lane Grp Cap(c), veh/h	357	0	308	284	0	244	133	523	532	76	466	476
V/C Ratio(X)	0.65	0.00	0.77	0.74	0.00	0.36	0.78	0.55	0.55	0.58	0.82	0.82
Avail Cap(c_a), veh/h	522	0	449	523	0	449	140	532	541	140	532	544
HCM Platoon Ratio	1.00	1.00	1.00	1.00	1.00	1.00	1.00	1.00	1.00	1.00	1.00	1.00
Upstream Filter(I)	1.00	0.00	1.00	1.00	0.00	1.00	1.00	1.00	1.00	1.00	1.00	1.00
Uniform Delay (d), s/veh	23.6	0.0	24.3	25.6	0.0	24.0	28.9	18.8	18.9	29.8	22.0	22.0
Incr Delay (d2), s/veh	2.0	0.0	5.0	3.7	0.0	0.9	23.3	1.1	1.1	6.9	8.7	8.6
Initial Q Delay(d3),s/veh	0.0	0.0	0.0	0.0	0.0	0.0	0.0	0.0	0.0	0.0	0.0	0.0
%ile BackOfQ(50%),veh/ln	3.2	0.0	3.6	3.1	0.0	1.2	2.3	3.4	3.5	0.8	6.0	6.2
Unsig. Movement Delay, s/veh												
LnGrp Delay(d),s/veh	25.6	0.0	29.3	29.3	0.0	24.9	52.1	20.0	20.0	36.7	30.7	30.6
LnGrp LOS	C	A	C	C	A	C	D	B	B	D	C	C
Approach Vol, veh/h		470			296			682				815
Approach Delay, s/veh		27.4			28.0			24.9				31.0
Approach LOS		C			C			C				C
Timer - Assigned Phs	1	2		4	5	6		8				
Phs Duration (G+Y+Rc), s	7.7	23.7		17.3	9.7	21.6		14.8				
Change Period (Y+Rc), s	5.0	5.0		5.0	5.0	5.0		5.0				
Max Green Setting (Gmax), s	5.0	19.0		18.0	5.0	19.0		18.0				
Max Q Clear Time (g_c+I1), s	3.5	10.6		11.0	5.6	14.8		8.9				
Green Ext Time (p_c), s	0.0	2.3		1.3	0.0	1.8		1.0				
Intersection Summary												
HCM 6th Ctrl Delay				28.0								
HCM 6th LOS				C								

Intersection

Intersection Delay, s/veh 19.3

Intersection LOS C

Movement	EBL	EBT	EBR	WBL	WBT	WBR	NBL	NBT	NBR	SBL	SBT	SBR
Lane Configurations		↔	↔		↔	↔		↔			↔	
Traffic Vol, veh/h	61	390	119	11	301	77	0	0	1	106	31	64
Future Vol, veh/h	61	390	119	11	301	77	0	0	1	106	31	64
Peak Hour Factor	0.92	0.92	0.92	0.92	0.92	0.92	0.92	0.92	0.92	0.92	0.92	0.92
Heavy Vehicles, %	2	2	2	2	2	2	2	2	2	2	2	2
Mvmt Flow	66	424	129	12	327	84	0	0	1	115	34	70
Number of Lanes	0	1	1	0	1	1	0	1	0	0	1	0

Approach	EB	WB	NB	SB
Opposing Approach	WB	EB	SB	NB
Opposing Lanes	2	2	1	1
Conflicting Approach Left	SB	NB	EB	WB
Conflicting Lanes Left	1	1	2	2
Conflicting Approach Right	NB	SB	WB	EB
Conflicting Lanes Right	1	1	2	2
HCM Control Delay	24.3	15.1	9.6	13.2
HCM LOS	C	C	A	B

Lane	NBLn1	EBLn1	EBLn2	WBLn1	WBLn2	SBLn1
Vol Left, %	0%	14%	0%	4%	0%	53%
Vol Thru, %	0%	86%	0%	96%	0%	15%
Vol Right, %	100%	0%	100%	0%	100%	32%
Sign Control	Stop	Stop	Stop	Stop	Stop	Stop
Traffic Vol by Lane	1	451	119	312	77	201
LT Vol	0	61	0	11	0	106
Through Vol	0	390	0	301	0	31
RT Vol	1	0	119	0	77	64
Lane Flow Rate	1	490	129	339	84	218
Geometry Grp	2	7	7	7	7	2
Degree of Util (X)	0.002	0.802	0.184	0.572	0.124	0.381
Departure Headway (Hd)	6.471	5.889	5.111	6.068	5.339	6.275
Convergence, Y/N	Yes	Yes	Yes	Yes	Yes	Yes
Cap	549	613	701	593	670	572
Service Time	4.559	3.629	2.851	3.815	3.086	4.328
HCM Lane V/C Ratio	0.002	0.799	0.184	0.572	0.125	0.381
HCM Control Delay	9.6	28.3	9	16.7	8.8	13.2
HCM Lane LOS	A	D	A	C	A	B
HCM 95th-tile Q	0	7.9	0.7	3.6	0.4	1.8

Heritage at Dalia Ranch
8: Imperial Ave & Aten Rd

Opening Year 2023
Timing Plan: AM PEAK



Movement	EBL	EBT	EBR	WBL	WBT	WBR	NBL	NBT	NBR	SBL	SBT	SBR
Lane Configurations												
Traffic Volume (veh/h)	186	337	63	131	299	141	61	343	67	142	670	375
Future Volume (veh/h)	186	337	63	131	299	141	61	343	67	142	670	375
Initial Q (Qb), veh	0	0	0	0	0	0	0	0	0	0	0	0
Ped-Bike Adj(A_pbT)	1.00		1.00	1.00		1.00	1.00		1.00	1.00		1.00
Parking Bus, Adj	1.00	1.00	1.00	1.00	1.00	1.00	1.00	1.00	1.00	1.00	1.00	1.00
Work Zone On Approach		No			No			No			No	
Adj Sat Flow, veh/h/ln	1870	1870	1870	1870	1870	1870	1870	1870	1870	1870	1870	1870
Adj Flow Rate, veh/h	216	392	73	152	348	164	71	399	78	165	779	436
Peak Hour Factor	0.86	0.86	0.86	0.86	0.86	0.86	0.86	0.86	0.86	0.86	0.86	0.86
Percent Heavy Veh, %	2	2	2	2	2	2	2	2	2	2	2	2
Cap, veh/h	258	700	129	191	462	214	97	893	398	204	1107	494
Arrive On Green	0.14	0.23	0.23	0.11	0.20	0.20	0.05	0.25	0.25	0.11	0.31	0.31
Sat Flow, veh/h	1781	2995	553	1781	2359	1092	1781	3554	1585	1781	3554	1585
Grp Volume(v), veh/h	216	231	234	152	261	251	71	399	78	165	779	436
Grp Sat Flow(s),veh/h/ln	1781	1777	1771	1781	1777	1674	1781	1777	1585	1781	1777	1585
Q Serve(g_s), s	8.0	7.8	7.9	5.7	9.4	9.7	2.7	6.5	2.6	6.2	13.2	17.8
Cycle Q Clear(g_c), s	8.0	7.8	7.9	5.7	9.4	9.7	2.7	6.5	2.6	6.2	13.2	17.8
Prop In Lane	1.00		0.31	1.00		0.65	1.00		1.00	1.00		1.00
Lane Grp Cap(c), veh/h	258	415	414	191	348	328	97	893	398	204	1107	494
V/C Ratio(X)	0.84	0.56	0.56	0.80	0.75	0.77	0.73	0.45	0.20	0.81	0.70	0.88
Avail Cap(c_a), veh/h	261	495	494	235	469	442	131	991	442	209	1147	512
HCM Platoon Ratio	1.00	1.00	1.00	1.00	1.00	1.00	1.00	1.00	1.00	1.00	1.00	1.00
Upstream Filter(l)	1.00	1.00	1.00	1.00	1.00	1.00	1.00	1.00	1.00	1.00	1.00	1.00
Uniform Delay (d), s/veh	28.4	23.0	23.1	29.7	25.8	25.9	31.7	21.5	20.1	29.4	20.7	22.3
Incr Delay (d2), s/veh	20.4	1.2	1.2	14.3	4.5	5.6	13.2	0.4	0.2	20.3	1.9	16.1
Initial Q Delay(d3),s/veh	0.0	0.0	0.0	0.0	0.0	0.0	0.0	0.0	0.0	0.0	0.0	0.0
%ile BackOfQ(50%),veh/ln	4.7	3.2	3.3	3.1	4.2	4.2	1.5	2.6	1.0	3.7	5.4	8.3
Unsig. Movement Delay, s/veh												
LnGrp Delay(d),s/veh	48.8	24.2	24.3	44.0	30.3	31.5	45.0	21.9	20.3	49.7	22.6	38.4
LnGrp LOS	D	C	C	D	C	C	D	C	C	D	C	D
Approach Vol, veh/h		681			664			548			1380	
Approach Delay, s/veh		32.0			33.9			24.6			30.8	
Approach LOS		C			C			C			C	
Timer - Assigned Phs	1	2	3	4	5	6	7	8				
Phs Duration (G+Y+Rc), s	22.8	22.1	12.3	20.9	8.7	26.2	14.9	18.3				
Change Period (Y+Rc), s	5.0	5.0	5.0	5.0	5.0	5.0	5.0	5.0				
Max Green Setting (Gmax), s	19.0	19.0	9.0	19.0	5.0	22.0	10.0	18.0				
Max Q Clear Time (g_c+1/2), s	8.5	8.5	7.7	9.9	4.7	19.8	10.0	11.7				
Green Ext Time (p_c), s	0.0	2.1	0.0	1.9	0.0	1.4	0.0	1.7				
Intersection Summary												
HCM 6th Ctrl Delay											30.7	
HCM 6th LOS											C	

Heritage at Dalia Ranch
1: SR-86 & Keystone Rd

Opening Year 2023
Timing Plan: PM PEAK

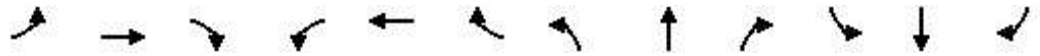

Movement	EBL	EBT	EBR	WBL	WBT	WBR	NBL	NBT	NBR	SBL	SBT	SBR
Lane Configurations		↔			↔		↗	↕	↗	↗	↕	↗
Traffic Volume (veh/h)	41	12	20	33	27	37	10	523	26	52	542	34
Future Volume (veh/h)	41	12	20	33	27	37	10	523	26	52	542	34
Initial Q (Qb), veh	0	0	0	0	0	0	0	0	0	0	0	0
Ped-Bike Adj(A_pbT)	1.00		1.00	1.00		1.00	1.00		1.00	1.00		1.00
Parking Bus, Adj	1.00	1.00	1.00	1.00	1.00	1.00	1.00	1.00	1.00	1.00	1.00	1.00
Work Zone On Approach		No			No			No			No	
Adj Sat Flow, veh/h/ln	1870	1870	1870	1870	1870	1870	1870	1870	1870	1870	1870	1870
Adj Flow Rate, veh/h	46	13	22	37	30	42	11	588	29	58	609	38
Peak Hour Factor	0.89	0.89	0.89	0.89	0.89	0.89	0.89	0.89	0.89	0.89	0.89	0.89
Percent Heavy Veh, %	2	2	2	2	2	2	2	2	2	2	2	2
Cap, veh/h	288	50	57	217	71	83	26	1127	502	113	1301	580
Arrive On Green	0.13	0.13	0.13	0.13	0.13	0.13	0.01	0.32	0.32	0.06	0.37	0.37
Sat Flow, veh/h	795	383	439	461	547	631	1781	3554	1585	1781	3554	1585
Grp Volume(v), veh/h	81	0	0	109	0	0	11	588	29	58	609	38
Grp Sat Flow(s),veh/h/ln	1617	0	0	1639	0	0	1781	1777	1585	1781	1777	1585
Q Serve(g_s), s	0.0	0.0	0.0	0.5	0.0	0.0	0.2	4.2	0.4	1.0	4.0	0.5
Cycle Q Clear(g_c), s	1.3	0.0	0.0	1.8	0.0	0.0	0.2	4.2	0.4	1.0	4.0	0.5
Prop In Lane	0.57		0.27	0.34		0.39	1.00		1.00	1.00		1.00
Lane Grp Cap(c), veh/h	395	0	0	371	0	0	26	1127	502	113	1301	580
V/C Ratio(X)	0.20	0.00	0.00	0.29	0.00	0.00	0.42	0.52	0.06	0.51	0.47	0.07
Avail Cap(c_a), veh/h	1061	0	0	1086	0	0	290	2432	1085	348	2547	1136
HCM Platoon Ratio	1.00	1.00	1.00	1.00	1.00	1.00	1.00	1.00	1.00	1.00	1.00	1.00
Upstream Filter(l)	1.00	0.00	0.00	1.00	0.00	0.00	1.00	1.00	1.00	1.00	1.00	1.00
Uniform Delay (d), s/veh	12.1	0.0	0.0	12.4	0.0	0.0	15.0	8.6	7.3	13.9	7.4	6.3
Incr Delay (d2), s/veh	0.3	0.0	0.0	0.4	0.0	0.0	10.6	0.4	0.0	3.6	0.3	0.0
Initial Q Delay(d3),s/veh	0.0	0.0	0.0	0.0	0.0	0.0	0.0	0.0	0.0	0.0	0.0	0.0
%ile BackOfQ(50%),veh/ln	0.4	0.0	0.0	0.6	0.0	0.0	0.1	1.1	0.1	0.4	1.0	0.1
Unsig. Movement Delay, s/veh												
LnGrp Delay(d),s/veh	12.4	0.0	0.0	12.8	0.0	0.0	25.6	9.0	7.3	17.5	7.7	6.4
LnGrp LOS	B	A	A	B	A	A	C	A	A	B	A	A
Approach Vol, veh/h		81			109			628			705	
Approach Delay, s/veh		12.4			12.8			9.2			8.4	
Approach LOS		B			B			A			A	
Timer - Assigned Phs	1	2		4	5	6		8				
Phs Duration (G+Y+Rc), s	7.0	14.7		9.0	5.4	16.2		9.0				
Change Period (Y+Rc), s	5.0	5.0		5.0	5.0	5.0		5.0				
Max Green Setting (Gmax), s	6.0	21.0		18.0	5.0	22.0		18.0				
Max Q Clear Time (g_c+I1), s	3.0	6.2		3.3	2.2	6.0		3.8				
Green Ext Time (p_c), s	0.0	3.6		0.3	0.0	3.9		0.4				
Intersection Summary												
HCM 6th Ctrl Delay				9.3								
HCM 6th LOS				A								

Intersection												
Int Delay, s/veh	0.3											
Movement	EBL	EBT	EBR	WBL	WBT	WBR	NBL	NBT	NBR	SBL	SBT	SBR
Lane Configurations		↕			↕		↕	↕		↕	↕	
Traffic Vol, veh/h	6	4	0	7	0	5	1	561	7	6	578	17
Future Vol, veh/h	6	4	0	7	0	5	1	561	7	6	578	17
Conflicting Peds, #/hr	0	0	0	0	0	0	0	0	0	0	0	0
Sign Control	Stop	Stop	Stop	Stop	Stop	Stop	Free	Free	Free	Free	Free	Free
RT Channelized	-	-	None	-	-	None	-	-	None	-	-	None
Storage Length	-	-	-	-	-	-	50	-	-	50	-	-
Veh in Median Storage, #	-	1	-	-	1	-	-	0	-	-	0	-
Grade, %	-	0	-	-	0	-	-	0	-	-	0	-
Peak Hour Factor	92	92	92	92	92	92	92	92	92	92	92	92
Heavy Vehicles, %	2	2	2	2	2	2	2	2	2	2	2	2
Mvmt Flow	7	4	0	8	0	5	1	610	8	7	628	18

Major/Minor	Minor2		Minor1		Major1			Major2				
Conflicting Flow All	958	1271	323	946	1276	309	646	0	0	618	0	0
Stage 1	651	651	-	616	616	-	-	-	-	-	-	-
Stage 2	307	620	-	330	660	-	-	-	-	-	-	-
Critical Hdwy	7.54	6.54	6.94	7.54	6.54	6.94	4.14	-	-	4.14	-	-
Critical Hdwy Stg 1	6.54	5.54	-	6.54	5.54	-	-	-	-	-	-	-
Critical Hdwy Stg 2	6.54	5.54	-	6.54	5.54	-	-	-	-	-	-	-
Follow-up Hdwy	3.52	4.02	3.32	3.52	4.02	3.32	2.22	-	-	2.22	-	-
Pot Cap-1 Maneuver	212	167	673	216	165	687	935	-	-	958	-	-
Stage 1	424	463	-	445	480	-	-	-	-	-	-	-
Stage 2	678	478	-	657	458	-	-	-	-	-	-	-
Platoon blocked, %								-	-	-	-	-
Mov Cap-1 Maneuver	209	166	673	212	164	687	935	-	-	958	-	-
Mov Cap-2 Maneuver	324	288	-	332	288	-	-	-	-	-	-	-
Stage 1	424	460	-	445	480	-	-	-	-	-	-	-
Stage 2	672	478	-	646	455	-	-	-	-	-	-	-

Approach	EB		WB		NB		SB	
HCM Control Delay, s	17.1		13.8		0		0.1	
HCM LOS	C		B					

Minor Lane/Major Mvmt	NBL	NBT	NBR	EBLn1	WBLn1	SBL	SBT	SBR
Capacity (veh/h)	935	-	-	309	423	958	-	-
HCM Lane V/C Ratio	0.001	-	-	0.035	0.031	0.007	-	-
HCM Control Delay (s)	8.9	-	-	17.1	13.8	8.8	-	-
HCM Lane LOS	A	-	-	C	B	A	-	-
HCM 95th %tile Q(veh)	0	-	-	0.1	0.1	0	-	-

Intersection						
Int Delay, s/veh	0.7					
Movement	WBL	WBR	NBT	NBR	SBL	SBT
Lane Configurations	↔		↑↓		↔	↑↑
Traffic Vol, veh/h	20	10	562	30	30	542
Future Vol, veh/h	20	10	562	30	30	542
Conflicting Peds, #/hr	0	0	0	0	0	0
Sign Control	Stop	Stop	Free	Free	Free	Free
RT Channelized	-	None	-	None	-	None
Storage Length	0	-	-	-	140	-
Veh in Median Storage, #	0	-	0	-	-	0
Grade, %	0	-	0	-	-	0
Peak Hour Factor	91	91	91	91	91	91
Heavy Vehicles, %	2	2	2	2	2	2
Mvmt Flow	22	11	618	33	33	596

Major/Minor	Minor1	Major1	Major2			
Conflicting Flow All	999	326	0	0	651	0
Stage 1	635	-	-	-	-	-
Stage 2	364	-	-	-	-	-
Critical Hdwy	6.84	6.94	-	-	4.14	-
Critical Hdwy Stg 1	5.84	-	-	-	-	-
Critical Hdwy Stg 2	5.84	-	-	-	-	-
Follow-up Hdwy	3.52	3.32	-	-	2.22	-
Pot Cap-1 Maneuver	240	670	-	-	931	-
Stage 1	490	-	-	-	-	-
Stage 2	673	-	-	-	-	-
Platoon blocked, %			-	-		
Mov Cap-1 Maneuver	232	670	-	-	931	-
Mov Cap-2 Maneuver	232	-	-	-	-	-
Stage 1	490	-	-	-	-	-
Stage 2	649	-	-	-	-	-

Approach	WB	NB	SB
HCM Control Delay, s	18.6	0	0.5
HCM LOS	C		

Minor Lane/Major Mvmt	NBT	NBRWBLn1	SBL	SBT
Capacity (veh/h)	-	-	297	931
HCM Lane V/C Ratio	-	-	0.111	0.035
HCM Control Delay (s)	-	-	18.6	9
HCM Lane LOS	-	-	C	A
HCM 95th %tile Q(veh)	-	-	0.4	0.1

Heritage at Dalia Ranch
4: Imperial Ave & Neckel Rd

Opening Year 2023
Timing Plan: PM PEAK

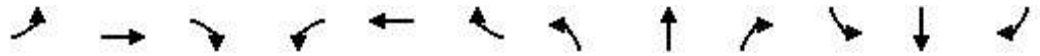

Movement	EBL	EBT	EBR	WBL	WBT	WBR	NBL	NBT	NBR	SBL	SBT	SBR
Lane Configurations		↕			↕		↕	↕		↕	↕	
Traffic Volume (veh/h)	12	26	4	82	20	46	11	555	83	29	496	28
Future Volume (veh/h)	12	26	4	82	20	46	11	555	83	29	496	28
Initial Q (Qb), veh	0	0	0	0	0	0	0	0	0	0	0	0
Ped-Bike Adj(A_pbT)	1.00		1.00	1.00		1.00	1.00		1.00	1.00		1.00
Parking Bus, Adj	1.00	1.00	1.00	1.00	1.00	1.00	1.00	1.00	1.00	1.00	1.00	1.00
Work Zone On Approach		No			No			No			No	
Adj Sat Flow, veh/h/ln	1870	1870	1870	1870	1870	1870	1870	1870	1870	1870	1870	1870
Adj Flow Rate, veh/h	13	28	4	89	22	50	12	603	90	32	539	30
Peak Hour Factor	0.92	0.92	0.92	0.92	0.92	0.92	0.92	0.92	0.92	0.92	0.92	0.92
Percent Heavy Veh, %	2	2	2	2	2	2	2	2	2	2	2	2
Cap, veh/h	26	55	8	123	31	69	28	916	136	66	1085	60
Arrive On Green	0.05	0.05	0.05	0.13	0.13	0.13	0.02	0.30	0.30	0.04	0.32	0.32
Sat Flow, veh/h	524	1129	161	954	236	536	1781	3102	462	1781	3423	190
Grp Volume(v), veh/h	45	0	0	161	0	0	12	345	348	32	279	290
Grp Sat Flow(s),veh/h/ln	1815	0	0	1726	0	0	1781	1777	1787	1781	1777	1836
Q Serve(g_s), s	1.0	0.0	0.0	3.7	0.0	0.0	0.3	6.9	7.0	0.7	5.2	5.2
Cycle Q Clear(g_c), s	1.0	0.0	0.0	3.7	0.0	0.0	0.3	6.9	7.0	0.7	5.2	5.2
Prop In Lane	0.29		0.09	0.55		0.31	1.00		0.26	1.00		0.10
Lane Grp Cap(c), veh/h	89	0	0	223	0	0	28	525	528	66	563	582
V/C Ratio(X)	0.51	0.00	0.00	0.72	0.00	0.00	0.43	0.66	0.66	0.48	0.50	0.50
Avail Cap(c_a), veh/h	799	0	0	760	0	0	218	826	830	218	826	853
HCM Platoon Ratio	1.00	1.00	1.00	1.00	1.00	1.00	1.00	1.00	1.00	1.00	1.00	1.00
Upstream Filter(l)	1.00	0.00	0.00	1.00	0.00	0.00	1.00	1.00	1.00	1.00	1.00	1.00
Uniform Delay (d), s/veh	19.0	0.0	0.0	17.1	0.0	0.0	19.9	12.6	12.6	19.3	11.3	11.3
Incr Delay (d2), s/veh	4.4	0.0	0.0	4.3	0.0	0.0	10.3	1.4	1.4	5.3	0.7	0.7
Initial Q Delay(d3),s/veh	0.0	0.0	0.0	0.0	0.0	0.0	0.0	0.0	0.0	0.0	0.0	0.0
%ile BackOfQ(50%),veh/ln	0.5	0.0	0.0	1.5	0.0	0.0	0.2	2.4	2.4	0.4	1.7	1.8
Unsig. Movement Delay, s/veh												
LnGrp Delay(d),s/veh	23.4	0.0	0.0	21.4	0.0	0.0	30.2	14.0	14.0	24.6	12.0	12.0
LnGrp LOS	C	A	A	C	A	A	C	B	B	C	B	B
Approach Vol, veh/h		45			161			705			601	
Approach Delay, s/veh		23.4			21.4			14.3			12.7	
Approach LOS		C			C			B			B	
Timer - Assigned Phs	1	2		4	5	6		8				
Phs Duration (G+Y+Rc), s	6.5	17.1		7.0	5.6	18.0		10.3				
Change Period (Y+Rc), s	5.0	5.0		5.0	5.0	5.0		5.0				
Max Green Setting (Gmax), s	5.0	19.0		18.0	5.0	19.0		18.0				
Max Q Clear Time (g_c+I1), s	2.7	9.0		3.0	2.3	7.2		5.7				
Green Ext Time (p_c), s	0.0	3.1		0.1	0.0	2.7		0.6				

Intersection Summary

HCM 6th Ctrl Delay	14.7
HCM 6th LOS	B

Intersection												
Int Delay, s/veh	7.7											
Movement	EBL	EBT	EBR	WBL	WBT	WBR	NBL	NBT	NBR	SBL	SBT	SBR
Lane Configurations		↕			↕			↕			↕	
Traffic Vol, veh/h	2	38	8	23	44	1	5	6	10	0	5	7
Future Vol, veh/h	2	38	8	23	44	1	5	6	10	0	5	7
Conflicting Peds, #/hr	0	0	0	0	0	0	0	0	0	0	0	0
Sign Control	Stop	Stop	Stop	Stop	Stop	Stop	Free	Free	Free	Free	Free	Free
RT Channelized	-	-	None	-	-	None	-	-	None	-	-	None
Storage Length	-	-	-	-	-	-	-	-	-	-	-	-
Veh in Median Storage, #	-	0	-	-	0	-	-	0	-	-	0	-
Grade, %	-	0	-	-	0	-	-	0	-	-	0	-
Peak Hour Factor	79	79	79	79	79	79	79	79	79	79	79	79
Heavy Vehicles, %	2	2	2	2	2	2	2	2	2	2	2	2
Mvmt Flow	3	48	10	29	56	1	6	8	13	0	6	9

Major/Minor	Minor2		Minor1		Major1			Major2				
Conflicting Flow All	66	44	11	67	42	15	15	0	0	21	0	0
Stage 1	11	11	-	27	27	-	-	-	-	-	-	-
Stage 2	55	33	-	40	15	-	-	-	-	-	-	-
Critical Hdwy	7.12	6.52	6.22	7.12	6.52	6.22	4.12	-	-	4.12	-	-
Critical Hdwy Stg 1	6.12	5.52	-	6.12	5.52	-	-	-	-	-	-	-
Critical Hdwy Stg 2	6.12	5.52	-	6.12	5.52	-	-	-	-	-	-	-
Follow-up Hdwy	3.518	4.018	3.318	3.518	4.018	3.318	2.218	-	-	2.218	-	-
Pot Cap-1 Maneuver	927	848	1070	926	850	1065	1603	-	-	1595	-	-
Stage 1	1010	886	-	990	873	-	-	-	-	-	-	-
Stage 2	957	868	-	975	883	-	-	-	-	-	-	-
Platoon blocked, %								-	-	-	-	-
Mov Cap-1 Maneuver	877	845	1070	875	847	1065	1603	-	-	1595	-	-
Mov Cap-2 Maneuver	877	845	-	875	847	-	-	-	-	-	-	-
Stage 1	1006	886	-	986	870	-	-	-	-	-	-	-
Stage 2	891	865	-	913	883	-	-	-	-	-	-	-

Approach	EB		WB		NB		SB	
HCM Control Delay, s	9.4		9.7		1.7		0	
HCM LOS	A		A					

Minor Lane/Major Mvmt	NBL	NBT	NBR	EBLn1	WBLn1	SBL	SBT	SBR
Capacity (veh/h)	1603	-	-	877	859	1595	-	-
HCM Lane V/C Ratio	0.004	-	-	0.069	0.1	-	-	-
HCM Control Delay (s)	7.3	0	-	9.4	9.7	0	-	-
HCM Lane LOS	A	A	-	A	A	A	-	-
HCM 95th %tile Q(veh)	0	-	-	0.2	0.3	0	-	-

Heritage at Dalia Ranch
6: Imperial Ave & Worthington Rd/Barioni Blvd

Opening Year 2023
Timing Plan: PM PEAK

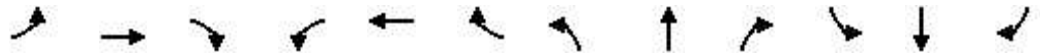

Movement	EBL	EBT	EBR	WBL	WBT	WBR	NBL	NBT	NBR	SBL	SBT	SBR
Lane Configurations		↖	↗		↖	↗	↖	↗		↖	↗	
Traffic Volume (veh/h)	48	74	105	54	112	51	112	666	14	27	593	63
Future Volume (veh/h)	48	74	105	54	112	51	112	666	14	27	593	63
Initial Q (Qb), veh	0	0	0	0	0	0	0	0	0	0	0	0
Ped-Bike Adj(A_pbT)	1.00		1.00	1.00		1.00	1.00		1.00	1.00		1.00
Parking Bus, Adj	1.00	1.00	1.00	1.00	1.00	1.00	1.00	1.00	1.00	1.00	1.00	1.00
Work Zone On Approach		No			No			No			No	
Adj Sat Flow, veh/h/ln	1870	1870	1870	1870	1870	1870	1870	1870	1870	1870	1870	1870
Adj Flow Rate, veh/h	53	81	115	59	123	56	123	732	15	30	652	69
Peak Hour Factor	0.91	0.91	0.91	0.91	0.91	0.91	0.91	0.91	0.91	0.91	0.91	0.91
Percent Heavy Veh, %	2	2	2	2	2	2	2	2	2	2	2	2
Cap, veh/h	87	133	191	86	179	227	157	1147	24	60	868	92
Arrive On Green	0.12	0.12	0.12	0.14	0.14	0.14	0.09	0.32	0.32	0.03	0.27	0.27
Sat Flow, veh/h	725	1109	1585	597	1244	1585	1781	3561	73	1781	3243	343
Grp Volume(v), veh/h	134	0	115	182	0	56	123	365	382	30	357	364
Grp Sat Flow(s),veh/h/ln	1834	0	1585	1841	0	1585	1781	1777	1857	1781	1777	1809
Q Serve(g_s), s	3.6	0.0	3.6	4.9	0.0	1.6	3.6	9.2	9.2	0.9	9.7	9.7
Cycle Q Clear(g_c), s	3.6	0.0	3.6	4.9	0.0	1.6	3.6	9.2	9.2	0.9	9.7	9.7
Prop In Lane	0.40		1.00	0.32		1.00	1.00		0.04	1.00		0.19
Lane Grp Cap(c), veh/h	220	0	191	264	0	227	157	572	598	60	475	484
V/C Ratio(X)	0.61	0.00	0.60	0.69	0.00	0.25	0.78	0.64	0.64	0.50	0.75	0.75
Avail Cap(c_a), veh/h	628	0	543	630	0	543	203	642	671	169	608	619
HCM Platoon Ratio	1.00	1.00	1.00	1.00	1.00	1.00	1.00	1.00	1.00	1.00	1.00	1.00
Upstream Filter(I)	1.00	0.00	1.00	1.00	0.00	1.00	1.00	1.00	1.00	1.00	1.00	1.00
Uniform Delay (d), s/veh	22.0	0.0	21.9	21.4	0.0	20.0	23.5	15.2	15.2	25.0	17.6	17.7
Incr Delay (d2), s/veh	2.7	0.0	3.1	3.2	0.0	0.6	13.7	1.8	1.7	6.3	3.9	3.9
Initial Q Delay(d3),s/veh	0.0	0.0	0.0	0.0	0.0	0.0	0.0	0.0	0.0	0.0	0.0	0.0
%ile BackOfQ(50%),veh/ln	1.6	0.0	1.4	2.2	0.0	0.6	2.0	3.5	3.7	0.4	4.0	4.1
Unsig. Movement Delay, s/veh												
LnGrp Delay(d),s/veh	24.6	0.0	25.0	24.6	0.0	20.5	37.2	17.0	16.9	31.2	21.5	21.5
LnGrp LOS	C	A	C	C	A	C	D	B	B	C	C	C
Approach Vol, veh/h		249			238			870			751	
Approach Delay, s/veh		24.8			23.6			19.8			21.9	
Approach LOS		C			C			B			C	
Timer - Assigned Phs	1	2		4	5	6		8				
Phs Duration (G+Y+Rc), s	6.8	21.9		11.3	9.6	19.1		12.5				
Change Period (Y+Rc), s	5.0	5.0		5.0	5.0	5.0		5.0				
Max Green Setting (Gmax), s	5.0	19.0		18.0	6.0	18.0		18.0				
Max Q Clear Time (g_c+I1), s	2.9	11.2		5.6	5.6	11.7		6.9				
Green Ext Time (p_c), s	0.0	2.8		0.8	0.0	2.4		0.8				
Intersection Summary												
HCM 6th Ctrl Delay			21.6									
HCM 6th LOS			C									

Intersection

Intersection Delay, s/veh 10.5

Intersection LOS B

Movement	EBL	EBT	EBR	WBL	WBT	WBR	NBL	NBT	NBR	SBL	SBT	SBR
Lane Configurations		↔	↔		↔	↔		↔			↔	
Traffic Vol, veh/h	26	187	33	27	215	34	1	0	0	37	5	24
Future Vol, veh/h	26	187	33	27	215	34	1	0	0	37	5	24
Peak Hour Factor	0.80	0.80	0.80	0.80	0.80	0.80	0.80	0.80	0.80	0.80	0.80	0.80
Heavy Vehicles, %	2	2	2	2	2	2	2	2	2	2	2	2
Mvmt Flow	33	234	41	34	269	43	1	0	0	46	6	30
Number of Lanes	0	1	1	0	1	1	0	1	0	0	1	0

Approach	EB	WB	NB	SB
Opposing Approach	WB	EB	SB	NB
Opposing Lanes	2	2	1	1
Conflicting Approach Left	SB	NB	EB	WB
Conflicting Lanes Left	1	1	2	2
Conflicting Approach Right	NB	SB	WB	EB
Conflicting Lanes Right	1	1	2	2
HCM Control Delay	10.4	11	8.9	9.1
HCM LOS	B	B	A	A

Lane	NBLn1	EBLn1	EBLn2	WBLn1	WBLn2	SBLn1
Vol Left, %	100%	12%	0%	11%	0%	56%
Vol Thru, %	0%	88%	0%	89%	0%	8%
Vol Right, %	0%	0%	100%	0%	100%	36%
Sign Control	Stop	Stop	Stop	Stop	Stop	Stop
Traffic Vol by Lane	1	213	33	242	34	66
LT Vol	1	26	0	27	0	37
Through Vol	0	187	0	215	0	5
RT Vol	0	0	33	0	34	24
Lane Flow Rate	1	266	41	302	42	82
Geometry Grp	2	7	7	7	7	2
Degree of Util (X)	0.002	0.378	0.05	0.426	0.051	0.122
Departure Headway (Hd)	5.78	5.11	4.345	5.073	4.314	5.32
Convergence, Y/N	Yes	Yes	Yes	Yes	Yes	Yes
Cap	616	703	823	708	828	672
Service Time	3.847	2.846	2.08	2.809	2.049	3.368
HCM Lane V/C Ratio	0.002	0.378	0.05	0.427	0.051	0.122
HCM Control Delay	8.9	10.9	7.3	11.5	7.3	9.1
HCM Lane LOS	A	B	A	B	A	A
HCM 95th-tile Q	0	1.8	0.2	2.1	0.2	0.4

Heritage at Dalia Ranch
8: Imperial Ave & Aten Rd

Opening Year 2023
Timing Plan: PM PEAK



Movement	EBL	EBT	EBR	WBL	WBT	WBR	NBL	NBT	NBR	SBL	SBT	SBR
Lane Configurations												
Traffic Volume (veh/h)	189	276	68	178	288	122	78	664	149	112	538	209
Future Volume (veh/h)	189	276	68	178	288	122	78	664	149	112	538	209
Initial Q (Qb), veh	0	0	0	0	0	0	0	0	0	0	0	0
Ped-Bike Adj(A_pbT)	1.00		1.00	1.00		1.00	1.00		1.00	1.00		1.00
Parking Bus, Adj	1.00	1.00	1.00	1.00	1.00	1.00	1.00	1.00	1.00	1.00	1.00	1.00
Work Zone On Approach		No			No			No			No	
Adj Sat Flow, veh/h/ln	1870	1870	1870	1870	1870	1870	1870	1870	1870	1870	1870	1870
Adj Flow Rate, veh/h	201	294	72	189	306	130	83	706	159	119	572	222
Peak Hour Factor	0.94	0.94	0.94	0.94	0.94	0.94	0.94	0.94	0.94	0.94	0.94	0.94
Percent Heavy Veh, %	2	2	2	2	2	2	2	2	2	2	2	2
Cap, veh/h	249	536	129	236	445	185	111	927	413	152	1010	450
Arrive On Green	0.14	0.19	0.19	0.13	0.18	0.18	0.06	0.26	0.26	0.09	0.28	0.28
Sat Flow, veh/h	1781	2840	684	1781	2447	1017	1781	3554	1585	1781	3554	1585
Grp Volume(v), veh/h	201	182	184	189	220	216	83	706	159	119	572	222
Grp Sat Flow(s),veh/h/ln	1781	1777	1747	1781	1777	1687	1781	1777	1585	1781	1777	1585
Q Serve(g_s), s	6.6	5.6	5.7	6.2	7.0	7.2	2.8	11.0	5.0	3.9	8.3	7.0
Cycle Q Clear(g_c), s	6.6	5.6	5.7	6.2	7.0	7.2	2.8	11.0	5.0	3.9	8.3	7.0
Prop In Lane	1.00		0.39	1.00		0.60	1.00		1.00	1.00		1.00
Lane Grp Cap(c), veh/h	249	336	330	236	323	307	111	927	413	152	1010	450
V/C Ratio(X)	0.81	0.54	0.56	0.80	0.68	0.70	0.75	0.76	0.38	0.78	0.57	0.49
Avail Cap(c_a), veh/h	325	531	522	325	531	504	177	1121	500	207	1180	526
HCM Platoon Ratio	1.00	1.00	1.00	1.00	1.00	1.00	1.00	1.00	1.00	1.00	1.00	1.00
Upstream Filter(I)	1.00	1.00	1.00	1.00	1.00	1.00	1.00	1.00	1.00	1.00	1.00	1.00
Uniform Delay (d), s/veh	25.1	22.1	22.1	25.3	23.0	23.1	27.8	20.5	18.3	27.0	18.4	17.9
Incr Delay (d2), s/veh	10.8	1.4	1.5	9.5	2.5	2.9	9.6	2.5	0.6	12.4	0.5	0.8
Initial Q Delay(d3),s/veh	0.0	0.0	0.0	0.0	0.0	0.0	0.0	0.0	0.0	0.0	0.0	0.0
%ile BackOfQ(50%),veh/ln	3.4	2.3	2.3	3.1	2.9	2.9	1.4	4.5	1.7	2.1	3.2	2.4
Unsig. Movement Delay, s/veh												
LnGrp Delay(d),s/veh	35.9	23.4	23.6	34.8	25.6	26.1	37.4	23.1	18.9	39.4	18.9	18.8
LnGrp LOS	D	C	C	C	C	C	D	C	B	D	B	B
Approach Vol, veh/h		567			625			948			913	
Approach Delay, s/veh		27.9			28.5			23.6			21.5	
Approach LOS		C			C			C			C	
Timer - Assigned Phs	1	2	3	4	5	6	7	8				
Phs Duration (G+Y+Rc), s	20.2	20.7	13.0	16.4	8.8	22.1	13.4	15.9				
Change Period (Y+Rc), s	5.0	5.0	5.0	5.0	5.0	5.0	5.0	5.0				
Max Green Setting (Gmax), s	19.0	19.0	11.0	18.0	6.0	20.0	11.0	18.0				
Max Q Clear Time (g_c+1/3g), s	13.0	13.0	8.2	7.7	4.8	10.3	8.6	9.2				
Green Ext Time (p_c), s	0.0	2.7	0.1	1.5	0.0	3.3	0.1	1.7				
Intersection Summary												
HCM 6th Ctrl Delay											24.8	
HCM 6th LOS											C	

Heritage at Dalia Ranch
1: SR-86 & Keystone Rd

Opening Year 2023 + P1 Proj
Timing Plan: AM PEAK

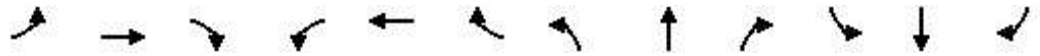

Movement	EBL	EBT	EBR	WBL	WBT	WBR	NBL	NBT	NBR	SBL	SBT	SBR
Lane Configurations		↕			↕		↕	↕↕	↕	↕	↕↕	↕
Traffic Volume (veh/h)	33	33	11	19	24	42	19	454	49	45	517	37
Future Volume (veh/h)	33	33	11	19	24	42	19	454	49	45	517	37
Initial Q (Qb), veh	0	0	0	0	0	0	0	0	0	0	0	0
Ped-Bike Adj(A_pbT)	1.00		1.00	1.00		1.00	1.00		1.00	1.00		1.00
Parking Bus, Adj	1.00	1.00	1.00	1.00	1.00	1.00	1.00	1.00	1.00	1.00	1.00	1.00
Work Zone On Approach		No			No			No			No	
Adj Sat Flow, veh/h/ln	1870	1870	1870	1870	1870	1870	1870	1870	1870	1870	1870	1870
Adj Flow Rate, veh/h	37	37	12	21	27	47	21	504	54	50	574	41
Peak Hour Factor	0.90	0.90	0.90	0.90	0.90	0.90	0.90	0.90	0.90	0.90	0.90	0.90
Percent Heavy Veh, %	2	2	2	2	2	2	2	2	2	2	2	2
Cap, veh/h	259	110	31	190	74	108	48	1021	455	102	1129	503
Arrive On Green	0.13	0.13	0.13	0.13	0.13	0.13	0.03	0.29	0.29	0.06	0.32	0.32
Sat Flow, veh/h	598	830	232	276	556	814	1781	3554	1585	1781	3554	1585
Grp Volume(v), veh/h	86	0	0	95	0	0	21	504	54	50	574	41
Grp Sat Flow(s),veh/h/ln	1659	0	0	1646	0	0	1781	1777	1585	1781	1777	1585
Q Serve(g_s), s	0.0	0.0	0.0	0.2	0.0	0.0	0.3	3.4	0.7	0.8	3.8	0.5
Cycle Q Clear(g_c), s	1.2	0.0	0.0	1.4	0.0	0.0	0.3	3.4	0.7	0.8	3.8	0.5
Prop In Lane	0.43		0.14	0.22		0.49	1.00		1.00	1.00		1.00
Lane Grp Cap(c), veh/h	400	0	0	372	0	0	48	1021	455	102	1129	503
V/C Ratio(X)	0.21	0.00	0.00	0.26	0.00	0.00	0.44	0.49	0.12	0.49	0.51	0.08
Avail Cap(c_a), veh/h	1169	0	0	1160	0	0	310	2228	994	310	2228	994
HCM Platoon Ratio	1.00	1.00	1.00	1.00	1.00	1.00	1.00	1.00	1.00	1.00	1.00	1.00
Upstream Filter(l)	1.00	0.00	0.00	1.00	0.00	0.00	1.00	1.00	1.00	1.00	1.00	1.00
Uniform Delay (d), s/veh	11.3	0.0	0.0	11.4	0.0	0.0	13.8	8.5	7.6	13.1	8.0	6.9
Incr Delay (d2), s/veh	0.3	0.0	0.0	0.4	0.0	0.0	6.2	0.4	0.1	3.6	0.4	0.1
Initial Q Delay(d3),s/veh	0.0	0.0	0.0	0.0	0.0	0.0	0.0	0.0	0.0	0.0	0.0	0.0
%ile BackOfQ(50%),veh/ln	0.4	0.0	0.0	0.4	0.0	0.0	0.2	0.9	0.2	0.3	0.9	0.1
Unsig. Movement Delay, s/veh												
LnGrp Delay(d),s/veh	11.6	0.0	0.0	11.8	0.0	0.0	20.0	8.9	7.7	16.7	8.3	6.9
LnGrp LOS	B	A	A	B	A	A	B	A	A	B	A	A
Approach Vol, veh/h		86			95			579			665	
Approach Delay, s/veh		11.6			11.8			9.2			8.9	
Approach LOS		B			B			A			A	
Timer - Assigned Phs	1	2		4	5	6		8				
Phs Duration (G+Y+Rc), s	6.6	13.2		8.8	5.8	14.1		8.8				
Change Period (Y+Rc), s	5.0	5.0		5.0	5.0	5.0		5.0				
Max Green Setting (Gmax), s	5.0	18.0		18.0	5.0	18.0		18.0				
Max Q Clear Time (g_c+I1), s	2.8	5.4		3.2	2.3	5.8		3.4				
Green Ext Time (p_c), s	0.0	2.9		0.3	0.0	3.2		0.4				
Intersection Summary												
HCM 6th Ctrl Delay				9.3								
HCM 6th LOS				A								

Intersection												
Int Delay, s/veh	0.4											
Movement	EBL	EBT	EBR	WBL	WBT	WBR	NBL	NBT	NBR	SBL	SBT	SBR
Lane Configurations		↕			↕		↕	↕		↕	↕	
Traffic Vol, veh/h	20	3	2	1	2	5	0	521	1	1	522	7
Future Vol, veh/h	20	3	2	1	2	5	0	521	1	1	522	7
Conflicting Peds, #/hr	0	0	0	0	0	0	0	0	0	0	0	0
Sign Control	Stop	Stop	Stop	Stop	Stop	Stop	Free	Free	Free	Free	Free	Free
RT Channelized	-	-	None	-	-	None	-	-	None	-	-	None
Storage Length	-	-	-	-	-	-	50	-	-	50	-	-
Veh in Median Storage, #	-	1	-	-	1	-	-	0	-	-	0	-
Grade, %	-	0	-	-	0	-	-	0	-	-	0	-
Peak Hour Factor	94	94	94	94	94	94	94	94	94	94	94	94
Heavy Vehicles, %	2	2	2	2	2	2	2	2	2	2	2	2
Mvmt Flow	21	3	2	1	2	5	0	554	1	1	555	7

Major/Minor	Minor2		Minor1		Major1			Major2				
Conflicting Flow All	839	1116	281	836	1119	278	562	0	0	555	0	0
Stage 1	561	561	-	555	555	-	-	-	-	-	-	-
Stage 2	278	555	-	281	564	-	-	-	-	-	-	-
Critical Hdwy	7.54	6.54	6.94	7.54	6.54	6.94	4.14	-	-	4.14	-	-
Critical Hdwy Stg 1	6.54	5.54	-	6.54	5.54	-	-	-	-	-	-	-
Critical Hdwy Stg 2	6.54	5.54	-	6.54	5.54	-	-	-	-	-	-	-
Follow-up Hdwy	3.52	4.02	3.32	3.52	4.02	3.32	2.22	-	-	2.22	-	-
Pot Cap-1 Maneuver	259	206	716	260	205	719	1005	-	-	1011	-	-
Stage 1	480	508	-	484	511	-	-	-	-	-	-	-
Stage 2	705	511	-	702	507	-	-	-	-	-	-	-
Platoon blocked, %								-	-	-	-	-
Mov Cap-1 Maneuver	256	206	716	257	205	719	1005	-	-	1011	-	-
Mov Cap-2 Maneuver	369	326	-	371	326	-	-	-	-	-	-	-
Stage 1	480	507	-	484	511	-	-	-	-	-	-	-
Stage 2	697	511	-	695	506	-	-	-	-	-	-	-

Approach	EB		WB		NB		SB	
HCM Control Delay, s	15.2		12.2		0		0	
HCM LOS	C		B					

Minor Lane/Major Mvmt	NBL	NBT	NBR	EBLn1	WBLn1	SBL	SBT	SBR
Capacity (veh/h)	1005	-	-	378	507	1011	-	-
HCM Lane V/C Ratio	-	-	-	0.07	0.017	0.001	-	-
HCM Control Delay (s)	0	-	-	15.2	12.2	8.6	-	-
HCM Lane LOS	A	-	-	C	B	A	-	-
HCM 95th %tile Q(veh)	0	-	-	0.2	0.1	0	-	-

Intersection						
Int Delay, s/veh	1.6					
Movement	WBL	WBR	NBT	NBR	SBL	SBT
Lane Configurations	↔		↑↓		↔	↑↑
Traffic Vol, veh/h	59	23	499	41	20	505
Future Vol, veh/h	59	23	499	41	20	505
Conflicting Peds, #/hr	0	0	0	0	0	0
Sign Control	Stop	Stop	Free	Free	Free	Free
RT Channelized	-	None	-	None	-	None
Storage Length	0	-	-	-	140	-
Veh in Median Storage, #	0	-	0	-	-	0
Grade, %	0	-	0	-	-	0
Peak Hour Factor	91	91	91	91	91	91
Heavy Vehicles, %	2	2	2	2	2	2
Mvmt Flow	65	25	548	45	22	555

Major/Minor	Minor1	Major1	Major2		
Conflicting Flow All	893	297	0	0	593
Stage 1	571	-	-	-	-
Stage 2	322	-	-	-	-
Critical Hdwy	6.84	6.94	-	-	4.14
Critical Hdwy Stg 1	5.84	-	-	-	-
Critical Hdwy Stg 2	5.84	-	-	-	-
Follow-up Hdwy	3.52	3.32	-	-	2.22
Pot Cap-1 Maneuver	281	699	-	-	979
Stage 1	529	-	-	-	-
Stage 2	707	-	-	-	-
Platoon blocked, %			-	-	-
Mov Cap-1 Maneuver	275	699	-	-	979
Mov Cap-2 Maneuver	275	-	-	-	-
Stage 1	529	-	-	-	-
Stage 2	691	-	-	-	-

Approach	WB	NB	SB
HCM Control Delay, s	19.9	0	0.3
HCM LOS	C		

Minor Lane/Major Mvmt	NBT	NBRWBLn1	SBL	SBT
Capacity (veh/h)	-	-	331	979
HCM Lane V/C Ratio	-	-	0.272	0.022
HCM Control Delay (s)	-	-	19.9	8.8
HCM Lane LOS	-	-	C	A
HCM 95th %tile Q(veh)	-	-	1.1	0.1

Heritage at Dalia Ranch
4: Imperial Ave & Neckel Rd

Opening Year 2023 + P1 Proj
Timing Plan: AM PEAK

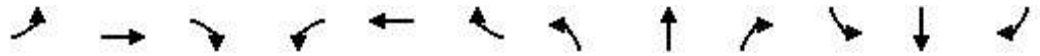

Movement	EBL	EBT	EBR	WBL	WBT	WBR	NBL	NBT	NBR	SBL	SBT	SBR
Lane Configurations		↕			↕		↕	↕↔		↕	↕↔	
Traffic Volume (veh/h)	49	43	64	142	64	56	26	442	65	14	511	36
Future Volume (veh/h)	49	43	64	142	64	56	26	442	65	14	511	36
Initial Q (Qb), veh	0	0	0	0	0	0	0	0	0	0	0	0
Ped-Bike Adj(A_pbT)	1.00		1.00	1.00		1.00	1.00		1.00	1.00		1.00
Parking Bus, Adj	1.00	1.00	1.00	1.00	1.00	1.00	1.00	1.00	1.00	1.00	1.00	1.00
Work Zone On Approach		No			No			No			No	
Adj Sat Flow, veh/h/ln	1870	1870	1870	1870	1870	1870	1870	1870	1870	1870	1870	1870
Adj Flow Rate, veh/h	54	47	70	156	70	62	29	486	71	15	562	40
Peak Hour Factor	0.91	0.91	0.91	0.91	0.91	0.91	0.91	0.91	0.91	0.91	0.91	0.91
Percent Heavy Veh, %	2	2	2	2	2	2	2	2	2	2	2	2
Cap, veh/h	73	63	94	199	89	79	59	788	115	33	804	57
Arrive On Green	0.13	0.13	0.13	0.21	0.21	0.21	0.03	0.25	0.25	0.02	0.24	0.24
Sat Flow, veh/h	542	472	703	951	427	378	1781	3113	453	1781	3365	239
Grp Volume(v), veh/h	171	0	0	288	0	0	29	276	281	15	296	306
Grp Sat Flow(s),veh/h/ln	1717	0	0	1755	0	0	1781	1777	1789	1781	1777	1827
Q Serve(g_s), s	5.0	0.0	0.0	8.1	0.0	0.0	0.8	7.2	7.2	0.4	7.9	8.0
Cycle Q Clear(g_c), s	5.0	0.0	0.0	8.1	0.0	0.0	0.8	7.2	7.2	0.4	7.9	8.0
Prop In Lane	0.32		0.41	0.54		0.22	1.00		0.25	1.00		0.13
Lane Grp Cap(c), veh/h	231	0	0	368	0	0	59	450	453	33	424	436
V/C Ratio(X)	0.74	0.00	0.00	0.78	0.00	0.00	0.49	0.61	0.62	0.45	0.70	0.70
Avail Cap(c_a), veh/h	593	0	0	607	0	0	171	648	653	171	648	667
HCM Platoon Ratio	1.00	1.00	1.00	1.00	1.00	1.00	1.00	1.00	1.00	1.00	1.00	1.00
Upstream Filter(l)	1.00	0.00	0.00	1.00	0.00	0.00	1.00	1.00	1.00	1.00	1.00	1.00
Uniform Delay (d), s/veh	21.7	0.0	0.0	19.4	0.0	0.0	24.8	17.2	17.2	25.3	18.1	18.1
Incr Delay (d2), s/veh	4.7	0.0	0.0	3.7	0.0	0.0	6.3	1.4	1.4	9.2	2.1	2.1
Initial Q Delay(d3),s/veh	0.0	0.0	0.0	0.0	0.0	0.0	0.0	0.0	0.0	0.0	0.0	0.0
%ile BackOfQ(50%),veh/ln	2.1	0.0	0.0	3.3	0.0	0.0	0.4	2.8	2.8	0.3	3.1	3.2
Unsig. Movement Delay, s/veh												
LnGrp Delay(d),s/veh	26.3	0.0	0.0	23.1	0.0	0.0	31.1	18.6	18.6	34.5	20.2	20.2
LnGrp LOS	C	A	A	C	A	A	C	B	B	C	C	C
Approach Vol, veh/h		171			288			586				617
Approach Delay, s/veh		26.3			23.1			19.2				20.5
Approach LOS		C			C			B				C
Timer - Assigned Phs	1	2		4	5	6		8				
Phs Duration (G+Y+Rc), s	6.0	18.2		12.0	6.7	17.4		15.9				
Change Period (Y+Rc), s	5.0	5.0		5.0	5.0	5.0		5.0				
Max Green Setting (Gmax), s	5.0	19.0		18.0	5.0	19.0		18.0				
Max Q Clear Time (g_c+I1), s	2.4	9.2		7.0	2.8	10.0		10.1				
Green Ext Time (p_c), s	0.0	2.4		0.6	0.0	2.5		1.0				
Intersection Summary												
HCM 6th Ctrl Delay				21.1								
HCM 6th LOS				C								

Intersection												
Int Delay, s/veh	7.7											
Movement	EBL	EBT	EBR	WBL	WBT	WBR	NBL	NBT	NBR	SBL	SBT	SBR
Lane Configurations		↕			↕			↕			↕	
Traffic Vol, veh/h	4	41	23	67	44	0	7	6	45	1	2	1
Future Vol, veh/h	4	41	23	67	44	0	7	6	45	1	2	1
Conflicting Peds, #/hr	0	0	0	0	0	0	0	0	0	0	0	0
Sign Control	Stop	Stop	Stop	Stop	Stop	Stop	Free	Free	Free	Free	Free	Free
RT Channelized	-	-	None	-	-	None	-	-	None	-	-	None
Storage Length	-	-	-	-	-	-	-	-	-	-	-	-
Veh in Median Storage, #	-	0	-	-	0	-	-	0	-	-	0	-
Grade, %	-	0	-	-	0	-	-	0	-	-	0	-
Peak Hour Factor	79	79	79	79	79	79	79	79	79	79	79	79
Heavy Vehicles, %	2	2	2	2	2	2	2	2	2	2	2	2
Mvmt Flow	5	52	29	85	56	0	9	8	57	1	3	1

Major/Minor	Minor2		Minor1		Major1			Major2				
Conflicting Flow All	89	89	4	101	61	37	4	0	0	65	0	0
Stage 1	6	6	-	55	55	-	-	-	-	-	-	-
Stage 2	83	83	-	46	6	-	-	-	-	-	-	-
Critical Hdwy	7.12	6.52	6.22	7.12	6.52	6.22	4.12	-	-	4.12	-	-
Critical Hdwy Stg 1	6.12	5.52	-	6.12	5.52	-	-	-	-	-	-	-
Critical Hdwy Stg 2	6.12	5.52	-	6.12	5.52	-	-	-	-	-	-	-
Follow-up Hdwy	3.518	4.018	3.318	3.518	4.018	3.318	2.218	-	-	2.218	-	-
Pot Cap-1 Maneuver	896	801	1080	880	830	1035	1618	-	-	1537	-	-
Stage 1	1016	891	-	957	849	-	-	-	-	-	-	-
Stage 2	925	826	-	968	891	-	-	-	-	-	-	-
Platoon blocked, %								-	-	-	-	-
Mov Cap-1 Maneuver	845	795	1080	810	824	1035	1618	-	-	1537	-	-
Mov Cap-2 Maneuver	845	795	-	810	824	-	-	-	-	-	-	-
Stage 1	1010	890	-	951	844	-	-	-	-	-	-	-
Stage 2	859	821	-	886	890	-	-	-	-	-	-	-

Approach	EB		WB		NB		SB	
HCM Control Delay, s	9.6		10.3		0.9		1.8	
HCM LOS	A		B					

Minor Lane/Major Mvmt	NBL	NBT	NBR	EBLn1	WBLn1	SBL	SBT	SBR
Capacity (veh/h)	1618	-	-	876	815	1537	-	-
HCM Lane V/C Ratio	0.005	-	-	0.098	0.172	0.001	-	-
HCM Control Delay (s)	7.2	0	-	9.6	10.3	7.3	0	-
HCM Lane LOS	A	A	-	A	B	A	A	-
HCM 95th %tile Q(veh)	0	-	-	0.3	0.6	0	-	-

Heritage at Dalia Ranch
6: Imperial Ave & Worthington Rd/Barioni Blvd

Opening Year 2023 + P1 Proj
Timing Plan: AM PEAK

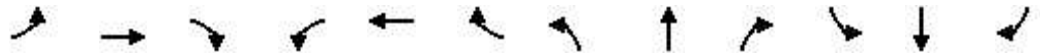

Movement	EBL	EBT	EBR	WBL	WBT	WBR	NBL	NBT	NBR	SBL	SBT	SBR
Lane Configurations		↕	↗		↖	↗	↖	↕	↗	↖	↕	↗
Traffic Volume (veh/h)	70	136	212	54	132	80	93	480	50	46	674	56
Future Volume (veh/h)	70	136	212	54	132	80	93	480	50	46	674	56
Initial Q (Qb), veh	0	0	0	0	0	0	0	0	0	0	0	0
Ped-Bike Adj(A_pbT)	1.00		1.00	1.00		1.00	1.00		1.00	1.00		1.00
Parking Bus, Adj	1.00	1.00	1.00	1.00	1.00	1.00	1.00	1.00	1.00	1.00	1.00	1.00
Work Zone On Approach		No			No			No			No	
Adj Sat Flow, veh/h/ln	1870	1870	1870	1870	1870	1870	1870	1870	1870	1870	1870	1870
Adj Flow Rate, veh/h	79	153	238	61	148	90	104	539	56	52	757	63
Peak Hour Factor	0.89	0.89	0.89	0.89	0.89	0.89	0.89	0.89	0.89	0.89	0.89	0.89
Percent Heavy Veh, %	2	2	2	2	2	2	2	2	2	2	2	2
Cap, veh/h	121	234	306	83	200	243	133	967	100	84	896	75
Arrive On Green	0.19	0.19	0.19	0.15	0.15	0.15	0.07	0.30	0.30	0.05	0.27	0.27
Sat Flow, veh/h	626	1213	1585	538	1305	1585	1781	3250	337	1781	3321	276
Grp Volume(v), veh/h	232	0	238	209	0	90	104	294	301	52	405	415
Grp Sat Flow(s),veh/h/ln	1839	0	1585	1843	0	1585	1781	1777	1810	1781	1777	1821
Q Serve(g_s), s	7.5	0.0	9.2	7.0	0.0	3.3	3.7	9.0	9.1	1.9	13.9	13.9
Cycle Q Clear(g_c), s	7.5	0.0	9.2	7.0	0.0	3.3	3.7	9.0	9.1	1.9	13.9	13.9
Prop In Lane	0.34		1.00	0.29		1.00	1.00		0.19	1.00		0.15
Lane Grp Cap(c), veh/h	355	0	306	283	0	243	133	528	538	84	479	491
V/C Ratio(X)	0.65	0.00	0.78	0.74	0.00	0.37	0.78	0.56	0.56	0.62	0.84	0.85
Avail Cap(c_a), veh/h	512	0	441	513	0	441	138	528	538	138	522	535
HCM Platoon Ratio	1.00	1.00	1.00	1.00	1.00	1.00	1.00	1.00	1.00	1.00	1.00	1.00
Upstream Filter(I)	1.00	0.00	1.00	1.00	0.00	1.00	1.00	1.00	1.00	1.00	1.00	1.00
Uniform Delay (d), s/veh	24.1	0.0	24.8	26.1	0.0	24.6	29.4	19.1	19.1	30.2	22.3	22.3
Incr Delay (d2), s/veh	2.0	0.0	5.4	3.8	0.0	0.9	24.0	1.3	1.3	7.3	11.4	11.2
Initial Q Delay(d3),s/veh	0.0	0.0	0.0	0.0	0.0	0.0	0.0	0.0	0.0	0.0	0.0	0.0
%ile BackOfQ(50%),veh/ln	3.3	0.0	3.7	3.2	0.0	1.2	2.4	3.6	3.7	0.9	6.9	7.0
Unsig. Movement Delay, s/veh												
LnGrp Delay(d),s/veh	26.1	0.0	30.2	29.9	0.0	25.5	53.4	20.4	20.4	37.6	33.7	33.5
LnGrp LOS	C	A	C	C	A	C	D	C	C	D	C	C
Approach Vol, veh/h		470			299			699				872
Approach Delay, s/veh		28.2			28.6			25.3				33.9
Approach LOS		C			C			C				C
Timer - Assigned Phs	1	2		4	5	6		8				
Phs Duration (G+Y+Rc), s	8.0	24.2		17.5	9.8	22.4		14.9				
Change Period (Y+Rc), s	5.0	5.0		5.0	5.0	5.0		5.0				
Max Green Setting (Gmax), s	5.0	19.0		18.0	5.0	19.0		18.0				
Max Q Clear Time (g_c+I1), s	3.9	11.1		11.2	5.7	15.9		9.0				
Green Ext Time (p_c), s	0.0	2.3		1.3	0.0	1.5		1.0				
Intersection Summary												
HCM 6th Ctrl Delay				29.5								
HCM 6th LOS				C								

Intersection												
Intersection Delay, s/veh	19.8											
Intersection LOS	C											

Movement	EBL	EBT	EBR	WBL	WBT	WBR	NBL	NBT	NBR	SBL	SBT	SBR
Lane Configurations		↔	↔		↔	↔		↔			↔	
Traffic Vol, veh/h	64	390	119	11	301	77	0	0	1	106	31	71
Future Vol, veh/h	64	390	119	11	301	77	0	0	1	106	31	71
Peak Hour Factor	0.92	0.92	0.92	0.92	0.92	0.92	0.92	0.92	0.92	0.92	0.92	0.92
Heavy Vehicles, %	2	2	2	2	2	2	2	2	2	2	2	2
Mvmt Flow	70	424	129	12	327	84	0	0	1	115	34	77
Number of Lanes	0	1	1	0	1	1	0	1	0	0	1	0

Approach	EB	WB	NB	SB
Opposing Approach	WB	EB	SB	NB
Opposing Lanes	2	2	1	1
Conflicting Approach Left	SB	NB	EB	WB
Conflicting Lanes Left	1	1	2	2
Conflicting Approach Right	NB	SB	WB	EB
Conflicting Lanes Right	1	1	2	2
HCM Control Delay	25.2	15.3	9.6	13.4
HCM LOS	D	C	A	B

Lane	NBLn1	EBLn1	EBLn2	WBLn1	WBLn2	SBLn1
Vol Left, %	0%	14%	0%	4%	0%	51%
Vol Thru, %	0%	86%	0%	96%	0%	15%
Vol Right, %	100%	0%	100%	0%	100%	34%
Sign Control	Stop	Stop	Stop	Stop	Stop	Stop
Traffic Vol by Lane	1	454	119	312	77	208
LT Vol	0	64	0	11	0	106
Through Vol	0	390	0	301	0	31
RT Vol	1	0	119	0	77	71
Lane Flow Rate	1	493	129	339	84	226
Geometry Grp	2	7	7	7	7	2
Degree of Util (X)	0.002	0.812	0.185	0.575	0.125	0.394
Departure Headway (Hd)	6.515	5.923	5.142	6.105	5.376	6.274
Convergence, Y/N	Yes	Yes	Yes	Yes	Yes	Yes
Cap	545	612	696	590	665	572
Service Time	4.607	3.667	2.885	3.856	3.127	4.328
HCM Lane V/C Ratio	0.002	0.806	0.185	0.575	0.126	0.395
HCM Control Delay	9.6	29.4	9.1	16.9	8.9	13.4
HCM Lane LOS	A	D	A	C	A	B
HCM 95th-tile Q	0	8.2	0.7	3.6	0.4	1.9

Heritage at Dalia Ranch
8: Imperial Ave & Aten Rd

Opening Year 2023 + P1 Proj
Timing Plan: AM PEAK



Movement	EBL	EBT	EBR	WBL	WBT	WBR	NBL	NBT	NBR	SBL	SBT	SBR
Lane Configurations												
Traffic Volume (veh/h)	189	337	63	131	299	144	61	353	67	149	700	382
Future Volume (veh/h)	189	337	63	131	299	144	61	353	67	149	700	382
Initial Q (Qb), veh	0	0	0	0	0	0	0	0	0	0	0	0
Ped-Bike Adj(A_pbT)	1.00		1.00	1.00		1.00	1.00		1.00	1.00		1.00
Parking Bus, Adj	1.00	1.00	1.00	1.00	1.00	1.00	1.00	1.00	1.00	1.00	1.00	1.00
Work Zone On Approach		No			No			No			No	
Adj Sat Flow, veh/h/ln	1870	1870	1870	1870	1870	1870	1870	1870	1870	1870	1870	1870
Adj Flow Rate, veh/h	220	392	73	152	348	167	71	410	78	173	814	444
Peak Hour Factor	0.86	0.86	0.86	0.86	0.86	0.86	0.86	0.86	0.86	0.86	0.86	0.86
Percent Heavy Veh, %	2	2	2	2	2	2	2	2	2	2	2	2
Cap, veh/h	259	704	130	190	460	217	96	890	397	208	1112	496
Arrive On Green	0.15	0.23	0.23	0.11	0.20	0.20	0.05	0.25	0.25	0.12	0.31	0.31
Sat Flow, veh/h	1781	2995	553	1781	2344	1105	1781	3554	1585	1781	3554	1585
Grp Volume(v), veh/h	220	231	234	152	262	253	71	410	78	173	814	444
Grp Sat Flow(s),veh/h/ln	1781	1777	1771	1781	1777	1672	1781	1777	1585	1781	1777	1585
Q Serve(g_s), s	8.3	7.9	8.0	5.7	9.6	9.8	2.7	6.7	2.7	6.5	14.0	18.4
Cycle Q Clear(g_c), s	8.3	7.9	8.0	5.7	9.6	9.8	2.7	6.7	2.7	6.5	14.0	18.4
Prop In Lane	1.00		0.31	1.00		0.66	1.00		1.00	1.00		1.00
Lane Grp Cap(c), veh/h	259	417	416	190	349	328	96	890	397	208	1112	496
V/C Ratio(X)	0.85	0.55	0.56	0.80	0.75	0.77	0.74	0.46	0.20	0.83	0.73	0.90
Avail Cap(c_a), veh/h	259	492	490	233	466	438	130	983	439	208	1139	508
HCM Platoon Ratio	1.00	1.00	1.00	1.00	1.00	1.00	1.00	1.00	1.00	1.00	1.00	1.00
Upstream Filter(I)	1.00	1.00	1.00	1.00	1.00	1.00	1.00	1.00	1.00	1.00	1.00	1.00
Uniform Delay (d), s/veh	28.6	23.1	23.2	29.9	26.0	26.1	32.0	21.8	20.3	29.7	21.0	22.5
Incr Delay (d2), s/veh	22.3	1.1	1.2	14.6	4.7	5.9	13.7	0.4	0.2	24.3	2.4	18.0
Initial Q Delay(d3),s/veh	0.0	0.0	0.0	0.0	0.0	0.0	0.0	0.0	0.0	0.0	0.0	0.0
%ile BackOfQ(50%),veh/ln	5.0	3.2	3.3	3.1	4.3	4.2	1.5	2.7	1.0	4.1	5.8	8.8
Unsig. Movement Delay, s/veh												
LnGrp Delay(d),s/veh	50.8	24.2	24.3	44.5	30.8	32.0	45.7	22.2	20.5	53.9	23.4	40.6
LnGrp LOS	D	C	C	D	C	C	D	C	C	D	C	D
Approach Vol, veh/h		685			667			559			1431	
Approach Delay, s/veh		32.8			34.4			24.9			32.4	
Approach LOS		C			C			C			C	
Timer - Assigned Phs	1	2	3	4	5	6	7	8				
Phs Duration (G+Y+Rc), s	3.0	22.2	12.3	21.1	8.7	26.5	15.0	18.5				
Change Period (Y+Rc), s	5.0	5.0	5.0	5.0	5.0	5.0	5.0	5.0				
Max Green Setting (Gmax), s	3.0	19.0	9.0	19.0	5.0	22.0	10.0	18.0				
Max Q Clear Time (g_c+1/3), s	3.0	8.7	7.7	10.0	4.7	20.4	10.3	11.8				
Green Ext Time (p_c), s	0.0	2.1	0.0	1.9	0.0	1.1	0.0	1.6				
Intersection Summary												
HCM 6th Ctrl Delay											31.6	
HCM 6th LOS											C	

Intersection						
Int Delay, s/veh	2.6					
Movement	EBL	EBT	WBT	WBR	SBL	SBR
Lane Configurations	↖	↑	↗		↖	↗
Traffic Vol, veh/h	3	89	103	23	67	7
Future Vol, veh/h	3	89	103	23	67	7
Conflicting Peds, #/hr	0	0	0	0	0	0
Sign Control	Free	Free	Free	Free	Stop	Stop
RT Channelized	-	None	-	None	-	None
Storage Length	50	-	-	-	0	0
Veh in Median Storage, #	-	0	0	-	0	-
Grade, %	-	0	0	-	0	-
Peak Hour Factor	92	92	92	92	92	92
Heavy Vehicles, %	2	2	2	2	2	2
Mvmt Flow	3	97	112	25	73	8

Major/Minor	Major1	Major2	Minor2		
Conflicting Flow All	137	0	-	0	228
Stage 1	-	-	-	-	125
Stage 2	-	-	-	-	103
Critical Hdwy	4.12	-	-	-	6.42
Critical Hdwy Stg 1	-	-	-	-	5.42
Critical Hdwy Stg 2	-	-	-	-	5.42
Follow-up Hdwy	2.218	-	-	-	3.518
Pot Cap-1 Maneuver	1447	-	-	-	760
Stage 1	-	-	-	-	901
Stage 2	-	-	-	-	921
Platoon blocked, %		-	-	-	
Mov Cap-1 Maneuver	1447	-	-	-	758
Mov Cap-2 Maneuver	-	-	-	-	758
Stage 1	-	-	-	-	899
Stage 2	-	-	-	-	921

Approach	EB	WB	SB
HCM Control Delay, s	0.2	0	10.2
HCM LOS			B

Minor Lane/Major Mvmt	EBL	EBT	WBT	WBR	SBLn1	SBLn2
Capacity (veh/h)	1447	-	-	-	758	926
HCM Lane V/C Ratio	0.002	-	-	-	0.096	0.008
HCM Control Delay (s)	7.5	-	-	-	10.3	8.9
HCM Lane LOS	A	-	-	-	B	A
HCM 95th %tile Q(veh)	0	-	-	-	0.3	0

Heritage at Dalia Ranch
1: SR-86 & Keystone Rd

Opening Year 2023 + P1 Proj
Timing Plan: PM PEAK

Movement	EBL	EBT	EBR	WBL	WBT	WBR	NBL	NBT	NBR	SBL	SBT	SBR
Lane Configurations												
Traffic Volume (veh/h)	41	12	20	33	27	37	10	533	26	52	559	34
Future Volume (veh/h)	41	12	20	33	27	37	10	533	26	52	559	34
Initial Q (Qb), veh	0	0	0	0	0	0	0	0	0	0	0	0
Ped-Bike Adj(A_pbT)	1.00		1.00	1.00		1.00	1.00		1.00	1.00		1.00
Parking Bus, Adj	1.00	1.00	1.00	1.00	1.00	1.00	1.00	1.00	1.00	1.00	1.00	1.00
Work Zone On Approach		No			No			No			No	
Adj Sat Flow, veh/h/ln	1870	1870	1870	1870	1870	1870	1870	1870	1870	1870	1870	1870
Adj Flow Rate, veh/h	46	13	22	37	30	42	11	599	29	58	628	38
Peak Hour Factor	0.89	0.89	0.89	0.89	0.89	0.89	0.89	0.89	0.89	0.89	0.89	0.89
Percent Heavy Veh, %	2	2	2	2	2	2	2	2	2	2	2	2
Cap, veh/h	286	50	57	216	71	82	26	1138	508	113	1312	585
Arrive On Green	0.13	0.13	0.13	0.13	0.13	0.13	0.01	0.32	0.32	0.06	0.37	0.37
Sat Flow, veh/h	795	383	439	461	547	632	1781	3554	1585	1781	3554	1585
Grp Volume(v), veh/h	81	0	0	109	0	0	11	599	29	58	628	38
Grp Sat Flow(s),veh/h/ln	1618	0	0	1639	0	0	1781	1777	1585	1781	1777	1585
Q Serve(g_s), s	0.0	0.0	0.0	0.5	0.0	0.0	0.2	4.3	0.4	1.0	4.2	0.5
Cycle Q Clear(g_c), s	1.3	0.0	0.0	1.8	0.0	0.0	0.2	4.3	0.4	1.0	4.2	0.5
Prop In Lane	0.57		0.27	0.34		0.39	1.00		1.00	1.00		1.00
Lane Grp Cap(c), veh/h	393	0	0	370	0	0	26	1138	508	113	1312	585
V/C Ratio(X)	0.21	0.00	0.00	0.29	0.00	0.00	0.42	0.53	0.06	0.51	0.48	0.06
Avail Cap(c_a), veh/h	1055	0	0	1080	0	0	289	2418	1078	346	2533	1130
HCM Platoon Ratio	1.00	1.00	1.00	1.00	1.00	1.00	1.00	1.00	1.00	1.00	1.00	1.00
Upstream Filter(l)	1.00	0.00	0.00	1.00	0.00	0.00	1.00	1.00	1.00	1.00	1.00	1.00
Uniform Delay (d), s/veh	12.2	0.0	0.0	12.4	0.0	0.0	15.1	8.6	7.3	14.0	7.5	6.3
Incr Delay (d2), s/veh	0.3	0.0	0.0	0.4	0.0	0.0	10.6	0.4	0.0	3.6	0.3	0.0
Initial Q Delay(d3),s/veh	0.0	0.0	0.0	0.0	0.0	0.0	0.0	0.0	0.0	0.0	0.0	0.0
%ile BackOfQ(50%),veh/ln	0.4	0.0	0.0	0.6	0.0	0.0	0.1	1.1	0.1	0.4	1.0	0.1
Unsig. Movement Delay, s/veh												
LnGrp Delay(d),s/veh	12.5	0.0	0.0	12.9	0.0	0.0	25.7	9.0	7.3	17.6	7.7	6.3
LnGrp LOS	B	A	A	B	A	A	C	A	A	B	A	A
Approach Vol, veh/h		81			109			639			724	
Approach Delay, s/veh		12.5			12.9			9.2			8.4	
Approach LOS		B			B			A			A	
Timer - Assigned Phs	1	2		4	5	6		8				
Phs Duration (G+Y+Rc), s	7.0	14.9		9.0	5.5	16.4		9.0				
Change Period (Y+Rc), s	5.0	5.0		5.0	5.0	5.0		5.0				
Max Green Setting (Gmax), s	6.0	21.0		18.0	5.0	22.0		18.0				
Max Q Clear Time (g_c+I1), s	3.0	6.3		3.3	2.2	6.2		3.8				
Green Ext Time (p_c), s	0.0	3.6		0.3	0.0	4.0		0.4				
Intersection Summary												
HCM 6th Ctrl Delay				9.3								
HCM 6th LOS				A								

Intersection												
Int Delay, s/veh	0.3											
Movement	EBL	EBT	EBR	WBL	WBT	WBR	NBL	NBT	NBR	SBL	SBT	SBR
Lane Configurations		↕			↕		↕	↕		↕	↕	
Traffic Vol, veh/h	6	4	0	7	0	5	1	571	7	6	595	17
Future Vol, veh/h	6	4	0	7	0	5	1	571	7	6	595	17
Conflicting Peds, #/hr	0	0	0	0	0	0	0	0	0	0	0	0
Sign Control	Stop	Stop	Stop	Stop	Stop	Stop	Free	Free	Free	Free	Free	Free
RT Channelized	-	-	None	-	-	None	-	-	None	-	-	None
Storage Length	-	-	-	-	-	-	50	-	-	50	-	-
Veh in Median Storage, #	-	1	-	-	1	-	-	0	-	-	0	-
Grade, %	-	0	-	-	0	-	-	0	-	-	0	-
Peak Hour Factor	92	92	92	92	92	92	92	92	92	92	92	92
Heavy Vehicles, %	2	2	2	2	2	2	2	2	2	2	2	2
Mvmt Flow	7	4	0	8	0	5	1	621	8	7	647	18

Major/Minor	Minor2		Minor1		Major1		Major2					
Conflicting Flow All	983	1301	333	967	1306	315	665	0	0	629	0	0
Stage 1	670	670	-	627	627	-	-	-	-	-	-	-
Stage 2	313	631	-	340	679	-	-	-	-	-	-	-
Critical Hdwy	7.54	6.54	6.94	7.54	6.54	6.94	4.14	-	-	4.14	-	-
Critical Hdwy Stg 1	6.54	5.54	-	6.54	5.54	-	-	-	-	-	-	-
Critical Hdwy Stg 2	6.54	5.54	-	6.54	5.54	-	-	-	-	-	-	-
Follow-up Hdwy	3.52	4.02	3.32	3.52	4.02	3.32	2.22	-	-	2.22	-	-
Pot Cap-1 Maneuver	203	160	663	209	159	681	920	-	-	949	-	-
Stage 1	413	454	-	438	474	-	-	-	-	-	-	-
Stage 2	672	473	-	648	449	-	-	-	-	-	-	-
Platoon blocked, %								-	-	-	-	-
Mov Cap-1 Maneuver	200	159	663	205	158	681	920	-	-	949	-	-
Mov Cap-2 Maneuver	315	282	-	325	282	-	-	-	-	-	-	-
Stage 1	413	451	-	438	474	-	-	-	-	-	-	-
Stage 2	666	473	-	637	446	-	-	-	-	-	-	-

Approach	EB		WB		NB		SB	
HCM Control Delay, s	17.4		13.9		0		0.1	
HCM LOS	C		B					

Minor Lane/Major Mvmt	NBL	NBT	NBR	EBLn1	WBLn1	SBL	SBT	SBR
Capacity (veh/h)	920	-	-	301	416	949	-	-
HCM Lane V/C Ratio	0.001	-	-	0.036	0.031	0.007	-	-
HCM Control Delay (s)	8.9	-	-	17.4	13.9	8.8	-	-
HCM Lane LOS	A	-	-	C	B	A	-	-
HCM 95th %tile Q(veh)	0	-	-	0.1	0.1	0	-	-

Intersection						
Int Delay, s/veh	0.7					
Movement	WBL	WBR	NBT	NBR	SBL	SBT
Lane Configurations	↔		↑↓		↔	↑↑
Traffic Vol, veh/h	20	10	572	30	30	559
Future Vol, veh/h	20	10	572	30	30	559
Conflicting Peds, #/hr	0	0	0	0	0	0
Sign Control	Stop	Stop	Free	Free	Free	Free
RT Channelized	-	None	-	None	-	None
Storage Length	0	-	-	-	140	-
Veh in Median Storage, #	0	-	0	-	-	0
Grade, %	0	-	0	-	-	0
Peak Hour Factor	91	91	91	91	91	91
Heavy Vehicles, %	2	2	2	2	2	2
Mvmt Flow	22	11	629	33	33	614

Major/Minor	Minor1	Major1	Major2			
Conflicting Flow All	1019	331	0	0	662	0
Stage 1	646	-	-	-	-	-
Stage 2	373	-	-	-	-	-
Critical Hdwy	6.84	6.94	-	-	4.14	-
Critical Hdwy Stg 1	5.84	-	-	-	-	-
Critical Hdwy Stg 2	5.84	-	-	-	-	-
Follow-up Hdwy	3.52	3.32	-	-	2.22	-
Pot Cap-1 Maneuver	233	665	-	-	922	-
Stage 1	484	-	-	-	-	-
Stage 2	666	-	-	-	-	-
Platoon blocked, %			-	-		
Mov Cap-1 Maneuver	225	665	-	-	922	-
Mov Cap-2 Maneuver	225	-	-	-	-	-
Stage 1	484	-	-	-	-	-
Stage 2	642	-	-	-	-	-

Approach	WB	NB	SB
HCM Control Delay, s	19.1	0	0.5
HCM LOS	C		

Minor Lane/Major Mvmt	NBT	NBRWBLn1	SBL	SBT
Capacity (veh/h)	-	-	289	922
HCM Lane V/C Ratio	-	-	0.114	0.036
HCM Control Delay (s)	-	-	19.1	9
HCM Lane LOS	-	-	C	A
HCM 95th %tile Q(veh)	-	-	0.4	0.1

Heritage at Dalia Ranch
4: Imperial Ave & Neckel Rd

Opening Year 2023 + P1 Proj
Timing Plan: PM PEAK

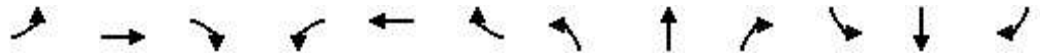

Movement	EBL	EBT	EBR	WBL	WBT	WBR	NBL	NBT	NBR	SBL	SBT	SBR
Lane Configurations		↕			↕		↕	↕		↕	↕	
Traffic Volume (veh/h)	22	26	38	82	20	46	70	555	83	29	496	45
Future Volume (veh/h)	22	26	38	82	20	46	70	555	83	29	496	45
Initial Q (Qb), veh	0	0	0	0	0	0	0	0	0	0	0	0
Ped-Bike Adj(A_pbT)	1.00		1.00	1.00		1.00	1.00		1.00	1.00		1.00
Parking Bus, Adj	1.00	1.00	1.00	1.00	1.00	1.00	1.00	1.00	1.00	1.00	1.00	1.00
Work Zone On Approach		No			No			No			No	
Adj Sat Flow, veh/h/ln	1870	1870	1870	1870	1870	1870	1870	1870	1870	1870	1870	1870
Adj Flow Rate, veh/h	24	28	41	89	22	50	76	603	90	32	539	49
Peak Hour Factor	0.92	0.92	0.92	0.92	0.92	0.92	0.92	0.92	0.92	0.92	0.92	0.92
Percent Heavy Veh, %	2	2	2	2	2	2	2	2	2	2	2	2
Cap, veh/h	35	40	59	123	30	69	124	897	134	66	846	77
Arrive On Green	0.08	0.08	0.08	0.13	0.13	0.13	0.07	0.29	0.29	0.04	0.26	0.26
Sat Flow, veh/h	442	516	755	954	236	536	1781	3102	462	1781	3295	299
Grp Volume(v), veh/h	93	0	0	161	0	0	76	345	348	32	290	298
Grp Sat Flow(s),veh/h/ln	1712	0	0	1726	0	0	1781	1777	1787	1781	1777	1817
Q Serve(g_s), s	2.3	0.0	0.0	3.8	0.0	0.0	1.8	7.3	7.4	0.8	6.2	6.2
Cycle Q Clear(g_c), s	2.3	0.0	0.0	3.8	0.0	0.0	1.8	7.3	7.4	0.8	6.2	6.2
Prop In Lane	0.26		0.44	0.55		0.31	1.00		0.26	1.00		0.16
Lane Grp Cap(c), veh/h	134	0	0	222	0	0	124	514	517	66	456	467
V/C Ratio(X)	0.70	0.00	0.00	0.72	0.00	0.00	0.61	0.67	0.67	0.49	0.64	0.64
Avail Cap(c_a), veh/h	719	0	0	725	0	0	208	788	792	208	788	805
HCM Platoon Ratio	1.00	1.00	1.00	1.00	1.00	1.00	1.00	1.00	1.00	1.00	1.00	1.00
Upstream Filter(l)	1.00	0.00	0.00	1.00	0.00	0.00	1.00	1.00	1.00	1.00	1.00	1.00
Uniform Delay (d), s/veh	19.3	0.0	0.0	17.9	0.0	0.0	19.4	13.4	13.4	20.2	14.1	14.2
Incr Delay (d2), s/veh	6.3	0.0	0.0	4.4	0.0	0.0	4.9	1.5	1.5	5.5	1.5	1.5
Initial Q Delay(d3),s/veh	0.0	0.0	0.0	0.0	0.0	0.0	0.0	0.0	0.0	0.0	0.0	0.0
%ile BackOfQ(50%),veh/ln	1.0	0.0	0.0	1.6	0.0	0.0	0.8	2.6	2.6	0.4	2.2	2.3
Unsig. Movement Delay, s/veh												
LnGrp Delay(d),s/veh	25.6	0.0	0.0	22.4	0.0	0.0	24.2	15.0	15.0	25.7	15.6	15.6
LnGrp LOS	C	A	A	C	A	A	C	B	B	C	B	B
Approach Vol, veh/h		93			161			769			620	
Approach Delay, s/veh		25.6			22.4			15.9			16.1	
Approach LOS		C			C			B			B	
Timer - Assigned Phs	1	2		4	5	6		8				
Phs Duration (G+Y+Rc), s	6.6	17.4		8.3	8.0	16.0		10.5				
Change Period (Y+Rc), s	5.0	5.0		5.0	5.0	5.0		5.0				
Max Green Setting (Gmax), s	5.0	19.0		18.0	5.0	19.0		18.0				
Max Q Clear Time (g_c+I1), s	2.8	9.4		4.3	3.8	8.2		5.8				
Green Ext Time (p_c), s	0.0	3.0		0.3	0.0	2.7		0.6				
Intersection Summary												
HCM 6th Ctrl Delay				17.2								
HCM 6th LOS				B								

Intersection												
Int Delay, s/veh	7.4											
Movement	EBL	EBT	EBR	WBL	WBT	WBR	NBL	NBT	NBR	SBL	SBT	SBR
Lane Configurations		↕			↕			↕			↕	
Traffic Vol, veh/h	2	38	8	28	44	1	5	6	18	0	5	7
Future Vol, veh/h	2	38	8	28	44	1	5	6	18	0	5	7
Conflicting Peds, #/hr	0	0	0	0	0	0	0	0	0	0	0	0
Sign Control	Stop	Stop	Stop	Stop	Stop	Stop	Free	Free	Free	Free	Free	Free
RT Channelized	-	-	None	-	-	None	-	-	None	-	-	None
Storage Length	-	-	-	-	-	-	-	-	-	-	-	-
Veh in Median Storage, #	-	0	-	-	0	-	-	0	-	-	0	-
Grade, %	-	0	-	-	0	-	-	0	-	-	0	-
Peak Hour Factor	79	79	79	79	79	79	79	79	79	79	79	79
Heavy Vehicles, %	2	2	2	2	2	2	2	2	2	2	2	2
Mvmt Flow	3	48	10	35	56	1	6	8	23	0	6	9

Major/Minor	Minor2		Minor1		Major1			Major2				
Conflicting Flow All	71	54	11	72	47	20	15	0	0	31	0	0
Stage 1	11	11	-	32	32	-	-	-	-	-	-	-
Stage 2	60	43	-	40	15	-	-	-	-	-	-	-
Critical Hdwy	7.12	6.52	6.22	7.12	6.52	6.22	4.12	-	-	4.12	-	-
Critical Hdwy Stg 1	6.12	5.52	-	6.12	5.52	-	-	-	-	-	-	-
Critical Hdwy Stg 2	6.12	5.52	-	6.12	5.52	-	-	-	-	-	-	-
Follow-up Hdwy	3.518	4.018	3.318	3.518	4.018	3.318	2.218	-	-	2.218	-	-
Pot Cap-1 Maneuver	920	837	1070	919	845	1058	1603	-	-	1582	-	-
Stage 1	1010	886	-	984	868	-	-	-	-	-	-	-
Stage 2	951	859	-	975	883	-	-	-	-	-	-	-
Platoon blocked, %								-	-	-	-	-
Mov Cap-1 Maneuver	869	834	1070	868	842	1058	1603	-	-	1582	-	-
Mov Cap-2 Maneuver	869	834	-	868	842	-	-	-	-	-	-	-
Stage 1	1006	886	-	980	865	-	-	-	-	-	-	-
Stage 2	885	856	-	913	883	-	-	-	-	-	-	-

Approach	EB		WB		NB		SB	
HCM Control Delay, s	9.5		9.7		1.3		0	
HCM LOS	A		A					

Minor Lane/Major Mvmt	NBL	NBT	NBR	EBLn1	WBLn1	SBL	SBT	SBR
Capacity (veh/h)	1603	-	-	867	854	1582	-	-
HCM Lane V/C Ratio	0.004	-	-	0.07	0.108	-	-	-
HCM Control Delay (s)	7.3	0	-	9.5	9.7	0	-	-
HCM Lane LOS	A	A	-	A	A	A	-	-
HCM 95th %tile Q(veh)	0	-	-	0.2	0.4	0	-	-

Heritage at Dalia Ranch
6: Imperial Ave & Worthington Rd/Barioni Blvd

Opening Year 2023 + P1 Proj
Timing Plan: PM PEAK

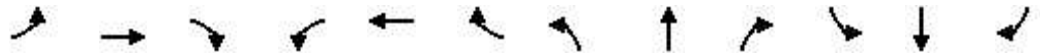

Movement	EBL	EBT	EBR	WBL	WBT	WBR	NBL	NBT	NBR	SBL	SBT	SBR
Lane Configurations		↖	↗		↖	↗	↖	↗	↖	↗	↖	↗
Traffic Volume (veh/h)	48	74	105	54	112	59	112	716	14	32	622	63
Future Volume (veh/h)	48	74	105	54	112	59	112	716	14	32	622	63
Initial Q (Qb), veh	0	0	0	0	0	0	0	0	0	0	0	0
Ped-Bike Adj(A_pbT)	1.00		1.00	1.00		1.00	1.00		1.00	1.00		1.00
Parking Bus, Adj	1.00	1.00	1.00	1.00	1.00	1.00	1.00	1.00	1.00	1.00	1.00	1.00
Work Zone On Approach		No			No			No			No	
Adj Sat Flow, veh/h/ln	1870	1870	1870	1870	1870	1870	1870	1870	1870	1870	1870	1870
Adj Flow Rate, veh/h	53	81	115	59	123	65	123	787	15	35	684	69
Peak Hour Factor	0.91	0.91	0.91	0.91	0.91	0.91	0.91	0.91	0.91	0.91	0.91	0.91
Percent Heavy Veh, %	2	2	2	2	2	2	2	2	2	2	2	2
Cap, veh/h	87	133	190	86	179	228	157	1155	22	68	892	90
Arrive On Green	0.12	0.12	0.12	0.14	0.14	0.14	0.09	0.32	0.32	0.04	0.27	0.27
Sat Flow, veh/h	725	1109	1585	597	1244	1585	1781	3567	68	1781	3260	329
Grp Volume(v), veh/h	134	0	115	182	0	65	123	392	410	35	373	380
Grp Sat Flow(s),veh/h/ln	1834	0	1585	1841	0	1585	1781	1777	1858	1781	1777	1811
Q Serve(g_s), s	3.7	0.0	3.7	5.0	0.0	2.0	3.6	10.2	10.2	1.0	10.3	10.3
Cycle Q Clear(g_c), s	3.7	0.0	3.7	5.0	0.0	2.0	3.6	10.2	10.2	1.0	10.3	10.3
Prop In Lane	0.40		1.00	0.32		1.00	1.00		0.04	1.00		0.18
Lane Grp Cap(c), veh/h	219	0	190	265	0	228	157	575	602	68	486	495
V/C Ratio(X)	0.61	0.00	0.61	0.69	0.00	0.28	0.78	0.68	0.68	0.52	0.77	0.77
Avail Cap(c_a), veh/h	618	0	534	621	0	534	200	632	661	167	599	611
HCM Platoon Ratio	1.00	1.00	1.00	1.00	1.00	1.00	1.00	1.00	1.00	1.00	1.00	1.00
Upstream Filter(l)	1.00	0.00	1.00	1.00	0.00	1.00	1.00	1.00	1.00	1.00	1.00	1.00
Uniform Delay (d), s/veh	22.3	0.0	22.3	21.7	0.0	20.4	23.8	15.7	15.7	25.2	17.8	17.8
Incr Delay (d2), s/veh	2.7	0.0	3.1	3.2	0.0	0.7	14.2	2.6	2.5	6.0	4.7	4.7
Initial Q Delay(d3),s/veh	0.0	0.0	0.0	0.0	0.0	0.0	0.0	0.0	0.0	0.0	0.0	0.0
%ile BackOfQ(50%),veh/ln	1.6	0.0	1.4	2.2	0.0	0.7	2.0	4.0	4.2	0.5	4.4	4.4
Unsig. Movement Delay, s/veh												
LnGrp Delay(d),s/veh	25.1	0.0	25.4	24.9	0.0	21.1	38.0	18.3	18.2	31.2	22.6	22.5
LnGrp LOS	C	A	C	C	A	C	D	B	B	C	C	C
Approach Vol, veh/h		249			247			925			788	
Approach Delay, s/veh		25.2			23.9			20.9			22.9	
Approach LOS		C			C			C			C	
Timer - Assigned Phs	1	2		4	5	6		8				
Phs Duration (G+Y+Rc), s	7.0	22.3		11.4	9.7	19.6		12.7				
Change Period (Y+Rc), s	5.0	5.0		5.0	5.0	5.0		5.0				
Max Green Setting (Gmax), s	5.0	19.0		18.0	6.0	18.0		18.0				
Max Q Clear Time (g_c+I1), s	3.0	12.2		5.7	5.6	12.3		7.0				
Green Ext Time (p_c), s	0.0	2.8		0.8	0.0	2.3		0.9				
Intersection Summary												
HCM 6th Ctrl Delay			22.4									
HCM 6th LOS			C									

Intersection												
Intersection Delay, s/veh	10.7											
Intersection LOS	B											

Movement	EBL	EBT	EBR	WBL	WBT	WBR	NBL	NBT	NBR	SBL	SBT	SBR
Lane Configurations		↔	↔		↔	↔		↔			↔	
Traffic Vol, veh/h	34	187	33	27	215	34	1	0	0	37	5	29
Future Vol, veh/h	34	187	33	27	215	34	1	0	0	37	5	29
Peak Hour Factor	0.80	0.80	0.80	0.80	0.80	0.80	0.80	0.80	0.80	0.80	0.80	0.80
Heavy Vehicles, %	2	2	2	2	2	2	2	2	2	2	2	2
Mvmt Flow	43	234	41	34	269	43	1	0	0	46	6	36
Number of Lanes	0	1	1	0	1	1	0	1	0	0	1	0

Approach	EB	WB	NB	SB
Opposing Approach	WB	EB	SB	NB
Opposing Lanes	2	2	1	1
Conflicting Approach Left	SB	NB	EB	WB
Conflicting Lanes Left	1	1	2	2
Conflicting Approach Right	NB	SB	WB	EB
Conflicting Lanes Right	1	1	2	2
HCM Control Delay	10.7	11.1	8.9	9.2
HCM LOS	B	B	A	A

Lane	NBLn1	EBLn1	EBLn2	WBLn1	WBLn2	SBLn1
Vol Left, %	100%	15%	0%	11%	0%	52%
Vol Thru, %	0%	85%	0%	89%	0%	7%
Vol Right, %	0%	0%	100%	0%	100%	41%
Sign Control	Stop	Stop	Stop	Stop	Stop	Stop
Traffic Vol by Lane	1	221	33	242	34	71
LT Vol	1	34	0	27	0	37
Through Vol	0	187	0	215	0	5
RT Vol	0	0	33	0	34	29
Lane Flow Rate	1	276	41	302	42	89
Geometry Grp	2	7	7	7	7	2
Degree of Util (X)	0.002	0.395	0.05	0.429	0.051	0.131
Departure Headway (Hd)	5.82	5.145	4.363	5.102	4.342	5.311
Convergence, Y/N	Yes	Yes	Yes	Yes	Yes	Yes
Cap	611	699	818	705	822	673
Service Time	3.893	2.884	2.103	2.84	2.08	3.364
HCM Lane V/C Ratio	0.002	0.395	0.05	0.428	0.051	0.132
HCM Control Delay	8.9	11.2	7.3	11.6	7.3	9.2
HCM Lane LOS	A	B	A	B	A	A
HCM 95th-tile Q	0	1.9	0.2	2.2	0.2	0.4

Heritage at Dalia Ranch
8: Imperial Ave & Aten Rd

Opening Year 2023 + P1 Proj
Timing Plan: PM PEAK



Movement	EBL	EBT	EBR	WBL	WBT	WBR	NBL	NBT	NBR	SBL	SBT	SBR
Lane Configurations												
Traffic Volume (veh/h)	197	276	68	178	288	130	78	698	149	117	557	214
Future Volume (veh/h)	197	276	68	178	288	130	78	698	149	117	557	214
Initial Q (Qb), veh	0	0	0	0	0	0	0	0	0	0	0	0
Ped-Bike Adj(A_pbT)	1.00		1.00	1.00		1.00	1.00		1.00	1.00		1.00
Parking Bus, Adj	1.00	1.00	1.00	1.00	1.00	1.00	1.00	1.00	1.00	1.00	1.00	1.00
Work Zone On Approach		No		No		No		No		No		No
Adj Sat Flow, veh/h/ln	1870	1870	1870	1870	1870	1870	1870	1870	1870	1870	1870	1870
Adj Flow Rate, veh/h	210	294	72	189	306	138	83	743	159	124	593	228
Peak Hour Factor	0.94	0.94	0.94	0.94	0.94	0.94	0.94	0.94	0.94	0.94	0.94	0.94
Percent Heavy Veh, %	2	2	2	2	2	2	2	2	2	2	2	2
Cap, veh/h	257	552	133	235	437	193	109	940	419	158	1039	463
Arrive On Green	0.14	0.19	0.19	0.13	0.18	0.18	0.06	0.26	0.26	0.09	0.29	0.29
Sat Flow, veh/h	1781	2840	684	1781	2399	1058	1781	3554	1585	1781	3554	1585
Grp Volume(v), veh/h	210	182	184	189	225	219	83	743	159	124	593	228
Grp Sat Flow(s),veh/h/ln	1781	1777	1747	1781	1777	1680	1781	1777	1585	1781	1777	1585
Q Serve(g_s), s	7.1	5.7	5.9	6.4	7.4	7.7	2.9	12.1	5.1	4.3	8.9	7.4
Cycle Q Clear(g_c), s	7.1	5.7	5.9	6.4	7.4	7.7	2.9	12.1	5.1	4.3	8.9	7.4
Prop In Lane	1.00		0.39	1.00		0.63	1.00		1.00	1.00		1.00
Lane Grp Cap(c), veh/h	257	345	340	235	323	306	109	940	419	158	1039	463
V/C Ratio(X)	0.82	0.53	0.54	0.80	0.70	0.72	0.76	0.79	0.38	0.78	0.57	0.49
Avail Cap(c_a), veh/h	314	512	504	314	512	484	171	1081	482	200	1138	508
HCM Platoon Ratio	1.00	1.00	1.00	1.00	1.00	1.00	1.00	1.00	1.00	1.00	1.00	1.00
Upstream Filter(l)	1.00	1.00	1.00	1.00	1.00	1.00	1.00	1.00	1.00	1.00	1.00	1.00
Uniform Delay (d), s/veh	25.9	22.6	22.6	26.3	23.9	24.0	28.9	21.4	18.8	27.9	18.8	18.3
Incr Delay (d2), s/veh	13.0	1.2	1.3	10.6	2.7	3.1	10.5	3.5	0.6	14.5	0.6	0.8
Initial Q Delay(d3),s/veh	0.0	0.0	0.0	0.0	0.0	0.0	0.0	0.0	0.0	0.0	0.0	0.0
%ile BackOfQ(50%),veh/ln	3.8	2.4	2.4	3.3	3.1	3.1	1.5	5.1	1.8	2.4	3.4	2.6
Unsig. Movement Delay, s/veh												
LnGrp Delay(d),s/veh	38.9	23.8	24.0	36.9	26.6	27.2	39.3	24.9	19.3	42.4	19.3	19.1
LnGrp LOS	D	C	C	D	C	C	D	C	B	D	B	B
Approach Vol, veh/h		576			633			985			945	
Approach Delay, s/veh		29.4			29.9			25.2			22.3	
Approach LOS		C			C			C			C	
Timer - Assigned Phs	1	2	3	4	5	6	7	8				
Phs Duration (G+Y+Rc), s	10.5	21.5	13.2	17.1	8.8	23.2	14.0	16.4				
Change Period (Y+Rc), s	5.0	5.0	5.0	5.0	5.0	5.0	5.0	5.0				
Max Green Setting (Gmax), s	19.0	19.0	11.0	18.0	6.0	20.0	11.0	18.0				
Max Q Clear Time (g_c+1/3), s	14.1	14.1	8.4	7.9	4.9	10.9	9.1	9.7				
Green Ext Time (p_c), s	0.0	2.4	0.1	1.5	0.0	3.3	0.1	1.7				
Intersection Summary												
HCM 6th Ctrl Delay											26.0	
HCM 6th LOS											C	

Intersection						
Int Delay, s/veh	2.2					
Movement	EBL	EBT	WBT	WBR	SBL	SBR
Lane Configurations	↔	↑	↔		↔	↔
Traffic Vol, veh/h	8	42	59	76	43	5
Future Vol, veh/h	8	42	59	76	43	5
Conflicting Peds, #/hr	0	0	0	0	0	0
Sign Control	Free	Free	Free	Free	Stop	Stop
RT Channelized	-	None	-	None	-	None
Storage Length	50	-	-	-	0	0
Veh in Median Storage, #	-	0	0	-	0	-
Grade, %	-	0	0	-	0	-
Peak Hour Factor	92	92	92	92	92	92
Heavy Vehicles, %	2	2	2	2	2	2
Mvmt Flow	9	46	64	83	47	5

Major/Minor	Major1	Major2	Minor2		
Conflicting Flow All	147	0	-	0	170
Stage 1	-	-	-	-	106
Stage 2	-	-	-	-	64
Critical Hdwy	4.12	-	-	-	6.42
Critical Hdwy Stg 1	-	-	-	-	5.42
Critical Hdwy Stg 2	-	-	-	-	5.42
Follow-up Hdwy	2.218	-	-	-	3.518
Pot Cap-1 Maneuver	1435	-	-	-	820
Stage 1	-	-	-	-	918
Stage 2	-	-	-	-	959
Platoon blocked, %		-	-	-	
Mov Cap-1 Maneuver	1435	-	-	-	815
Mov Cap-2 Maneuver	-	-	-	-	815
Stage 1	-	-	-	-	912
Stage 2	-	-	-	-	959

Approach	EB	WB	SB
HCM Control Delay, s	1.2	0	9.6
HCM LOS			A

Minor Lane/Major Mvmt	EBL	EBT	WBT	WBR	SBLn1	SBLn2
Capacity (veh/h)	1435	-	-	-	815	948
HCM Lane V/C Ratio	0.006	-	-	-	0.057	0.006
HCM Control Delay (s)	7.5	-	-	-	9.7	8.8
HCM Lane LOS	A	-	-	-	A	A
HCM 95th %tile Q(veh)	0	-	-	-	0.2	0

Heritage at Dalia Ranch
1: SR-86 & Keystone Rd

Opening Year 2024
Timing Plan: AM PEAK

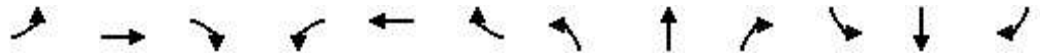

Movement	EBL	EBT	EBR	WBL	WBT	WBR	NBL	NBT	NBR	SBL	SBT	SBR
Lane Configurations		↕			↕		↕	↕↕	↕	↕	↕↕	↕
Traffic Volume (veh/h)	33	33	11	19	24	43	19	445	50	46	519	38
Future Volume (veh/h)	33	33	11	19	24	43	19	445	50	46	519	38
Initial Q (Qb), veh	0	0	0	0	0	0	0	0	0	0	0	0
Ped-Bike Adj(A_pbT)	1.00		1.00	1.00		1.00	1.00		1.00	1.00		1.00
Parking Bus, Adj	1.00	1.00	1.00	1.00	1.00	1.00	1.00	1.00	1.00	1.00	1.00	1.00
Work Zone On Approach		No			No			No			No	
Adj Sat Flow, veh/h/ln	1870	1870	1870	1870	1870	1870	1870	1870	1870	1870	1870	1870
Adj Flow Rate, veh/h	37	37	12	21	27	48	21	494	56	51	577	42
Peak Hour Factor	0.90	0.90	0.90	0.90	0.90	0.90	0.90	0.90	0.90	0.90	0.90	0.90
Percent Heavy Veh, %	2	2	2	2	2	2	2	2	2	2	2	2
Cap, veh/h	260	111	31	190	74	110	48	1009	450	104	1121	500
Arrive On Green	0.13	0.13	0.13	0.13	0.13	0.13	0.03	0.28	0.28	0.06	0.32	0.32
Sat Flow, veh/h	598	831	232	272	550	823	1781	3554	1585	1781	3554	1585
Grp Volume(v), veh/h	86	0	0	96	0	0	21	494	56	51	577	42
Grp Sat Flow(s),veh/h/ln	1660	0	0	1645	0	0	1781	1777	1585	1781	1777	1585
Q Serve(g_s), s	0.0	0.0	0.0	0.2	0.0	0.0	0.3	3.3	0.8	0.8	3.8	0.5
Cycle Q Clear(g_c), s	1.2	0.0	0.0	1.5	0.0	0.0	0.3	3.3	0.8	0.8	3.8	0.5
Prop In Lane	0.43		0.14	0.22		0.50	1.00		1.00	1.00		1.00
Lane Grp Cap(c), veh/h	402	0	0	373	0	0	48	1009	450	104	1121	500
V/C Ratio(X)	0.21	0.00	0.00	0.26	0.00	0.00	0.44	0.49	0.12	0.49	0.51	0.08
Avail Cap(c_a), veh/h	1172	0	0	1163	0	0	311	2235	997	311	2235	997
HCM Platoon Ratio	1.00	1.00	1.00	1.00	1.00	1.00	1.00	1.00	1.00	1.00	1.00	1.00
Upstream Filter(l)	1.00	0.00	0.00	1.00	0.00	0.00	1.00	1.00	1.00	1.00	1.00	1.00
Uniform Delay (d), s/veh	11.3	0.0	0.0	11.4	0.0	0.0	13.7	8.5	7.6	13.1	8.0	6.9
Incr Delay (d2), s/veh	0.3	0.0	0.0	0.4	0.0	0.0	6.2	0.4	0.1	3.6	0.4	0.1
Initial Q Delay(d3),s/veh	0.0	0.0	0.0	0.0	0.0	0.0	0.0	0.0	0.0	0.0	0.0	0.0
%ile BackOfQ(50%),veh/ln	0.4	0.0	0.0	0.4	0.0	0.0	0.2	0.9	0.2	0.3	0.9	0.1
Unsig. Movement Delay, s/veh												
LnGrp Delay(d),s/veh	11.5	0.0	0.0	11.7	0.0	0.0	19.9	8.9	7.7	16.6	8.4	7.0
LnGrp LOS	B	A	A	B	A	A	B	A	A	B	A	A
Approach Vol, veh/h		86			96			571			670	
Approach Delay, s/veh		11.5			11.7			9.2			8.9	
Approach LOS		B			B			A			A	
Timer - Assigned Phs	1	2		4	5	6		8				
Phs Duration (G+Y+Rc), s	6.7	13.1		8.8	5.8	14.0		8.8				
Change Period (Y+Rc), s	5.0	5.0		5.0	5.0	5.0		5.0				
Max Green Setting (Gmax), s	5.0	18.0		18.0	5.0	18.0		18.0				
Max Q Clear Time (g_c+I1), s	2.8	5.3		3.2	2.3	5.8		3.5				
Green Ext Time (p_c), s	0.0	2.8		0.3	0.0	3.2		0.4				
Intersection Summary												
HCM 6th Ctrl Delay				9.4								
HCM 6th LOS				A								

Intersection												
Int Delay, s/veh	0.4											
Movement	EBL	EBT	EBR	WBL	WBT	WBR	NBL	NBT	NBR	SBL	SBT	SBR
Lane Configurations		↕			↕		↕	↕		↕	↕	
Traffic Vol, veh/h	20	3	2	1	2	5	0	513	1	1	524	7
Future Vol, veh/h	20	3	2	1	2	5	0	513	1	1	524	7
Conflicting Peds, #/hr	0	0	0	0	0	0	0	0	0	0	0	0
Sign Control	Stop	Stop	Stop	Stop	Stop	Stop	Free	Free	Free	Free	Free	Free
RT Channelized	-	-	None	-	-	None	-	-	None	-	-	None
Storage Length	-	-	-	-	-	-	50	-	-	50	-	-
Veh in Median Storage, #	-	1	-	-	1	-	-	0	-	-	0	-
Grade, %	-	0	-	-	0	-	-	0	-	-	0	-
Peak Hour Factor	94	94	94	94	94	94	94	94	94	94	94	94
Heavy Vehicles, %	2	2	2	2	2	2	2	2	2	2	2	2
Mvmt Flow	21	3	2	1	2	5	0	546	1	1	557	7

Major/Minor	Minor2		Minor1		Major1			Major2				
Conflicting Flow All	837	1110	282	829	1113	274	564	0	0	547	0	0
Stage 1	563	563	-	547	547	-	-	-	-	-	-	-
Stage 2	274	547	-	282	566	-	-	-	-	-	-	-
Critical Hdwy	7.54	6.54	6.94	7.54	6.54	6.94	4.14	-	-	4.14	-	-
Critical Hdwy Stg 1	6.54	5.54	-	6.54	5.54	-	-	-	-	-	-	-
Critical Hdwy Stg 2	6.54	5.54	-	6.54	5.54	-	-	-	-	-	-	-
Follow-up Hdwy	3.52	4.02	3.32	3.52	4.02	3.32	2.22	-	-	2.22	-	-
Pot Cap-1 Maneuver	259	208	715	263	207	724	1004	-	-	1018	-	-
Stage 1	478	507	-	489	516	-	-	-	-	-	-	-
Stage 2	709	516	-	701	506	-	-	-	-	-	-	-
Platoon blocked, %								-	-	-	-	-
Mov Cap-1 Maneuver	256	208	715	260	207	724	1004	-	-	1018	-	-
Mov Cap-2 Maneuver	369	328	-	374	327	-	-	-	-	-	-	-
Stage 1	478	506	-	489	516	-	-	-	-	-	-	-
Stage 2	701	516	-	694	505	-	-	-	-	-	-	-

Approach	EB		WB		NB			SB		
HCM Control Delay, s	15.2		12.2		0			0		
HCM LOS	C		B							

Minor Lane/Major Mvmt	NBL	NBT	NBR	EBLn1	WBLn1	SBL	SBT	SBR
Capacity (veh/h)	1004	-	-	378	510	1018	-	-
HCM Lane V/C Ratio	-	-	-	0.07	0.017	0.001	-	-
HCM Control Delay (s)	0	-	-	15.2	12.2	8.5	-	-
HCM Lane LOS	A	-	-	C	B	A	-	-
HCM 95th %tile Q(veh)	0	-	-	0.2	0.1	0	-	-

Intersection						
Int Delay, s/veh	1.6					
Movement	WBL	WBR	NBT	NBR	SBL	SBT
Lane Configurations	↔		↑↓		↔	↑↑
Traffic Vol, veh/h	59	23	491	42	20	507
Future Vol, veh/h	59	23	491	42	20	507
Conflicting Peds, #/hr	0	0	0	0	0	0
Sign Control	Stop	Stop	Free	Free	Free	Free
RT Channelized	-	None	-	None	-	None
Storage Length	0	-	-	-	140	-
Veh in Median Storage, #	0	-	0	-	-	0
Grade, %	0	-	0	-	-	0
Peak Hour Factor	91	91	91	91	91	91
Heavy Vehicles, %	2	2	2	2	2	2
Mvmt Flow	65	25	540	46	22	557

Major/Minor	Minor1	Major1	Major2			
Conflicting Flow All	886	293	0	0	586	0
Stage 1	563	-	-	-	-	-
Stage 2	323	-	-	-	-	-
Critical Hdwy	6.84	6.94	-	-	4.14	-
Critical Hdwy Stg 1	5.84	-	-	-	-	-
Critical Hdwy Stg 2	5.84	-	-	-	-	-
Follow-up Hdwy	3.52	3.32	-	-	2.22	-
Pot Cap-1 Maneuver	284	703	-	-	985	-
Stage 1	534	-	-	-	-	-
Stage 2	706	-	-	-	-	-
Platoon blocked, %			-	-		
Mov Cap-1 Maneuver	278	703	-	-	985	-
Mov Cap-2 Maneuver	278	-	-	-	-	-
Stage 1	534	-	-	-	-	-
Stage 2	690	-	-	-	-	-

Approach	WB	NB	SB
HCM Control Delay, s	19.7	0	0.3
HCM LOS	C		

Minor Lane/Major Mvmt	NBT	NBRWBLn1	SBL	SBT
Capacity (veh/h)	-	-	335	985
HCM Lane V/C Ratio	-	-	0.269	0.022
HCM Control Delay (s)	-	-	19.7	8.7
HCM Lane LOS	-	-	C	A
HCM 95th %tile Q(veh)	-	-	1.1	0.1

Heritage at Dalia Ranch
4: Imperial Ave & Neckel Rd

Opening Year 2024
Timing Plan: AM PEAK

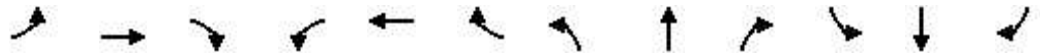

Movement	EBL	EBT	EBR	WBL	WBT	WBR	NBL	NBT	NBR	SBL	SBT	SBR
Lane Configurations		↕			↕		↕	↕↔		↕	↕↔	
Traffic Volume (veh/h)	34	44	13	144	65	56	8	448	66	15	518	31
Future Volume (veh/h)	34	44	13	144	65	56	8	448	66	15	518	31
Initial Q (Qb), veh	0	0	0	0	0	0	0	0	0	0	0	0
Ped-Bike Adj(A_pbT)	1.00		1.00	1.00		1.00	1.00		1.00	1.00		1.00
Parking Bus, Adj	1.00	1.00	1.00	1.00	1.00	1.00	1.00	1.00	1.00	1.00	1.00	1.00
Work Zone On Approach		No			No			No			No	
Adj Sat Flow, veh/h/ln	1870	1870	1870	1870	1870	1870	1870	1870	1870	1870	1870	1870
Adj Flow Rate, veh/h	37	48	14	158	71	62	9	492	73	16	569	34
Peak Hour Factor	0.91	0.91	0.91	0.91	0.91	0.91	0.91	0.91	0.91	0.91	0.91	0.91
Percent Heavy Veh, %	2	2	2	2	2	2	2	2	2	2	2	2
Cap, veh/h	52	68	20	208	93	82	21	758	112	36	860	51
Arrive On Green	0.08	0.08	0.08	0.22	0.22	0.22	0.01	0.24	0.24	0.02	0.25	0.25
Sat Flow, veh/h	669	869	253	953	428	374	1781	3106	459	1781	3407	203
Grp Volume(v), veh/h	99	0	0	291	0	0	9	281	284	16	296	307
Grp Sat Flow(s),veh/h/ln	1791	0	0	1755	0	0	1781	1777	1788	1781	1777	1834
Q Serve(g_s), s	2.5	0.0	0.0	7.1	0.0	0.0	0.2	6.5	6.5	0.4	6.8	6.8
Cycle Q Clear(g_c), s	2.5	0.0	0.0	7.1	0.0	0.0	0.2	6.5	6.5	0.4	6.8	6.8
Prop In Lane	0.37		0.14	0.54		0.21	1.00		0.26	1.00		0.11
Lane Grp Cap(c), veh/h	140	0	0	383	0	0	21	434	436	36	449	463
V/C Ratio(X)	0.70	0.00	0.00	0.76	0.00	0.00	0.43	0.65	0.65	0.45	0.66	0.66
Avail Cap(c_a), veh/h	708	0	0	694	0	0	196	741	746	196	741	765
HCM Platoon Ratio	1.00	1.00	1.00	1.00	1.00	1.00	1.00	1.00	1.00	1.00	1.00	1.00
Upstream Filter(l)	1.00	0.00	0.00	1.00	0.00	0.00	1.00	1.00	1.00	1.00	1.00	1.00
Uniform Delay (d), s/veh	20.5	0.0	0.0	16.7	0.0	0.0	22.3	15.4	15.5	22.1	15.3	15.3
Incr Delay (d2), s/veh	6.3	0.0	0.0	3.1	0.0	0.0	13.1	1.6	1.7	8.5	1.7	1.6
Initial Q Delay(d3),s/veh	0.0	0.0	0.0	0.0	0.0	0.0	0.0	0.0	0.0	0.0	0.0	0.0
%ile BackOfQ(50%),veh/ln	1.2	0.0	0.0	2.8	0.0	0.0	0.2	2.4	2.5	0.2	2.5	2.6
Unsig. Movement Delay, s/veh												
LnGrp Delay(d),s/veh	26.8	0.0	0.0	19.8	0.0	0.0	35.5	17.1	17.1	30.5	16.9	16.9
LnGrp LOS	C	A	A	B	A	A	D	B	B	C	B	B
Approach Vol, veh/h		99			291			574				619
Approach Delay, s/veh		26.8			19.8			17.4				17.3
Approach LOS		C			B			B				B
Timer - Assigned Phs	1	2		4	5	6		8				
Phs Duration (G+Y+Rc), s	5.9	16.1		8.6	5.5	16.5		14.9				
Change Period (Y+Rc), s	5.0	5.0		5.0	5.0	5.0		5.0				
Max Green Setting (Gmax), s	5.0	19.0		18.0	5.0	19.0		18.0				
Max Q Clear Time (g_c+I1), s	2.4	8.5		4.5	2.2	8.8		9.1				
Green Ext Time (p_c), s	0.0	2.5		0.3	0.0	2.7		1.1				
Intersection Summary												
HCM 6th Ctrl Delay				18.4								
HCM 6th LOS				B								

Intersection												
Int Delay, s/veh	7.7											
Movement	EBL	EBT	EBR	WBL	WBT	WBR	NBL	NBT	NBR	SBL	SBT	SBR
Lane Configurations		↕			↕			↕			↕	
Traffic Vol, veh/h	4	42	23	60	45	0	7	6	43	1	2	1
Future Vol, veh/h	4	42	23	60	45	0	7	6	43	1	2	1
Conflicting Peds, #/hr	0	0	0	0	0	0	0	0	0	0	0	0
Sign Control	Stop	Stop	Stop	Stop	Stop	Stop	Free	Free	Free	Free	Free	Free
RT Channelized	-	-	None	-	-	None	-	-	None	-	-	None
Storage Length	-	-	-	-	-	-	-	-	-	-	-	-
Veh in Median Storage, #	-	0	-	-	0	-	-	0	-	-	0	-
Grade, %	-	0	-	-	0	-	-	0	-	-	0	-
Peak Hour Factor	79	79	79	79	79	79	79	79	79	79	79	79
Heavy Vehicles, %	2	2	2	2	2	2	2	2	2	2	2	2
Mvmt Flow	5	53	29	76	57	0	9	8	54	1	3	1

Major/Minor	Minor2		Minor1		Major1			Major2				
Conflicting Flow All	88	86	4	100	59	35	4	0	0	62	0	0
Stage 1	6	6	-	53	53	-	-	-	-	-	-	-
Stage 2	82	80	-	47	6	-	-	-	-	-	-	-
Critical Hdwy	7.12	6.52	6.22	7.12	6.52	6.22	4.12	-	-	4.12	-	-
Critical Hdwy Stg 1	6.12	5.52	-	6.12	5.52	-	-	-	-	-	-	-
Critical Hdwy Stg 2	6.12	5.52	-	6.12	5.52	-	-	-	-	-	-	-
Follow-up Hdwy	3.518	4.018	3.318	3.518	4.018	3.318	2.218	-	-	2.218	-	-
Pot Cap-1 Maneuver	897	804	1080	881	832	1038	1618	-	-	1541	-	-
Stage 1	1016	891	-	960	851	-	-	-	-	-	-	-
Stage 2	926	828	-	967	891	-	-	-	-	-	-	-
Platoon blocked, %								-	-	-	-	-
Mov Cap-1 Maneuver	845	798	1080	810	826	1038	1618	-	-	1541	-	-
Mov Cap-2 Maneuver	845	798	-	810	826	-	-	-	-	-	-	-
Stage 1	1010	890	-	954	846	-	-	-	-	-	-	-
Stage 2	858	823	-	884	890	-	-	-	-	-	-	-

Approach	EB		WB		NB		SB	
HCM Control Delay, s	9.6		10.3		0.9		1.8	
HCM LOS	A		B					

Minor Lane/Major Mvmt	NBL	NBT	NBR	EBLn1	WBLn1	SBL	SBT	SBR
Capacity (veh/h)	1618	-	-	877	817	1541	-	-
HCM Lane V/C Ratio	0.005	-	-	0.1	0.163	0.001	-	-
HCM Control Delay (s)	7.2	0	-	9.6	10.3	7.3	0	-
HCM Lane LOS	A	A	-	A	B	A	A	-
HCM 95th %tile Q(veh)	0	-	-	0.3	0.6	0	-	-

Heritage at Dalia Ranch
6: Imperial Ave & Worthington Rd/Barioni Blvd

Opening Year 2024
Timing Plan: AM PEAK

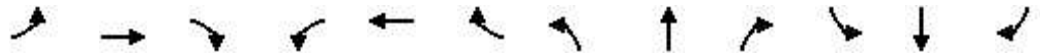

Movement	EBL	EBT	EBR	WBL	WBT	WBR	NBL	NBT	NBR	SBL	SBT	SBR
Lane Configurations		↕	↗		↕	↗	↗	↕↗		↗	↕↗	
Traffic Volume (veh/h)	71	138	215	55	133	78	94	471	51	40	639	56
Future Volume (veh/h)	71	138	215	55	133	78	94	471	51	40	639	56
Initial Q (Qb), veh	0	0	0	0	0	0	0	0	0	0	0	0
Ped-Bike Adj(A_pbT)	1.00		1.00	1.00		1.00	1.00		1.00	1.00		1.00
Parking Bus, Adj	1.00	1.00	1.00	1.00	1.00	1.00	1.00	1.00	1.00	1.00	1.00	1.00
Work Zone On Approach		No			No			No			No	
Adj Sat Flow, veh/h/ln	1870	1870	1870	1870	1870	1870	1870	1870	1870	1870	1870	1870
Adj Flow Rate, veh/h	80	155	242	62	149	88	106	529	57	45	718	63
Peak Hour Factor	0.89	0.89	0.89	0.89	0.89	0.89	0.89	0.89	0.89	0.89	0.89	0.89
Percent Heavy Veh, %	2	2	2	2	2	2	2	2	2	2	2	2
Cap, veh/h	123	237	310	84	201	245	136	958	103	76	868	76
Arrive On Green	0.20	0.20	0.20	0.15	0.15	0.15	0.08	0.30	0.30	0.04	0.26	0.26
Sat Flow, veh/h	626	1213	1585	542	1302	1585	1781	3237	348	1781	3305	290
Grp Volume(v), veh/h	235	0	242	211	0	88	106	290	296	45	386	395
Grp Sat Flow(s),veh/h/ln	1839	0	1585	1843	0	1585	1781	1777	1808	1781	1777	1818
Q Serve(g_s), s	7.6	0.0	9.3	7.0	0.0	3.2	3.8	8.8	8.9	1.6	13.2	13.2
Cycle Q Clear(g_c), s	7.6	0.0	9.3	7.0	0.0	3.2	3.8	8.8	8.9	1.6	13.2	13.2
Prop In Lane	0.34		1.00	0.29		1.00	1.00		0.19	1.00		0.16
Lane Grp Cap(c), veh/h	360	0	310	285	0	245	136	526	535	76	467	478
V/C Ratio(X)	0.65	0.00	0.78	0.74	0.00	0.36	0.78	0.55	0.55	0.59	0.83	0.83
Avail Cap(c_a), veh/h	515	0	444	516	0	444	138	526	535	138	525	537
HCM Platoon Ratio	1.00	1.00	1.00	1.00	1.00	1.00	1.00	1.00	1.00	1.00	1.00	1.00
Upstream Filter(I)	1.00	0.00	1.00	1.00	0.00	1.00	1.00	1.00	1.00	1.00	1.00	1.00
Uniform Delay (d), s/veh	23.9	0.0	24.6	26.0	0.0	24.3	29.2	19.1	19.1	30.2	22.3	22.3
Incr Delay (d2), s/veh	2.0	0.0	5.6	3.8	0.0	0.9	24.2	1.2	1.3	7.0	9.6	9.4
Initial Q Delay(d3),s/veh	0.0	0.0	0.0	0.0	0.0	0.0	0.0	0.0	0.0	0.0	0.0	0.0
%ile BackOfQ(50%),veh/ln	3.3	0.0	3.8	3.2	0.0	1.2	2.4	3.5	3.6	0.8	6.3	6.5
Unsig. Movement Delay, s/veh												
LnGrp Delay(d),s/veh	25.9	0.0	30.2	29.7	0.0	25.2	53.4	20.3	20.3	37.2	31.9	31.8
LnGrp LOS	C	A	C	C	A	C	D	C	C	D	C	C
Approach Vol, veh/h		477			299			692				826
Approach Delay, s/veh		28.0			28.4			25.4				32.1
Approach LOS		C			C			C				C
Timer - Assigned Phs	1	2		4	5	6		8				
Phs Duration (G+Y+Rc), s	7.8	24.0		17.6	9.9	21.9		14.9				
Change Period (Y+Rc), s	5.0	5.0		5.0	5.0	5.0		5.0				
Max Green Setting (Gmax), s	5.0	19.0		18.0	5.0	19.0		18.0				
Max Q Clear Time (g_c+I1), s	3.6	10.9		11.3	5.8	15.2		9.0				
Green Ext Time (p_c), s	0.0	2.2		1.3	0.0	1.7		1.0				

Intersection Summary

HCM 6th Ctrl Delay	28.8
HCM 6th LOS	C

Intersection

Intersection Delay, s/veh 19.9

Intersection LOS C

Movement	EBL	EBT	EBR	WBL	WBT	WBR	NBL	NBT	NBR	SBL	SBT	SBR
Lane Configurations		↔	↔		↔	↔		↔			↔	
Traffic Vol, veh/h	62	395	121	11	305	78	0	0	1	107	31	65
Future Vol, veh/h	62	395	121	11	305	78	0	0	1	107	31	65
Peak Hour Factor	0.92	0.92	0.92	0.92	0.92	0.92	0.92	0.92	0.92	0.92	0.92	0.92
Heavy Vehicles, %	2	2	2	2	2	2	2	2	2	2	2	2
Mvmt Flow	67	429	132	12	332	85	0	0	1	116	34	71
Number of Lanes	0	1	1	0	1	1	0	1	0	0	1	0

Approach	EB	WB	NB	SB
Opposing Approach	WB	EB	SB	NB
Opposing Lanes	2	2	1	1
Conflicting Approach Left	SB	NB	EB	WB
Conflicting Lanes Left	1	1	2	2
Conflicting Approach Right	NB	SB	WB	EB
Conflicting Lanes Right	1	1	2	2
HCM Control Delay	25.3	15.4	9.6	13.3
HCM LOS	D	C	A	B

Lane	NBLn1	EBLn1	EBLn2	WBLn1	WBLn2	SBLn1
Vol Left, %	0%	14%	0%	3%	0%	53%
Vol Thru, %	0%	86%	0%	97%	0%	15%
Vol Right, %	100%	0%	100%	0%	100%	32%
Sign Control	Stop	Stop	Stop	Stop	Stop	Stop
Traffic Vol by Lane	1	457	121	316	78	203
LT Vol	0	62	0	11	0	107
Through Vol	0	395	0	305	0	31
RT Vol	1	0	121	0	78	65
Lane Flow Rate	1	497	132	343	85	221
Geometry Grp	2	7	7	7	7	2
Degree of Util (X)	0.002	0.815	0.187	0.581	0.126	0.386
Departure Headway (Hd)	6.519	5.91	5.131	6.094	5.365	6.304
Convergence, Y/N	Yes	Yes	Yes	Yes	Yes	Yes
Cap	545	611	698	591	666	569
Service Time	4.607	3.651	2.872	3.84	3.111	4.356
HCM Lane V/C Ratio	0.002	0.813	0.189	0.58	0.128	0.388
HCM Control Delay	9.6	29.6	9.1	17	8.9	13.3
HCM Lane LOS	A	D	A	C	A	B
HCM 95th-tile Q	0	8.3	0.7	3.7	0.4	1.8

Heritage at Dalia Ranch
8: Imperial Ave & Aten Rd

Opening Year 2024
Timing Plan: AM PEAK



Movement	EBL	EBT	EBR	WBL	WBT	WBR	NBL	NBT	NBR	SBL	SBT	SBR
Lane Configurations												
Traffic Volume (veh/h)	189	342	64	132	303	143	62	348	68	144	680	381
Future Volume (veh/h)	189	342	64	132	303	143	62	348	68	144	680	381
Initial Q (Qb), veh	0	0	0	0	0	0	0	0	0	0	0	0
Ped-Bike Adj(A_pbT)	1.00		1.00	1.00		1.00	1.00		1.00	1.00		1.00
Parking Bus, Adj	1.00	1.00	1.00	1.00	1.00	1.00	1.00	1.00	1.00	1.00	1.00	1.00
Work Zone On Approach		No		No		No		No		No		No
Adj Sat Flow, veh/h/ln	1870	1870	1870	1870	1870	1870	1870	1870	1870	1870	1870	1870
Adj Flow Rate, veh/h	220	398	74	153	352	166	72	405	79	167	791	443
Peak Hour Factor	0.86	0.86	0.86	0.86	0.86	0.86	0.86	0.86	0.86	0.86	0.86	0.86
Percent Heavy Veh, %	2	2	2	2	2	2	2	2	2	2	2	2
Cap, veh/h	259	704	130	192	464	215	97	892	398	206	1110	495
Arrive On Green	0.15	0.23	0.23	0.11	0.20	0.20	0.05	0.25	0.25	0.12	0.31	0.31
Sat Flow, veh/h	1781	2995	552	1781	2358	1093	1781	3554	1585	1781	3554	1585
Grp Volume(v), veh/h	220	235	237	153	264	254	72	405	79	167	791	443
Grp Sat Flow(s),veh/h/ln	1781	1777	1771	1781	1777	1674	1781	1777	1585	1781	1777	1585
Q Serve(g_s), s	8.3	8.0	8.1	5.8	9.6	9.9	2.7	6.6	2.7	6.3	13.5	18.3
Cycle Q Clear(g_c), s	8.3	8.0	8.1	5.8	9.6	9.9	2.7	6.6	2.7	6.3	13.5	18.3
Prop In Lane	1.00		0.31	1.00		0.65	1.00		1.00	1.00		1.00
Lane Grp Cap(c), veh/h	259	417	416	192	350	330	97	892	398	206	1110	495
V/C Ratio(X)	0.85	0.56	0.57	0.80	0.75	0.77	0.74	0.45	0.20	0.81	0.71	0.90
Avail Cap(c_a), veh/h	259	491	490	233	465	438	130	983	438	207	1138	507
HCM Platoon Ratio	1.00	1.00	1.00	1.00	1.00	1.00	1.00	1.00	1.00	1.00	1.00	1.00
Upstream Filter(l)	1.00	1.00	1.00	1.00	1.00	1.00	1.00	1.00	1.00	1.00	1.00	1.00
Uniform Delay (d), s/veh	28.6	23.2	23.2	29.9	26.0	26.1	32.0	21.8	20.3	29.7	20.9	22.6
Incr Delay (d2), s/veh	22.4	1.2	1.2	14.8	4.8	6.0	14.5	0.4	0.2	20.9	2.1	18.0
Initial Q Delay(d3),s/veh	0.0	0.0	0.0	0.0	0.0	0.0	0.0	0.0	0.0	0.0	0.0	0.0
%ile BackOfQ(50%),veh/ln	5.0	3.3	3.4	3.2	4.3	4.3	1.5	2.6	1.0	3.8	5.5	8.8
Unsig. Movement Delay, s/veh												
LnGrp Delay(d),s/veh	51.0	24.4	24.5	44.7	30.9	32.1	46.5	22.1	20.5	50.6	23.0	40.6
LnGrp LOS	D	C	C	D	C	C	D	C	C	D	C	D
Approach Vol, veh/h		692			671			556			1401	
Approach Delay, s/veh		32.9			34.5			25.1			31.8	
Approach LOS		C			C			C			C	
Timer - Assigned Phs	1	2	3	4	5	6	7	8				
Phs Duration (G+Y+Rc), s	12.9	22.2	12.4	21.1	8.7	26.5	15.0	18.5				
Change Period (Y+Rc), s	5.0	5.0	5.0	5.0	5.0	5.0	5.0	5.0				
Max Green Setting (Gmax), s	19.0	19.0	9.0	19.0	5.0	22.0	10.0	18.0				
Max Q Clear Time (g_c+1/3), s	10.3	8.6	7.8	10.1	4.7	20.3	10.3	11.9				
Green Ext Time (p_c), s	0.0	2.1	0.0	1.9	0.0	1.1	0.0	1.6				
Intersection Summary												
HCM 6th Ctrl Delay											31.4	
HCM 6th LOS											C	

Intersection												
Int Delay, s/veh	0.3											
Movement	EBL	EBT	EBR	WBL	WBT	WBR	NBL	NBT	NBR	SBL	SBT	SBR
Lane Configurations		↕			↕		↕	↕		↕	↕	
Traffic Vol, veh/h	6	4	0	7	0	5	1	569	7	6	586	18
Future Vol, veh/h	6	4	0	7	0	5	1	569	7	6	586	18
Conflicting Peds, #/hr	0	0	0	0	0	0	0	0	0	0	0	0
Sign Control	Stop	Stop	Stop	Stop	Stop	Stop	Free	Free	Free	Free	Free	Free
RT Channelized	-	-	None	-	-	None	-	-	None	-	-	None
Storage Length	-	-	-	-	-	-	50	-	-	50	-	-
Veh in Median Storage, #	-	1	-	-	1	-	-	0	-	-	0	-
Grade, %	-	0	-	-	0	-	-	0	-	-	0	-
Peak Hour Factor	92	92	92	92	92	92	92	92	92	92	92	92
Heavy Vehicles, %	2	2	2	2	2	2	2	2	2	2	2	2
Mvmt Flow	7	4	0	8	0	5	1	618	8	7	637	20

Major/Minor	Minor2		Minor1		Major1			Major2				
Conflicting Flow All	972	1289	329	959	1295	313	657	0	0	626	0	0
Stage 1	661	661	-	624	624	-	-	-	-	-	-	-
Stage 2	311	628	-	335	671	-	-	-	-	-	-	-
Critical Hdwy	7.54	6.54	6.94	7.54	6.54	6.94	4.14	-	-	4.14	-	-
Critical Hdwy Stg 1	6.54	5.54	-	6.54	5.54	-	-	-	-	-	-	-
Critical Hdwy Stg 2	6.54	5.54	-	6.54	5.54	-	-	-	-	-	-	-
Follow-up Hdwy	3.52	4.02	3.32	3.52	4.02	3.32	2.22	-	-	2.22	-	-
Pot Cap-1 Maneuver	207	162	667	211	161	683	926	-	-	952	-	-
Stage 1	418	458	-	440	476	-	-	-	-	-	-	-
Stage 2	674	474	-	653	453	-	-	-	-	-	-	-
Platoon blocked, %								-	-	-	-	-
Mov Cap-1 Maneuver	204	161	667	207	160	683	926	-	-	952	-	-
Mov Cap-2 Maneuver	319	284	-	327	284	-	-	-	-	-	-	-
Stage 1	418	455	-	440	476	-	-	-	-	-	-	-
Stage 2	668	474	-	642	450	-	-	-	-	-	-	-

Approach	EB		WB		NB		SB	
HCM Control Delay, s	17.3		13.9		0		0.1	
HCM LOS	C		B					

Minor Lane/Major Mvmt	NBL	NBT	NBR	EBLn1	WBLn1	SBL	SBT	SBR
Capacity (veh/h)	926	-	-	304	418	952	-	-
HCM Lane V/C Ratio	0.001	-	-	0.036	0.031	0.007	-	-
HCM Control Delay (s)	8.9	-	-	17.3	13.9	8.8	-	-
HCM Lane LOS	A	-	-	C	B	A	-	-
HCM 95th %tile Q(veh)	0	-	-	0.1	0.1	0	-	-

Intersection						
Int Delay, s/veh	0.7					
Movement	WBL	WBR	NBT	NBR	SBL	SBT
Lane Configurations	↔		↑↓		↔	↑↑
Traffic Vol, veh/h	20	10	570	30	30	549
Future Vol, veh/h	20	10	570	30	30	549
Conflicting Peds, #/hr	0	0	0	0	0	0
Sign Control	Stop	Stop	Free	Free	Free	Free
RT Channelized	-	None	-	None	-	None
Storage Length	0	-	-	-	140	-
Veh in Median Storage, #	0	-	0	-	-	0
Grade, %	0	-	0	-	-	0
Peak Hour Factor	91	91	91	91	91	91
Heavy Vehicles, %	2	2	2	2	2	2
Mvmt Flow	22	11	626	33	33	603

Major/Minor	Minor1	Major1	Major2		
Conflicting Flow All	1011	330	0	0	659
Stage 1	643	-	-	-	-
Stage 2	368	-	-	-	-
Critical Hdwy	6.84	6.94	-	-	4.14
Critical Hdwy Stg 1	5.84	-	-	-	-
Critical Hdwy Stg 2	5.84	-	-	-	-
Follow-up Hdwy	3.52	3.32	-	-	2.22
Pot Cap-1 Maneuver	236	666	-	-	925
Stage 1	485	-	-	-	-
Stage 2	670	-	-	-	-
Platoon blocked, %			-	-	-
Mov Cap-1 Maneuver	228	666	-	-	925
Mov Cap-2 Maneuver	228	-	-	-	-
Stage 1	485	-	-	-	-
Stage 2	646	-	-	-	-

Approach	WB	NB	SB
HCM Control Delay, s	18.9	0	0.5
HCM LOS	C		

Minor Lane/Major Mvmt	NBT	NBRWBLn1	SBL	SBT
Capacity (veh/h)	-	-	292	925
HCM Lane V/C Ratio	-	-	0.113	0.036
HCM Control Delay (s)	-	-	18.9	9
HCM Lane LOS	-	-	C	A
HCM 95th %tile Q(veh)	-	-	0.4	0.1

Intersection												
Int Delay, s/veh	7.7											
Movement	EBL	EBT	EBR	WBL	WBT	WBR	NBL	NBT	NBR	SBL	SBT	SBR
Lane Configurations		↕			↕			↕			↕	
Traffic Vol, veh/h	2	39	8	23	45	1	5	6	10	0	5	7
Future Vol, veh/h	2	39	8	23	45	1	5	6	10	0	5	7
Conflicting Peds, #/hr	0	0	0	0	0	0	0	0	0	0	0	0
Sign Control	Stop	Stop	Stop	Stop	Stop	Stop	Free	Free	Free	Free	Free	Free
RT Channelized	-	-	None	-	-	None	-	-	None	-	-	None
Storage Length	-	-	-	-	-	-	-	-	-	-	-	-
Veh in Median Storage, #	-	0	-	-	0	-	-	0	-	-	0	-
Grade, %	-	0	-	-	0	-	-	0	-	-	0	-
Peak Hour Factor	79	79	79	79	79	79	79	79	79	79	79	79
Heavy Vehicles, %	2	2	2	2	2	2	2	2	2	2	2	2
Mvmt Flow	3	49	10	29	57	1	6	8	13	0	6	9

Major/Minor	Minor2		Minor1		Major1		Major2					
Conflicting Flow All	67	44	11	67	42	15	15	0	0	21	0	0
Stage 1	11	11	-	27	27	-	-	-	-	-	-	-
Stage 2	56	33	-	40	15	-	-	-	-	-	-	-
Critical Hdwy	7.12	6.52	6.22	7.12	6.52	6.22	4.12	-	-	4.12	-	-
Critical Hdwy Stg 1	6.12	5.52	-	6.12	5.52	-	-	-	-	-	-	-
Critical Hdwy Stg 2	6.12	5.52	-	6.12	5.52	-	-	-	-	-	-	-
Follow-up Hdwy	3.518	4.018	3.318	3.518	4.018	3.318	2.218	-	-	2.218	-	-
Pot Cap-1 Maneuver	926	848	1070	926	850	1065	1603	-	-	1595	-	-
Stage 1	1010	886	-	990	873	-	-	-	-	-	-	-
Stage 2	956	868	-	975	883	-	-	-	-	-	-	-
Platoon blocked, %								-	-	-	-	-
Mov Cap-1 Maneuver	875	845	1070	873	847	1065	1603	-	-	1595	-	-
Mov Cap-2 Maneuver	875	845	-	873	847	-	-	-	-	-	-	-
Stage 1	1006	886	-	986	870	-	-	-	-	-	-	-
Stage 2	889	865	-	912	883	-	-	-	-	-	-	-

Approach	EB		WB		NB		SB	
HCM Control Delay, s	9.4		9.7		1.7		0	
HCM LOS	A		A					

Minor Lane/Major Mvmt	NBL	NBT	NBR	EBLn1	WBLn1	SBL	SBT	SBR
Capacity (veh/h)	1603	-	-	876	858	1595	-	-
HCM Lane V/C Ratio	0.004	-	-	0.071	0.102	-	-	-
HCM Control Delay (s)	7.3	0	-	9.4	9.7	0	-	-
HCM Lane LOS	A	A	-	A	A	A	-	-
HCM 95th %tile Q(veh)	0	-	-	0.2	0.3	0	-	-

Intersection												
Intersection Delay, s/veh	10.6											
Intersection LOS	B											

Movement	EBL	EBT	EBR	WBL	WBT	WBR	NBL	NBT	NBR	SBL	SBT	SBR
Lane Configurations		↔	↔		↔	↔		↔			↔	
Traffic Vol, veh/h	26	190	33	27	218	34	1	0	0	38	5	24
Future Vol, veh/h	26	190	33	27	218	34	1	0	0	38	5	24
Peak Hour Factor	0.80	0.80	0.80	0.80	0.80	0.80	0.80	0.80	0.80	0.80	0.80	0.80
Heavy Vehicles, %	2	2	2	2	2	2	2	2	2	2	2	2
Mvmt Flow	33	238	41	34	273	43	1	0	0	48	6	30
Number of Lanes	0	1	1	0	1	1	0	1	0	0	1	0

Approach	EB	WB	NB	SB
Opposing Approach	WB	EB	SB	NB
Opposing Lanes	2	2	1	1
Conflicting Approach Left	SB	NB	EB	WB
Conflicting Lanes Left	1	1	2	2
Conflicting Approach Right	NB	SB	WB	EB
Conflicting Lanes Right	1	1	2	2
HCM Control Delay	10.5	11.1	8.9	9.2
HCM LOS	B	B	A	A

Lane	NBLn1	EBLn1	EBLn2	WBLn1	WBLn2	SBLn1
Vol Left, %	100%	12%	0%	11%	0%	57%
Vol Thru, %	0%	88%	0%	89%	0%	7%
Vol Right, %	0%	0%	100%	0%	100%	36%
Sign Control	Stop	Stop	Stop	Stop	Stop	Stop
Traffic Vol by Lane	1	216	33	245	34	67
LT Vol	1	26	0	27	0	38
Through Vol	0	190	0	218	0	5
RT Vol	0	0	33	0	34	24
Lane Flow Rate	1	270	41	306	42	84
Geometry Grp	2	7	7	7	7	2
Degree of Util (X)	0.002	0.384	0.05	0.432	0.051	0.124
Departure Headway (Hd)	5.802	5.117	4.352	5.081	4.322	5.342
Convergence, Y/N	Yes	Yes	Yes	Yes	Yes	Yes
Cap	613	702	821	707	827	669
Service Time	3.87	2.853	2.089	2.816	2.057	3.391
HCM Lane V/C Ratio	0.002	0.385	0.05	0.433	0.051	0.126
HCM Control Delay	8.9	11	7.3	11.6	7.3	9.2
HCM Lane LOS	A	B	A	B	A	A
HCM 95th-tile Q	0	1.8	0.2	2.2	0.2	0.4

Heritage at Dalia Ranch
1: SR-86 & Keystone Rd

Opening Year 2024 + P1-2 Proj
Timing Plan: AM PEAK

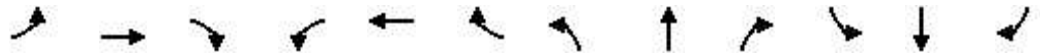

Movement	EBL	EBT	EBR	WBL	WBT	WBR	NBL	NBT	NBR	SBL	SBT	SBR
Lane Configurations		↕			↕		↕	↕↕	↕	↕	↕↕	↕
Traffic Volume (veh/h)	33	33	11	19	24	43	19	475	50	46	529	38
Future Volume (veh/h)	33	33	11	19	24	43	19	475	50	46	529	38
Initial Q (Qb), veh	0	0	0	0	0	0	0	0	0	0	0	0
Ped-Bike Adj(A_pbT)	1.00		1.00	1.00		1.00	1.00		1.00	1.00		1.00
Parking Bus, Adj	1.00	1.00	1.00	1.00	1.00	1.00	1.00	1.00	1.00	1.00	1.00	1.00
Work Zone On Approach		No			No			No			No	
Adj Sat Flow, veh/h/ln	1870	1870	1870	1870	1870	1870	1870	1870	1870	1870	1870	1870
Adj Flow Rate, veh/h	37	37	12	21	27	48	21	528	56	51	588	42
Peak Hour Factor	0.90	0.90	0.90	0.90	0.90	0.90	0.90	0.90	0.90	0.90	0.90	0.90
Percent Heavy Veh, %	2	2	2	2	2	2	2	2	2	2	2	2
Cap, veh/h	256	110	31	187	73	109	48	1046	467	103	1157	516
Arrive On Green	0.13	0.13	0.13	0.13	0.13	0.13	0.03	0.29	0.29	0.06	0.33	0.33
Sat Flow, veh/h	597	832	232	272	551	823	1781	3554	1585	1781	3554	1585
Grp Volume(v), veh/h	86	0	0	96	0	0	21	528	56	51	588	42
Grp Sat Flow(s),veh/h/ln	1661	0	0	1646	0	0	1781	1777	1585	1781	1777	1585
Q Serve(g_s), s	0.0	0.0	0.0	0.2	0.0	0.0	0.3	3.6	0.8	0.8	3.9	0.5
Cycle Q Clear(g_c), s	1.2	0.0	0.0	1.5	0.0	0.0	0.3	3.6	0.8	0.8	3.9	0.5
Prop In Lane	0.43		0.14	0.22		0.50	1.00		1.00	1.00		1.00
Lane Grp Cap(c), veh/h	397	0	0	368	0	0	48	1046	467	103	1157	516
V/C Ratio(X)	0.22	0.00	0.00	0.26	0.00	0.00	0.44	0.50	0.12	0.49	0.51	0.08
Avail Cap(c_a), veh/h	1152	0	0	1143	0	0	306	2197	980	306	2197	980
HCM Platoon Ratio	1.00	1.00	1.00	1.00	1.00	1.00	1.00	1.00	1.00	1.00	1.00	1.00
Upstream Filter(l)	1.00	0.00	0.00	1.00	0.00	0.00	1.00	1.00	1.00	1.00	1.00	1.00
Uniform Delay (d), s/veh	11.5	0.0	0.0	11.6	0.0	0.0	14.0	8.5	7.5	13.3	7.9	6.8
Incr Delay (d2), s/veh	0.3	0.0	0.0	0.4	0.0	0.0	6.2	0.4	0.1	3.6	0.3	0.1
Initial Q Delay(d3),s/veh	0.0	0.0	0.0	0.0	0.0	0.0	0.0	0.0	0.0	0.0	0.0	0.0
%ile BackOfQ(50%),veh/ln	0.4	0.0	0.0	0.5	0.0	0.0	0.2	0.9	0.2	0.4	1.0	0.1
Unsig. Movement Delay, s/veh												
LnGrp Delay(d),s/veh	11.8	0.0	0.0	12.0	0.0	0.0	20.2	8.9	7.6	16.9	8.3	6.9
LnGrp LOS	B	A	A	B	A	A	C	A	A	B	A	A
Approach Vol, veh/h		86			96			605			681	
Approach Delay, s/veh		11.8			12.0			9.2			8.8	
Approach LOS		B			B			A			A	
Timer - Assigned Phs	1	2		4	5	6		8				
Phs Duration (G+Y+Rc), s	6.7	13.6		8.9	5.8	14.5		8.9				
Change Period (Y+Rc), s	5.0	5.0		5.0	5.0	5.0		5.0				
Max Green Setting (Gmax), s	5.0	18.0		18.0	5.0	18.0		18.0				
Max Q Clear Time (g_c+I1), s	2.8	5.6		3.2	2.3	5.9		3.5				
Green Ext Time (p_c), s	0.0	3.0		0.3	0.0	3.3		0.4				
Intersection Summary												
HCM 6th Ctrl Delay				9.3								
HCM 6th LOS				A								

Intersection												
Int Delay, s/veh	0.4											
Movement	EBL	EBT	EBR	WBL	WBT	WBR	NBL	NBT	NBR	SBL	SBT	SBR
Lane Configurations		↕			↕		↕	↕		↕	↕	
Traffic Vol, veh/h	20	3	2	1	2	5	0	543	1	1	534	7
Future Vol, veh/h	20	3	2	1	2	5	0	543	1	1	534	7
Conflicting Peds, #/hr	0	0	0	0	0	0	0	0	0	0	0	0
Sign Control	Stop	Stop	Stop	Stop	Stop	Stop	Free	Free	Free	Free	Free	Free
RT Channelized	-	-	None	-	-	None	-	-	None	-	-	None
Storage Length	-	-	-	-	-	-	50	-	-	50	-	-
Veh in Median Storage, #	-	1	-	-	1	-	-	0	-	-	0	-
Grade, %	-	0	-	-	0	-	-	0	-	-	0	-
Peak Hour Factor	94	94	94	94	94	94	94	94	94	94	94	94
Heavy Vehicles, %	2	2	2	2	2	2	2	2	2	2	2	2
Mvmt Flow	21	3	2	1	2	5	0	578	1	1	568	7

Major/Minor	Minor2		Minor1		Major1			Major2				
Conflicting Flow All	864	1153	288	867	1156	290	575	0	0	579	0	0
Stage 1	574	574	-	579	579	-	-	-	-	-	-	-
Stage 2	290	579	-	288	577	-	-	-	-	-	-	-
Critical Hdwy	7.54	6.54	6.94	7.54	6.54	6.94	4.14	-	-	4.14	-	-
Critical Hdwy Stg 1	6.54	5.54	-	6.54	5.54	-	-	-	-	-	-	-
Critical Hdwy Stg 2	6.54	5.54	-	6.54	5.54	-	-	-	-	-	-	-
Follow-up Hdwy	3.52	4.02	3.32	3.52	4.02	3.32	2.22	-	-	2.22	-	-
Pot Cap-1 Maneuver	248	196	709	247	195	707	994	-	-	991	-	-
Stage 1	471	501	-	468	499	-	-	-	-	-	-	-
Stage 2	694	499	-	695	500	-	-	-	-	-	-	-
Platoon blocked, %								-	-	-	-	-
Mov Cap-1 Maneuver	245	196	709	244	195	707	994	-	-	991	-	-
Mov Cap-2 Maneuver	360	317	-	359	317	-	-	-	-	-	-	-
Stage 1	471	500	-	468	499	-	-	-	-	-	-	-
Stage 2	686	499	-	688	500	-	-	-	-	-	-	-

Approach	EB		WB		NB		SB	
HCM Control Delay, s	15.5		12.4		0		0	
HCM LOS	C		B					

Minor Lane/Major Mvmt	NBL	NBT	NBR	EBLn1	WBLn1	SBL	SBT	SBR
Capacity (veh/h)	994	-	-	369	495	991	-	-
HCM Lane V/C Ratio	-	-	-	0.072	0.017	0.001	-	-
HCM Control Delay (s)	0	-	-	15.5	12.4	8.6	-	-
HCM Lane LOS	A	-	-	C	B	A	-	-
HCM 95th %tile Q(veh)	0	-	-	0.2	0.1	0	-	-

Intersection						
Int Delay, s/veh	1.6					
Movement	WBL	WBR	NBT	NBR	SBL	SBT
Lane Configurations	Y		↑↑		Y	↑↑
Traffic Vol, veh/h	59	23	521	42	20	517
Future Vol, veh/h	59	23	521	42	20	517
Conflicting Peds, #/hr	0	0	0	0	0	0
Sign Control	Stop	Stop	Free	Free	Free	Free
RT Channelized	-	None	-	None	-	None
Storage Length	0	-	-	-	140	-
Veh in Median Storage, #	0	-	0	-	-	0
Grade, %	0	-	0	-	-	0
Peak Hour Factor	91	91	91	91	91	91
Heavy Vehicles, %	2	2	2	2	2	2
Mvmt Flow	65	25	573	46	22	568

Major/Minor	Minor1	Major1	Major2		
Conflicting Flow All	924	310	0	0	619
Stage 1	596	-	-	-	-
Stage 2	328	-	-	-	-
Critical Hdwy	6.84	6.94	-	-	4.14
Critical Hdwy Stg 1	5.84	-	-	-	-
Critical Hdwy Stg 2	5.84	-	-	-	-
Follow-up Hdwy	3.52	3.32	-	-	2.22
Pot Cap-1 Maneuver	268	686	-	-	957
Stage 1	513	-	-	-	-
Stage 2	702	-	-	-	-
Platoon blocked, %			-	-	-
Mov Cap-1 Maneuver	262	686	-	-	957
Mov Cap-2 Maneuver	262	-	-	-	-
Stage 1	513	-	-	-	-
Stage 2	686	-	-	-	-

Approach	WB	NB	SB
HCM Control Delay, s	20.8	0	0.3
HCM LOS	C		

Minor Lane/Major Mvmt	NBT	NBRWBLn1	SBL	SBT
Capacity (veh/h)	-	-	317	957
HCM Lane V/C Ratio	-	-	0.284	0.023
HCM Control Delay (s)	-	-	20.8	8.8
HCM Lane LOS	-	-	C	A
HCM 95th %tile Q(veh)	-	-	1.1	0.1

Heritage at Dalia Ranch
4: Imperial Ave & Neckel Rd

Opening Year 2024 + P1-2 Proj
Timing Plan: AM PEAK

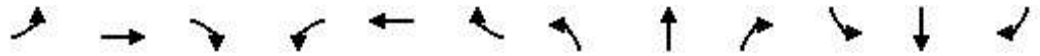

Movement	EBL	EBT	EBR	WBL	WBT	WBR	NBL	NBT	NBR	SBL	SBT	SBR
Lane Configurations		↕			↕		↕	↕↔		↕	↕↔	
Traffic Volume (veh/h)	64	44	117	144	65	56	44	448	66	15	518	41
Future Volume (veh/h)	64	44	117	144	65	56	44	448	66	15	518	41
Initial Q (Qb), veh	0	0	0	0	0	0	0	0	0	0	0	0
Ped-Bike Adj(A_pbT)	1.00		1.00	1.00		1.00	1.00		1.00	1.00		1.00
Parking Bus, Adj	1.00	1.00	1.00	1.00	1.00	1.00	1.00	1.00	1.00	1.00	1.00	1.00
Work Zone On Approach		No			No			No			No	
Adj Sat Flow, veh/h/ln	1870	1870	1870	1870	1870	1870	1870	1870	1870	1870	1870	1870
Adj Flow Rate, veh/h	70	48	129	158	71	62	48	492	73	16	569	45
Peak Hour Factor	0.91	0.91	0.91	0.91	0.91	0.91	0.91	0.91	0.91	0.91	0.91	0.91
Percent Heavy Veh, %	2	2	2	2	2	2	2	2	2	2	2	2
Cap, veh/h	88	60	162	195	88	77	82	796	118	35	767	61
Arrive On Green	0.18	0.18	0.18	0.20	0.20	0.20	0.05	0.26	0.26	0.02	0.23	0.23
Sat Flow, veh/h	478	328	881	953	428	374	1781	3106	459	1781	3336	263
Grp Volume(v), veh/h	247	0	0	291	0	0	48	281	284	16	303	311
Grp Sat Flow(s),veh/h/ln	1688	0	0	1755	0	0	1781	1777	1788	1781	1777	1823
Q Serve(g_s), s	8.3	0.0	0.0	9.4	0.0	0.0	1.6	8.3	8.4	0.5	9.4	9.5
Cycle Q Clear(g_c), s	8.3	0.0	0.0	9.4	0.0	0.0	1.6	8.3	8.4	0.5	9.4	9.5
Prop In Lane	0.28		0.52	0.54		0.21	1.00		0.26	1.00		0.14
Lane Grp Cap(c), veh/h	311	0	0	360	0	0	82	455	458	35	408	419
V/C Ratio(X)	0.79	0.00	0.00	0.81	0.00	0.00	0.59	0.62	0.62	0.46	0.74	0.74
Avail Cap(c_a), veh/h	509	0	0	529	0	0	149	565	569	149	565	580
HCM Platoon Ratio	1.00	1.00	1.00	1.00	1.00	1.00	1.00	1.00	1.00	1.00	1.00	1.00
Upstream Filter(l)	1.00	0.00	0.00	1.00	0.00	0.00	1.00	1.00	1.00	1.00	1.00	1.00
Uniform Delay (d), s/veh	23.3	0.0	0.0	22.6	0.0	0.0	27.9	19.6	19.6	29.0	21.3	21.4
Incr Delay (d2), s/veh	4.6	0.0	0.0	5.8	0.0	0.0	6.5	1.4	1.4	9.2	3.3	3.3
Initial Q Delay(d3),s/veh	0.0	0.0	0.0	0.0	0.0	0.0	0.0	0.0	0.0	0.0	0.0	0.0
%ile BackOfQ(50%),veh/ln	3.5	0.0	0.0	4.2	0.0	0.0	0.8	3.3	3.4	0.3	4.0	4.1
Unsig. Movement Delay, s/veh												
LnGrp Delay(d),s/veh	27.9	0.0	0.0	28.4	0.0	0.0	34.4	21.0	21.0	38.1	24.7	24.7
LnGrp LOS	C	A	A	C	A	A	C	C	C	D	C	C
Approach Vol, veh/h		247			291			613				630
Approach Delay, s/veh		27.9			28.4			22.0				25.0
Approach LOS		C			C			C				C
Timer - Assigned Phs	1	2		4	5	6		8				
Phs Duration (G+Y+Rc), s	6.2	20.3		16.0	7.7	18.7		17.2				
Change Period (Y+Rc), s	5.0	5.0		5.0	5.0	5.0		5.0				
Max Green Setting (Gmax), s	5.0	19.0		18.0	5.0	19.0		18.0				
Max Q Clear Time (g_c+I1), s	2.5	10.4		10.3	3.6	11.5		11.4				
Green Ext Time (p_c), s	0.0	2.2		0.8	0.0	2.2		0.9				
Intersection Summary												
HCM 6th Ctrl Delay				24.9								
HCM 6th LOS				C								

Intersection												
Int Delay, s/veh	7.9											
Movement	EBL	EBT	EBR	WBL	WBT	WBR	NBL	NBT	NBR	SBL	SBT	SBR
Lane Configurations		↕			↕			↕			↕	
Traffic Vol, veh/h	4	42	23	67	45	8	7	9	46	23	9	1
Future Vol, veh/h	4	42	23	67	45	8	7	9	46	23	9	1
Conflicting Peds, #/hr	0	0	0	0	0	0	0	0	0	0	0	0
Sign Control	Stop	Stop	Stop	Stop	Stop	Stop	Free	Free	Free	Free	Free	Free
RT Channelized	-	-	None	-	-	None	-	-	None	-	-	None
Storage Length	-	-	-	-	-	-	-	-	-	-	-	-
Veh in Median Storage, #	-	0	-	-	0	-	-	0	-	-	0	-
Grade, %	-	0	-	-	0	-	-	0	-	-	0	-
Peak Hour Factor	79	79	79	79	79	79	79	79	79	79	79	79
Heavy Vehicles, %	2	2	2	2	2	2	2	2	2	2	2	2
Mvmt Flow	5	53	29	85	57	10	9	11	58	29	11	1

Major/Minor	Minor2		Minor1		Major1			Major2				
Conflicting Flow All	162	157	12	169	128	40	12	0	0	69	0	0
Stage 1	70	70	-	58	58	-	-	-	-	-	-	-
Stage 2	92	87	-	111	70	-	-	-	-	-	-	-
Critical Hdwy	7.12	6.52	6.22	7.12	6.52	6.22	4.12	-	-	4.12	-	-
Critical Hdwy Stg 1	6.12	5.52	-	6.12	5.52	-	-	-	-	-	-	-
Critical Hdwy Stg 2	6.12	5.52	-	6.12	5.52	-	-	-	-	-	-	-
Follow-up Hdwy	3.518	4.018	3.318	3.518	4.018	3.318	2.218	-	-	2.218	-	-
Pot Cap-1 Maneuver	803	735	1069	795	763	1031	1607	-	-	1532	-	-
Stage 1	940	837	-	954	847	-	-	-	-	-	-	-
Stage 2	915	823	-	894	837	-	-	-	-	-	-	-
Platoon blocked, %								-	-	-	-	-
Mov Cap-1 Maneuver	735	717	1069	716	744	1031	1607	-	-	1532	-	-
Mov Cap-2 Maneuver	735	717	-	716	744	-	-	-	-	-	-	-
Stage 1	934	821	-	948	842	-	-	-	-	-	-	-
Stage 2	840	818	-	798	821	-	-	-	-	-	-	-

Approach	EB	WB	NB	SB
HCM Control Delay, s	10	11.1	0.8	5.2
HCM LOS	B	B		

Minor Lane/Major Mvmt	NBL	NBT	NBR	EBLn1WBLn1	SBL	SBT	SBR
Capacity (veh/h)	1607	-	-	807	742	1532	-
HCM Lane V/C Ratio	0.006	-	-	0.108	0.205	0.019	-
HCM Control Delay (s)	7.3	0	-	10	11.1	7.4	0
HCM Lane LOS	A	A	-	B	B	A	A
HCM 95th %tile Q(veh)	0	-	-	0.4	0.8	0.1	-

Heritage at Dalia Ranch
6: Imperial Ave & Worthington Rd/Barioni Blvd

Opening Year 2024 + P1-2 Proj
Timing Plan: AM PEAK

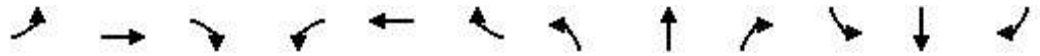

Movement	EBL	EBT	EBR	WBL	WBT	WBR	NBL	NBT	NBR	SBL	SBT	SBR
Lane Configurations		↕	↗		↕	↗	↖	↕↗		↖	↕↗	
Traffic Volume (veh/h)	71	138	215	55	133	84	94	501	51	54	727	56
Future Volume (veh/h)	71	138	215	55	133	84	94	501	51	54	727	56
Initial Q (Qb), veh	0	0	0	0	0	0	0	0	0	0	0	0
Ped-Bike Adj(A_pbT)	1.00		1.00	1.00		1.00	1.00		1.00	1.00		1.00
Parking Bus, Adj	1.00	1.00	1.00	1.00	1.00	1.00	1.00	1.00	1.00	1.00	1.00	1.00
Work Zone On Approach		No			No			No			No	
Adj Sat Flow, veh/h/ln	1870	1870	1870	1870	1870	1870	1870	1870	1870	1870	1870	1870
Adj Flow Rate, veh/h	80	155	242	62	149	94	106	563	57	61	817	63
Peak Hour Factor	0.89	0.89	0.89	0.89	0.89	0.89	0.89	0.89	0.89	0.89	0.89	0.89
Percent Heavy Veh, %	2	2	2	2	2	2	2	2	2	2	2	2
Cap, veh/h	121	235	307	83	200	243	134	980	99	91	924	71
Arrive On Green	0.19	0.19	0.19	0.15	0.15	0.15	0.08	0.30	0.30	0.05	0.28	0.28
Sat Flow, veh/h	626	1213	1585	542	1302	1585	1781	3259	329	1781	3343	258
Grp Volume(v), veh/h	235	0	242	211	0	94	106	306	314	61	434	446
Grp Sat Flow(s),veh/h/ln	1839	0	1585	1843	0	1585	1781	1777	1811	1781	1777	1824
Q Serve(g_s), s	7.8	0.0	9.6	7.3	0.0	3.5	3.9	9.7	9.7	2.2	15.5	15.5
Cycle Q Clear(g_c), s	7.8	0.0	9.6	7.3	0.0	3.5	3.9	9.7	9.7	2.2	15.5	15.5
Prop In Lane	0.34		1.00	0.29		1.00	1.00		0.18	1.00		0.14
Lane Grp Cap(c), veh/h	356	0	307	283	0	243	134	534	545	91	491	504
V/C Ratio(X)	0.66	0.00	0.79	0.75	0.00	0.39	0.79	0.57	0.58	0.67	0.88	0.88
Avail Cap(c_a), veh/h	498	0	429	499	0	429	134	534	545	134	508	522
HCM Platoon Ratio	1.00	1.00	1.00	1.00	1.00	1.00	1.00	1.00	1.00	1.00	1.00	1.00
Upstream Filter(l)	1.00	0.00	1.00	1.00	0.00	1.00	1.00	1.00	1.00	1.00	1.00	1.00
Uniform Delay (d), s/veh	24.8	0.0	25.5	26.9	0.0	25.3	30.2	19.6	19.6	31.0	23.0	23.0
Incr Delay (d2), s/veh	2.1	0.0	6.4	3.9	0.0	1.0	26.6	1.5	1.5	8.4	16.4	16.1
Initial Q Delay(d3),s/veh	0.0	0.0	0.0	0.0	0.0	0.0	0.0	0.0	0.0	0.0	0.0	0.0
%ile BackOfQ(50%),veh/ln	3.4	0.0	4.0	3.3	0.0	1.3	2.6	3.9	4.0	1.1	8.2	8.4
Unsig. Movement Delay, s/veh												
LnGrp Delay(d),s/veh	26.8	0.0	31.9	30.8	0.0	26.3	56.8	21.1	21.1	39.4	39.4	39.1
LnGrp LOS	C	A	C	C	A	C	E	C	C	D	D	D
Approach Vol, veh/h		477			305			726			941	
Approach Delay, s/veh		29.4			29.4			26.3			39.3	
Approach LOS		C			C			C			D	
Timer - Assigned Phs	1	2		4	5	6		8				
Phs Duration (G+Y+Rc), s	8.4	25.0		17.9	10.0	23.4		15.2				
Change Period (Y+Rc), s	5.0	5.0		5.0	5.0	5.0		5.0				
Max Green Setting (Gmax), s	5.0	19.0		18.0	5.0	19.0		18.0				
Max Q Clear Time (g_c+I1), s	4.2	11.7		11.6	5.9	17.5		9.3				
Green Ext Time (p_c), s	0.0	2.2		1.2	0.0	0.8		1.0				
Intersection Summary												
HCM 6th Ctrl Delay				32.3								
HCM 6th LOS				C								

Intersection												
Intersection Delay, s/veh	21.1											
Intersection LOS	C											

Movement	EBL	EBT	EBR	WBL	WBT	WBR	NBL	NBT	NBR	SBL	SBT	SBR
Lane Configurations		↔	↔		↔	↔		↔			↔	
Traffic Vol, veh/h	68	395	121	11	305	78	0	0	1	107	31	79
Future Vol, veh/h	68	395	121	11	305	78	0	0	1	107	31	79
Peak Hour Factor	0.92	0.92	0.92	0.92	0.92	0.92	0.92	0.92	0.92	0.92	0.92	0.92
Heavy Vehicles, %	2	2	2	2	2	2	2	2	2	2	2	2
Mvmt Flow	74	429	132	12	332	85	0	0	1	116	34	86
Number of Lanes	0	1	1	0	1	1	0	1	0	0	1	0

Approach	EB	WB	NB	SB
Opposing Approach	WB	EB	SB	NB
Opposing Lanes	2	2	1	1
Conflicting Approach Left	SB	NB	EB	WB
Conflicting Lanes Left	1	1	2	2
Conflicting Approach Right	NB	SB	WB	EB
Conflicting Lanes Right	1	1	2	2
HCM Control Delay	27.4	15.8	9.7	13.8
HCM LOS	D	C	A	B

Lane	NBLn1	EBLn1	EBLn2	WBLn1	WBLn2	SBLn1
Vol Left, %	0%	15%	0%	3%	0%	49%
Vol Thru, %	0%	85%	0%	97%	0%	14%
Vol Right, %	100%	0%	100%	0%	100%	36%
Sign Control	Stop	Stop	Stop	Stop	Stop	Stop
Traffic Vol by Lane	1	463	121	316	78	217
LT Vol	0	68	0	11	0	107
Through Vol	0	395	0	305	0	31
RT Vol	1	0	121	0	78	79
Lane Flow Rate	1	503	132	343	85	236
Geometry Grp	2	7	7	7	7	2
Degree of Util (X)	0.002	0.836	0.19	0.589	0.128	0.413
Departure Headway (Hd)	6.71	5.982	5.197	6.171	5.442	6.302
Convergence, Y/N	Yes	Yes	Yes	Yes	Yes	Yes
Cap	537	604	688	584	656	568
Service Time	4.71	3.729	2.944	3.927	3.197	4.36
HCM Lane V/C Ratio	0.002	0.833	0.192	0.587	0.13	0.415
HCM Control Delay	9.7	32.1	9.2	17.5	9	13.8
HCM Lane LOS	A	D	A	C	A	B
HCM 95th-tile Q	0	8.9	0.7	3.8	0.4	2

Heritage at Dalia Ranch
8: Imperial Ave & Aten Rd

Opening Year 2024 + P1-2 Proj
Timing Plan: AM PEAK



Movement	EBL	EBT	EBR	WBL	WBT	WBR	NBL	NBT	NBR	SBL	SBT	SBR
Lane Configurations	↖	↖↗		↖	↖↗		↖	↖↗	↖	↖	↖↗	↖
Traffic Volume (veh/h)	195	342	64	132	303	149	62	368	68	158	740	395
Future Volume (veh/h)	195	342	64	132	303	149	62	368	68	158	740	395
Initial Q (Qb), veh	0	0	0	0	0	0	0	0	0	0	0	0
Ped-Bike Adj(A_pbT)	1.00		1.00	1.00		1.00	1.00		1.00	1.00		1.00
Parking Bus, Adj	1.00	1.00	1.00	1.00	1.00	1.00	1.00	1.00	1.00	1.00	1.00	1.00
Work Zone On Approach		No		No		No		No		No		No
Adj Sat Flow, veh/h/ln	1870	1870	1870	1870	1870	1870	1870	1870	1870	1870	1870	1870
Adj Flow Rate, veh/h	227	398	74	153	352	173	72	428	79	184	860	459
Peak Hour Factor	0.86	0.86	0.86	0.86	0.86	0.86	0.86	0.86	0.86	0.86	0.86	0.86
Percent Heavy Veh, %	2	2	2	2	2	2	2	2	2	2	2	2
Cap, veh/h	257	704	130	191	461	223	96	901	402	206	1119	499
Arrive On Green	0.14	0.24	0.24	0.11	0.20	0.20	0.05	0.25	0.25	0.12	0.31	0.31
Sat Flow, veh/h	1781	2995	552	1781	2323	1122	1781	3554	1585	1781	3554	1585
Grp Volume(v), veh/h	227	235	237	153	268	257	72	428	79	184	860	459
Grp Sat Flow(s),veh/h/ln	1781	1777	1771	1781	1777	1668	1781	1777	1585	1781	1777	1585
Q Serve(g_s), s	8.7	8.1	8.2	5.8	9.9	10.1	2.8	7.1	2.7	7.1	15.2	19.4
Cycle Q Clear(g_c), s	8.7	8.1	8.2	5.8	9.9	10.1	2.8	7.1	2.7	7.1	15.2	19.4
Prop In Lane	1.00		0.31	1.00		0.67	1.00		1.00	1.00		1.00
Lane Grp Cap(c), veh/h	257	418	417	191	352	331	96	901	402	206	1119	499
V/C Ratio(X)	0.88	0.56	0.57	0.80	0.76	0.78	0.75	0.47	0.20	0.90	0.77	0.92
Avail Cap(c_a), veh/h	257	487	485	231	461	433	128	974	434	206	1128	503
HCM Platoon Ratio	1.00	1.00	1.00	1.00	1.00	1.00	1.00	1.00	1.00	1.00	1.00	1.00
Upstream Filter(l)	1.00	1.00	1.00	1.00	1.00	1.00	1.00	1.00	1.00	1.00	1.00	1.00
Uniform Delay (d), s/veh	29.1	23.4	23.4	30.2	26.2	26.3	32.3	22.0	20.3	30.3	21.5	22.9
Incr Delay (d2), s/veh	28.2	1.2	1.2	15.1	5.3	6.5	15.2	0.4	0.2	35.6	3.3	22.1
Initial Q Delay(d3),s/veh	0.0	0.0	0.0	0.0	0.0	0.0	0.0	0.0	0.0	0.0	0.0	0.0
%ile BackOfQ(50%),veh/ln	5.6	3.3	3.4	3.2	4.5	4.4	1.6	2.8	1.0	4.9	6.4	9.7
Unsig. Movement Delay, s/veh												
LnGrp Delay(d),s/veh	57.3	24.5	24.6	45.3	31.5	32.8	47.5	22.3	20.6	65.9	24.7	45.0
LnGrp LOS	E	C	C	D	C	C	D	C	C	E	C	D
Approach Vol, veh/h		699			678			579			1503	
Approach Delay, s/veh		35.2			35.1			25.2			36.0	
Approach LOS		D			D			C			D	
Timer - Assigned Phs	1	2	3	4	5	6	7	8				
Phs Duration (G+Y+Rc), s	3.0	22.6	12.4	21.3	8.8	26.8	15.0	18.8				
Change Period (Y+Rc), s	5.0	5.0	5.0	5.0	5.0	5.0	5.0	5.0				
Max Green Setting (Gmax), s	3.0	19.0	9.0	19.0	5.0	22.0	10.0	18.0				
Max Q Clear Time (g_c+1), s	19.0	9.1	7.8	10.2	4.8	21.4	10.7	12.1				
Green Ext Time (p_c), s	0.0	2.2	0.0	1.9	0.0	0.5	0.0	1.6				
Intersection Summary												
HCM 6th Ctrl Delay											33.9	
HCM 6th LOS											C	

Intersection						
Int Delay, s/veh	3.4					
Movement	EBL	EBT	WBT	WBR	SBL	SBR
Lane Configurations	↔	↑	↔		↔	↔
Traffic Vol, veh/h	3	113	112	38	111	7
Future Vol, veh/h	3	113	112	38	111	7
Conflicting Peds, #/hr	0	0	0	0	0	0
Sign Control	Free	Free	Free	Free	Stop	Stop
RT Channelized	-	None	-	None	-	None
Storage Length	50	-	-	-	0	0
Veh in Median Storage, #	-	0	0	-	0	-
Grade, %	-	0	0	-	0	-
Peak Hour Factor	92	92	92	92	92	92
Heavy Vehicles, %	2	2	2	2	2	2
Mvmt Flow	3	123	122	41	121	8

Major/Minor	Major1	Major2	Minor2		
Conflicting Flow All	163	0	-	0	272
Stage 1	-	-	-	-	143
Stage 2	-	-	-	-	129
Critical Hdwy	4.12	-	-	-	6.42
Critical Hdwy Stg 1	-	-	-	-	5.42
Critical Hdwy Stg 2	-	-	-	-	5.42
Follow-up Hdwy	2.218	-	-	-	3.518
Pot Cap-1 Maneuver	1416	-	-	-	717
Stage 1	-	-	-	-	884
Stage 2	-	-	-	-	897
Platoon blocked, %		-	-	-	
Mov Cap-1 Maneuver	1416	-	-	-	716
Mov Cap-2 Maneuver	-	-	-	-	716
Stage 1	-	-	-	-	882
Stage 2	-	-	-	-	897

Approach	EB	WB	SB
HCM Control Delay, s	0.2	0	10.9
HCM LOS			B

Minor Lane/Major Mvmt	EBL	EBT	WBT	WBR	SBLn1	SBLn2
Capacity (veh/h)	1416	-	-	-	716	905
HCM Lane V/C Ratio	0.002	-	-	-	0.169	0.008
HCM Control Delay (s)	7.5	-	-	-	11	9
HCM Lane LOS	A	-	-	-	B	A
HCM 95th %tile Q(veh)	0	-	-	-	0.6	0

Intersection						
Int Delay, s/veh	4.8					
Movement	WBL	WBR	NBT	NBR	SBL	SBT
Lane Configurations	↘	↗	↖		↘	↗
Traffic Vol, veh/h	30	0	10	10	0	4
Future Vol, veh/h	30	0	10	10	0	4
Conflicting Peds, #/hr	0	0	0	0	0	0
Sign Control	Stop	Stop	Free	Free	Free	Free
RT Channelized	-	None	-	None	-	None
Storage Length	0	0	-	-	50	-
Veh in Median Storage, #	0	-	0	-	-	0
Grade, %	0	-	0	-	-	0
Peak Hour Factor	92	92	92	92	92	92
Heavy Vehicles, %	2	2	2	2	2	2
Mvmt Flow	33	0	11	11	0	4

Major/Minor	Minor1	Major1	Major2		
Conflicting Flow All	21	17	0	0	22
Stage 1	17	-	-	-	-
Stage 2	4	-	-	-	-
Critical Hdwy	6.42	6.22	-	-	4.12
Critical Hdwy Stg 1	5.42	-	-	-	-
Critical Hdwy Stg 2	5.42	-	-	-	-
Follow-up Hdwy	3.518	3.318	-	-	2.218
Pot Cap-1 Maneuver	996	1062	-	-	1593
Stage 1	1006	-	-	-	-
Stage 2	1019	-	-	-	-
Platoon blocked, %			-	-	-
Mov Cap-1 Maneuver	996	1062	-	-	1593
Mov Cap-2 Maneuver	996	-	-	-	-
Stage 1	1006	-	-	-	-
Stage 2	1019	-	-	-	-

Approach	WB	NB	SB
HCM Control Delay, s	8.7	0	0
HCM LOS	A		

Minor Lane/Major Mvmt	NBT	NBRWBLn1	WBLn2	SBL	SBT
Capacity (veh/h)	-	-	996	-	1593
HCM Lane V/C Ratio	-	-	0.033	-	-
HCM Control Delay (s)	-	-	8.7	0	0
HCM Lane LOS	-	-	A	A	A
HCM 95th %tile Q(veh)	-	-	0.1	-	0

Intersection												
Int Delay, s/veh	0.3											
Movement	EBL	EBT	EBR	WBL	WBT	WBR	NBL	NBT	NBR	SBL	SBT	SBR
Lane Configurations		↕			↕		↕	↕		↕	↕	
Traffic Vol, veh/h	6	4	0	7	0	5	1	589	7	6	620	18
Future Vol, veh/h	6	4	0	7	0	5	1	589	7	6	620	18
Conflicting Peds, #/hr	0	0	0	0	0	0	0	0	0	0	0	0
Sign Control	Stop	Stop	Stop	Stop	Stop	Stop	Free	Free	Free	Free	Free	Free
RT Channelized	-	-	None	-	-	None	-	-	None	-	-	None
Storage Length	-	-	-	-	-	-	50	-	-	50	-	-
Veh in Median Storage, #	-	1	-	-	1	-	-	0	-	-	0	-
Grade, %	-	0	-	-	0	-	-	0	-	-	0	-
Peak Hour Factor	92	92	92	92	92	92	92	92	92	92	92	92
Heavy Vehicles, %	2	2	2	2	2	2	2	2	2	2	2	2
Mvmt Flow	7	4	0	8	0	5	1	640	8	7	674	20

Major/Minor	Minor2		Minor1		Major1			Major2				
Conflicting Flow All	1020	1348	347	999	1354	324	694	0	0	648	0	0
Stage 1	698	698	-	646	646	-	-	-	-	-	-	-
Stage 2	322	650	-	353	708	-	-	-	-	-	-	-
Critical Hdwy	7.54	6.54	6.94	7.54	6.54	6.94	4.14	-	-	4.14	-	-
Critical Hdwy Stg 1	6.54	5.54	-	6.54	5.54	-	-	-	-	-	-	-
Critical Hdwy Stg 2	6.54	5.54	-	6.54	5.54	-	-	-	-	-	-	-
Follow-up Hdwy	3.52	4.02	3.32	3.52	4.02	3.32	2.22	-	-	2.22	-	-
Pot Cap-1 Maneuver	191	150	649	198	148	672	897	-	-	934	-	-
Stage 1	397	440	-	427	465	-	-	-	-	-	-	-
Stage 2	664	463	-	637	436	-	-	-	-	-	-	-
Platoon blocked, %								-	-	-	-	-
Mov Cap-1 Maneuver	188	149	649	194	147	672	897	-	-	934	-	-
Mov Cap-2 Maneuver	303	272	-	315	271	-	-	-	-	-	-	-
Stage 1	397	437	-	427	465	-	-	-	-	-	-	-
Stage 2	658	463	-	626	433	-	-	-	-	-	-	-

Approach	EB		WB		NB		SB	
HCM Control Delay, s	17.9		14.2		0		0.1	
HCM LOS	C		B					

Minor Lane/Major Mvmt	NBL	NBT	NBR	EBLn1WBLn1	SBL	SBT	SBR
Capacity (veh/h)	897	-	-	290	405	934	-
HCM Lane V/C Ratio	0.001	-	-	0.037	0.032	0.007	-
HCM Control Delay (s)	9	-	-	17.9	14.2	8.9	-
HCM Lane LOS	A	-	-	C	B	A	-
HCM 95th %tile Q(veh)	0	-	-	0.1	0.1	0	-

Intersection						
Int Delay, s/veh	0.7					
Movement	WBL	WBR	NBT	NBR	SBL	SBT
Lane Configurations	↔		↑↓		↔	↑↑
Traffic Vol, veh/h	20	10	590	30	30	583
Future Vol, veh/h	20	10	590	30	30	583
Conflicting Peds, #/hr	0	0	0	0	0	0
Sign Control	Stop	Stop	Free	Free	Free	Free
RT Channelized	-	None	-	None	-	None
Storage Length	0	-	-	-	140	-
Veh in Median Storage, #	0	-	0	-	-	0
Grade, %	0	-	0	-	-	0
Peak Hour Factor	91	91	91	91	91	91
Heavy Vehicles, %	2	2	2	2	2	2
Mvmt Flow	22	11	648	33	33	641

Major/Minor	Minor1	Major1	Major2			
Conflicting Flow All	1052	341	0	0	681	0
Stage 1	665	-	-	-	-	-
Stage 2	387	-	-	-	-	-
Critical Hdwy	6.84	6.94	-	-	4.14	-
Critical Hdwy Stg 1	5.84	-	-	-	-	-
Critical Hdwy Stg 2	5.84	-	-	-	-	-
Follow-up Hdwy	3.52	3.32	-	-	2.22	-
Pot Cap-1 Maneuver	222	655	-	-	907	-
Stage 1	473	-	-	-	-	-
Stage 2	656	-	-	-	-	-
Platoon blocked, %			-	-		-
Mov Cap-1 Maneuver	214	655	-	-	907	-
Mov Cap-2 Maneuver	214	-	-	-	-	-
Stage 1	473	-	-	-	-	-
Stage 2	632	-	-	-	-	-

Approach	WB	NB	SB
HCM Control Delay, s	19.8	0	0.4
HCM LOS	C		

Minor Lane/Major Mvmt	NBT	NBRWBLn1	SBL	SBT
Capacity (veh/h)	-	-	276	907
HCM Lane V/C Ratio	-	-	0.119	0.036
HCM Control Delay (s)	-	-	19.8	9.1
HCM Lane LOS	-	-	C	A
HCM 95th %tile Q(veh)	-	-	0.4	0.1

Intersection												
Int Delay, s/veh	7.5											
Movement	EBL	EBT	EBR	WBL	WBT	WBR	NBL	NBT	NBR	SBL	SBT	SBR
Lane Configurations		↕			↕			↕			↕	
Traffic Vol, veh/h	2	39	8	28	45	26	5	14	18	14	10	7
Future Vol, veh/h	2	39	8	28	45	26	5	14	18	14	10	7
Conflicting Peds, #/hr	0	0	0	0	0	0	0	0	0	0	0	0
Sign Control	Stop	Stop	Stop	Stop	Stop	Stop	Free	Free	Free	Free	Free	Free
RT Channelized	-	-	None	-	-	None	-	-	None	-	-	None
Storage Length	-	-	-	-	-	-	-	-	-	-	-	-
Veh in Median Storage, #	-	0	-	-	0	-	-	0	-	-	0	-
Grade, %	-	0	-	-	0	-	-	0	-	-	0	-
Peak Hour Factor	79	79	79	79	79	79	79	79	79	79	79	79
Heavy Vehicles, %	2	2	2	2	2	2	2	2	2	2	2	2
Mvmt Flow	3	49	10	35	57	33	6	18	23	18	13	9

Major/Minor	Minor2		Minor1		Major1			Major2				
Conflicting Flow All	141	107	18	125	100	30	22	0	0	41	0	0
Stage 1	54	54	-	42	42	-	-	-	-	-	-	-
Stage 2	87	53	-	83	58	-	-	-	-	-	-	-
Critical Hdwy	7.12	6.52	6.22	7.12	6.52	6.22	4.12	-	-	4.12	-	-
Critical Hdwy Stg 1	6.12	5.52	-	6.12	5.52	-	-	-	-	-	-	-
Critical Hdwy Stg 2	6.12	5.52	-	6.12	5.52	-	-	-	-	-	-	-
Follow-up Hdwy	3.518	4.018	3.318	3.518	4.018	3.318	2.218	-	-	2.218	-	-
Pot Cap-1 Maneuver	829	783	1061	849	790	1044	1593	-	-	1568	-	-
Stage 1	958	850	-	972	860	-	-	-	-	-	-	-
Stage 2	921	851	-	925	847	-	-	-	-	-	-	-
Platoon blocked, %								-	-	-	-	-
Mov Cap-1 Maneuver	749	770	1061	790	777	1044	1593	-	-	1568	-	-
Mov Cap-2 Maneuver	749	770	-	790	777	-	-	-	-	-	-	-
Stage 1	954	840	-	968	857	-	-	-	-	-	-	-
Stage 2	829	848	-	852	837	-	-	-	-	-	-	-

Approach	EB		WB		NB		SB	
HCM Control Delay, s	9.8		10.1		1		3.3	
HCM LOS	A		B					

Minor Lane/Major Mvmt	NBL	NBT	NBR	EBLn1WBLn1	SBL	SBT	SBR
Capacity (veh/h)	1593	-	-	805	837	1568	-
HCM Lane V/C Ratio	0.004	-	-	0.077	0.15	0.011	-
HCM Control Delay (s)	7.3	0	-	9.8	10.1	7.3	0
HCM Lane LOS	A	A	-	A	B	A	A
HCM 95th %tile Q(veh)	0	-	-	0.2	0.5	0	-

Heritage at Dalia Ranch
7: La Brucherie Rd & Worthington Rd

Opening Year 2024 + P1-2 Proj
Timing Plan: PM PEAK

Intersection												
Intersection Delay, s/veh	11											
Intersection LOS	B											

Movement	EBL	EBT	EBR	WBL	WBT	WBR	NBL	NBT	NBR	SBL	SBT	SBR
Lane Configurations		↔	↔		↔	↔		↔			↔	
Traffic Vol, veh/h	42	190	33	27	218	34	1	0	0	38	5	34
Future Vol, veh/h	42	190	33	27	218	34	1	0	0	38	5	34
Peak Hour Factor	0.80	0.80	0.80	0.80	0.80	0.80	0.80	0.80	0.80	0.80	0.80	0.80
Heavy Vehicles, %	2	2	2	2	2	2	2	2	2	2	2	2
Mvmt Flow	53	238	41	34	273	43	1	0	0	48	6	43
Number of Lanes	0	1	1	0	1	1	0	1	0	0	1	0

Approach	EB	WB	NB	SB
Opposing Approach	WB	EB	SB	NB
Opposing Lanes	2	2	1	1
Conflicting Approach Left	SB	NB	EB	WB
Conflicting Lanes Left	1	1	2	2
Conflicting Approach Right	NB	SB	WB	EB
Conflicting Lanes Right	1	1	2	2
HCM Control Delay	11.1	11.3	9	9.3
HCM LOS	B	B	A	A

Lane	NBLn1	EBLn1	EBLn2	WBLn1	WBLn2	SBLn1
Vol Left, %	100%	18%	0%	11%	0%	49%
Vol Thru, %	0%	82%	0%	89%	0%	6%
Vol Right, %	0%	0%	100%	0%	100%	44%
Sign Control	Stop	Stop	Stop	Stop	Stop	Stop
Traffic Vol by Lane	1	232	33	245	34	77
LT Vol	1	42	0	27	0	38
Through Vol	0	190	0	218	0	5
RT Vol	0	0	33	0	34	34
Lane Flow Rate	1	290	41	306	42	96
Geometry Grp	2	7	7	7	7	2
Degree of Util (X)	0.002	0.418	0.05	0.437	0.052	0.143
Departure Headway (Hd)	5.882	5.186	4.391	5.138	4.378	5.331
Convergence, Y/N	Yes	Yes	Yes	Yes	Yes	Yes
Cap	604	693	812	698	815	670
Service Time	3.963	2.932	2.136	2.882	2.122	3.387
HCM Lane V/C Ratio	0.002	0.418	0.05	0.438	0.052	0.143
HCM Control Delay	9	11.6	7.4	11.8	7.4	9.3
HCM Lane LOS	A	B	A	B	A	A
HCM 95th-tile Q	0	2.1	0.2	2.2	0.2	0.5

Intersection						
Int Delay, s/veh	2.4					
Movement	EBL	EBT	WBT	WBR	SBL	SBR
Lane Configurations	↔	↑	↔		↔	↔
Traffic Vol, veh/h	8	57	84	126	72	5
Future Vol, veh/h	8	57	84	126	72	5
Conflicting Peds, #/hr	0	0	0	0	0	0
Sign Control	Free	Free	Free	Free	Stop	Stop
RT Channelized	-	None	-	None	-	None
Storage Length	50	-	-	-	0	0
Veh in Median Storage, #	-	0	0	-	0	-
Grade, %	-	0	0	-	0	-
Peak Hour Factor	92	92	92	92	92	92
Heavy Vehicles, %	2	2	2	2	2	2
Mvmt Flow	9	62	91	137	78	5

Major/Minor	Major1	Major2	Minor2		
Conflicting Flow All	228	0	-	0	240 160
Stage 1	-	-	-	-	160 -
Stage 2	-	-	-	-	80 -
Critical Hdwy	4.12	-	-	-	6.42 6.22
Critical Hdwy Stg 1	-	-	-	-	5.42 -
Critical Hdwy Stg 2	-	-	-	-	5.42 -
Follow-up Hdwy	2.218	-	-	-	3.518 3.318
Pot Cap-1 Maneuver	1340	-	-	-	748 885
Stage 1	-	-	-	-	869 -
Stage 2	-	-	-	-	943 -
Platoon blocked, %		-	-	-	
Mov Cap-1 Maneuver	1340	-	-	-	743 885
Mov Cap-2 Maneuver	-	-	-	-	743 -
Stage 1	-	-	-	-	863 -
Stage 2	-	-	-	-	943 -

Approach	EB	WB	SB
HCM Control Delay, s	0.9	0	10.3
HCM LOS			B

Minor Lane/Major Mvmt	EBL	EBT	WBT	WBR	SBLn1	SBLn2
Capacity (veh/h)	1340	-	-	-	743	885
HCM Lane V/C Ratio	0.006	-	-	-	0.105	0.006
HCM Control Delay (s)	7.7	-	-	-	10.4	9.1
HCM Lane LOS	A	-	-	-	B	A
HCM 95th %tile Q(veh)	0	-	-	-	0.4	0

Intersection						
Int Delay, s/veh	2.2					
Movement	WBL	WBR	NBT	NBR	SBL	SBT
Lane Configurations	↙	↗	↖		↙	↗
Traffic Vol, veh/h	19	0	9	34	0	13
Future Vol, veh/h	19	0	9	34	0	13
Conflicting Peds, #/hr	0	0	0	0	0	0
Sign Control	Stop	Stop	Free	Free	Free	Free
RT Channelized	-	None	-	None	-	None
Storage Length	0	0	-	-	50	-
Veh in Median Storage, #	0	-	0	-	-	0
Grade, %	0	-	0	-	-	0
Peak Hour Factor	92	92	92	92	92	92
Heavy Vehicles, %	2	2	2	2	2	2
Mvmt Flow	21	0	10	37	0	14

Major/Minor	Minor1	Major1	Major2		
Conflicting Flow All	43	29	0	0	47
Stage 1	29	-	-	-	-
Stage 2	14	-	-	-	-
Critical Hdwy	6.42	6.22	-	-	4.12
Critical Hdwy Stg 1	5.42	-	-	-	-
Critical Hdwy Stg 2	5.42	-	-	-	-
Follow-up Hdwy	3.518	3.318	-	-	2.218
Pot Cap-1 Maneuver	968	1046	-	-	1560
Stage 1	994	-	-	-	-
Stage 2	1009	-	-	-	-
Platoon blocked, %			-	-	-
Mov Cap-1 Maneuver	968	1046	-	-	1560
Mov Cap-2 Maneuver	968	-	-	-	-
Stage 1	994	-	-	-	-
Stage 2	1009	-	-	-	-

Approach	WB	NB	SB
HCM Control Delay, s	8.8	0	0
HCM LOS	A		

Minor Lane/Major Mvmt	NBT	NBRWBLn1	WBLn2	SBL	SBT
Capacity (veh/h)	-	-	968	-	1560
HCM Lane V/C Ratio	-	-	0.021	-	-
HCM Control Delay (s)	-	-	8.8	0	0
HCM Lane LOS	-	-	A	A	A
HCM 95th %tile Q(veh)	-	-	0.1	-	0

Heritage at Dalia Ranch
1: SR-86 & Keystone Rd

Opening Year 2026
Timing Plan: AM PEAK



Movement	EBL	EBT	EBR	WBL	WBT	WBR	NBL	NBT	NBR	SBL	SBT	SBR
Lane Configurations		↔			↔		↗	↕	↗	↗	↕	↗
Traffic Volume (veh/h)	34	34	12	19	25	44	19	485	51	47	543	39
Future Volume (veh/h)	34	34	12	19	25	44	19	485	51	47	543	39
Initial Q (Qb), veh	0	0	0	0	0	0	0	0	0	0	0	0
Ped-Bike Adj(A_pbT)	1.00		1.00	1.00		1.00	1.00		1.00	1.00		1.00
Parking Bus, Adj	1.00	1.00	1.00	1.00	1.00	1.00	1.00	1.00	1.00	1.00	1.00	1.00
Work Zone On Approach		No			No			No			No	
Adj Sat Flow, veh/h/ln	1870	1870	1870	1870	1870	1870	1870	1870	1870	1870	1870	1870
Adj Flow Rate, veh/h	38	38	13	21	28	49	21	539	57	52	603	43
Peak Hour Factor	0.90	0.90	0.90	0.90	0.90	0.90	0.90	0.90	0.90	0.90	0.90	0.90
Percent Heavy Veh, %	2	2	2	2	2	2	2	2	2	2	2	2
Cap, veh/h	254	110	32	184	75	110	48	1057	471	105	1170	522
Arrive On Green	0.13	0.13	0.13	0.13	0.13	0.13	0.03	0.30	0.30	0.06	0.33	0.33
Sat Flow, veh/h	592	827	243	264	560	824	1781	3554	1585	1781	3554	1585
Grp Volume(v), veh/h	89	0	0	98	0	0	21	539	57	52	603	43
Grp Sat Flow(s),veh/h/ln	1661	0	0	1648	0	0	1781	1777	1585	1781	1777	1585
Q Serve(g_s), s	0.0	0.0	0.0	0.2	0.0	0.0	0.3	3.7	0.8	0.8	4.0	0.5
Cycle Q Clear(g_c), s	1.3	0.0	0.0	1.5	0.0	0.0	0.3	3.7	0.8	0.8	4.0	0.5
Prop In Lane	0.43		0.15	0.21		0.50	1.00		1.00	1.00		1.00
Lane Grp Cap(c), veh/h	396	0	0	368	0	0	48	1057	471	105	1170	522
V/C Ratio(X)	0.22	0.00	0.00	0.27	0.00	0.00	0.44	0.51	0.12	0.50	0.52	0.08
Avail Cap(c_a), veh/h	1142	0	0	1134	0	0	303	2178	971	303	2178	971
HCM Platoon Ratio	1.00	1.00	1.00	1.00	1.00	1.00	1.00	1.00	1.00	1.00	1.00	1.00
Upstream Filter(l)	1.00	0.00	0.00	1.00	0.00	0.00	1.00	1.00	1.00	1.00	1.00	1.00
Uniform Delay (d), s/veh	11.6	0.0	0.0	11.7	0.0	0.0	14.1	8.5	7.5	13.4	8.0	6.8
Incr Delay (d2), s/veh	0.3	0.0	0.0	0.4	0.0	0.0	6.2	0.4	0.1	3.6	0.4	0.1
Initial Q Delay(d3),s/veh	0.0	0.0	0.0	0.0	0.0	0.0	0.0	0.0	0.0	0.0	0.0	0.0
%ile BackOfQ(50%),veh/ln	0.4	0.0	0.0	0.5	0.0	0.0	0.2	1.0	0.2	0.4	1.0	0.1
Unsig. Movement Delay, s/veh												
LnGrp Delay(d),s/veh	11.9	0.0	0.0	12.1	0.0	0.0	20.3	8.9	7.6	17.0	8.3	6.9
LnGrp LOS	B	A	A	B	A	A	C	A	A	B	A	A
Approach Vol, veh/h		89			98			617			698	
Approach Delay, s/veh		11.9			12.1			9.2			8.9	
Approach LOS		B			B			A			A	
Timer - Assigned Phs	1	2		4	5	6		8				
Phs Duration (G+Y+Rc), s	6.7	13.7		8.9	5.8	14.7		8.9				
Change Period (Y+Rc), s	5.0	5.0		5.0	5.0	5.0		5.0				
Max Green Setting (Gmax), s	5.0	18.0		18.0	5.0	18.0		18.0				
Max Q Clear Time (g_c+I1), s	2.8	5.7		3.3	2.3	6.0		3.5				
Green Ext Time (p_c), s	0.0	3.0		0.3	0.0	3.3		0.4				
Intersection Summary												
HCM 6th Ctrl Delay				9.4								
HCM 6th LOS				A								

Intersection												
Int Delay, s/veh	0.4											
Movement	EBL	EBT	EBR	WBL	WBT	WBR	NBL	NBT	NBR	SBL	SBT	SBR
Lane Configurations		↕			↕		↕	↕		↕	↕	
Traffic Vol, veh/h	20	3	2	1	2	5	0	554	1	1	548	8
Future Vol, veh/h	20	3	2	1	2	5	0	554	1	1	548	8
Conflicting Peds, #/hr	0	0	0	0	0	0	0	0	0	0	0	0
Sign Control	Stop	Stop	Stop	Stop	Stop	Stop	Free	Free	Free	Free	Free	Free
RT Channelized	-	-	None	-	-	None	-	-	None	-	-	None
Storage Length	-	-	-	-	-	-	50	-	-	50	-	-
Veh in Median Storage, #	-	1	-	-	1	-	-	0	-	-	0	-
Grade, %	-	0	-	-	0	-	-	0	-	-	0	-
Peak Hour Factor	94	94	94	94	94	94	94	94	94	94	94	94
Heavy Vehicles, %	2	2	2	2	2	2	2	2	2	2	2	2
Mvmt Flow	21	3	2	1	2	5	0	589	1	1	583	9

Major/Minor	Minor2		Minor1		Major1			Major2				
Conflicting Flow All	886	1180	296	885	1184	295	592	0	0	590	0	0
Stage 1	590	590	-	590	590	-	-	-	-	-	-	-
Stage 2	296	590	-	295	594	-	-	-	-	-	-	-
Critical Hdwy	7.54	6.54	6.94	7.54	6.54	6.94	4.14	-	-	4.14	-	-
Critical Hdwy Stg 1	6.54	5.54	-	6.54	5.54	-	-	-	-	-	-	-
Critical Hdwy Stg 2	6.54	5.54	-	6.54	5.54	-	-	-	-	-	-	-
Follow-up Hdwy	3.52	4.02	3.32	3.52	4.02	3.32	2.22	-	-	2.22	-	-
Pot Cap-1 Maneuver	239	189	700	239	188	701	980	-	-	982	-	-
Stage 1	461	493	-	461	493	-	-	-	-	-	-	-
Stage 2	688	493	-	689	491	-	-	-	-	-	-	-
Platoon blocked, %								-	-	-	-	-
Mov Cap-1 Maneuver	236	189	700	236	188	701	980	-	-	982	-	-
Mov Cap-2 Maneuver	352	311	-	352	310	-	-	-	-	-	-	-
Stage 1	461	493	-	461	493	-	-	-	-	-	-	-
Stage 2	680	493	-	682	491	-	-	-	-	-	-	-

Approach	EB		WB		NB		SB	
HCM Control Delay, s	15.8		12.5		0		0	
HCM LOS	C		B					

Minor Lane/Major Mvmt	NBL	NBT	NBR	EBLn1	WBLn1	SBL	SBT	SBR
Capacity (veh/h)	980	-	-	361	487	982	-	-
HCM Lane V/C Ratio	-	-	-	0.074	0.017	0.001	-	-
HCM Control Delay (s)	0	-	-	15.8	12.5	8.7	-	-
HCM Lane LOS	A	-	-	C	B	A	-	-
HCM 95th %tile Q(veh)	0	-	-	0.2	0.1	0	-	-

Intersection						
Int Delay, s/veh	1.6					
Movement	WBL	WBR	NBT	NBR	SBL	SBT
Lane Configurations	W		T		T	T
Traffic Vol, veh/h	61	24	532	43	20	530
Future Vol, veh/h	61	24	532	43	20	530
Conflicting Peds, #/hr	0	0	0	0	0	0
Sign Control	Stop	Stop	Free	Free	Free	Free
RT Channelized	-	None	-	None	-	None
Storage Length	0	-	-	-	140	-
Veh in Median Storage, #	0	-	0	-	-	0
Grade, %	0	-	0	-	-	0
Peak Hour Factor	91	91	91	91	91	91
Heavy Vehicles, %	2	2	2	2	2	2
Mvmt Flow	67	26	585	47	22	582

Major/Minor	Minor1	Major1	Major2			
Conflicting Flow All	944	316	0	0	632	0
Stage 1	609	-	-	-	-	-
Stage 2	335	-	-	-	-	-
Critical Hdwy	6.84	6.94	-	-	4.14	-
Critical Hdwy Stg 1	5.84	-	-	-	-	-
Critical Hdwy Stg 2	5.84	-	-	-	-	-
Follow-up Hdwy	3.52	3.32	-	-	2.22	-
Pot Cap-1 Maneuver	261	680	-	-	947	-
Stage 1	505	-	-	-	-	-
Stage 2	697	-	-	-	-	-
Platoon blocked, %			-	-		
Mov Cap-1 Maneuver	255	680	-	-	947	-
Mov Cap-2 Maneuver	255	-	-	-	-	-
Stage 1	505	-	-	-	-	-
Stage 2	681	-	-	-	-	-

Approach	WB	NB	SB
HCM Control Delay, s	21.5	0	0.3
HCM LOS	C		

Minor Lane/Major Mvmt	NBT	NBRWBLn1	SBL	SBT
Capacity (veh/h)	-	-	310	947
HCM Lane V/C Ratio	-	-	0.301	0.023
HCM Control Delay (s)	-	-	21.5	8.9
HCM Lane LOS	-	-	C	A
HCM 95th %tile Q(veh)	-	-	1.2	0.1

Heritage at Dalia Ranch
4: Imperial Ave & Neckel Rd

Opening Year 2026
Timing Plan: AM PEAK

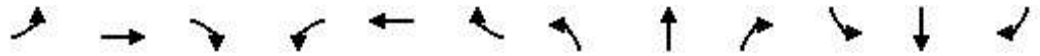

Movement	EBL	EBT	EBR	WBL	WBT	WBR	NBL	NBT	NBR	SBL	SBT	SBR
Lane Configurations		↕			↕		↕	↕		↕	↕	
Traffic Volume (veh/h)	35	45	13	228	66	85	9	461	95	24	533	32
Future Volume (veh/h)	35	45	13	228	66	85	9	461	95	24	533	32
Initial Q (Qb), veh	0	0	0	0	0	0	0	0	0	0	0	0
Ped-Bike Adj(A_pbT)	1.00		1.00	1.00		1.00	1.00		1.00	1.00		1.00
Parking Bus, Adj	1.00	1.00	1.00	1.00	1.00	1.00	1.00	1.00	1.00	1.00	1.00	1.00
Work Zone On Approach		No			No			No			No	
Adj Sat Flow, veh/h/ln	1870	1870	1870	1870	1870	1870	1870	1870	1870	1870	1870	1870
Adj Flow Rate, veh/h	38	49	14	251	73	93	10	507	104	26	586	35
Peak Hour Factor	0.91	0.91	0.91	0.91	0.91	0.91	0.91	0.91	0.91	0.91	0.91	0.91
Percent Heavy Veh, %	2	2	2	2	2	2	2	2	2	2	2	2
Cap, veh/h	52	67	19	294	86	109	23	710	145	53	881	53
Arrive On Green	0.08	0.08	0.08	0.28	0.28	0.28	0.01	0.24	0.24	0.03	0.26	0.26
Sat Flow, veh/h	674	869	248	1052	306	390	1781	2939	600	1781	3407	203
Grp Volume(v), veh/h	101	0	0	417	0	0	10	306	305	26	305	316
Grp Sat Flow(s),veh/h/ln	1792	0	0	1748	0	0	1781	1777	1762	1781	1777	1834
Q Serve(g_s), s	3.0	0.0	0.0	12.1	0.0	0.0	0.3	8.5	8.6	0.8	8.3	8.3
Cycle Q Clear(g_c), s	3.0	0.0	0.0	12.1	0.0	0.0	0.3	8.5	8.6	0.8	8.3	8.3
Prop In Lane	0.38		0.14	0.60		0.22	1.00		0.34	1.00		0.11
Lane Grp Cap(c), veh/h	138	0	0	489	0	0	23	429	426	53	459	474
V/C Ratio(X)	0.73	0.00	0.00	0.85	0.00	0.00	0.44	0.71	0.72	0.49	0.66	0.67
Avail Cap(c_a), veh/h	600	0	0	585	0	0	166	628	623	166	628	648
HCM Platoon Ratio	1.00	1.00	1.00	1.00	1.00	1.00	1.00	1.00	1.00	1.00	1.00	1.00
Upstream Filter(I)	1.00	0.00	0.00	1.00	0.00	0.00	1.00	1.00	1.00	1.00	1.00	1.00
Uniform Delay (d), s/veh	24.3	0.0	0.0	18.3	0.0	0.0	26.4	18.7	18.7	25.7	17.9	17.9
Incr Delay (d2), s/veh	7.3	0.0	0.0	10.2	0.0	0.0	12.4	2.2	2.3	6.8	1.7	1.6
Initial Q Delay(d3),s/veh	0.0	0.0	0.0	0.0	0.0	0.0	0.0	0.0	0.0	0.0	0.0	0.0
%ile BackOfQ(50%),veh/ln	1.4	0.0	0.0	5.7	0.0	0.0	0.2	3.4	3.4	0.4	3.2	3.3
Unsig. Movement Delay, s/veh												
LnGrp Delay(d),s/veh	31.6	0.0	0.0	28.5	0.0	0.0	38.8	20.9	21.0	32.4	19.5	19.5
LnGrp LOS	C	A	A	C	A	A	D	C	C	C	B	B
Approach Vol, veh/h		101			417			621				647
Approach Delay, s/veh		31.6			28.5			21.2				20.0
Approach LOS		C			C			C				C
Timer - Assigned Phs	1	2		4	5	6		8				
Phs Duration (G+Y+Rc), s	6.6	18.0		9.1	5.7	18.9		20.1				
Change Period (Y+Rc), s	5.0	5.0		5.0	5.0	5.0		5.0				
Max Green Setting (Gmax), s	5.0	19.0		18.0	5.0	19.0		18.0				
Max Q Clear Time (g_c+I1), s	2.8	10.6		5.0	2.3	10.3		14.1				
Green Ext Time (p_c), s	0.0	2.4		0.3	0.0	2.5		0.9				
Intersection Summary												
HCM 6th Ctrl Delay				23.1								
HCM 6th LOS				C								

Intersection												
Int Delay, s/veh	7.7											
Movement	EBL	EBT	EBR	WBL	WBT	WBR	NBL	NBT	NBR	SBL	SBT	SBR
Lane Configurations		↕			↕			↕			↕	
Traffic Vol, veh/h	4	43	24	62	46	0	8	6	44	1	2	1
Future Vol, veh/h	4	43	24	62	46	0	8	6	44	1	2	1
Conflicting Peds, #/hr	0	0	0	0	0	0	0	0	0	0	0	0
Sign Control	Stop	Stop	Stop	Stop	Stop	Stop	Free	Free	Free	Free	Free	Free
RT Channelized	-	-	None	-	-	None	-	-	None	-	-	None
Storage Length	-	-	-	-	-	-	-	-	-	-	-	-
Veh in Median Storage, #	-	0	-	-	0	-	-	0	-	-	0	-
Grade, %	-	0	-	-	0	-	-	0	-	-	0	-
Peak Hour Factor	79	79	79	79	79	79	79	79	79	79	79	79
Heavy Vehicles, %	2	2	2	2	2	2	2	2	2	2	2	2
Mvmt Flow	5	54	30	78	58	0	10	8	56	1	3	1

Major/Minor	Minor2		Minor1		Major1			Major2				
Conflicting Flow All	91	90	4	104	62	36	4	0	0	64	0	0
Stage 1	6	6	-	56	56	-	-	-	-	-	-	-
Stage 2	85	84	-	48	6	-	-	-	-	-	-	-
Critical Hdwy	7.12	6.52	6.22	7.12	6.52	6.22	4.12	-	-	4.12	-	-
Critical Hdwy Stg 1	6.12	5.52	-	6.12	5.52	-	-	-	-	-	-	-
Critical Hdwy Stg 2	6.12	5.52	-	6.12	5.52	-	-	-	-	-	-	-
Follow-up Hdwy	3.518	4.018	3.318	3.518	4.018	3.318	2.218	-	-	2.218	-	-
Pot Cap-1 Maneuver	893	800	1080	876	829	1037	1618	-	-	1538	-	-
Stage 1	1016	891	-	956	848	-	-	-	-	-	-	-
Stage 2	923	825	-	965	891	-	-	-	-	-	-	-
Platoon blocked, %								-	-	-	-	-
Mov Cap-1 Maneuver	840	794	1080	802	823	1037	1618	-	-	1538	-	-
Mov Cap-2 Maneuver	840	794	-	802	823	-	-	-	-	-	-	-
Stage 1	1010	890	-	950	843	-	-	-	-	-	-	-
Stage 2	854	820	-	880	890	-	-	-	-	-	-	-

Approach	EB		WB		NB		SB	
HCM Control Delay, s	9.6		10.3		1		1.8	
HCM LOS	A		B					

Minor Lane/Major Mvmt	NBL	NBT	NBR	EBLn1	WBLn1	SBL	SBT	SBR
Capacity (veh/h)	1618	-	-	875	811	1538	-	-
HCM Lane V/C Ratio	0.006	-	-	0.103	0.169	0.001	-	-
HCM Control Delay (s)	7.2	0	-	9.6	10.3	7.3	0	-
HCM Lane LOS	A	A	-	A	B	A	A	-
HCM 95th %tile Q(veh)	0	-	-	0.3	0.6	0	-	-

Heritage at Dalia Ranch
6: Imperial Ave & Worthington Rd/Barioni Blvd

Opening Year 2026
Timing Plan: AM PEAK

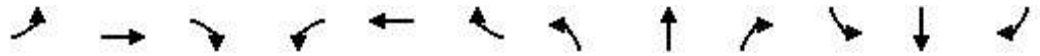

Movement	EBL	EBT	EBR	WBL	WBT	WBR	NBL	NBT	NBR	SBL	SBT	SBR
Lane Configurations		↕	↗		↕	↗	↗	↕↗		↗	↕↗	
Traffic Volume (veh/h)	78	142	221	57	137	80	96	508	53	41	724	71
Future Volume (veh/h)	78	142	221	57	137	80	96	508	53	41	724	71
Initial Q (Qb), veh	0	0	0	0	0	0	0	0	0	0	0	0
Ped-Bike Adj(A_pbT)	1.00		1.00	1.00		1.00	1.00		1.00	1.00		1.00
Parking Bus, Adj	1.00	1.00	1.00	1.00	1.00	1.00	1.00	1.00	1.00	1.00	1.00	1.00
Work Zone On Approach		No			No			No			No	
Adj Sat Flow, veh/h/ln	1870	1870	1870	1870	1870	1870	1870	1870	1870	1870	1870	1870
Adj Flow Rate, veh/h	88	160	248	64	154	90	108	571	60	46	813	80
Peak Hour Factor	0.89	0.89	0.89	0.89	0.89	0.89	0.89	0.89	0.89	0.89	0.89	0.89
Percent Heavy Veh, %	2	2	2	2	2	2	2	2	2	2	2	2
Cap, veh/h	128	233	312	85	204	248	132	998	105	76	903	89
Arrive On Green	0.20	0.20	0.20	0.16	0.16	0.16	0.07	0.31	0.31	0.04	0.28	0.28
Sat Flow, veh/h	652	1186	1585	541	1302	1585	1781	3246	340	1781	3268	322
Grp Volume(v), veh/h	248	0	248	218	0	90	108	312	319	46	442	451
Grp Sat Flow(s),veh/h/ln	1838	0	1585	1843	0	1585	1781	1777	1809	1781	1777	1812
Q Serve(g_s), s	8.5	0.0	10.1	7.6	0.0	3.4	4.0	10.0	10.0	1.7	16.2	16.2
Cycle Q Clear(g_c), s	8.5	0.0	10.1	7.6	0.0	3.4	4.0	10.0	10.0	1.7	16.2	16.2
Prop In Lane	0.35		1.00	0.29		1.00	1.00		0.19	1.00		0.18
Lane Grp Cap(c), veh/h	362	0	312	288	0	248	132	547	557	76	491	501
V/C Ratio(X)	0.69	0.00	0.79	0.76	0.00	0.36	0.82	0.57	0.57	0.60	0.90	0.90
Avail Cap(c_a), veh/h	490	0	423	492	0	423	132	547	557	132	500	510
HCM Platoon Ratio	1.00	1.00	1.00	1.00	1.00	1.00	1.00	1.00	1.00	1.00	1.00	1.00
Upstream Filter(l)	1.00	0.00	1.00	1.00	0.00	1.00	1.00	1.00	1.00	1.00	1.00	1.00
Uniform Delay (d), s/veh	25.2	0.0	25.8	27.2	0.0	25.5	30.8	19.6	19.6	31.7	23.5	23.5
Incr Delay (d2), s/veh	2.4	0.0	7.3	4.0	0.0	0.9	31.7	1.4	1.4	7.4	19.0	18.7
Initial Q Delay(d3),s/veh	0.0	0.0	0.0	0.0	0.0	0.0	0.0	0.0	0.0	0.0	0.0	0.0
%ile BackOfQ(50%),veh/ln	3.7	0.0	4.2	3.5	0.0	1.3	2.8	4.0	4.1	0.9	8.9	9.0
Unsig. Movement Delay, s/veh												
LnGrp Delay(d),s/veh	27.6	0.0	33.1	31.3	0.0	26.4	62.5	21.0	21.1	39.2	42.5	42.3
LnGrp LOS	C	A	C	C	A	C	E	C	C	D	D	D
Approach Vol, veh/h		496			308			739			939	
Approach Delay, s/veh		30.3			29.8			27.1			42.2	
Approach LOS		C			C			C			D	
Timer - Assigned Phs	1	2		4	5	6		8				
Phs Duration (G+Y+Rc), s	7.9	25.8		18.3	10.0	23.7		15.6				
Change Period (Y+Rc), s	5.0	5.0		5.0	5.0	5.0		5.0				
Max Green Setting (Gmax), s	5.0	19.0		18.0	5.0	19.0		18.0				
Max Q Clear Time (g_c+I1), s	3.7	12.0		12.1	6.0	18.2		9.6				
Green Ext Time (p_c), s	0.0	2.2		1.2	0.0	0.5		1.0				
Intersection Summary												
HCM 6th Ctrl Delay				33.8								
HCM 6th LOS				C								

Intersection

Intersection Delay, s/veh 22.5

Intersection LOS C

Movement	EBL	EBT	EBR	WBL	WBT	WBR	NBL	NBT	NBR	SBL	SBT	SBR
Lane Configurations		↔	↔		↔	↔		↔			↔	
Traffic Vol, veh/h	63	411	124	12	327	80	0	0	1	110	32	66
Future Vol, veh/h	63	411	124	12	327	80	0	0	1	110	32	66
Peak Hour Factor	0.92	0.92	0.92	0.92	0.92	0.92	0.92	0.92	0.92	0.92	0.92	0.92
Heavy Vehicles, %	2	2	2	2	2	2	2	2	2	2	2	2
Mvmt Flow	68	447	135	13	355	87	0	0	1	120	35	72
Number of Lanes	0	1	1	0	1	1	0	1	0	0	1	0

Approach	EB	WB	NB	SB
Opposing Approach	WB	EB	SB	NB
Opposing Lanes	2	2	1	1
Conflicting Approach Left	SB	NB	EB	WB
Conflicting Lanes Left	1	1	2	2
Conflicting Approach Right	NB	SB	WB	EB
Conflicting Lanes Right	1	1	2	2
HCM Control Delay	29.3	17.1	9.8	13.8
HCM LOS	D	C	A	B

Lane	NBLn1	EBLn1	EBLn2	WBLn1	WBLn2	SBLn1
Vol Left, %	0%	13%	0%	4%	0%	53%
Vol Thru, %	0%	87%	0%	96%	0%	15%
Vol Right, %	100%	0%	100%	0%	100%	32%
Sign Control	Stop	Stop	Stop	Stop	Stop	Stop
Traffic Vol by Lane	1	474	124	339	80	208
LT Vol	0	63	0	12	0	110
Through Vol	0	411	0	327	0	32
RT Vol	1	0	124	0	80	66
Lane Flow Rate	1	515	135	368	87	226
Geometry Grp	2	7	7	7	7	2
Degree of Util (X)	0.002	0.857	0.195	0.631	0.131	0.403
Departure Headway (Hd)	6.795	5.987	5.209	6.167	5.437	6.416
Convergence, Y/N	Yes	Yes	Yes	Yes	Yes	Yes
Cap	530	603	687	582	657	558
Service Time	4.795	3.735	2.957	3.924	3.194	4.475
HCM Lane V/C Ratio	0.002	0.854	0.197	0.632	0.132	0.405
HCM Control Delay	9.8	34.5	9.2	19	9	13.8
HCM Lane LOS	A	D	A	C	A	B
HCM 95th-tile Q	0	9.5	0.7	4.4	0.4	1.9

Heritage at Dalia Ranch
8: Imperial Ave & Aten Rd



















Opening Year 2026
Timing Plan: AM PEAK



Movement	EBL	EBT	EBR	WBL	WBT	WBR	NBL	NBT	NBR	SBL	SBT	SBR
Lane Configurations												
Traffic Volume (veh/h)	199	352	65	136	312	147	63	376	70	148	753	404
Future Volume (veh/h)	199	352	65	136	312	147	63	376	70	148	753	404
Initial Q (Qb), veh	0	0	0	0	0	0	0	0	0	0	0	0
Ped-Bike Adj(A_pbT)	1.00		1.00	1.00		1.00	1.00		1.00	1.00		1.00
Parking Bus, Adj	1.00	1.00	1.00	1.00	1.00	1.00	1.00	1.00	1.00	1.00	1.00	1.00
Work Zone On Approach		No			No			No			No	
Adj Sat Flow, veh/h/ln	1870	1870	1870	1870	1870	1870	1870	1870	1870	1870	1870	1870
Adj Flow Rate, veh/h	231	409	76	158	363	171	73	437	81	172	876	470
Peak Hour Factor	0.86	0.86	0.86	0.86	0.86	0.86	0.86	0.86	0.86	0.86	0.86	0.86
Percent Heavy Veh, %	2	2	2	2	2	2	2	2	2	2	2	2
Cap, veh/h	273	729	134	197	473	219	97	860	384	206	1077	480
Arrive On Green	0.15	0.24	0.24	0.11	0.20	0.20	0.05	0.24	0.24	0.12	0.30	0.30
Sat Flow, veh/h	1781	2996	552	1781	2358	1093	1781	3554	1585	1781	3554	1585
Grp Volume(v), veh/h	231	241	244	158	272	262	73	437	81	172	876	470
Grp Sat Flow(s),veh/h/ln	1781	1777	1771	1781	1777	1674	1781	1777	1585	1781	1777	1585
Q Serve(g_s), s	8.7	8.2	8.4	6.0	10.0	10.3	2.8	7.4	2.8	6.6	15.8	20.4
Cycle Q Clear(g_c), s	8.7	8.2	8.4	6.0	10.0	10.3	2.8	7.4	2.8	6.6	15.8	20.4
Prop In Lane	1.00		0.31	1.00		0.65	1.00		1.00	1.00		1.00
Lane Grp Cap(c), veh/h	273	433	431	197	356	336	97	860	384	206	1077	480
V/C Ratio(X)	0.85	0.56	0.57	0.80	0.76	0.78	0.75	0.51	0.21	0.84	0.81	0.98
Avail Cap(c_a), veh/h	283	513	511	231	461	435	129	923	412	206	1077	480
HCM Platoon Ratio	1.00	1.00	1.00	1.00	1.00	1.00	1.00	1.00	1.00	1.00	1.00	1.00
Upstream Filter(l)	1.00	1.00	1.00	1.00	1.00	1.00	1.00	1.00	1.00	1.00	1.00	1.00
Uniform Delay (d), s/veh	28.5	22.9	23.0	30.1	26.2	26.3	32.3	22.7	21.0	30.0	22.3	23.9
Incr Delay (d2), s/veh	19.9	1.1	1.2	15.9	5.5	6.7	15.9	0.5	0.3	24.9	4.9	35.4
Initial Q Delay(d3),s/veh	0.0	0.0	0.0	0.0	0.0	0.0	0.0	0.0	0.0	0.0	0.0	0.0
%ile BackOfQ(50%),veh/ln	5.1	3.4	3.4	3.3	4.6	4.5	1.6	3.0	1.0	4.1	6.9	11.7
Unsig. Movement Delay, s/veh												
LnGrp Delay(d),s/veh	48.5	24.1	24.2	46.0	31.7	33.0	48.3	23.2	21.3	54.9	27.2	59.3
LnGrp LOS	D	C	C	D	C	C	D	C	C	D	C	E
Approach Vol, veh/h		716			692			591			1518	
Approach Delay, s/veh		32.0			35.4			26.0			40.3	
Approach LOS		C			D			C			D	
Timer - Assigned Phs	1	2	3	4	5	6	7	8				
Phs Duration (G+Y+Rc), s	3.0	21.8	12.7	21.9	8.8	26.0	15.6	18.9				
Change Period (Y+Rc), s	5.0	5.0	5.0	5.0	5.0	5.0	5.0	5.0				
Max Green Setting (Gmax), s	3.0	18.0	9.0	20.0	5.0	21.0	11.0	18.0				
Max Q Clear Time (g_c+1/6), s	3.0	9.4	8.0	10.4	4.8	22.4	10.7	12.3				
Green Ext Time (p_c), s	0.0	2.0	0.0	2.0	0.0	0.0	0.0	1.6				
Intersection Summary												
HCM 6th Ctrl Delay											35.2	
HCM 6th LOS											D	

Heritage at Dalia Ranch
1: SR-86 & Keystone Rd

Opening Year 2026
Timing Plan: PM PEAK

												
Movement	EBL	EBT	EBR	WBL	WBT	WBR	NBL	NBT	NBR	SBL	SBT	SBR
Lane Configurations												
Traffic Volume (veh/h)	43	13	20	34	28	39	11	564	27	55	595	35
Future Volume (veh/h)	43	13	20	34	28	39	11	564	27	55	595	35
Initial Q (Qb), veh	0	0	0	0	0	0	0	0	0	0	0	0
Ped-Bike Adj(A_pbT)	1.00		1.00	1.00		1.00	1.00		1.00	1.00		1.00
Parking Bus, Adj	1.00	1.00	1.00	1.00	1.00	1.00	1.00	1.00	1.00	1.00	1.00	1.00
Work Zone On Approach		No			No			No			No	
Adj Sat Flow, veh/h/ln	1870	1870	1870	1870	1870	1870	1870	1870	1870	1870	1870	1870
Adj Flow Rate, veh/h	48	15	22	38	31	44	12	634	30	62	669	39
Peak Hour Factor	0.89	0.89	0.89	0.89	0.89	0.89	0.89	0.89	0.89	0.89	0.89	0.89
Percent Heavy Veh, %	2	2	2	2	2	2	2	2	2	2	2	2
Cap, veh/h	281	53	55	211	71	83	28	1171	522	118	1351	603
Arrive On Green	0.13	0.13	0.13	0.13	0.13	0.13	0.02	0.33	0.33	0.07	0.38	0.38
Sat Flow, veh/h	795	409	421	456	547	640	1781	3554	1585	1781	3554	1585
Grp Volume(v), veh/h	85	0	0	113	0	0	12	634	30	62	669	39
Grp Sat Flow(s),veh/h/ln	1625	0	0	1643	0	0	1781	1777	1585	1781	1777	1585
Q Serve(g_s), s	0.0	0.0	0.0	0.6	0.0	0.0	0.2	4.6	0.4	1.1	4.6	0.5
Cycle Q Clear(g_c), s	1.4	0.0	0.0	1.9	0.0	0.0	0.2	4.6	0.4	1.1	4.6	0.5
Prop In Lane	0.56		0.26	0.34		0.39	1.00		1.00	1.00		1.00
Lane Grp Cap(c), veh/h	390	0	0	366	0	0	28	1171	522	118	1351	603
V/C Ratio(X)	0.22	0.00	0.00	0.31	0.00	0.00	0.43	0.54	0.06	0.52	0.50	0.06
Avail Cap(c_a), veh/h	1030	0	0	1053	0	0	281	2357	1051	338	2469	1101
HCM Platoon Ratio	1.00	1.00	1.00	1.00	1.00	1.00	1.00	1.00	1.00	1.00	1.00	1.00
Upstream Filter(l)	1.00	0.00	0.00	1.00	0.00	0.00	1.00	1.00	1.00	1.00	1.00	1.00
Uniform Delay (d), s/veh	12.6	0.0	0.0	12.8	0.0	0.0	15.4	8.7	7.3	14.3	7.5	6.2
Incr Delay (d2), s/veh	0.3	0.0	0.0	0.5	0.0	0.0	9.9	0.4	0.0	3.6	0.3	0.0
Initial Q Delay(d3),s/veh	0.0	0.0	0.0	0.0	0.0	0.0	0.0	0.0	0.0	0.0	0.0	0.0
%ile BackOfQ(50%),veh/ln	0.5	0.0	0.0	0.6	0.0	0.0	0.1	1.2	0.1	0.5	1.1	0.1
Unsig. Movement Delay, s/veh												
LnGrp Delay(d),s/veh	12.8	0.0	0.0	13.3	0.0	0.0	25.3	9.1	7.3	17.9	7.8	6.3
LnGrp LOS	B	A	A	B	A	A	C	A	A	B	A	A
Approach Vol, veh/h		85			113			676			770	
Approach Delay, s/veh		12.8			13.3			9.3			8.5	
Approach LOS		B			B			A			A	
Timer - Assigned Phs	1	2		4	5	6		8				
Phs Duration (G+Y+Rc), s	7.1	15.4		9.1	5.5	17.0		9.1				
Change Period (Y+Rc), s	5.0	5.0		5.0	5.0	5.0		5.0				
Max Green Setting (Gmax), s	6.0	21.0		18.0	5.0	22.0		18.0				
Max Q Clear Time (g_c+I1), s	3.1	6.6		3.4	2.2	6.6		3.9				
Green Ext Time (p_c), s	0.0	3.8		0.3	0.0	4.2		0.4				
Intersection Summary												
HCM 6th Ctrl Delay				9.4								
HCM 6th LOS				A								

Intersection												
Int Delay, s/veh	0.3											
Movement	EBL	EBT	EBR	WBL	WBT	WBR	NBL	NBT	NBR	SBL	SBT	SBR
Lane Configurations		↕			↕		↕	↕		↕	↕	
Traffic Vol, veh/h	6	4	0	8	0	5	1	603	8	6	632	18
Future Vol, veh/h	6	4	0	8	0	5	1	603	8	6	632	18
Conflicting Peds, #/hr	0	0	0	0	0	0	0	0	0	0	0	0
Sign Control	Stop	Stop	Stop	Stop	Stop	Stop	Free	Free	Free	Free	Free	Free
RT Channelized	-	-	None	-	-	None	-	-	None	-	-	None
Storage Length	-	-	-	-	-	-	50	-	-	50	-	-
Veh in Median Storage, #	-	1	-	-	1	-	-	0	-	-	0	-
Grade, %	-	0	-	-	0	-	-	0	-	-	0	-
Peak Hour Factor	92	92	92	92	92	92	92	92	92	92	92	92
Heavy Vehicles, %	2	2	2	2	2	2	2	2	2	2	2	2
Mvmt Flow	7	4	0	9	0	5	1	655	9	7	687	20

Major/Minor	Minor2		Minor1		Major1		Major2					
Conflicting Flow All	1041	1377	354	1022	1383	332	707	0	0	664	0	0
Stage 1	711	711	-	662	662	-	-	-	-	-	-	-
Stage 2	330	666	-	360	721	-	-	-	-	-	-	-
Critical Hdwy	7.54	6.54	6.94	7.54	6.54	6.94	4.14	-	-	4.14	-	-
Critical Hdwy Stg 1	6.54	5.54	-	6.54	5.54	-	-	-	-	-	-	-
Critical Hdwy Stg 2	6.54	5.54	-	6.54	5.54	-	-	-	-	-	-	-
Follow-up Hdwy	3.52	4.02	3.32	3.52	4.02	3.32	2.22	-	-	2.22	-	-
Pot Cap-1 Maneuver	184	144	642	190	143	664	887	-	-	921	-	-
Stage 1	390	434	-	417	457	-	-	-	-	-	-	-
Stage 2	657	456	-	631	430	-	-	-	-	-	-	-
Platoon blocked, %								-	-	-	-	-
Mov Cap-1 Maneuver	181	143	642	186	142	664	887	-	-	921	-	-
Mov Cap-2 Maneuver	297	266	-	307	266	-	-	-	-	-	-	-
Stage 1	390	431	-	417	457	-	-	-	-	-	-	-
Stage 2	651	456	-	620	427	-	-	-	-	-	-	-

Approach	EB		WB		NB		SB			
HCM Control Delay, s	18.2		14.7		0		0.1			
HCM LOS	C		B							

Minor Lane/Major Mvmt	NBL	NBT	NBR	EBLn1	WBLn1	SBL	SBT	SBR
Capacity (veh/h)	887	-	-	284	387	921	-	-
HCM Lane V/C Ratio	0.001	-	-	0.038	0.037	0.007	-	-
HCM Control Delay (s)	9.1	-	-	18.2	14.7	8.9	-	-
HCM Lane LOS	A	-	-	C	B	A	-	-
HCM 95th %tile Q(veh)	0	-	-	0.1	0.1	0	-	-

Intersection						
Int Delay, s/veh	0.7					
Movement	WBL	WBR	NBT	NBR	SBL	SBT
Lane Configurations	↔		↑↑		↔	↑↑
Traffic Vol, veh/h	20	11	604	31	31	595
Future Vol, veh/h	20	11	604	31	31	595
Conflicting Peds, #/hr	0	0	0	0	0	0
Sign Control	Stop	Stop	Free	Free	Free	Free
RT Channelized	-	None	-	None	-	None
Storage Length	0	-	-	-	140	-
Veh in Median Storage, #	0	-	0	-	-	0
Grade, %	0	-	0	-	-	0
Peak Hour Factor	91	91	91	91	91	91
Heavy Vehicles, %	2	2	2	2	2	2
Mvmt Flow	22	12	664	34	34	654

Major/Minor	Minor1	Major1	Major2		
Conflicting Flow All	1076	349	0	0	698
Stage 1	681	-	-	-	-
Stage 2	395	-	-	-	-
Critical Hdwy	6.84	6.94	-	-	4.14
Critical Hdwy Stg 1	5.84	-	-	-	-
Critical Hdwy Stg 2	5.84	-	-	-	-
Follow-up Hdwy	3.52	3.32	-	-	2.22
Pot Cap-1 Maneuver	214	647	-	-	894
Stage 1	464	-	-	-	-
Stage 2	650	-	-	-	-
Platoon blocked, %			-	-	-
Mov Cap-1 Maneuver	206	647	-	-	894
Mov Cap-2 Maneuver	206	-	-	-	-
Stage 1	464	-	-	-	-
Stage 2	625	-	-	-	-

Approach	WB	NB	SB
HCM Control Delay, s	20.1	0	0.5
HCM LOS	C		

Minor Lane/Major Mvmt	NBT	NBRWBLn1	SBL	SBT
Capacity (veh/h)	-	-	272	894
HCM Lane V/C Ratio	-	-	0.125	0.038
HCM Control Delay (s)	-	-	20.1	9.2
HCM Lane LOS	-	-	C	A
HCM 95th %tile Q(veh)	-	-	0.4	0.1

Heritage at Dalia Ranch
4: Imperial Ave & Neckel Rd

Opening Year 2026
Timing Plan: PM PEAK

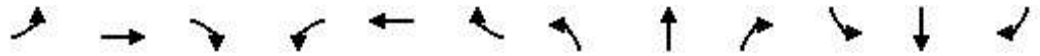

Movement	EBL	EBT	EBR	WBL	WBT	WBR	NBL	NBT	NBR	SBL	SBT	SBR
Lane Configurations		↕			↕		↕	↕		↕	↕	
Traffic Volume (veh/h)	13	27	4	139	20	66	12	579	178	60	517	29
Future Volume (veh/h)	13	27	4	139	20	66	12	579	178	60	517	29
Initial Q (Qb), veh	0	0	0	0	0	0	0	0	0	0	0	0
Ped-Bike Adj(A_pbT)	1.00		1.00	1.00		1.00	1.00		1.00	1.00		1.00
Parking Bus, Adj	1.00	1.00	1.00	1.00	1.00	1.00	1.00	1.00	1.00	1.00	1.00	1.00
Work Zone On Approach		No			No			No			No	
Adj Sat Flow, veh/h/ln	1870	1870	1870	1870	1870	1870	1870	1870	1870	1870	1870	1870
Adj Flow Rate, veh/h	14	29	4	151	22	72	13	629	193	65	562	32
Peak Hour Factor	0.92	0.92	0.92	0.92	0.92	0.92	0.92	0.92	0.92	0.92	0.92	0.92
Percent Heavy Veh, %	2	2	2	2	2	2	2	2	2	2	2	2
Cap, veh/h	26	54	7	198	29	95	29	824	252	106	1197	68
Arrive On Green	0.05	0.05	0.05	0.19	0.19	0.19	0.02	0.31	0.31	0.06	0.35	0.35
Sat Flow, veh/h	541	1120	155	1064	155	507	1781	2679	821	1781	3418	194
Grp Volume(v), veh/h	47	0	0	245	0	0	13	417	405	65	292	302
Grp Sat Flow(s),veh/h/ln	1816	0	0	1726	0	0	1781	1777	1723	1781	1777	1835
Q Serve(g_s), s	1.3	0.0	0.0	6.8	0.0	0.0	0.4	10.7	10.7	1.8	6.4	6.4
Cycle Q Clear(g_c), s	1.3	0.0	0.0	6.8	0.0	0.0	0.4	10.7	10.7	1.8	6.4	6.4
Prop In Lane	0.30		0.09	0.62		0.29	1.00		0.48	1.00		0.11
Lane Grp Cap(c), veh/h	87	0	0	322	0	0	29	546	530	106	622	643
V/C Ratio(X)	0.54	0.00	0.00	0.76	0.00	0.00	0.44	0.76	0.76	0.61	0.47	0.47
Avail Cap(c_a), veh/h	651	0	0	619	0	0	178	673	652	178	673	695
HCM Platoon Ratio	1.00	1.00	1.00	1.00	1.00	1.00	1.00	1.00	1.00	1.00	1.00	1.00
Upstream Filter(I)	1.00	0.00	0.00	1.00	0.00	0.00	1.00	1.00	1.00	1.00	1.00	1.00
Uniform Delay (d), s/veh	23.3	0.0	0.0	19.3	0.0	0.0	24.4	15.7	15.7	23.0	12.7	12.7
Incr Delay (d2), s/veh	5.1	0.0	0.0	3.7	0.0	0.0	10.1	4.1	4.3	5.7	0.5	0.5
Initial Q Delay(d3),s/veh	0.0	0.0	0.0	0.0	0.0	0.0	0.0	0.0	0.0	0.0	0.0	0.0
%ile BackOfQ(50%),veh/ln	0.6	0.0	0.0	2.7	0.0	0.0	0.2	4.3	4.2	0.9	2.2	2.3
Unsig. Movement Delay, s/veh												
LnGrp Delay(d),s/veh	28.5	0.0	0.0	23.1	0.0	0.0	34.5	19.8	20.0	28.7	13.2	13.2
LnGrp LOS	C	A	A	C	A	A	C	B	C	C	B	B
Approach Vol, veh/h		47			245			835				659
Approach Delay, s/veh		28.5			23.1			20.2				14.7
Approach LOS		C			C			C				B
Timer - Assigned Phs	1	2		4	5	6		8				
Phs Duration (G+Y+Rc), s	8.0	20.4		7.4	5.8	22.6		14.4				
Change Period (Y+Rc), s	5.0	5.0		5.0	5.0	5.0		5.0				
Max Green Setting (Gmax), s	5.0	19.0		18.0	5.0	19.0		18.0				
Max Q Clear Time (g_c+I1), s	3.8	12.7		3.3	2.4	8.4		8.8				
Green Ext Time (p_c), s	0.0	2.7		0.1	0.0	2.7		0.9				
Intersection Summary												
HCM 6th Ctrl Delay				18.8								
HCM 6th LOS				B								

Intersection												
Int Delay, s/veh	7.7											
Movement	EBL	EBT	EBR	WBL	WBT	WBR	NBL	NBT	NBR	SBL	SBT	SBR
Lane Configurations		↕			↕			↕			↕	
Traffic Vol, veh/h	2	40	9	24	46	1	5	6	11	0	5	8
Future Vol, veh/h	2	40	9	24	46	1	5	6	11	0	5	8
Conflicting Peds, #/hr	0	0	0	0	0	0	0	0	0	0	0	0
Sign Control	Stop	Stop	Stop	Stop	Stop	Stop	Free	Free	Free	Free	Free	Free
RT Channelized	-	-	None	-	-	None	-	-	None	-	-	None
Storage Length	-	-	-	-	-	-	-	-	-	-	-	-
Veh in Median Storage, #	-	0	-	-	0	-	-	0	-	-	0	-
Grade, %	-	0	-	-	0	-	-	0	-	-	0	-
Peak Hour Factor	79	79	79	79	79	79	79	79	79	79	79	79
Heavy Vehicles, %	2	2	2	2	2	2	2	2	2	2	2	2
Mvmt Flow	3	51	11	30	58	1	6	8	14	0	6	10

Major/Minor	Minor2		Minor1		Major1		Major2					
Conflicting Flow All	68	45	11	69	43	15	16	0	0	22	0	0
Stage 1	11	11	-	27	27	-	-	-	-	-	-	-
Stage 2	57	34	-	42	16	-	-	-	-	-	-	-
Critical Hdwy	7.12	6.52	6.22	7.12	6.52	6.22	4.12	-	-	4.12	-	-
Critical Hdwy Stg 1	6.12	5.52	-	6.12	5.52	-	-	-	-	-	-	-
Critical Hdwy Stg 2	6.12	5.52	-	6.12	5.52	-	-	-	-	-	-	-
Follow-up Hdwy	3.518	4.018	3.318	3.518	4.018	3.318	2.218	-	-	2.218	-	-
Pot Cap-1 Maneuver	925	847	1070	923	849	1065	1602	-	-	1593	-	-
Stage 1	1010	886	-	990	873	-	-	-	-	-	-	-
Stage 2	955	867	-	972	882	-	-	-	-	-	-	-
Platoon blocked, %								-	-	-	-	-
Mov Cap-1 Maneuver	872	844	1070	869	846	1065	1602	-	-	1593	-	-
Mov Cap-2 Maneuver	872	844	-	869	846	-	-	-	-	-	-	-
Stage 1	1006	886	-	986	870	-	-	-	-	-	-	-
Stage 2	886	864	-	907	882	-	-	-	-	-	-	-

Approach	EB		WB		NB		SB	
HCM Control Delay, s	9.4		9.7		1.6		0	
HCM LOS	A		A					

Minor Lane/Major Mvmt	NBL	NBT	NBR	EBLn1	WBLn1	SBL	SBT	SBR
Capacity (veh/h)	1602	-	-	878	856	1593	-	-
HCM Lane V/C Ratio	0.004	-	-	0.074	0.105	-	-	-
HCM Control Delay (s)	7.3	0	-	9.4	9.7	0	-	-
HCM Lane LOS	A	A	-	A	A	A	-	-
HCM 95th %tile Q(veh)	0	-	-	0.2	0.4	0	-	-

Heritage at Dalia Ranch
6: Imperial Ave & Worthington Rd/Barioni Blvd

Opening Year 2026
Timing Plan: PM PEAK

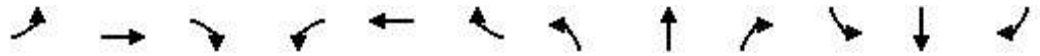

Movement	EBL	EBT	EBR	WBL	WBT	WBR	NBL	NBT	NBR	SBL	SBT	SBR
Lane Configurations		↕	↗		↕	↗	↖	↕↗		↖	↕↗	
Traffic Volume (veh/h)	65	77	109	57	117	54	117	771	15	28	663	74
Future Volume (veh/h)	65	77	109	57	117	54	117	771	15	28	663	74
Initial Q (Qb), veh	0	0	0	0	0	0	0	0	0	0	0	0
Ped-Bike Adj(A_pbT)	1.00		1.00	1.00		1.00	1.00		1.00	1.00		1.00
Parking Bus, Adj	1.00	1.00	1.00	1.00	1.00	1.00	1.00	1.00	1.00	1.00	1.00	1.00
Work Zone On Approach		No			No			No			No	
Adj Sat Flow, veh/h/ln	1870	1870	1870	1870	1870	1870	1870	1870	1870	1870	1870	1870
Adj Flow Rate, veh/h	71	85	120	63	129	59	129	847	16	31	729	81
Peak Hour Factor	0.91	0.91	0.91	0.91	0.91	0.91	0.91	0.91	0.91	0.91	0.91	0.91
Percent Heavy Veh, %	2	2	2	2	2	2	2	2	2	2	2	2
Cap, veh/h	109	130	207	89	182	233	164	1202	23	61	898	100
Arrive On Green	0.13	0.13	0.13	0.15	0.15	0.15	0.09	0.34	0.34	0.03	0.28	0.28
Sat Flow, veh/h	832	996	1585	604	1236	1585	1781	3568	67	1781	3225	358
Grp Volume(v), veh/h	156	0	120	192	0	59	129	422	441	31	402	408
Grp Sat Flow(s),veh/h/ln	1829	0	1585	1840	0	1585	1781	1777	1858	1781	1777	1806
Q Serve(g_s), s	4.6	0.0	4.1	5.7	0.0	1.9	4.0	11.8	11.8	1.0	12.0	12.0
Cycle Q Clear(g_c), s	4.6	0.0	4.1	5.7	0.0	1.9	4.0	11.8	11.8	1.0	12.0	12.0
Prop In Lane	0.46		1.00	0.33		1.00	1.00		0.04	1.00		0.20
Lane Grp Cap(c), veh/h	239	0	207	270	0	233	164	598	626	61	495	503
V/C Ratio(X)	0.65	0.00	0.58	0.71	0.00	0.25	0.79	0.70	0.70	0.51	0.81	0.81
Avail Cap(c_a), veh/h	578	0	501	582	0	501	188	598	626	156	562	571
HCM Platoon Ratio	1.00	1.00	1.00	1.00	1.00	1.00	1.00	1.00	1.00	1.00	1.00	1.00
Upstream Filter(I)	1.00	0.00	1.00	1.00	0.00	1.00	1.00	1.00	1.00	1.00	1.00	1.00
Uniform Delay (d), s/veh	23.5	0.0	23.3	23.1	0.0	21.5	25.3	16.4	16.4	27.0	19.1	19.1
Incr Delay (d2), s/veh	3.0	0.0	2.5	3.4	0.0	0.6	17.3	3.8	3.6	6.5	7.9	7.8
Initial Q Delay(d3),s/veh	0.0	0.0	0.0	0.0	0.0	0.0	0.0	0.0	0.0	0.0	0.0	0.0
%ile BackOfQ(50%),veh/ln	2.0	0.0	1.5	2.5	0.0	0.7	2.4	4.8	5.0	0.5	5.5	5.6
Unsig. Movement Delay, s/veh												
LnGrp Delay(d),s/veh	26.5	0.0	25.8	26.6	0.0	22.1	42.6	20.2	20.0	33.6	27.0	27.0
LnGrp LOS	C	A	C	C	A	C	D	C	C	C	C	C
Approach Vol, veh/h		276			251			992			841	
Approach Delay, s/veh		26.2			25.5			23.0			27.2	
Approach LOS		C			C			C			C	
Timer - Assigned Phs	1	2		4	5	6		8				
Phs Duration (G+Y+Rc), s	6.9	24.2		12.5	10.3	20.9		13.4				
Change Period (Y+Rc), s	5.0	5.0		5.0	5.0	5.0		5.0				
Max Green Setting (Gmax), s	5.0	19.0		18.0	6.0	18.0		18.0				
Max Q Clear Time (g_c+I1), s	3.0	13.8		6.6	6.0	14.0		7.7				
Green Ext Time (p_c), s	0.0	2.5		0.9	0.0	1.9		0.9				
Intersection Summary												
HCM 6th Ctrl Delay			25.2									
HCM 6th LOS			C									

Intersection

Intersection Delay, s/veh 11.1

Intersection LOS B

Movement	EBL	EBT	EBR	WBL	WBT	WBR	NBL	NBT	NBR	SBL	SBT	SBR
Lane Configurations		↔	↔		↔	↔		↔			↔	
Traffic Vol, veh/h	27	210	34	28	233	35	1	0	0	39	5	25
Future Vol, veh/h	27	210	34	28	233	35	1	0	0	39	5	25
Peak Hour Factor	0.80	0.80	0.80	0.80	0.80	0.80	0.80	0.80	0.80	0.80	0.80	0.80
Heavy Vehicles, %	2	2	2	2	2	2	2	2	2	2	2	2
Mvmt Flow	34	263	43	35	291	44	1	0	0	49	6	31
Number of Lanes	0	1	1	0	1	1	0	1	0	0	1	0

Approach	EB	WB	NB	SB
Opposing Approach	WB	EB	SB	NB
Opposing Lanes	2	2	1	1
Conflicting Approach Left	SB	NB	EB	WB
Conflicting Lanes Left	1	1	2	2
Conflicting Approach Right	NB	SB	WB	EB
Conflicting Lanes Right	1	1	2	2
HCM Control Delay	11.1	11.6	9	9.3
HCM LOS	B	B	A	A

Lane	NBLn1	EBLn1	EBLn2	WBLn1	WBLn2	SBLn1
Vol Left, %	100%	11%	0%	11%	0%	57%
Vol Thru, %	0%	89%	0%	89%	0%	7%
Vol Right, %	0%	0%	100%	0%	100%	36%
Sign Control	Stop	Stop	Stop	Stop	Stop	Stop
Traffic Vol by Lane	1	237	34	261	35	69
LT Vol	1	27	0	28	0	39
Through Vol	0	210	0	233	0	5
RT Vol	0	0	34	0	35	25
Lane Flow Rate	1	296	42	326	44	86
Geometry Grp	2	7	7	7	7	2
Degree of Util (X)	0.002	0.423	0.052	0.464	0.053	0.13
Departure Headway (Hd)	5.921	5.145	4.384	5.115	4.357	5.445
Convergence, Y/N	Yes	Yes	Yes	Yes	Yes	Yes
Cap	600	699	814	705	819	655
Service Time	4	2.886	2.125	2.856	2.097	3.502
HCM Lane V/C Ratio	0.002	0.423	0.052	0.462	0.054	0.131
HCM Control Delay	9	11.6	7.4	12.2	7.3	9.3
HCM Lane LOS	A	B	A	B	A	A
HCM 95th-tile Q	0	2.1	0.2	2.5	0.2	0.4

Heritage at Dalia Ranch
8: Imperial Ave & Aten Rd

Opening Year 2026
Timing Plan: PM PEAK



Movement	EBL	EBT	EBR	WBL	WBT	WBR	NBL	NBT	NBR	SBL	SBT	SBR
Lane Configurations												
Traffic Volume (veh/h)	212	287	71	185	300	128	81	753	155	117	596	227
Future Volume (veh/h)	212	287	71	185	300	128	81	753	155	117	596	227
Initial Q (Qb), veh	0	0	0	0	0	0	0	0	0	0	0	0
Ped-Bike Adj(A_pbT)	1.00		1.00	1.00		1.00	1.00		1.00	1.00		1.00
Parking Bus, Adj	1.00	1.00	1.00	1.00	1.00	1.00	1.00	1.00	1.00	1.00	1.00	1.00
Work Zone On Approach		No		No		No		No		No		No
Adj Sat Flow, veh/h/ln	1870	1870	1870	1870	1870	1870	1870	1870	1870	1870	1870	1870
Adj Flow Rate, veh/h	226	305	76	197	319	136	86	801	165	124	634	241
Peak Hour Factor	0.94	0.94	0.94	0.94	0.94	0.94	0.94	0.94	0.94	0.94	0.94	0.94
Percent Heavy Veh, %	2	2	2	2	2	2	2	2	2	2	2	2
Cap, veh/h	271	562	138	242	445	186	110	960	428	158	1055	470
Arrive On Green	0.15	0.20	0.20	0.14	0.18	0.18	0.06	0.27	0.27	0.09	0.30	0.30
Sat Flow, veh/h	1781	2828	694	1781	2443	1020	1781	3554	1585	1781	3554	1585
Grp Volume(v), veh/h	226	190	191	197	230	225	86	801	165	124	634	241
Grp Sat Flow(s),veh/h/ln	1781	1777	1745	1781	1777	1687	1781	1777	1585	1781	1777	1585
Q Serve(g_s), s	8.0	6.2	6.4	7.0	7.9	8.2	3.1	13.8	5.5	4.4	10.0	8.2
Cycle Q Clear(g_c), s	8.0	6.2	6.4	7.0	7.9	8.2	3.1	13.8	5.5	4.4	10.0	8.2
Prop In Lane	1.00		0.40	1.00		0.61	1.00		1.00	1.00		1.00
Lane Grp Cap(c), veh/h	271	353	347	242	324	307	110	960	428	158	1055	470
V/C Ratio(X)	0.83	0.54	0.55	0.81	0.71	0.73	0.78	0.83	0.39	0.79	0.60	0.51
Avail Cap(c_a), veh/h	301	491	482	301	491	466	164	1036	462	191	1090	486
HCM Platoon Ratio	1.00	1.00	1.00	1.00	1.00	1.00	1.00	1.00	1.00	1.00	1.00	1.00
Upstream Filter(l)	1.00	1.00	1.00	1.00	1.00	1.00	1.00	1.00	1.00	1.00	1.00	1.00
Uniform Delay (d), s/veh	26.8	23.4	23.5	27.4	25.0	25.1	30.1	22.4	19.4	29.1	19.6	19.0
Incr Delay (d2), s/veh	16.6	1.3	1.4	13.0	2.9	3.4	13.0	5.7	0.6	16.1	0.9	0.9
Initial Q Delay(d3),s/veh	0.0	0.0	0.0	0.0	0.0	0.0	0.0	0.0	0.0	0.0	0.0	0.0
%ile BackOfQ(50%),veh/ln	4.5	2.6	2.6	3.7	3.4	3.4	1.7	6.1	2.0	2.5	3.9	2.9
Unsig. Movement Delay, s/veh												
LnGrp Delay(d),s/veh	43.4	24.7	24.9	40.3	27.9	28.5	43.1	28.1	19.9	45.2	20.5	19.9
LnGrp LOS	D	C	C	D	C	C	D	C	B	D	C	B
Approach Vol, veh/h		607			652			1052			999	
Approach Delay, s/veh		31.7			31.9			28.0			23.4	
Approach LOS		C			C			C			C	
Timer - Assigned Phs	1	2	3	4	5	6	7	8				
Phs Duration (G+Y+Rc), s	0.8	22.6	13.9	17.9	9.0	24.3	14.9	16.9				
Change Period (Y+Rc), s	5.0	5.0	5.0	5.0	5.0	5.0	5.0	5.0				
Max Green Setting (Gmax), s	19.0	11.0	18.0	6.0	20.0	11.0	18.0					
Max Q Clear Time (g_c+1/4), s	15.8	9.0	8.4	5.1	12.0	10.0	10.2					
Green Ext Time (p_c), s	0.0	1.8	0.1	1.5	0.0	3.2	0.1	1.7				

Intersection Summary

HCM 6th Ctrl Delay	28.1
HCM 6th LOS	C

Heritage at Dalia Ranch
1: SR-86 & Keystone Rd

Opening Year 2026 + P1-3 Proj
Timing Plan: AM PEAK

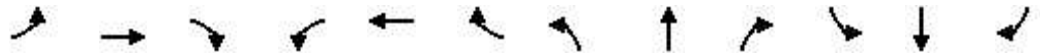

Movement	EBL	EBT	EBR	WBL	WBT	WBR	NBL	NBT	NBR	SBL	SBT	SBR
Lane Configurations		↔			↔		↗	↕	↗	↗	↕	↗
Traffic Volume (veh/h)	34	34	12	19	25	44	19	545	51	47	591	39
Future Volume (veh/h)	34	34	12	19	25	44	19	545	51	47	591	39
Initial Q (Qb), veh	0	0	0	0	0	0	0	0	0	0	0	0
Ped-Bike Adj(A_pbT)	1.00		1.00	1.00		1.00	1.00		1.00	1.00		1.00
Parking Bus, Adj	1.00	1.00	1.00	1.00	1.00	1.00	1.00	1.00	1.00	1.00	1.00	1.00
Work Zone On Approach		No			No			No			No	
Adj Sat Flow, veh/h/ln	1870	1870	1870	1870	1870	1870	1870	1870	1870	1870	1870	1870
Adj Flow Rate, veh/h	38	38	13	21	28	49	21	606	57	52	657	43
Peak Hour Factor	0.90	0.90	0.90	0.90	0.90	0.90	0.90	0.90	0.90	0.90	0.90	0.90
Percent Heavy Veh, %	2	2	2	2	2	2	2	2	2	2	2	2
Cap, veh/h	247	108	32	178	73	108	48	1126	502	104	1239	552
Arrive On Green	0.13	0.13	0.13	0.13	0.13	0.13	0.03	0.32	0.32	0.06	0.35	0.35
Sat Flow, veh/h	592	829	243	264	561	825	1781	3554	1585	1781	3554	1585
Grp Volume(v), veh/h	89	0	0	98	0	0	21	606	57	52	657	43
Grp Sat Flow(s),veh/h/ln	1664	0	0	1650	0	0	1781	1777	1585	1781	1777	1585
Q Serve(g_s), s	0.0	0.0	0.0	0.2	0.0	0.0	0.4	4.3	0.8	0.9	4.5	0.6
Cycle Q Clear(g_c), s	1.4	0.0	0.0	1.6	0.0	0.0	0.4	4.3	0.8	0.9	4.5	0.6
Prop In Lane	0.43		0.15	0.21		0.50	1.00		1.00	1.00		1.00
Lane Grp Cap(c), veh/h	387	0	0	360	0	0	48	1126	502	104	1239	552
V/C Ratio(X)	0.23	0.00	0.00	0.27	0.00	0.00	0.44	0.54	0.11	0.50	0.53	0.08
Avail Cap(c_a), veh/h	1105	0	0	1097	0	0	293	2107	940	293	2107	940
HCM Platoon Ratio	1.00	1.00	1.00	1.00	1.00	1.00	1.00	1.00	1.00	1.00	1.00	1.00
Upstream Filter(l)	1.00	0.00	0.00	1.00	0.00	0.00	1.00	1.00	1.00	1.00	1.00	1.00
Uniform Delay (d), s/veh	12.1	0.0	0.0	12.2	0.0	0.0	14.6	8.5	7.4	13.9	7.9	6.6
Incr Delay (d2), s/veh	0.3	0.0	0.0	0.4	0.0	0.0	6.3	0.4	0.1	3.7	0.4	0.1
Initial Q Delay(d3),s/veh	0.0	0.0	0.0	0.0	0.0	0.0	0.0	0.0	0.0	0.0	0.0	0.0
%ile BackOfQ(50%),veh/ln	0.4	0.0	0.0	0.5	0.0	0.0	0.2	1.1	0.2	0.4	1.1	0.1
Unsig. Movement Delay, s/veh												
LnGrp Delay(d),s/veh	12.4	0.0	0.0	12.6	0.0	0.0	20.8	8.9	7.4	17.5	8.3	6.7
LnGrp LOS	B	A	A	B	A	A	C	A	A	B	A	A
Approach Vol, veh/h		89			98			684			752	
Approach Delay, s/veh		12.4			12.6			9.2			8.8	
Approach LOS		B			B			A			A	
Timer - Assigned Phs	1	2		4	5	6		8				
Phs Duration (G+Y+Rc), s	6.8	14.6		9.0	5.8	15.6		9.0				
Change Period (Y+Rc), s	5.0	5.0		5.0	5.0	5.0		5.0				
Max Green Setting (Gmax), s	5.0	18.0		18.0	5.0	18.0		18.0				
Max Q Clear Time (g_c+I1), s	2.9	6.3		3.4	2.4	6.5		3.6				
Green Ext Time (p_c), s	0.0	3.4		0.3	0.0	3.6		0.4				
Intersection Summary												
HCM 6th Ctrl Delay				9.4								
HCM 6th LOS				A								

Intersection												
Int Delay, s/veh	0.4											
Movement	EBL	EBT	EBR	WBL	WBT	WBR	NBL	NBT	NBR	SBL	SBT	SBR
Lane Configurations		↕			↕		↕	↕		↕	↕	
Traffic Vol, veh/h	20	3	2	1	2	5	0	614	1	1	596	8
Future Vol, veh/h	20	3	2	1	2	5	0	614	1	1	596	8
Conflicting Peds, #/hr	0	0	0	0	0	0	0	0	0	0	0	0
Sign Control	Stop	Stop	Stop	Stop	Stop	Stop	Free	Free	Free	Free	Free	Free
RT Channelized	-	-	None	-	-	None	-	-	None	-	-	None
Storage Length	-	-	-	-	-	-	50	-	-	50	-	-
Veh in Median Storage, #	-	1	-	-	1	-	-	0	-	-	0	-
Grade, %	-	0	-	-	0	-	-	0	-	-	0	-
Peak Hour Factor	94	94	94	94	94	94	94	94	94	94	94	94
Heavy Vehicles, %	2	2	2	2	2	2	2	2	2	2	2	2
Mvmt Flow	21	3	2	1	2	5	0	653	1	1	634	9

Major/Minor	Minor2		Minor1		Major1			Major2				
Conflicting Flow All	969	1295	322	975	1299	327	643	0	0	654	0	0
Stage 1	641	641	-	654	654	-	-	-	-	-	-	-
Stage 2	328	654	-	321	645	-	-	-	-	-	-	-
Critical Hdwy	7.54	6.54	6.94	7.54	6.54	6.94	4.14	-	-	4.14	-	-
Critical Hdwy Stg 1	6.54	5.54	-	6.54	5.54	-	-	-	-	-	-	-
Critical Hdwy Stg 2	6.54	5.54	-	6.54	5.54	-	-	-	-	-	-	-
Follow-up Hdwy	3.52	4.02	3.32	3.52	4.02	3.32	2.22	-	-	2.22	-	-
Pot Cap-1 Maneuver	208	161	674	206	160	669	938	-	-	929	-	-
Stage 1	430	468	-	422	461	-	-	-	-	-	-	-
Stage 2	659	461	-	665	466	-	-	-	-	-	-	-
Platoon blocked, %								-	-	-	-	-
Mov Cap-1 Maneuver	205	161	674	204	160	669	938	-	-	929	-	-
Mov Cap-2 Maneuver	324	285	-	321	285	-	-	-	-	-	-	-
Stage 1	430	468	-	422	461	-	-	-	-	-	-	-
Stage 2	651	461	-	658	466	-	-	-	-	-	-	-

Approach	EB		WB		NB		SB	
HCM Control Delay, s	16.8		13.1		0		0	
HCM LOS	C		B					

Minor Lane/Major Mvmt	NBL	NBT	NBR	EBLn1	WBLn1	SBL	SBT	SBR
Capacity (veh/h)	938	-	-	332	454	929	-	-
HCM Lane V/C Ratio	-	-	-	0.08	0.019	0.001	-	-
HCM Control Delay (s)	0	-	-	16.8	13.1	8.9	-	-
HCM Lane LOS	A	-	-	C	B	A	-	-
HCM 95th %tile Q(veh)	0	-	-	0.3	0.1	0	-	-

Heritage at Dalia Ranch
3: Imperial Ave & Ralph Rd

Opening Year 2026 + P1-3 Proj
Timing Plan: AM PEAK

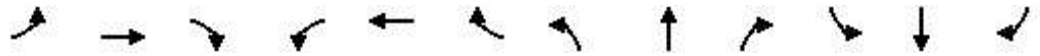

Movement	EBL	EBT	EBR	WBL	WBT	WBR	NBL	NBT	NBR	SBL	SBT	SBR
Lane Configurations	↖	↗		↖	↗		↖	↕		↖	↕	↖
Traffic Volume (veh/h)	60	11	106	61	17	24	134	532	43	20	547	31
Future Volume (veh/h)	60	11	106	61	17	24	134	532	43	20	547	31
Initial Q (Qb), veh	0	0	0	0	0	0	0	0	0	0	0	0
Ped-Bike Adj(A_pbT)	1.00		1.00	1.00		1.00	1.00		1.00	1.00		1.00
Parking Bus, Adj	1.00	1.00	1.00	1.00	1.00	1.00	1.00	1.00	1.00	1.00	1.00	1.00
Work Zone On Approach		No			No			No			No	
Adj Sat Flow, veh/h/ln	1870	1870	1870	1870	1870	1870	1870	1870	1870	1870	1870	1870
Adj Flow Rate, veh/h	65	12	115	67	18	26	146	585	47	22	601	34
Peak Hour Factor	0.92	0.92	0.92	0.91	0.92	0.91	0.92	0.91	0.91	0.91	0.91	0.92
Percent Heavy Veh, %	2	2	2	2	2	2	2	2	2	2	2	2
Cap, veh/h	183	19	178	170	80	115	186	1102	88	47	899	401
Arrive On Green	0.10	0.12	0.12	0.10	0.12	0.12	0.10	0.33	0.33	0.03	0.25	0.25
Sat Flow, veh/h	1781	152	1456	1781	692	999	1781	3332	267	1781	3554	1585
Grp Volume(v), veh/h	65	0	127	67	0	44	146	312	320	22	601	34
Grp Sat Flow(s),veh/h/ln	1781	0	1608	1781	0	1691	1781	1777	1822	1781	1777	1585
Q Serve(g_s), s	1.6	0.0	3.5	1.7	0.0	1.1	3.8	6.7	6.7	0.6	7.2	0.8
Cycle Q Clear(g_c), s	1.6	0.0	3.5	1.7	0.0	1.1	3.8	6.7	6.7	0.6	7.2	0.8
Prop In Lane	1.00		0.91	1.00		0.59	1.00		0.15	1.00		1.00
Lane Grp Cap(c), veh/h	183	0	197	170	0	195	186	588	603	47	899	401
V/C Ratio(X)	0.36	0.00	0.65	0.39	0.00	0.23	0.78	0.53	0.53	0.47	0.67	0.08
Avail Cap(c_a), veh/h	681	0	615	681	0	646	227	717	735	189	1359	606
HCM Platoon Ratio	1.00	1.00	1.00	1.00	1.00	1.00	1.00	1.00	1.00	1.00	1.00	1.00
Upstream Filter(l)	1.00	0.00	1.00	1.00	0.00	1.00	1.00	1.00	1.00	1.00	1.00	1.00
Uniform Delay (d), s/veh	19.7	0.0	19.7	20.0	0.0	18.9	20.6	12.8	12.8	22.6	15.8	13.4
Incr Delay (d2), s/veh	1.2	0.0	3.5	1.5	0.0	0.6	13.6	0.7	0.7	6.9	0.9	0.1
Initial Q Delay(d3),s/veh	0.0	0.0	0.0	0.0	0.0	0.0	0.0	0.0	0.0	0.0	0.0	0.0
%ile BackOfQ(50%),veh/ln	0.7	0.0	1.4	0.7	0.0	0.4	2.1	2.3	2.4	0.3	2.6	0.2
Unsig. Movement Delay, s/veh												
LnGrp Delay(d),s/veh	20.8	0.0	23.2	21.5	0.0	19.5	34.2	13.5	13.5	29.5	16.7	13.5
LnGrp LOS	C	A	C	C	A	B	C	B	B	C	B	B
Approach Vol, veh/h		192			111			778			657	
Approach Delay, s/veh		22.4			20.7			17.4			17.0	
Approach LOS		C			C			B			B	
Timer - Assigned Phs	1	2	3	4	5	6	7	8				
Phs Duration (G+Y+Rc), s	6.3	20.6	9.5	10.8	9.9	16.9	9.8	10.4				
Change Period (Y+Rc), s	5.0	5.0	5.0	5.0	5.0	5.0	5.0	5.0				
Max Green Setting (Gmax), s	5.0	19.0	18.0	18.0	6.0	18.0	18.0	18.0				
Max Q Clear Time (g_c+I1), s	2.6	8.7	3.7	5.5	5.8	9.2	3.6	3.1				
Green Ext Time (p_c), s	0.0	2.8	0.1	0.5	0.0	2.7	0.1	0.1				
Intersection Summary												
HCM 6th Ctrl Delay			18.0									
HCM 6th LOS			B									

Heritage at Dalia Ranch
4: Imperial Ave & Neckel Rd

Opening Year 2026 + P1-3 Proj
Timing Plan: AM PEAK



Movement	EBL	EBT	EBR	WBL	WBT	WBR	NBL	NBT	NBR	SBL	SBT	SBR
Lane Configurations		↕			↕		↕	↕		↕	↕	
Traffic Volume (veh/h)	35	45	65	228	66	102	27	578	95	35	671	32
Future Volume (veh/h)	35	45	65	228	66	102	27	578	95	35	671	32
Initial Q (Qb), veh	0	0	0	0	0	0	0	0	0	0	0	0
Ped-Bike Adj(A_pbT)	1.00		1.00	1.00		1.00	1.00		1.00	1.00		1.00
Parking Bus, Adj	1.00	1.00	1.00	1.00	1.00	1.00	1.00	1.00	1.00	1.00	1.00	1.00
Work Zone On Approach		No			No			No			No	
Adj Sat Flow, veh/h/ln	1870	1870	1870	1870	1870	1870	1870	1870	1870	1870	1870	1870
Adj Flow Rate, veh/h	38	49	71	251	73	112	30	635	104	38	737	35
Peak Hour Factor	0.91	0.91	0.91	0.91	0.91	0.91	0.91	0.91	0.91	0.91	0.91	0.91
Percent Heavy Veh, %	2	2	2	2	2	2	2	2	2	2	2	2
Cap, veh/h	50	64	93	275	80	123	57	780	128	68	902	43
Arrive On Green	0.12	0.12	0.12	0.28	0.28	0.28	0.03	0.26	0.26	0.04	0.26	0.26
Sat Flow, veh/h	412	531	769	1002	291	447	1781	3057	500	1781	3454	164
Grp Volume(v), veh/h	158	0	0	436	0	0	30	369	370	38	379	393
Grp Sat Flow(s),veh/h/ln	1711	0	0	1740	0	0	1781	1777	1780	1781	1777	1841
Q Serve(g_s), s	5.8	0.0	0.0	15.6	0.0	0.0	1.1	12.6	12.6	1.4	12.9	12.9
Cycle Q Clear(g_c), s	5.8	0.0	0.0	15.6	0.0	0.0	1.1	12.6	12.6	1.4	12.9	12.9
Prop In Lane	0.24		0.45	0.58		0.26	1.00		0.28	1.00		0.09
Lane Grp Cap(c), veh/h	208	0	0	479	0	0	57	453	454	68	464	481
V/C Ratio(X)	0.76	0.00	0.00	0.91	0.00	0.00	0.52	0.81	0.82	0.56	0.82	0.82
Avail Cap(c_a), veh/h	478	0	0	486	0	0	138	523	525	138	523	542
HCM Platoon Ratio	1.00	1.00	1.00	1.00	1.00	1.00	1.00	1.00	1.00	1.00	1.00	1.00
Upstream Filter(I)	1.00	0.00	0.00	1.00	0.00	0.00	1.00	1.00	1.00	1.00	1.00	1.00
Uniform Delay (d), s/veh	27.4	0.0	0.0	22.6	0.0	0.0	30.7	22.6	22.6	30.5	22.4	22.4
Incr Delay (d2), s/veh	5.6	0.0	0.0	21.2	0.0	0.0	7.2	8.4	8.6	6.9	8.9	8.6
Initial Q Delay(d3),s/veh	0.0	0.0	0.0	0.0	0.0	0.0	0.0	0.0	0.0	0.0	0.0	0.0
%ile BackOfQ(50%),veh/ln	2.6	0.0	0.0	8.7	0.0	0.0	0.6	5.9	6.0	0.7	6.1	6.3
Unsig. Movement Delay, s/veh												
LnGrp Delay(d),s/veh	33.1	0.0	0.0	43.8	0.0	0.0	37.9	31.0	31.1	37.4	31.2	31.0
LnGrp LOS	C	A	A	D	A	A	D	C	C	D	C	C
Approach Vol, veh/h		158			436			769			810	
Approach Delay, s/veh		33.1			43.8			31.3			31.4	
Approach LOS		C			D			C			C	
Timer - Assigned Phs	1	2		4	5	6		8				
Phs Duration (G+Y+Rc), s	7.5	21.5		12.8	7.1	21.8		22.7				
Change Period (Y+Rc), s	5.0	5.0		5.0	5.0	5.0		5.0				
Max Green Setting (Gmax), s	5.0	19.0		18.0	5.0	19.0		18.0				
Max Q Clear Time (g_c+1), s	13.4	14.6		7.8	3.1	14.9		17.6				
Green Ext Time (p_c), s	0.0	1.8		0.6	0.0	1.8		0.1				
Intersection Summary												
HCM 6th Ctrl Delay				34.0								
HCM 6th LOS				C								

Intersection												
Int Delay, s/veh	9.1											
Movement	EBL	EBT	EBR	WBL	WBT	WBR	NBL	NBT	NBR	SBL	SBT	SBR
Lane Configurations		↕			↕			↕			↕	
Traffic Vol, veh/h	4	43	24	69	46	67	8	28	47	77	25	1
Future Vol, veh/h	4	43	24	69	46	67	8	28	47	77	25	1
Conflicting Peds, #/hr	0	0	0	0	0	0	0	0	0	0	0	0
Sign Control	Stop	Stop	Stop	Stop	Stop	Stop	Free	Free	Free	Free	Free	Free
RT Channelized	-	-	None	-	-	None	-	-	None	-	-	None
Storage Length	-	-	-	-	-	-	-	-	-	-	-	-
Veh in Median Storage, #	-	0	-	-	0	-	-	0	-	-	0	-
Grade, %	-	0	-	-	0	-	-	0	-	-	0	-
Peak Hour Factor	79	79	79	79	79	79	79	79	79	79	79	79
Heavy Vehicles, %	2	2	2	2	2	2	2	2	2	2	2	2
Mvmt Flow	5	54	30	87	58	85	10	35	59	97	32	1

Major/Minor	Minor2		Minor1		Major1			Major2				
Conflicting Flow All	383	341	33	354	312	65	33	0	0	94	0	0
Stage 1	227	227	-	85	85	-	-	-	-	-	-	-
Stage 2	156	114	-	269	227	-	-	-	-	-	-	-
Critical Hdwy	7.12	6.52	6.22	7.12	6.52	6.22	4.12	-	-	4.12	-	-
Critical Hdwy Stg 1	6.12	5.52	-	6.12	5.52	-	-	-	-	-	-	-
Critical Hdwy Stg 2	6.12	5.52	-	6.12	5.52	-	-	-	-	-	-	-
Follow-up Hdwy	3.518	4.018	3.318	3.518	4.018	3.318	2.218	-	-	2.218	-	-
Pot Cap-1 Maneuver	575	581	1041	601	603	999	1579	-	-	1500	-	-
Stage 1	776	716	-	923	824	-	-	-	-	-	-	-
Stage 2	846	801	-	737	716	-	-	-	-	-	-	-
Platoon blocked, %								-	-	-	-	-
Mov Cap-1 Maneuver	458	539	1041	509	559	999	1579	-	-	1500	-	-
Mov Cap-2 Maneuver	458	539	-	509	559	-	-	-	-	-	-	-
Stage 1	771	669	-	917	818	-	-	-	-	-	-	-
Stage 2	714	795	-	614	669	-	-	-	-	-	-	-

Approach	EB		WB		NB		SB	
HCM Control Delay, s	11.6		13.8		0.7		5.7	
HCM LOS	B		B					

Minor Lane/Major Mvmt	NBL	NBT	NBR	EBLn1	WBLn1	SBL	SBT	SBR
Capacity (veh/h)	1579	-	-	636	639	1500	-	-
HCM Lane V/C Ratio	0.006	-	-	0.141	0.361	0.065	-	-
HCM Control Delay (s)	7.3	0	-	11.6	13.8	7.6	0	-
HCM Lane LOS	A	A	-	B	B	A	A	-
HCM 95th %tile Q(veh)	0	-	-	0.5	1.6	0.2	-	-

Heritage at Dalia Ranch
6: Imperial Ave & Worthington Rd/Barioni Blvd

Opening Year 2026 + P1-3 Proj
Timing Plan: AM PEAK

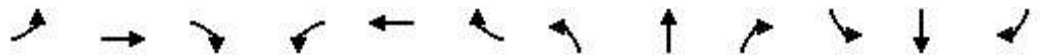

Movement	EBL	EBT	EBR	WBL	WBT	WBR	NBL	NBT	NBR	SBL	SBT	SBR
Lane Configurations		↕	↗		↕	↗	↗	↕↗		↗	↕↗	
Traffic Volume (veh/h)	78	142	221	57	137	104	96	618	53	72	883	71
Future Volume (veh/h)	78	142	221	57	137	104	96	618	53	72	883	71
Initial Q (Qb), veh	0	0	0	0	0	0	0	0	0	0	0	0
Ped-Bike Adj(A_pbT)	1.00		1.00	1.00		1.00	1.00		1.00	1.00		1.00
Parking Bus, Adj	1.00	1.00	1.00	1.00	1.00	1.00	1.00	1.00	1.00	1.00	1.00	1.00
Work Zone On Approach		No			No			No			No	
Adj Sat Flow, veh/h/ln	1870	1870	1870	1870	1870	1870	1870	1870	1870	1870	1870	1870
Adj Flow Rate, veh/h	88	160	248	64	154	117	108	694	60	81	992	80
Peak Hour Factor	0.89	0.89	0.89	0.89	0.89	0.89	0.89	0.89	0.89	0.89	0.89	0.89
Percent Heavy Veh, %	2	2	2	2	2	2	2	2	2	2	2	2
Cap, veh/h	128	233	311	85	205	249	131	974	84	104	930	75
Arrive On Green	0.20	0.20	0.20	0.16	0.16	0.16	0.07	0.29	0.29	0.06	0.28	0.28
Sat Flow, veh/h	652	1186	1585	541	1302	1585	1781	3310	286	1781	3330	269
Grp Volume(v), veh/h	248	0	248	218	0	117	108	372	382	81	529	543
Grp Sat Flow(s),veh/h/ln	1838	0	1585	1843	0	1585	1781	1777	1819	1781	1777	1822
Q Serve(g_s), s	8.5	0.0	10.1	7.7	0.0	4.6	4.1	12.7	12.8	3.1	19.0	19.0
Cycle Q Clear(g_c), s	8.5	0.0	10.1	7.7	0.0	4.6	4.1	12.7	12.8	3.1	19.0	19.0
Prop In Lane	0.35		1.00	0.29		1.00	1.00		0.16	1.00		0.15
Lane Grp Cap(c), veh/h	361	0	311	290	0	249	131	523	535	104	496	509
V/C Ratio(X)	0.69	0.00	0.80	0.75	0.00	0.47	0.83	0.71	0.71	0.78	1.07	1.07
Avail Cap(c_a), veh/h	486	0	419	487	0	419	131	523	535	131	496	509
HCM Platoon Ratio	1.00	1.00	1.00	1.00	1.00	1.00	1.00	1.00	1.00	1.00	1.00	1.00
Upstream Filter(l)	1.00	0.00	1.00	1.00	0.00	1.00	1.00	1.00	1.00	1.00	1.00	1.00
Uniform Delay (d), s/veh	25.4	0.0	26.1	27.4	0.0	26.1	31.1	21.4	21.4	31.6	24.5	24.5
Incr Delay (d2), s/veh	2.5	0.0	7.5	3.9	0.0	1.4	33.2	4.5	4.4	20.7	59.4	59.0
Initial Q Delay(d3),s/veh	0.0	0.0	0.0	0.0	0.0	0.0	0.0	0.0	0.0	0.0	0.0	0.0
%ile BackOfQ(50%),veh/ln	3.8	0.0	4.3	3.5	0.0	1.7	2.9	5.6	5.7	1.9	15.6	15.9
Unsig. Movement Delay, s/veh												
LnGrp Delay(d),s/veh	27.9	0.0	33.6	31.3	0.0	27.5	64.3	25.9	25.9	52.3	84.0	83.6
LnGrp LOS	C	A	C	C	A	C	E	C	C	D	F	F
Approach Vol, veh/h		496			335			862			1153	
Approach Delay, s/veh		30.8			30.0			30.7			81.6	
Approach LOS		C			C			C			F	
Timer - Assigned Phs	1	2		4	5	6		8				
Phs Duration (G+Y+Rc), s	9.0	25.0		18.4	10.0	24.0		15.7				
Change Period (Y+Rc), s	5.0	5.0		5.0	5.0	5.0		5.0				
Max Green Setting (Gmax), s	5.0	19.0		18.0	5.0	19.0		18.0				
Max Q Clear Time (g_c+I1), s	5.1	14.8		12.1	6.1	21.0		9.7				
Green Ext Time (p_c), s	0.0	1.8		1.2	0.0	0.0		1.0				
Intersection Summary												
HCM 6th Ctrl Delay				51.2								
HCM 6th LOS				D								

Intersection

Intersection Delay, s/veh 27.7
Intersection LOS D

Movement	EBL	EBT	EBR	WBL	WBT	WBR	NBL	NBT	NBR	SBL	SBT	SBR
Lane Configurations		↔	↔		↔	↔		↔			↔	
Traffic Vol, veh/h	87	411	124	12	327	80	0	0	1	110	32	97
Future Vol, veh/h	87	411	124	12	327	80	0	0	1	110	32	97
Peak Hour Factor	0.92	0.92	0.92	0.92	0.92	0.92	0.92	0.92	0.92	0.92	0.92	0.92
Heavy Vehicles, %	2	2	2	2	2	2	2	2	2	2	2	2
Mvmt Flow	95	447	135	13	355	87	0	0	1	120	35	105
Number of Lanes	0	1	1	0	1	1	0	1	0	0	1	0

Approach	EB	WB	NB	SB
Opposing Approach	WB	EB	SB	NB
Opposing Lanes	2	2	1	1
Conflicting Approach Left SB		NB	EB	WB
Conflicting Lanes Left	1	1	2	2
Conflicting Approach Right NB		SB	WB	EB
Conflicting Lanes Right	1	1	2	2
HCM Control Delay	38.8	18.3	10.1	15.1
HCM LOS	E	C	B	C

Lane	NBLn1	EBLn1	EBLn2	WBLn1	WBLn2	SBLn1
Vol Left, %	0%	17%	0%	4%	0%	46%
Vol Thru, %	0%	83%	0%	96%	0%	13%
Vol Right, %	100%	0%	100%	0%	100%	41%
Sign Control	Stop	Stop	Stop	Stop	Stop	Stop
Traffic Vol by Lane	1	498	124	339	80	239
LT Vol	0	87	0	12	0	110
Through Vol	0	411	0	327	0	32
RT Vol	1	0	124	0	80	97
Lane Flow Rate	1	541	135	368	87	260
Geometry Grp	2	7	7	7	7	2
Degree of Util (X)	0.002	0.927	0.201	0.652	0.136	0.465
Departure Headway (Hd)	7.078	6.168	5.368	6.371	5.64	6.449
Convergence, Y/N	Yes	Yes	Yes	Yes	Yes	Yes
Cap	509	585	666	564	632	556
Service Time	5.078	3.929	3.128	4.142	3.41	4.518
HCM Lane V/C Ratio	0.002	0.925	0.203	0.652	0.138	0.468
HCM Control Delay	10.1	46.1	9.5	20.4	9.3	15.1
HCM Lane LOS	B	E	A	C	A	C
HCM 95th-tile Q	0	11.8	0.7	4.7	0.5	2.4

Heritage at Dalia Ranch
8: Imperial Ave & Aten Rd

Opening Year 2026 + P1-3 Proj
Timing Plan: AM PEAK



Movement	EBL	EBT	EBR	WBL	WBT	WBR	NBL	NBT	NBR	SBL	SBT	SBR
Lane Configurations												
Traffic Volume (veh/h)	223	352	65	136	312	171	63	437	70	179	852	435
Future Volume (veh/h)	223	352	65	136	312	171	63	437	70	179	852	435
Initial Q (Qb), veh	0	0	0	0	0	0	0	0	0	0	0	0
Ped-Bike Adj(A_pbT)	1.00		1.00	1.00		1.00	1.00		1.00	1.00		1.00
Parking Bus, Adj	1.00	1.00	1.00	1.00	1.00	1.00	1.00	1.00	1.00	1.00	1.00	1.00
Work Zone On Approach		No		No		No		No		No		No
Adj Sat Flow, veh/h/ln	1870	1870	1870	1870	1870	1870	1870	1870	1870	1870	1870	1870
Adj Flow Rate, veh/h	259	409	76	158	363	199	73	508	81	208	991	506
Peak Hour Factor	0.86	0.86	0.86	0.86	0.86	0.86	0.86	0.86	0.86	0.86	0.86	0.86
Percent Heavy Veh, %	2	2	2	2	2	2	2	2	2	2	2	2
Cap, veh/h	298	774	143	197	449	242	94	815	363	247	1121	500
Arrive On Green	0.17	0.26	0.26	0.11	0.20	0.20	0.05	0.23	0.23	0.14	0.32	0.32
Sat Flow, veh/h	1781	2996	552	1781	2229	1202	1781	3554	1585	1781	3554	1585
Grp Volume(v), veh/h	259	241	244	158	288	274	73	508	81	208	991	506
Grp Sat Flow(s),veh/h/ln	1781	1777	1771	1781	1777	1654	1781	1777	1585	1781	1777	1585
Q Serve(g_s), s	10.8	8.9	9.0	6.6	11.8	12.1	3.1	9.8	3.2	8.7	20.1	24.0
Cycle Q Clear(g_c), s	10.8	8.9	9.0	6.6	11.8	12.1	3.1	9.8	3.2	8.7	20.1	24.0
Prop In Lane	1.00		0.31	1.00		0.73	1.00		1.00	1.00		1.00
Lane Grp Cap(c), veh/h	298	459	457	197	358	333	94	815	363	247	1121	500
V/C Ratio(X)	0.87	0.53	0.53	0.80	0.80	0.82	0.78	0.62	0.22	0.84	0.88	1.01
Avail Cap(c_a), veh/h	304	459	457	304	420	391	117	841	375	258	1121	500
HCM Platoon Ratio	1.00	1.00	1.00	1.00	1.00	1.00	1.00	1.00	1.00	1.00	1.00	1.00
Upstream Filter(l)	1.00	1.00	1.00	1.00	1.00	1.00	1.00	1.00	1.00	1.00	1.00	1.00
Uniform Delay (d), s/veh	30.8	24.2	24.3	33.0	28.9	29.1	35.6	26.4	23.8	31.9	24.7	26.0
Incr Delay (d2), s/veh	22.2	1.1	1.2	8.3	9.5	11.5	22.8	1.4	0.3	20.9	8.6	43.2
Initial Q Delay(d3),s/veh	0.0	0.0	0.0	0.0	0.0	0.0	0.0	0.0	0.0	0.0	0.0	0.0
%ile BackOfQ(50%),veh/ln	6.3	3.7	3.8	3.2	5.8	5.7	1.9	4.1	1.2	5.0	9.3	14.5
Unsig. Movement Delay, s/veh												
LnGrp Delay(d),s/veh	53.0	25.3	25.5	41.3	38.4	40.5	58.4	27.7	24.1	52.9	33.3	69.3
LnGrp LOS	D	C	C	D	D	D	E	C	C	D	C	F
Approach Vol, veh/h		744			720			662			1705	
Approach Delay, s/veh		35.0			39.8			30.7			46.4	
Approach LOS		D			D			C			D	
Timer - Assigned Phs	1	2	3	4	5	6	7	8				
Phs Duration (G+Y+Rc), s	5.6	22.4	13.4	24.7	9.0	29.0	17.7	20.3				
Change Period (Y+Rc), s	5.0	5.0	5.0	5.0	5.0	5.0	5.0	5.0				
Max Green Setting (Gmax), s	18.0	18.0	13.0	18.0	5.0	24.0	13.0	18.0				
Max Q Clear Time (g_c+110), s	11.8	8.6	8.6	11.0	5.1	26.0	12.8	14.1				
Green Ext Time (p_c), s	0.0	1.9	0.2	1.7	0.0	0.0	0.0	1.3				
Intersection Summary												
HCM 6th Ctrl Delay											40.2	
HCM 6th LOS											D	

Intersection						
Int Delay, s/veh	2.2					
Movement	EBL	EBT	WBT	WBR	SBL	SBR
Lane Configurations	↖	↑	↗		↖	↗
Traffic Vol, veh/h	3	93	107	18	52	7
Future Vol, veh/h	3	93	107	18	52	7
Conflicting Peds, #/hr	0	0	0	0	0	0
Sign Control	Free	Free	Free	Free	Stop	Stop
RT Channelized	-	None	-	None	-	None
Storage Length	50	-	-	-	0	0
Veh in Median Storage, #	-	0	0	-	0	-
Grade, %	-	0	0	-	0	-
Peak Hour Factor	92	92	92	92	92	92
Heavy Vehicles, %	2	2	2	2	2	2
Mvmt Flow	3	101	116	20	57	8

Major/Minor	Major1	Major2	Minor2		
Conflicting Flow All	136	0	-	0	233
Stage 1	-	-	-	-	126
Stage 2	-	-	-	-	107
Critical Hdwy	4.12	-	-	-	6.42
Critical Hdwy Stg 1	-	-	-	-	5.42
Critical Hdwy Stg 2	-	-	-	-	5.42
Follow-up Hdwy	2.218	-	-	-	3.518
Pot Cap-1 Maneuver	1448	-	-	-	755
Stage 1	-	-	-	-	900
Stage 2	-	-	-	-	917
Platoon blocked, %		-	-	-	
Mov Cap-1 Maneuver	1448	-	-	-	753
Mov Cap-2 Maneuver	-	-	-	-	753
Stage 1	-	-	-	-	898
Stage 2	-	-	-	-	917

Approach	EB	WB	SB
HCM Control Delay, s	0.2	0	10
HCM LOS			B

Minor Lane/Major Mvmt	EBL	EBT	WBT	WBR	SBLn1	SBLn2
Capacity (veh/h)	1448	-	-	-	753	924
HCM Lane V/C Ratio	0.002	-	-	-	0.075	0.008
HCM Control Delay (s)	7.5	-	-	-	10.2	8.9
HCM Lane LOS	A	-	-	-	B	A
HCM 95th %tile Q(veh)	0	-	-	-	0.2	0

Intersection						
Int Delay, s/veh	0.7					
Movement	WBL	WBR	NBT	NBR	SBL	SBT
Lane Configurations	↔	↔	↔		↔	↔
Traffic Vol, veh/h	7	0	43	3	0	32
Future Vol, veh/h	7	0	43	3	0	32
Conflicting Peds, #/hr	0	0	0	0	0	0
Sign Control	Stop	Stop	Free	Free	Free	Free
RT Channelized	-	None	-	None	-	None
Storage Length	0	0	-	-	50	-
Veh in Median Storage, #	0	-	0	-	-	0
Grade, %	0	-	0	-	-	0
Peak Hour Factor	92	92	92	92	92	92
Heavy Vehicles, %	2	2	2	2	2	2
Mvmt Flow	8	0	47	3	0	35

Major/Minor	Minor1	Major1	Major2		
Conflicting Flow All	84	49	0	0	50
Stage 1	49	-	-	-	-
Stage 2	35	-	-	-	-
Critical Hdwy	6.42	6.22	-	-	4.12
Critical Hdwy Stg 1	5.42	-	-	-	-
Critical Hdwy Stg 2	5.42	-	-	-	-
Follow-up Hdwy	3.518	3.318	-	-	2.218
Pot Cap-1 Maneuver	918	1020	-	-	1557
Stage 1	973	-	-	-	-
Stage 2	987	-	-	-	-
Platoon blocked, %					
Mov Cap-1 Maneuver	918	1020	-	-	1557
Mov Cap-2 Maneuver	918	-	-	-	-
Stage 1	973	-	-	-	-
Stage 2	987	-	-	-	-

Approach	WB	NB	SB
HCM Control Delay, s	9	0	0
HCM LOS	A		

Minor Lane/Major Mvmt	NBT	NBRWBLn1WBLn2	SBL	SBT
Capacity (veh/h)	-	- 918	- 1557	-
HCM Lane V/C Ratio	-	- 0.008	-	-
HCM Control Delay (s)	-	- 9	0	0
HCM Lane LOS	-	- A	A	A
HCM 95th %tile Q(veh)	-	- 0	- 0	-

Intersection						
Int Delay, s/veh	5.4					
Movement	EBT	EBR	WBL	WBT	NBL	NBR
Lane Configurations	↔		↔	↑	↔	↔
Traffic Vol, veh/h	32	0	28	28	0	81
Future Vol, veh/h	32	0	28	28	0	81
Conflicting Peds, #/hr	0	0	0	0	0	0
Sign Control	Free	Free	Free	Free	Stop	Stop
RT Channelized	-	None	-	None	-	None
Storage Length	-	-	50	-	0	0
Veh in Median Storage, #	0	-	-	0	0	-
Grade, %	0	-	-	0	0	-
Peak Hour Factor	92	92	92	92	92	92
Heavy Vehicles, %	2	2	2	2	2	2
Mvmt Flow	35	0	30	30	0	88

Major/Minor	Major1	Major2	Minor1		
Conflicting Flow All	0	0	35	0	125 35
Stage 1	-	-	-	-	35 -
Stage 2	-	-	-	-	90 -
Critical Hdwy	-	-	4.12	-	6.42 6.22
Critical Hdwy Stg 1	-	-	-	-	5.42 -
Critical Hdwy Stg 2	-	-	-	-	5.42 -
Follow-up Hdwy	-	-	2.218	-	3.518 3.318
Pot Cap-1 Maneuver	-	-	1576	-	870 1038
Stage 1	-	-	-	-	987 -
Stage 2	-	-	-	-	934 -
Platoon blocked, %	-	-	-	-	-
Mov Cap-1 Maneuver	-	-	1576	-	853 1038
Mov Cap-2 Maneuver	-	-	-	-	853 -
Stage 1	-	-	-	-	987 -
Stage 2	-	-	-	-	916 -

Approach	EB	WB	NB
HCM Control Delay, s	0	3.7	8.8
HCM LOS			A

Minor Lane/Major Mvmt	NBLn1	NBLn2	EBT	EBR	WBL	WBT
Capacity (veh/h)	-	1038	-	-	1576	-
HCM Lane V/C Ratio	-	0.085	-	-	0.019	-
HCM Control Delay (s)	0	8.8	-	-	7.3	-
HCM Lane LOS	A	A	-	-	A	-
HCM 95th %tile Q(veh)	-	0.3	-	-	0.1	-

Intersection						
Int Delay, s/veh	2.4					
Movement	EBT	EBR	WBL	WBT	NBL	NBR
Lane Configurations	↔		↔	↑	↔	↔
Traffic Vol, veh/h	111	2	16	51	5	42
Future Vol, veh/h	111	2	16	51	5	42
Conflicting Peds, #/hr	0	0	0	0	0	0
Sign Control	Free	Free	Free	Free	Stop	Stop
RT Channelized	-	None	-	None	-	None
Storage Length	-	-	50	-	0	0
Veh in Median Storage, #	0	-	-	0	0	-
Grade, %	0	-	-	0	0	-
Peak Hour Factor	92	92	92	92	92	92
Heavy Vehicles, %	2	2	2	2	2	2
Mvmt Flow	121	2	17	55	5	46

Major/Minor	Major1	Major2	Minor1		
Conflicting Flow All	0	0	123	0	211
Stage 1	-	-	-	-	122
Stage 2	-	-	-	-	89
Critical Hdwy	-	-	4.12	-	6.42
Critical Hdwy Stg 1	-	-	-	-	5.42
Critical Hdwy Stg 2	-	-	-	-	5.42
Follow-up Hdwy	-	-	2.218	-	3.518
Pot Cap-1 Maneuver	-	-	1464	-	777
Stage 1	-	-	-	-	903
Stage 2	-	-	-	-	934
Platoon blocked, %	-	-	-	-	-
Mov Cap-1 Maneuver	-	-	1464	-	768
Mov Cap-2 Maneuver	-	-	-	-	768
Stage 1	-	-	-	-	903
Stage 2	-	-	-	-	923

Approach	EB	WB	NB
HCM Control Delay, s	0	1.8	9.2
HCM LOS			A

Minor Lane/Major Mvmt	NBLn1	NBLn2	EBT	EBR	WBL	WBT
Capacity (veh/h)	768	929	-	-	1464	-
HCM Lane V/C Ratio	0.007	0.049	-	-	0.012	-
HCM Control Delay (s)	9.7	9.1	-	-	7.5	-
HCM Lane LOS	A	A	-	-	A	-
HCM 95th %tile Q(veh)	0	0.2	-	-	0	-

Intersection						
Int Delay, s/veh	6					
Movement	EBT	EBR	WBL	WBT	NBL	NBR
Lane Configurations	↶		↷	↶	↷	↷
Traffic Vol, veh/h	123	30	242	44	23	116
Future Vol, veh/h	123	30	242	44	23	116
Conflicting Peds, #/hr	0	0	0	0	0	0
Sign Control	Free	Free	Free	Free	Stop	Stop
RT Channelized	-	None	-	None	-	None
Storage Length	-	-	100	-	0	0
Veh in Median Storage, #	0	-	-	0	0	-
Grade, %	0	-	-	0	0	-
Peak Hour Factor	92	92	92	92	92	92
Heavy Vehicles, %	2	2	2	2	2	2
Mvmt Flow	134	33	263	48	25	126

Major/Minor	Major1	Major2	Minor1		
Conflicting Flow All	0	0	167	0	725 151
Stage 1	-	-	-	-	151 -
Stage 2	-	-	-	-	574 -
Critical Hdwy	-	-	4.12	-	6.42 6.22
Critical Hdwy Stg 1	-	-	-	-	5.42 -
Critical Hdwy Stg 2	-	-	-	-	5.42 -
Follow-up Hdwy	-	-	2.218	-	3.518 3.318
Pot Cap-1 Maneuver	-	-	1411	-	392 895
Stage 1	-	-	-	-	877 -
Stage 2	-	-	-	-	563 -
Platoon blocked, %	-	-	-	-	-
Mov Cap-1 Maneuver	-	-	1411	-	319 895
Mov Cap-2 Maneuver	-	-	-	-	319 -
Stage 1	-	-	-	-	877 -
Stage 2	-	-	-	-	458 -

Approach	EB	WB	NB
HCM Control Delay, s	0	6.9	10.9
HCM LOS			B

Minor Lane/Major Mvmt	NBLn1	NBLn2	EBT	EBR	WBL	WBT
Capacity (veh/h)	319	895	-	-	1411	-
HCM Lane V/C Ratio	0.078	0.141	-	-	0.186	-
HCM Control Delay (s)	17.2	9.7	-	-	8.1	-
HCM Lane LOS	C	A	-	-	A	-
HCM 95th %tile Q(veh)	0.3	0.5	-	-	0.7	-

Intersection						
Int Delay, s/veh	0.7					
Movement	EBL	EBR	NBL	NBT	SBT	SBR
Lane Configurations		↗		↕↕	↕↕	↗
Traffic Vol, veh/h	0	92	0	760	713	30
Future Vol, veh/h	0	92	0	760	713	30
Conflicting Peds, #/hr	0	0	0	0	0	0
Sign Control	Stop	Stop	Free	Free	Free	Free
RT Channelized	-	None	-	None	-	None
Storage Length	-	0	-	-	-	100
Veh in Median Storage, #	0	-	-	0	0	-
Grade, %	0	-	-	0	0	-
Peak Hour Factor	92	92	92	92	92	92
Heavy Vehicles, %	2	2	2	2	2	2
Mvmt Flow	0	100	0	826	775	33

Major/Minor	Minor2	Major1	Major2		
Conflicting Flow All	-	388	-	0	-
Stage 1	-	-	-	-	-
Stage 2	-	-	-	-	-
Critical Hdwy	-	6.94	-	-	-
Critical Hdwy Stg 1	-	-	-	-	-
Critical Hdwy Stg 2	-	-	-	-	-
Follow-up Hdwy	-	3.32	-	-	-
Pot Cap-1 Maneuver	0	611	0	-	-
Stage 1	0	-	0	-	-
Stage 2	0	-	0	-	-
Platoon blocked, %				-	-
Mov Cap-1 Maneuver	-	611	-	-	-
Mov Cap-2 Maneuver	-	-	-	-	-
Stage 1	-	-	-	-	-
Stage 2	-	-	-	-	-

Approach	EB	NB	SB
HCM Control Delay, s	12	0	0
HCM LOS	B		

Minor Lane/Major Mvmt	NBT	EBLn1	SBT	SBR
Capacity (veh/h)	-	611	-	-
HCM Lane V/C Ratio	-	0.164	-	-
HCM Control Delay (s)	-	12	-	-
HCM Lane LOS	-	B	-	-
HCM 95th %tile Q(veh)	-	0.6	-	-

Heritage at Dalia Ranch
1: SR-86 & Keystone Rd

Opening Year 2026 + P1-3 Proj
Timing Plan: PM PEAK

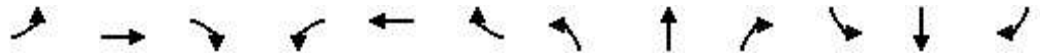

Movement	EBL	EBT	EBR	WBL	WBT	WBR	NBL	NBT	NBR	SBL	SBT	SBR
Lane Configurations		↕			↕		↗	↕	↗	↗	↕	↗
Traffic Volume (veh/h)	43	13	20	34	28	39	11	630	27	55	672	35
Future Volume (veh/h)	43	13	20	34	28	39	11	630	27	55	672	35
Initial Q (Qb), veh	0	0	0	0	0	0	0	0	0	0	0	0
Ped-Bike Adj(A_pbT)	1.00		1.00	1.00		1.00	1.00		1.00	1.00		1.00
Parking Bus, Adj	1.00	1.00	1.00	1.00	1.00	1.00	1.00	1.00	1.00	1.00	1.00	1.00
Work Zone On Approach		No			No			No			No	
Adj Sat Flow, veh/h/ln	1870	1870	1870	1870	1870	1870	1870	1870	1870	1870	1870	1870
Adj Flow Rate, veh/h	48	15	22	38	31	44	12	708	30	62	755	39
Peak Hour Factor	0.89	0.89	0.89	0.89	0.89	0.89	0.89	0.89	0.89	0.89	0.89	0.89
Percent Heavy Veh, %	2	2	2	2	2	2	2	2	2	2	2	2
Cap, veh/h	273	52	54	205	70	81	28	1245	556	117	1423	635
Arrive On Green	0.13	0.13	0.13	0.13	0.13	0.13	0.02	0.35	0.35	0.07	0.40	0.40
Sat Flow, veh/h	798	410	422	457	548	641	1781	3554	1585	1781	3554	1585
Grp Volume(v), veh/h	85	0	0	113	0	0	12	708	30	62	755	39
Grp Sat Flow(s),veh/h/ln	1630	0	0	1645	0	0	1781	1777	1585	1781	1777	1585
Q Serve(g_s), s	0.0	0.0	0.0	0.6	0.0	0.0	0.2	5.3	0.4	1.1	5.3	0.5
Cycle Q Clear(g_c), s	1.4	0.0	0.0	2.0	0.0	0.0	0.2	5.3	0.4	1.1	5.3	0.5
Prop In Lane	0.56		0.26	0.34		0.39	1.00		1.00	1.00		1.00
Lane Grp Cap(c), veh/h	379	0	0	356	0	0	28	1245	556	117	1423	635
V/C Ratio(X)	0.22	0.00	0.00	0.32	0.00	0.00	0.43	0.57	0.05	0.53	0.53	0.06
Avail Cap(c_a), veh/h	994	0	0	1015	0	0	271	2271	1013	325	2380	1061
HCM Platoon Ratio	1.00	1.00	1.00	1.00	1.00	1.00	1.00	1.00	1.00	1.00	1.00	1.00
Upstream Filter(l)	1.00	0.00	0.00	1.00	0.00	0.00	1.00	1.00	1.00	1.00	1.00	1.00
Uniform Delay (d), s/veh	13.1	0.0	0.0	13.4	0.0	0.0	16.0	8.7	7.1	14.9	7.5	6.1
Incr Delay (d2), s/veh	0.3	0.0	0.0	0.5	0.0	0.0	9.9	0.4	0.0	3.7	0.3	0.0
Initial Q Delay(d3),s/veh	0.0	0.0	0.0	0.0	0.0	0.0	0.0	0.0	0.0	0.0	0.0	0.0
%ile BackOfQ(50%),veh/ln	0.5	0.0	0.0	0.7	0.0	0.0	0.2	1.4	0.1	0.5	1.3	0.1
Unsig. Movement Delay, s/veh												
LnGrp Delay(d),s/veh	13.4	0.0	0.0	13.9	0.0	0.0	25.9	9.1	7.1	18.5	7.8	6.1
LnGrp LOS	B	A	A	B	A	A	C	A	A	B	A	A
Approach Vol, veh/h		85			113			750			856	
Approach Delay, s/veh		13.4			13.9			9.3			8.5	
Approach LOS		B			B			A			A	
Timer - Assigned Phs	1	2		4	5	6		8				
Phs Duration (G+Y+Rc), s	7.2	16.5		9.2	5.5	18.2		9.2				
Change Period (Y+Rc), s	5.0	5.0		5.0	5.0	5.0		5.0				
Max Green Setting (Gmax), s	6.0	21.0		18.0	5.0	22.0		18.0				
Max Q Clear Time (g_c+I1), s	3.1	7.3		3.4	2.2	7.3		4.0				
Green Ext Time (p_c), s	0.0	4.2		0.3	0.0	4.7		0.4				
Intersection Summary												
HCM 6th Ctrl Delay				9.4								
HCM 6th LOS				A								

Intersection												
Int Delay, s/veh	0.3											
Movement	EBL	EBT	EBR	WBL	WBT	WBR	NBL	NBT	NBR	SBL	SBT	SBR
Lane Configurations		↕			↕		↕	↕		↕	↕	
Traffic Vol, veh/h	6	4	0	8	0	5	1	669	8	6	709	18
Future Vol, veh/h	6	4	0	8	0	5	1	669	8	6	709	18
Conflicting Peds, #/hr	0	0	0	0	0	0	0	0	0	0	0	0
Sign Control	Stop	Stop	Stop	Stop	Stop	Stop	Free	Free	Free	Free	Free	Free
RT Channelized	-	-	None	-	-	None	-	-	None	-	-	None
Storage Length	-	-	-	-	-	-	50	-	-	50	-	-
Veh in Median Storage, #	-	1	-	-	1	-	-	0	-	-	0	-
Grade, %	-	0	-	-	0	-	-	0	-	-	0	-
Peak Hour Factor	92	92	92	92	92	92	92	92	92	92	92	92
Heavy Vehicles, %	2	2	2	2	2	2	2	2	2	2	2	2
Mvmt Flow	7	4	0	9	0	5	1	727	9	7	771	20

Major/Minor	Minor2		Minor1		Major1		Major2					
Conflicting Flow All	1161	1533	396	1136	1539	368	791	0	0	736	0	0
Stage 1	795	795	-	734	734	-	-	-	-	-	-	-
Stage 2	366	738	-	402	805	-	-	-	-	-	-	-
Critical Hdwy	7.54	6.54	6.94	7.54	6.54	6.94	4.14	-	-	4.14	-	-
Critical Hdwy Stg 1	6.54	5.54	-	6.54	5.54	-	-	-	-	-	-	-
Critical Hdwy Stg 2	6.54	5.54	-	6.54	5.54	-	-	-	-	-	-	-
Follow-up Hdwy	3.52	4.02	3.32	3.52	4.02	3.32	2.22	-	-	2.22	-	-
Pot Cap-1 Maneuver	150	115	603	157	115	629	825	-	-	865	-	-
Stage 1	347	398	-	378	424	-	-	-	-	-	-	-
Stage 2	626	422	-	596	393	-	-	-	-	-	-	-
Platoon blocked, %								-	-	-	-	-
Mov Cap-1 Maneuver	148	114	603	154	114	629	825	-	-	865	-	-
Mov Cap-2 Maneuver	262	237	-	275	237	-	-	-	-	-	-	-
Stage 1	347	395	-	378	424	-	-	-	-	-	-	-
Stage 2	620	422	-	585	390	-	-	-	-	-	-	-

Approach	EB		WB		NB		SB	
HCM Control Delay, s	20		15.7		0		0.1	
HCM LOS	C		C					

Minor Lane/Major Mvmt	NBL	NBT	NBR	EBLn1	WBLn1	SBL	SBT	SBR
Capacity (veh/h)	825	-	-	251	351	865	-	-
HCM Lane V/C Ratio	0.001	-	-	0.043	0.04	0.008	-	-
HCM Control Delay (s)	9.4	-	-	20	15.7	9.2	-	-
HCM Lane LOS	A	-	-	C	C	A	-	-
HCM 95th %tile Q(veh)	0	-	-	0.1	0.1	0	-	-

Heritage at Dalia Ranch
3: Imperial Ave & Ralph Rd

Opening Year 2026 + P1-3 Proj
Timing Plan: PM PEAK



Movement	EBL	EBT	EBR	WBL	WBT	WBR	NBL	NBT	NBR	SBL	SBT	SBR
Lane Configurations												
Traffic Volume (veh/h)	66	22	90	20	18	11	192	604	31	31	613	59
Future Volume (veh/h)	66	22	90	20	18	11	192	604	31	31	613	59
Initial Q (Qb), veh	0	0	0	0	0	0	0	0	0	0	0	0
Ped-Bike Adj(A_pbT)	1.00		1.00	1.00		1.00	1.00		1.00	1.00		1.00
Parking Bus, Adj	1.00	1.00	1.00	1.00	1.00	1.00	1.00	1.00	1.00	1.00	1.00	1.00
Work Zone On Approach		No			No			No			No	
Adj Sat Flow, veh/h/ln	1870	1870	1870	1870	1870	1870	1870	1870	1870	1870	1870	1870
Adj Flow Rate, veh/h	72	24	98	22	20	12	209	664	34	34	674	64
Peak Hour Factor	0.92	0.92	0.92	0.91	0.92	0.91	0.92	0.91	0.91	0.91	0.91	0.92
Percent Heavy Veh, %	2	2	2	2	2	2	2	2	2	2	2	2
Cap, veh/h	172	37	152	149	113	68	218	1220	62	67	960	428
Arrive On Green	0.10	0.12	0.12	0.08	0.10	0.10	0.12	0.35	0.35	0.04	0.27	0.27
Sat Flow, veh/h	1781	321	1313	1781	1095	657	1781	3440	176	1781	3554	1585
Grp Volume(v), veh/h	72	0	122	22	0	32	209	343	355	34	674	64
Grp Sat Flow(s),veh/h/ln	1781	0	1634	1781	0	1752	1781	1777	1839	1781	1777	1585
Q Serve(g_s), s	1.9	0.0	3.5	0.6	0.0	0.8	5.7	7.6	7.6	0.9	8.4	1.5
Cycle Q Clear(g_c), s	1.9	0.0	3.5	0.6	0.0	0.8	5.7	7.6	7.6	0.9	8.4	1.5
Prop In Lane	1.00		0.80	1.00		0.38	1.00		0.10	1.00		1.00
Lane Grp Cap(c), veh/h	172	0	190	149	0	180	218	630	652	67	960	428
V/C Ratio(X)	0.42	0.00	0.64	0.15	0.00	0.18	0.96	0.54	0.54	0.50	0.70	0.15
Avail Cap(c_a), veh/h	654	0	600	654	0	643	218	689	713	182	1305	582
HCM Platoon Ratio	1.00	1.00	1.00	1.00	1.00	1.00	1.00	1.00	1.00	1.00	1.00	1.00
Upstream Filter(l)	1.00	0.00	1.00	1.00	0.00	1.00	1.00	1.00	1.00	1.00	1.00	1.00
Uniform Delay (d), s/veh	20.8	0.0	20.7	20.8	0.0	20.1	21.4	12.7	12.7	23.1	16.1	13.6
Incr Delay (d2), s/veh	1.6	0.0	3.6	0.5	0.0	0.5	49.2	0.7	0.7	5.7	1.1	0.2
Initial Q Delay(d3),s/veh	0.0	0.0	0.0	0.0	0.0	0.0	0.0	0.0	0.0	0.0	0.0	0.0
%ile BackOfQ(50%),veh/ln	0.8	0.0	1.4	0.2	0.0	0.3	5.1	2.6	2.7	0.5	3.1	0.5
Unsig. Movement Delay, s/veh												
LnGrp Delay(d),s/veh	22.5	0.0	24.3	21.3	0.0	20.6	70.5	13.4	13.4	28.9	17.2	13.8
LnGrp LOS	C	A	C	C	A	C	E	B	B	C	B	B
Approach Vol, veh/h		194			54			907			772	
Approach Delay, s/veh		23.6			20.9			26.5			17.4	
Approach LOS		C			C			C			B	
Timer - Assigned Phs	1	2	3	4	5	6	7	8				
Phs Duration (G+Y+Rc), s	6.9	22.4	9.1	10.7	11.0	18.2	9.7	10.1				
Change Period (Y+Rc), s	5.0	5.0	5.0	5.0	5.0	5.0	5.0	5.0				
Max Green Setting (Gmax), s	5.0	19.0	18.0	18.0	6.0	18.0	18.0	18.0				
Max Q Clear Time (g_c+I1), s	2.9	9.6	2.6	5.5	7.7	10.4	3.9	2.8				
Green Ext Time (p_c), s	0.0	3.0	0.0	0.5	0.0	2.9	0.1	0.1				
Intersection Summary												
HCM 6th Ctrl Delay			22.4									
HCM 6th LOS			C									

Heritage at Dalia Ranch
4: Imperial Ave & Neckel Rd

Opening Year 2026 + P1-3 Proj
Timing Plan: PM PEAK



Movement	EBL	EBT	EBR	WBL	WBT	WBR	NBL	NBT	NBR	SBL	SBT	SBR
Lane Configurations		↕			↕		↕	↕		↕	↕	
Traffic Volume (veh/h)	13	27	38	139	20	84	71	754	178	82	672	29
Future Volume (veh/h)	13	27	38	139	20	84	71	754	178	82	672	29
Initial Q (Qb), veh	0	0	0	0	0	0	0	0	0	0	0	0
Ped-Bike Adj(A_pbT)	1.00		1.00	1.00		1.00	1.00		1.00	1.00		1.00
Parking Bus, Adj	1.00	1.00	1.00	1.00	1.00	1.00	1.00	1.00	1.00	1.00	1.00	1.00
Work Zone On Approach		No			No			No			No	
Adj Sat Flow, veh/h/ln	1870	1870	1870	1870	1870	1870	1870	1870	1870	1870	1870	1870
Adj Flow Rate, veh/h	14	29	41	151	22	91	77	820	193	89	730	32
Peak Hour Factor	0.92	0.92	0.92	0.92	0.92	0.92	0.92	0.92	0.92	0.92	0.92	0.92
Percent Heavy Veh, %	2	2	2	2	2	2	2	2	2	2	2	2
Cap, veh/h	18	38	54	191	28	115	110	924	217	118	1138	50
Arrive On Green	0.06	0.06	0.06	0.19	0.19	0.19	0.06	0.32	0.32	0.07	0.33	0.33
Sat Flow, veh/h	284	589	833	981	143	591	1781	2854	672	1781	3468	152
Grp Volume(v), veh/h	84	0	0	264	0	0	77	510	503	89	374	388
Grp Sat Flow(s),veh/h/ln1706	0	0	0	1715	0	0	1781	1777	1749	1781	1777	1843
Q Serve(g_s), s	2.8	0.0	0.0	8.4	0.0	0.0	2.4	15.5	15.6	2.8	10.2	10.2
Cycle Q Clear(g_c), s	2.8	0.0	0.0	8.4	0.0	0.0	2.4	15.5	15.6	2.8	10.2	10.2
Prop In Lane	0.17		0.49	0.57		0.34	1.00		0.38	1.00		0.08
Lane Grp Cap(c), veh/h	111	0	0	333	0	0	110	575	566	118	583	605
V/C Ratio(X)	0.76	0.00	0.00	0.79	0.00	0.00	0.70	0.89	0.89	0.75	0.64	0.64
Avail Cap(c_a), veh/h	538	0	0	541	0	0	156	592	583	156	592	614
HCM Platoon Ratio	1.00	1.00	1.00	1.00	1.00	1.00	1.00	1.00	1.00	1.00	1.00	1.00
Upstream Filter(l)	1.00	0.00	0.00	1.00	0.00	0.00	1.00	1.00	1.00	1.00	1.00	1.00
Uniform Delay (d), s/veh	26.2	0.0	0.0	21.9	0.0	0.0	26.2	18.3	18.3	26.2	16.3	16.3
Incr Delay (d2), s/veh	10.0	0.0	0.0	4.2	0.0	0.0	7.8	14.9	15.1	13.6	2.3	2.2
Initial Q Delay(d3),s/veh	0.0	0.0	0.0	0.0	0.0	0.0	0.0	0.0	0.0	0.0	0.0	0.0
%ile BackOfQ(50%),veh/ln1.4	0.0	0.0	0.0	3.5	0.0	0.0	1.2	8.0	7.9	1.6	4.0	4.2
Unsig. Movement Delay, s/veh												
LnGrp Delay(d),s/veh	36.3	0.0	0.0	26.1	0.0	0.0	34.0	33.2	33.4	39.8	18.6	18.5
LnGrp LOS	D	A	A	C	A	A	C	C	C	D	B	B
Approach Vol, veh/h		84		264			1090			851		
Approach Delay, s/veh		36.3		26.1			33.4			20.8		
Approach LOS		D		C			C			C		
Timer - Assigned Phs	1	2		4	5	6		8				
Phs Duration (G+Y+Rc), s8.8	23.5			8.7	8.5	23.7		16.1				
Change Period (Y+Rc), s 5.0	5.0			5.0	5.0	5.0		5.0				
Max Green Setting (Gmax), s 5.0	19.0			18.0	5.0	19.0		18.0				
Max Q Clear Time (g_c+14), s 14.8	17.6			4.8	4.4	12.2		10.4				
Green Ext Time (p_c), s	0.0	0.9		0.3	0.0	2.6		0.9				
Intersection Summary												
HCM 6th Ctrl Delay				28.0								
HCM 6th LOS				C								

Intersection												
Int Delay, s/veh	8.4											
Movement	EBL	EBT	EBR	WBL	WBT	WBR	NBL	NBT	NBR	SBL	SBT	SBR
Lane Configurations		↕			↕			↕			↕	
Traffic Vol, veh/h	2	40	9	29	46	105	5	36	19	94	34	8
Future Vol, veh/h	2	40	9	29	46	105	5	36	19	94	34	8
Conflicting Peds, #/hr	0	0	0	0	0	0	0	0	0	0	0	0
Sign Control	Stop	Stop	Stop	Stop	Stop	Stop	Free	Free	Free	Free	Free	Free
RT Channelized	-	-	None	-	-	None	-	-	None	-	-	None
Storage Length	-	-	-	-	-	-	-	-	-	-	-	-
Veh in Median Storage, #	-	0	-	-	0	-	-	0	-	-	0	-
Grade, %	-	0	-	-	0	-	-	0	-	-	0	-
Peak Hour Factor	79	79	79	79	79	79	79	79	79	79	79	79
Heavy Vehicles, %	2	2	2	2	2	2	2	2	2	2	2	2
Mvmt Flow	3	51	11	37	58	133	6	46	24	119	43	10

Major/Minor	Minor2		Minor1		Major1			Major2				
Conflicting Flow All	452	368	48	387	361	58	53	0	0	70	0	0
Stage 1	286	286	-	70	70	-	-	-	-	-	-	-
Stage 2	166	82	-	317	291	-	-	-	-	-	-	-
Critical Hdwy	7.12	6.52	6.22	7.12	6.52	6.22	4.12	-	-	4.12	-	-
Critical Hdwy Stg 1	6.12	5.52	-	6.12	5.52	-	-	-	-	-	-	-
Critical Hdwy Stg 2	6.12	5.52	-	6.12	5.52	-	-	-	-	-	-	-
Follow-up Hdwy	3.518	4.018	3.318	3.518	4.018	3.318	2.218	-	-	2.218	-	-
Pot Cap-1 Maneuver	518	561	1021	572	566	1008	1553	-	-	1531	-	-
Stage 1	721	675	-	940	837	-	-	-	-	-	-	-
Stage 2	836	827	-	694	672	-	-	-	-	-	-	-
Platoon blocked, %								-	-	-	-	-
Mov Cap-1 Maneuver	385	514	1021	490	518	1008	1553	-	-	1531	-	-
Mov Cap-2 Maneuver	385	514	-	490	518	-	-	-	-	-	-	-
Stage 1	718	621	-	936	834	-	-	-	-	-	-	-
Stage 2	672	824	-	580	618	-	-	-	-	-	-	-

Approach	EB		WB		NB		SB	
HCM Control Delay, s	12.3		12.4		0.6		5.2	
HCM LOS	B		B					

Minor Lane/Major Mvmt	NBL	NBT	NBR	EBLn1	WBLn1	SBL	SBT	SBR
Capacity (veh/h)	1553	-	-	555	714	1531	-	-
HCM Lane V/C Ratio	0.004	-	-	0.116	0.319	0.078	-	-
HCM Control Delay (s)	7.3	0	-	12.3	12.4	7.5	0	-
HCM Lane LOS	A	A	-	B	B	A	A	-
HCM 95th %tile Q(veh)	0	-	-	0.4	1.4	0.3	-	-

Heritage at Dalia Ranch
6: Imperial Ave & Worthington Rd/Barioni Blvd

Opening Year 2026 + P1-3 Proj
Timing Plan: PM PEAK

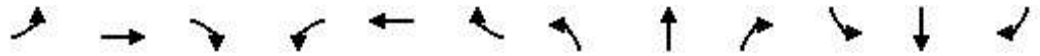

Movement	EBL	EBT	EBR	WBL	WBT	WBR	NBL	NBT	NBR	SBL	SBT	SBR
Lane Configurations		↕	↗		↕	↗	↗	↕↗		↗	↕↗	
Traffic Volume (veh/h)	65	77	109	57	117	93	117	966	15	62	818	74
Future Volume (veh/h)	65	77	109	57	117	93	117	966	15	62	818	74
Initial Q (Qb), veh	0	0	0	0	0	0	0	0	0	0	0	0
Ped-Bike Adj(A_pbT)	1.00		1.00	1.00		1.00	1.00		1.00	1.00		1.00
Parking Bus, Adj	1.00	1.00	1.00	1.00	1.00	1.00	1.00	1.00	1.00	1.00	1.00	1.00
Work Zone On Approach		No			No			No			No	
Adj Sat Flow, veh/h/ln	1870	1870	1870	1870	1870	1870	1870	1870	1870	1870	1870	1870
Adj Flow Rate, veh/h	71	85	120	63	129	102	129	1062	16	68	899	81
Peak Hour Factor	0.91	0.91	0.91	0.91	0.91	0.91	0.91	0.91	0.91	0.91	0.91	0.91
Percent Heavy Veh, %	2	2	2	2	2	2	2	2	2	2	2	2
Cap, veh/h	107	128	204	89	183	234	164	1197	18	101	984	89
Arrive On Green	0.13	0.13	0.13	0.15	0.15	0.15	0.09	0.33	0.33	0.06	0.30	0.30
Sat Flow, veh/h	832	996	1585	604	1236	1585	1781	3583	54	1781	3297	297
Grp Volume(v), veh/h	156	0	120	192	0	102	129	527	551	68	485	495
Grp Sat Flow(s),veh/h/ln	1829	0	1585	1840	0	1585	1781	1777	1861	1781	1777	1817
Q Serve(g_s), s	4.9	0.0	4.3	6.0	0.0	3.5	4.3	16.8	16.8	2.2	15.8	15.8
Cycle Q Clear(g_c), s	4.9	0.0	4.3	6.0	0.0	3.5	4.3	16.8	16.8	2.2	15.8	15.8
Prop In Lane	0.46		1.00	0.33		1.00	1.00		0.03	1.00		0.16
Lane Grp Cap(c), veh/h	235	0	204	272	0	234	164	594	622	101	530	542
V/C Ratio(X)	0.66	0.00	0.59	0.71	0.00	0.44	0.79	0.89	0.89	0.68	0.91	0.91
Avail Cap(c_a), veh/h	548	0	475	551	0	475	178	594	622	148	533	545
HCM Platoon Ratio	1.00	1.00	1.00	1.00	1.00	1.00	1.00	1.00	1.00	1.00	1.00	1.00
Upstream Filter(I)	1.00	0.00	1.00	1.00	0.00	1.00	1.00	1.00	1.00	1.00	1.00	1.00
Uniform Delay (d), s/veh	24.9	0.0	24.7	24.3	0.0	23.3	26.7	18.9	18.9	27.8	20.3	20.3
Incr Delay (d2), s/veh	3.2	0.0	2.7	3.3	0.0	1.3	19.2	15.1	14.6	7.7	20.3	19.9
Initial Q Delay(d3),s/veh	0.0	0.0	0.0	0.0	0.0	0.0	0.0	0.0	0.0	0.0	0.0	0.0
%ile BackOfQ(50%),veh/ln	2.2	0.0	1.7	2.7	0.0	1.3	2.6	8.6	8.9	1.1	8.9	9.0
Unsig. Movement Delay, s/veh												
LnGrp Delay(d),s/veh	28.1	0.0	27.4	27.7	0.0	24.6	45.9	34.0	33.5	35.5	40.6	40.2
LnGrp LOS	C	A	C	C	A	C	D	C	C	D	D	D
Approach Vol, veh/h		276			294			1207			1048	
Approach Delay, s/veh		27.8			26.6			35.0			40.1	
Approach LOS		C			C			D			D	
Timer - Assigned Phs	1	2		4	5	6		8				
Phs Duration (G+Y+Rc), s	8.4	25.1		12.7	10.5	22.9		13.9				
Change Period (Y+Rc), s	5.0	5.0		5.0	5.0	5.0		5.0				
Max Green Setting (Gmax), s	5.0	19.0		18.0	6.0	18.0		18.0				
Max Q Clear Time (g_c+I1), s	4.2	18.8		6.9	6.3	17.8		8.0				
Green Ext Time (p_c), s	0.0	0.1		0.9	0.0	0.1		1.0				
Intersection Summary												
HCM 6th Ctrl Delay			35.3									
HCM 6th LOS			D									

Intersection												
Intersection Delay, s/veh	12.2											
Intersection LOS	B											

Movement	EBL	EBT	EBR	WBL	WBT	WBR	NBL	NBT	NBR	SBL	SBT	SBR
Lane Configurations		↔	↔		↔	↔		↔			↔	
Traffic Vol, veh/h	66	210	34	28	233	35	1	0	0	39	5	59
Future Vol, veh/h	66	210	34	28	233	35	1	0	0	39	5	59
Peak Hour Factor	0.80	0.80	0.80	0.80	0.80	0.80	0.80	0.80	0.80	0.80	0.80	0.80
Heavy Vehicles, %	2	2	2	2	2	2	2	2	2	2	2	2
Mvmt Flow	83	263	43	35	291	44	1	0	0	49	6	74
Number of Lanes	0	1	1	0	1	1	0	1	0	0	1	0

Approach	EB	WB	NB	SB
Opposing Approach	WB	EB	SB	NB
Opposing Lanes	2	2	1	1
Conflicting Approach Left	SB	NB	EB	WB
Conflicting Lanes Left	1	1	2	2
Conflicting Approach Right	NB	SB	WB	EB
Conflicting Lanes Right	1	1	2	2
HCM Control Delay	13	12.3	9.3	9.8
HCM LOS	B	B	A	A

Lane	NBLn1	EBLn1	EBLn2	WBLn1	WBLn2	SBLn1
Vol Left, %	100%	24%	0%	11%	0%	38%
Vol Thru, %	0%	76%	0%	89%	0%	5%
Vol Right, %	0%	0%	100%	0%	100%	57%
Sign Control	Stop	Stop	Stop	Stop	Stop	Stop
Traffic Vol by Lane	1	276	34	261	35	103
LT Vol	1	66	0	28	0	39
Through Vol	0	210	0	233	0	5
RT Vol	0	0	34	0	35	59
Lane Flow Rate	1	345	42	326	44	129
Geometry Grp	2	7	7	7	7	2
Degree of Util (X)	0.002	0.512	0.053	0.48	0.055	0.194
Departure Headway (Hd)	6.276	5.343	4.518	5.297	4.538	5.421
Convergence, Y/N	Yes	Yes	Yes	Yes	Yes	Yes
Cap	574	669	786	675	782	657
Service Time	4.276	3.112	2.285	3.065	2.306	3.499
HCM Lane V/C Ratio	0.002	0.516	0.053	0.483	0.056	0.196
HCM Control Delay	9.3	13.7	7.5	12.9	7.6	9.8
HCM Lane LOS	A	B	A	B	A	A
HCM 95th-tile Q	0	2.9	0.2	2.6	0.2	0.7

Heritage at Dalia Ranch
8: Imperial Ave & Aten Rd

Opening Year 2026 + P1-3 Proj
Timing Plan: PM PEAK



Movement	EBL	EBT	EBR	WBL	WBT	WBR	NBL	NBT	NBR	SBL	SBT	SBR
Lane Configurations												
Traffic Volume (veh/h)	251	287	71	185	300	167	81	871	155	151	685	261
Future Volume (veh/h)	251	287	71	185	300	167	81	871	155	151	685	261
Initial Q (Qb), veh	0	0	0	0	0	0	0	0	0	0	0	0
Ped-Bike Adj(A_pbT)	1.00		1.00	1.00		1.00	1.00		1.00	1.00		1.00
Parking Bus, Adj	1.00	1.00	1.00	1.00	1.00	1.00	1.00	1.00	1.00	1.00	1.00	1.00
Work Zone On Approach		No		No		No		No		No		No
Adj Sat Flow, veh/h/ln	1870	1870	1870	1870	1870	1870	1870	1870	1870	1870	1870	1870
Adj Flow Rate, veh/h	267	305	76	197	319	178	86	927	165	161	729	278
Peak Hour Factor	0.94	0.94	0.94	0.94	0.94	0.94	0.94	0.94	0.94	0.94	0.94	0.94
Percent Heavy Veh, %	2	2	2	2	2	2	2	2	2	2	2	2
Cap, veh/h	278	601	147	239	423	231	110	959	428	177	1092	487
Arrive On Green	0.16	0.21	0.21	0.13	0.19	0.19	0.06	0.27	0.27	0.10	0.31	0.31
Sat Flow, veh/h	1781	2828	694	1781	2219	1210	1781	3554	1585	1781	3554	1585
Grp Volume(v), veh/h	267	190	191	197	254	243	86	927	165	161	729	278
Grp Sat Flow(s),veh/h/ln	1781	1777	1745	1781	1777	1652	1781	1777	1585	1781	1777	1585
Q Serve(g_s), s	10.5	6.6	6.8	7.6	9.5	9.8	3.4	18.1	6.0	6.3	12.6	10.4
Cycle Q Clear(g_c), s	10.5	6.6	6.8	7.6	9.5	9.8	3.4	18.1	6.0	6.3	12.6	10.4
Prop In Lane	1.00		0.40	1.00		0.73	1.00		1.00	1.00		1.00
Lane Grp Cap(c), veh/h	278	377	371	239	338	315	110	959	428	177	1092	487
V/C Ratio(X)	0.96	0.50	0.52	0.82	0.75	0.77	0.78	0.97	0.39	0.91	0.67	0.57
Avail Cap(c_a), veh/h	278	454	446	278	454	422	152	959	428	177	1092	487
HCM Platoon Ratio	1.00	1.00	1.00	1.00	1.00	1.00	1.00	1.00	1.00	1.00	1.00	1.00
Upstream Filter(l)	1.00	1.00	1.00	1.00	1.00	1.00	1.00	1.00	1.00	1.00	1.00	1.00
Uniform Delay (d), s/veh	29.5	24.4	24.5	29.7	26.9	27.0	32.5	25.4	21.0	31.4	21.3	20.5
Incr Delay (d2), s/veh	42.8	1.0	1.1	15.9	4.7	6.1	15.9	21.3	0.6	42.7	1.6	1.6
Initial Q Delay(d3),s/veh	0.0	0.0	0.0	0.0	0.0	0.0	0.0	0.0	0.0	0.0	0.0	0.0
%ile BackOfQ(50%),veh/ln	7.6	2.8	2.8	4.2	4.3	4.2	1.9	10.0	2.2	4.7	5.1	3.8
Unsig. Movement Delay, s/veh												
LnGrp Delay(d),s/veh	72.3	25.5	25.6	45.6	31.7	33.2	48.4	46.7	21.5	74.1	22.8	22.1
LnGrp LOS	E	C	C	D	C	C	D	D	C	E	C	C
Approach Vol, veh/h		648			694			1178			1168	
Approach Delay, s/veh		44.8			36.1			43.3			29.7	
Approach LOS		D			D			D			C	
Timer - Assigned Phs	1	2	3	4	5	6	7	8				
Phs Duration (G+Y+Rc), s	24.0	14.5	20.0	9.4	26.6	16.0	18.4					
Change Period (Y+Rc), s	5.0	5.0	5.0	5.0	5.0	5.0	5.0					
Max Green Setting (Gmax), s	19.0	11.0	18.0	6.0	20.0	11.0	18.0					
Max Q Clear Time (g_c+1/3), s	20.1	9.6	8.8	5.4	14.6	12.5	11.8					
Green Ext Time (p_c), s	0.0	0.0	0.1	1.5	0.0	2.7	0.0	1.6				

Intersection Summary

HCM 6th Ctrl Delay	37.9
HCM 6th LOS	D

Intersection						
Int Delay, s/veh	2.1					
Movement	EBL	EBT	WBT	WBR	SBL	SBR
Lane Configurations	↘	↑	↗		↘	↗
Traffic Vol, veh/h	8	44	61	59	34	5
Future Vol, veh/h	8	44	61	59	34	5
Conflicting Peds, #/hr	0	0	0	0	0	0
Sign Control	Free	Free	Free	Free	Stop	Stop
RT Channelized	-	None	-	None	-	None
Storage Length	50	-	-	-	0	0
Veh in Median Storage, #	-	0	0	-	0	-
Grade, %	-	0	0	-	0	-
Peak Hour Factor	92	92	92	92	92	92
Heavy Vehicles, %	2	2	2	2	2	2
Mvmt Flow	9	48	66	64	37	5

Major/Minor	Major1	Major2	Minor2		
Conflicting Flow All	130	0	-	0	164 98
Stage 1	-	-	-	-	98 -
Stage 2	-	-	-	-	66 -
Critical Hdwy	4.12	-	-	-	6.42 6.22
Critical Hdwy Stg 1	-	-	-	-	5.42 -
Critical Hdwy Stg 2	-	-	-	-	5.42 -
Follow-up Hdwy	2.218	-	-	-	3.518 3.318
Pot Cap-1 Maneuver	1455	-	-	-	827 958
Stage 1	-	-	-	-	926 -
Stage 2	-	-	-	-	957 -
Platoon blocked, %		-	-	-	
Mov Cap-1 Maneuver	1455	-	-	-	822 958
Mov Cap-2 Maneuver	-	-	-	-	822 -
Stage 1	-	-	-	-	920 -
Stage 2	-	-	-	-	957 -

Approach	EB	WB	SB
HCM Control Delay, s	1.2	0	9.5
HCM LOS			A

Minor Lane/Major Mvmt	EBL	EBT	WBT	WBR	SBLn1	SBLn2
Capacity (veh/h)	1455	-	-	-	822	958
HCM Lane V/C Ratio	0.006	-	-	-	0.045	0.006
HCM Control Delay (s)	7.5	-	-	-	9.6	8.8
HCM Lane LOS	A	-	-	-	A	A
HCM 95th %tile Q(veh)	0	-	-	-	0.1	0

Intersection						
Int Delay, s/veh	0.4					
Movement	WBL	WBR	NBT	NBR	SBL	SBT
Lane Configurations	↙	↗	↖		↙	↗
Traffic Vol, veh/h	5	0	48	8	0	51
Future Vol, veh/h	5	0	48	8	0	51
Conflicting Peds, #/hr	0	0	0	0	0	0
Sign Control	Stop	Stop	Free	Free	Free	Free
RT Channelized	-	None	-	None	-	None
Storage Length	0	0	-	-	50	-
Veh in Median Storage, #	0	-	0	-	-	0
Grade, %	0	-	0	-	-	0
Peak Hour Factor	92	92	92	92	92	92
Heavy Vehicles, %	2	2	2	2	2	2
Mvmt Flow	5	0	52	9	0	55

Major/Minor	Minor1	Major1	Major2		
Conflicting Flow All	112	57	0	0	61
Stage 1	57	-	-	-	-
Stage 2	55	-	-	-	-
Critical Hdwy	6.42	6.22	-	-	4.12
Critical Hdwy Stg 1	5.42	-	-	-	-
Critical Hdwy Stg 2	5.42	-	-	-	-
Follow-up Hdwy	3.518	3.318	-	-	2.218
Pot Cap-1 Maneuver	885	1009	-	-	1542
Stage 1	966	-	-	-	-
Stage 2	968	-	-	-	-
Platoon blocked, %					
Mov Cap-1 Maneuver	885	1009	-	-	1542
Mov Cap-2 Maneuver	885	-	-	-	-
Stage 1	966	-	-	-	-
Stage 2	968	-	-	-	-

Approach	WB	NB	SB
HCM Control Delay, s	9.1	0	0
HCM LOS	A		

Minor Lane/Major Mvmt	NBT	NBRWBLn1	WBLn2	SBL	SBT
Capacity (veh/h)	-	-	885	-	1542
HCM Lane V/C Ratio	-	-	0.006	-	-
HCM Control Delay (s)	-	-	9.1	0	0
HCM Lane LOS	-	-	A	A	A
HCM 95th %tile Q(veh)	-	-	0	-	0

Intersection						
Int Delay, s/veh	5.2					
Movement	EBT	EBR	WBL	WBT	NBL	NBR
Lane Configurations	↔		↔	↑	↔	↔
Traffic Vol, veh/h	38	0	92	38	0	53
Future Vol, veh/h	38	0	92	38	0	53
Conflicting Peds, #/hr	0	0	0	0	0	0
Sign Control	Free	Free	Free	Free	Stop	Stop
RT Channelized	-	None	-	None	-	None
Storage Length	-	-	50	-	0	0
Veh in Median Storage, #	0	-	-	0	0	-
Grade, %	0	-	-	0	0	-
Peak Hour Factor	92	92	92	92	92	92
Heavy Vehicles, %	2	2	2	2	2	2
Mvmt Flow	41	0	100	41	0	58

Major/Minor	Major1	Major2	Minor1		
Conflicting Flow All	0	0	41	0	282 41
Stage 1	-	-	-	-	41 -
Stage 2	-	-	-	-	241 -
Critical Hdwy	-	-	4.12	-	6.42 6.22
Critical Hdwy Stg 1	-	-	-	-	5.42 -
Critical Hdwy Stg 2	-	-	-	-	5.42 -
Follow-up Hdwy	-	-	2.218	-	3.518 3.318
Pot Cap-1 Maneuver	-	-	1568	-	708 1030
Stage 1	-	-	-	-	981 -
Stage 2	-	-	-	-	799 -
Platoon blocked, %	-	-	-	-	-
Mov Cap-1 Maneuver	-	-	1568	-	663 1030
Mov Cap-2 Maneuver	-	-	-	-	663 -
Stage 1	-	-	-	-	981 -
Stage 2	-	-	-	-	748 -

Approach	EB	WB	NB
HCM Control Delay, s	0	5.3	8.7
HCM LOS			A

Minor Lane/Major Mvmt	NBLn1	NBLn2	EBT	EBR	WBL	WBT
Capacity (veh/h)	-	1030	-	-	1568	-
HCM Lane V/C Ratio	-	0.056	-	-	0.064	-
HCM Control Delay (s)	0	8.7	-	-	7.5	-
HCM Lane LOS	A	A	-	-	A	-
HCM 95th %tile Q(veh)	-	0.2	-	-	0.2	-

Intersection						
Int Delay, s/veh	1.5					
Movement	EBT	EBR	WBL	WBT	NBL	NBR
Lane Configurations	↔		↔	↑	↔	↔
Traffic Vol, veh/h	87	4	33	128	2	17
Future Vol, veh/h	87	4	33	128	2	17
Conflicting Peds, #/hr	0	0	0	0	0	0
Sign Control	Free	Free	Free	Free	Stop	Stop
RT Channelized	-	None	-	None	-	None
Storage Length	-	-	50	-	0	0
Veh in Median Storage, #	0	-	-	0	0	-
Grade, %	0	-	-	0	0	-
Peak Hour Factor	92	92	92	92	92	92
Heavy Vehicles, %	2	2	2	2	2	2
Mvmt Flow	95	4	36	139	2	18

Major/Minor	Major1	Major2	Minor1		
Conflicting Flow All	0	0	99	0	308 97
Stage 1	-	-	-	-	97 -
Stage 2	-	-	-	-	211 -
Critical Hdwy	-	-	4.12	-	6.42 6.22
Critical Hdwy Stg 1	-	-	-	-	5.42 -
Critical Hdwy Stg 2	-	-	-	-	5.42 -
Follow-up Hdwy	-	-	2.218	-	3.518 3.318
Pot Cap-1 Maneuver	-	-	1494	-	684 959
Stage 1	-	-	-	-	927 -
Stage 2	-	-	-	-	824 -
Platoon blocked, %	-	-	-	-	-
Mov Cap-1 Maneuver	-	-	1494	-	668 959
Mov Cap-2 Maneuver	-	-	-	-	668 -
Stage 1	-	-	-	-	927 -
Stage 2	-	-	-	-	804 -

Approach	EB	WB	NB
HCM Control Delay, s	0	1.5	9
HCM LOS			A

Minor Lane/Major Mvmt	NBLn1	NBLn2	EBT	EBR	WBL	WBT
Capacity (veh/h)	668	959	-	-	1494	-
HCM Lane V/C Ratio	0.003	0.019	-	-	0.024	-
HCM Control Delay (s)	10.4	8.8	-	-	7.5	-
HCM Lane LOS	B	A	-	-	A	-
HCM 95th %tile Q(veh)	0	0.1	-	-	0.1	-

Intersection						
Int Delay, s/veh	6.5					
Movement	EBT	EBR	WBL	WBT	NBL	NBR
Lane Configurations	↔		↔	↑	↔	↔
Traffic Vol, veh/h	70	34	270	125	36	180
Future Vol, veh/h	70	34	270	125	36	180
Conflicting Peds, #/hr	0	0	0	0	0	0
Sign Control	Free	Free	Free	Free	Stop	Stop
RT Channelized	-	None	-	None	-	None
Storage Length	-	-	100	-	0	0
Veh in Median Storage, #	0	-	-	0	0	-
Grade, %	0	-	-	0	0	-
Peak Hour Factor	92	92	92	92	92	92
Heavy Vehicles, %	2	2	2	2	2	2
Mvmt Flow	76	37	293	136	39	196

Major/Minor	Major1	Major2	Minor1		
Conflicting Flow All	0	0	113	0	817 95
Stage 1	-	-	-	-	95 -
Stage 2	-	-	-	-	722 -
Critical Hdwy	-	-	4.12	-	6.42 6.22
Critical Hdwy Stg 1	-	-	-	-	5.42 -
Critical Hdwy Stg 2	-	-	-	-	5.42 -
Follow-up Hdwy	-	-	2.218	-	3.518 3.318
Pot Cap-1 Maneuver	-	-	1476	-	346 962
Stage 1	-	-	-	-	929 -
Stage 2	-	-	-	-	481 -
Platoon blocked, %	-	-	-	-	-
Mov Cap-1 Maneuver	-	-	1476	-	277 962
Mov Cap-2 Maneuver	-	-	-	-	277 -
Stage 1	-	-	-	-	929 -
Stage 2	-	-	-	-	385 -

Approach	EB	WB	NB
HCM Control Delay, s	0	5.5	11.4
HCM LOS			B

Minor Lane/Major Mvmt	NBLn1	NBLn2	EBT	EBR	WBL	WBT
Capacity (veh/h)	277	962	-	-	1476	-
HCM Lane V/C Ratio	0.141	0.203	-	-	0.199	-
HCM Control Delay (s)	20.1	9.7	-	-	8	-
HCM Lane LOS	C	A	-	-	A	-
HCM 95th %tile Q(veh)	0.5	0.8	-	-	0.7	-

Intersection						
Int Delay, s/veh	1					
Movement	EBL	EBR	NBL	NBT	SBT	SBR
Lane Configurations		↗		↕↕	↕↕	↗
Traffic Vol, veh/h	0	144	0	904	704	34
Future Vol, veh/h	0	144	0	904	704	34
Conflicting Peds, #/hr	0	0	0	0	0	0
Sign Control	Stop	Stop	Free	Free	Free	Free
RT Channelized	-	None	-	None	-	None
Storage Length	-	0	-	-	-	100
Veh in Median Storage, #	0	-	-	0	0	-
Grade, %	0	-	-	0	0	-
Peak Hour Factor	92	92	92	92	92	92
Heavy Vehicles, %	2	2	2	2	2	2
Mvmt Flow	0	157	0	983	765	37

Major/Minor	Minor2	Major1	Major2		
Conflicting Flow All	-	383	-	0	0
Stage 1	-	-	-	-	-
Stage 2	-	-	-	-	-
Critical Hdwy	-	6.94	-	-	-
Critical Hdwy Stg 1	-	-	-	-	-
Critical Hdwy Stg 2	-	-	-	-	-
Follow-up Hdwy	-	3.32	-	-	-
Pot Cap-1 Maneuver	0	615	0	-	-
Stage 1	0	-	0	-	-
Stage 2	0	-	0	-	-
Platoon blocked, %				-	-
Mov Cap-1 Maneuver	-	615	-	-	-
Mov Cap-2 Maneuver	-	-	-	-	-
Stage 1	-	-	-	-	-
Stage 2	-	-	-	-	-

Approach	EB	NB	SB
HCM Control Delay, s	12.8	0	0
HCM LOS	B		

Minor Lane/Major Mvmt	NBT	EBLn1	SBT	SBR
Capacity (veh/h)	-	615	-	-
HCM Lane V/C Ratio	-	0.255	-	-
HCM Control Delay (s)	-	12.8	-	-
HCM Lane LOS	-	B	-	-
HCM 95th %tile Q(veh)	-	1	-	-

Heritage at Dalia Ranch
1: SR-86 & Keystone Rd

Opening Year 2028
Timing Plan: AM PEAK



Movement	EBL	EBT	EBR	WBL	WBT	WBR	NBL	NBT	NBR	SBL	SBT	SBR
Lane Configurations		↕			↕		↗	↕	↗	↗	↕	↗
Traffic Volume (veh/h)	35	35	12	20	25	45	20	519	53	48	564	40
Future Volume (veh/h)	35	35	12	20	25	45	20	519	53	48	564	40
Initial Q (Qb), veh	0	0	0	0	0	0	0	0	0	0	0	0
Ped-Bike Adj(A_pbT)	1.00		1.00	1.00		1.00	1.00		1.00	1.00		1.00
Parking Bus, Adj	1.00	1.00	1.00	1.00	1.00	1.00	1.00	1.00	1.00	1.00	1.00	1.00
Work Zone On Approach		No			No			No			No	
Adj Sat Flow, veh/h/ln	1870	1870	1870	1870	1870	1870	1870	1870	1870	1870	1870	1870
Adj Flow Rate, veh/h	39	39	13	22	28	50	22	577	59	53	627	44
Peak Hour Factor	0.90	0.90	0.90	0.90	0.90	0.90	0.90	0.90	0.90	0.90	0.90	0.90
Percent Heavy Veh, %	2	2	2	2	2	2	2	2	2	2	2	2
Cap, veh/h	250	110	32	182	73	109	50	1095	488	106	1207	539
Arrive On Green	0.13	0.13	0.13	0.13	0.13	0.13	0.03	0.31	0.31	0.06	0.34	0.34
Sat Flow, veh/h	594	832	238	271	553	824	1781	3554	1585	1781	3554	1585
Grp Volume(v), veh/h	91	0	0	100	0	0	22	577	59	53	627	44
Grp Sat Flow(s),veh/h/ln	1664	0	0	1649	0	0	1781	1777	1585	1781	1777	1585
Q Serve(g_s), s	0.0	0.0	0.0	0.2	0.0	0.0	0.4	4.0	0.8	0.9	4.2	0.6
Cycle Q Clear(g_c), s	1.4	0.0	0.0	1.6	0.0	0.0	0.4	4.0	0.8	0.9	4.2	0.6
Prop In Lane	0.43		0.14	0.22		0.50	1.00		1.00	1.00		1.00
Lane Grp Cap(c), veh/h	392	0	0	365	0	0	50	1095	488	106	1207	539
V/C Ratio(X)	0.23	0.00	0.00	0.27	0.00	0.00	0.44	0.53	0.12	0.50	0.52	0.08
Avail Cap(c_a), veh/h	1117	0	0	1109	0	0	297	2131	950	297	2131	950
HCM Platoon Ratio	1.00	1.00	1.00	1.00	1.00	1.00	1.00	1.00	1.00	1.00	1.00	1.00
Upstream Filter(l)	1.00	0.00	0.00	1.00	0.00	0.00	1.00	1.00	1.00	1.00	1.00	1.00
Uniform Delay (d), s/veh	11.9	0.0	0.0	12.0	0.0	0.0	14.4	8.6	7.5	13.7	7.9	6.7
Incr Delay (d2), s/veh	0.3	0.0	0.0	0.4	0.0	0.0	6.1	0.4	0.1	3.6	0.3	0.1
Initial Q Delay(d3),s/veh	0.0	0.0	0.0	0.0	0.0	0.0	0.0	0.0	0.0	0.0	0.0	0.0
%ile BackOfQ(50%),veh/ln	0.4	0.0	0.0	0.5	0.0	0.0	0.2	1.1	0.2	0.4	1.1	0.1
Unsig. Movement Delay, s/veh												
LnGrp Delay(d),s/veh	12.2	0.0	0.0	12.4	0.0	0.0	20.4	9.0	7.6	17.3	8.3	6.8
LnGrp LOS	B	A	A	B	A	A	C	A	A	B	A	A
Approach Vol, veh/h		91			100			658			724	
Approach Delay, s/veh		12.2			12.4			9.2			8.9	
Approach LOS		B			B			A			A	
Timer - Assigned Phs	1	2		4	5	6		8				
Phs Duration (G+Y+Rc), s	6.8	14.3		9.0	5.8	15.2		9.0				
Change Period (Y+Rc), s	5.0	5.0		5.0	5.0	5.0		5.0				
Max Green Setting (Gmax), s	5.0	18.0		18.0	5.0	18.0		18.0				
Max Q Clear Time (g_c+I1), s	2.9	6.0		3.4	2.4	6.2		3.6				
Green Ext Time (p_c), s	0.0	3.2		0.3	0.0	3.4		0.4				
Intersection Summary												
HCM 6th Ctrl Delay				9.4								
HCM 6th LOS				A								

Intersection												
Int Delay, s/veh	0.4											
Movement	EBL	EBT	EBR	WBL	WBT	WBR	NBL	NBT	NBR	SBL	SBT	SBR
Lane Configurations		↕			↕		↕	↕		↕	↕	
Traffic Vol, veh/h	21	3	2	1	2	6	0	590	1	1	569	8
Future Vol, veh/h	21	3	2	1	2	6	0	590	1	1	569	8
Conflicting Peds, #/hr	0	0	0	0	0	0	0	0	0	0	0	0
Sign Control	Stop	Stop	Stop	Stop	Stop	Stop	Free	Free	Free	Free	Free	Free
RT Channelized	-	-	None	-	-	None	-	-	None	-	-	None
Storage Length	-	-	-	-	-	-	50	-	-	50	-	-
Veh in Median Storage, #	-	1	-	-	1	-	-	0	-	-	0	-
Grade, %	-	0	-	-	0	-	-	0	-	-	0	-
Peak Hour Factor	94	94	94	94	94	94	94	94	94	94	94	94
Heavy Vehicles, %	2	2	2	2	2	2	2	2	2	2	2	2
Mvmt Flow	22	3	2	1	2	6	0	628	1	1	605	9

Major/Minor	Minor2		Minor1		Major1			Major2				
Conflicting Flow All	927	1241	307	935	1245	315	614	0	0	629	0	0
Stage 1	612	612	-	629	629	-	-	-	-	-	-	-
Stage 2	315	629	-	306	616	-	-	-	-	-	-	-
Critical Hdwy	7.54	6.54	6.94	7.54	6.54	6.94	4.14	-	-	4.14	-	-
Critical Hdwy Stg 1	6.54	5.54	-	6.54	5.54	-	-	-	-	-	-	-
Critical Hdwy Stg 2	6.54	5.54	-	6.54	5.54	-	-	-	-	-	-	-
Follow-up Hdwy	3.52	4.02	3.32	3.52	4.02	3.32	2.22	-	-	2.22	-	-
Pot Cap-1 Maneuver	223	174	689	220	173	681	961	-	-	949	-	-
Stage 1	447	482	-	437	474	-	-	-	-	-	-	-
Stage 2	671	474	-	679	480	-	-	-	-	-	-	-
Platoon blocked, %								-	-	-	-	-
Mov Cap-1 Maneuver	219	174	689	217	173	681	961	-	-	949	-	-
Mov Cap-2 Maneuver	337	297	-	333	297	-	-	-	-	-	-	-
Stage 1	447	482	-	437	474	-	-	-	-	-	-	-
Stage 2	662	474	-	672	480	-	-	-	-	-	-	-

Approach	EB		WB		NB		SB	
HCM Control Delay, s	16.3		12.6		0		0	
HCM LOS	C		B					

Minor Lane/Major Mvmt	NBL	NBT	NBR	EBLn1	WBLn1	SBL	SBT	SBR
Capacity (veh/h)	961	-	-	345	485	949	-	-
HCM Lane V/C Ratio	-	-	-	0.08	0.02	0.001	-	-
HCM Control Delay (s)	0	-	-	16.3	12.6	8.8	-	-
HCM Lane LOS	A	-	-	C	B	A	-	-
HCM 95th %tile Q(veh)	0	-	-	0.3	0.1	0	-	-

Intersection						
Int Delay, s/veh	5.3					
Movement	WBL	WBR	NBT	NBR	SBL	SBT
Lane Configurations	TT		TT		T	TT
Traffic Vol, veh/h	127	45	546	63	27	545
Future Vol, veh/h	127	45	546	63	27	545
Conflicting Peds, #/hr	0	0	0	0	0	0
Sign Control	Stop	Stop	Free	Free	Free	Free
RT Channelized	-	None	-	None	-	None
Storage Length	0	-	-	-	140	-
Veh in Median Storage, #	0	-	0	-	-	0
Grade, %	0	-	0	-	-	0
Peak Hour Factor	91	91	91	91	91	91
Heavy Vehicles, %	2	2	2	2	2	2
Mvmt Flow	140	49	600	69	30	599

Major/Minor	Minor1	Major1	Major2		
Conflicting Flow All	995	335	0	0	669
Stage 1	635	-	-	-	-
Stage 2	360	-	-	-	-
Critical Hdwy	6.84	6.94	-	-	4.14
Critical Hdwy Stg 1	5.84	-	-	-	-
Critical Hdwy Stg 2	5.84	-	-	-	-
Follow-up Hdwy	3.52	3.32	-	-	2.22
Pot Cap-1 Maneuver	242	661	-	-	917
Stage 1	490	-	-	-	-
Stage 2	677	-	-	-	-
Platoon blocked, %			-	-	-
Mov Cap-1 Maneuver	234	661	-	-	917
Mov Cap-2 Maneuver	234	-	-	-	-
Stage 1	490	-	-	-	-
Stage 2	655	-	-	-	-

Approach	WB	NB	SB
HCM Control Delay, s	40.3	0	0.4
HCM LOS	E		

Minor Lane/Major Mvmt	NBT	NBRWBLn1	SBL	SBT
Capacity (veh/h)	-	-	282	917
HCM Lane V/C Ratio	-	-	0.67	0.032
HCM Control Delay (s)	-	-	40.3	9.1
HCM Lane LOS	-	-	E	A
HCM 95th %tile Q(veh)	-	-	4.4	0.1

Heritage at Dalia Ranch
4: Imperial Ave & Neckel Rd

Opening Year 2028
Timing Plan: AM PEAK

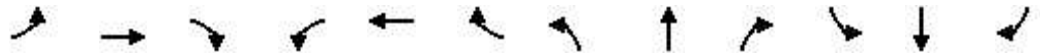

Movement	EBL	EBT	EBR	WBL	WBT	WBR	NBL	NBT	NBR	SBL	SBT	SBR
Lane Configurations		↕			↕		↕	↕		↕	↕	
Traffic Volume (veh/h)	36	46	13	232	68	87	9	493	96	24	612	33
Future Volume (veh/h)	36	46	13	232	68	87	9	493	96	24	612	33
Initial Q (Qb), veh	0	0	0	0	0	0	0	0	0	0	0	0
Ped-Bike Adj(A_pbT)	1.00		1.00	1.00		1.00	1.00		1.00	1.00		1.00
Parking Bus, Adj	1.00	1.00	1.00	1.00	1.00	1.00	1.00	1.00	1.00	1.00	1.00	1.00
Work Zone On Approach		No			No			No			No	
Adj Sat Flow, veh/h/ln	1870	1870	1870	1870	1870	1870	1870	1870	1870	1870	1870	1870
Adj Flow Rate, veh/h	40	51	14	255	75	96	10	542	105	26	673	36
Peak Hour Factor	0.91	0.91	0.91	0.91	0.91	0.91	0.91	0.91	0.91	0.91	0.91	0.91
Percent Heavy Veh, %	2	2	2	2	2	2	2	2	2	2	2	2
Cap, veh/h	55	70	19	295	87	111	23	737	142	53	910	49
Arrive On Green	0.08	0.08	0.08	0.28	0.28	0.28	0.01	0.25	0.25	0.03	0.27	0.27
Sat Flow, veh/h	683	871	239	1046	308	394	1781	2971	573	1781	3431	183
Grp Volume(v), veh/h	105	0	0	426	0	0	10	323	324	26	348	361
Grp Sat Flow(s),veh/h/ln	1793	0	0	1747	0	0	1781	1777	1767	1781	1777	1837
Q Serve(g_s), s	3.2	0.0	0.0	12.9	0.0	0.0	0.3	9.3	9.4	0.8	10.0	10.0
Cycle Q Clear(g_c), s	3.2	0.0	0.0	12.9	0.0	0.0	0.3	9.3	9.4	0.8	10.0	10.0
Prop In Lane	0.38		0.13	0.60		0.23	1.00		0.32	1.00		0.10
Lane Grp Cap(c), veh/h	143	0	0	492	0	0	23	441	439	53	471	487
V/C Ratio(X)	0.73	0.00	0.00	0.87	0.00	0.00	0.44	0.73	0.74	0.49	0.74	0.74
Avail Cap(c_a), veh/h	581	0	0	566	0	0	160	608	605	160	608	629
HCM Platoon Ratio	1.00	1.00	1.00	1.00	1.00	1.00	1.00	1.00	1.00	1.00	1.00	1.00
Upstream Filter(I)	1.00	0.00	0.00	1.00	0.00	0.00	1.00	1.00	1.00	1.00	1.00	1.00
Uniform Delay (d), s/veh	25.0	0.0	0.0	18.9	0.0	0.0	27.2	19.2	19.2	26.5	18.6	18.7
Incr Delay (d2), s/veh	7.0	0.0	0.0	12.0	0.0	0.0	12.5	2.9	3.1	6.9	3.5	3.4
Initial Q Delay(d3),s/veh	0.0	0.0	0.0	0.0	0.0	0.0	0.0	0.0	0.0	0.0	0.0	0.0
%ile BackOfQ(50%),veh/ln	1.5	0.0	0.0	6.3	0.0	0.0	0.2	3.8	3.8	0.4	4.1	4.3
Unsig. Movement Delay, s/veh												
LnGrp Delay(d),s/veh	32.0	0.0	0.0	30.9	0.0	0.0	39.7	22.1	22.3	33.4	22.1	22.1
LnGrp LOS	C	A	A	C	A	A	D	C	C	C	C	C
Approach Vol, veh/h		105			426			657				735
Approach Delay, s/veh		32.0			30.9			22.4				22.5
Approach LOS		C			C			C				C
Timer - Assigned Phs	1	2		4	5	6		8				
Phs Duration (G+Y+Rc), s	6.7	18.8		9.4	5.7	19.7		20.7				
Change Period (Y+Rc), s	5.0	5.0		5.0	5.0	5.0		5.0				
Max Green Setting (Gmax), s	5.0	19.0		18.0	5.0	19.0		18.0				
Max Q Clear Time (g_c+I1), s	2.8	11.4		5.2	2.3	12.0		14.9				
Green Ext Time (p_c), s	0.0	2.4		0.4	0.0	2.5		0.8				
Intersection Summary												
HCM 6th Ctrl Delay				24.9								
HCM 6th LOS				C								

Intersection												
Int Delay, s/veh	7.7											
Movement	EBL	EBT	EBR	WBL	WBT	WBR	NBL	NBT	NBR	SBL	SBT	SBR
Lane Configurations		↕			↕			↕			↕	
Traffic Vol, veh/h	4	44	24	64	47	0	8	7	45	1	2	1
Future Vol, veh/h	4	44	24	64	47	0	8	7	45	1	2	1
Conflicting Peds, #/hr	0	0	0	0	0	0	0	0	0	0	0	0
Sign Control	Stop	Stop	Stop	Stop	Stop	Stop	Free	Free	Free	Free	Free	Free
RT Channelized	-	-	None	-	-	None	-	-	None	-	-	None
Storage Length	-	-	-	-	-	-	-	-	-	-	-	-
Veh in Median Storage, #	-	0	-	-	0	-	-	0	-	-	0	-
Grade, %	-	0	-	-	0	-	-	0	-	-	0	-
Peak Hour Factor	79	79	79	79	79	79	79	79	79	79	79	79
Heavy Vehicles, %	2	2	2	2	2	2	2	2	2	2	2	2
Mvmt Flow	5	56	30	81	59	0	10	9	57	1	3	1

Major/Minor	Minor2		Minor1		Major1			Major2				
Conflicting Flow All	93	92	4	107	64	38	4	0	0	66	0	0
Stage 1	6	6	-	58	58	-	-	-	-	-	-	-
Stage 2	87	86	-	49	6	-	-	-	-	-	-	-
Critical Hdwy	7.12	6.52	6.22	7.12	6.52	6.22	4.12	-	-	4.12	-	-
Critical Hdwy Stg 1	6.12	5.52	-	6.12	5.52	-	-	-	-	-	-	-
Critical Hdwy Stg 2	6.12	5.52	-	6.12	5.52	-	-	-	-	-	-	-
Follow-up Hdwy	3.518	4.018	3.318	3.518	4.018	3.318	2.218	-	-	2.218	-	-
Pot Cap-1 Maneuver	891	798	1080	872	827	1034	1618	-	-	1536	-	-
Stage 1	1016	891	-	954	847	-	-	-	-	-	-	-
Stage 2	921	824	-	964	891	-	-	-	-	-	-	-
Platoon blocked, %								-	-	-	-	-
Mov Cap-1 Maneuver	838	792	1080	798	821	1034	1618	-	-	1536	-	-
Mov Cap-2 Maneuver	838	792	-	798	821	-	-	-	-	-	-	-
Stage 1	1010	890	-	948	842	-	-	-	-	-	-	-
Stage 2	851	819	-	877	890	-	-	-	-	-	-	-

Approach	EB		WB		NB		SB	
HCM Control Delay, s	9.6		10.4		1		1.8	
HCM LOS	A		B					

Minor Lane/Major Mvmt	NBL	NBT	NBR	EBLn1	WBLn1	SBL	SBT	SBR
Capacity (veh/h)	1618	-	-	872	808	1536	-	-
HCM Lane V/C Ratio	0.006	-	-	0.105	0.174	0.001	-	-
HCM Control Delay (s)	7.2	0	-	9.6	10.4	7.3	0	-
HCM Lane LOS	A	A	-	A	B	A	A	-
HCM 95th %tile Q(veh)	0	-	-	0.3	0.6	0	-	-

Heritage at Dalia Ranch
6: Imperial Ave & Worthington Rd/Barioni Blvd

Opening Year 2028
Timing Plan: AM PEAK



Movement	EBL	EBT	EBR	WBL	WBT	WBR	NBL	NBT	NBR	SBL	SBT	SBR
Lane Configurations		↕	↗		↕	↗	↗	↕↗		↗	↕↗	
Traffic Volume (veh/h)	83	145	227	58	141	83	99	537	54	42	796	84
Future Volume (veh/h)	83	145	227	58	141	83	99	537	54	42	796	84
Initial Q (Qb), veh	0	0	0	0	0	0	0	0	0	0	0	0
Ped-Bike Adj(A_pbT)	1.00		1.00	1.00		1.00	1.00		1.00	1.00		1.00
Parking Bus, Adj	1.00	1.00	1.00	1.00	1.00	1.00	1.00	1.00	1.00	1.00	1.00	1.00
Work Zone On Approach		No			No			No			No	
Adj Sat Flow, veh/h/ln	1870	1870	1870	1870	1870	1870	1870	1870	1870	1870	1870	1870
Adj Flow Rate, veh/h	93	163	255	65	158	93	111	603	61	47	894	94
Peak Hour Factor	0.89	0.89	0.89	0.89	0.89	0.89	0.89	0.89	0.89	0.89	0.89	0.89
Percent Heavy Veh, %	2	2	2	2	2	2	2	2	2	2	2	2
Cap, veh/h	134	234	317	85	207	251	130	999	101	77	899	94
Arrive On Green	0.20	0.20	0.20	0.16	0.16	0.16	0.07	0.31	0.31	0.04	0.28	0.28
Sat Flow, veh/h	667	1170	1585	537	1306	1585	1781	3259	329	1781	3245	341
Grp Volume(v), veh/h	256	0	255	223	0	93	111	328	336	47	490	498
Grp Sat Flow(s),veh/h/ln	1837	0	1585	1843	0	1585	1781	1777	1811	1781	1777	1809
Q Serve(g_s), s	8.9	0.0	10.5	7.9	0.0	3.6	4.2	10.8	10.8	1.8	18.9	18.9
Cycle Q Clear(g_c), s	8.9	0.0	10.5	7.9	0.0	3.6	4.2	10.8	10.8	1.8	18.9	18.9
Prop In Lane	0.36		1.00	0.29		1.00	1.00		0.18	1.00		0.19
Lane Grp Cap(c), veh/h	368	0	317	292	0	251	130	545	555	77	492	501
V/C Ratio(X)	0.70	0.00	0.80	0.76	0.00	0.37	0.86	0.60	0.60	0.61	0.99	0.99
Avail Cap(c_a), veh/h	482	0	416	484	0	416	130	545	555	130	492	501
HCM Platoon Ratio	1.00	1.00	1.00	1.00	1.00	1.00	1.00	1.00	1.00	1.00	1.00	1.00
Upstream Filter(l)	1.00	0.00	1.00	1.00	0.00	1.00	1.00	1.00	1.00	1.00	1.00	1.00
Uniform Delay (d), s/veh	25.5	0.0	26.2	27.6	0.0	25.8	31.4	20.2	20.2	32.3	24.8	24.8
Incr Delay (d2), s/veh	2.9	0.0	8.4	4.1	0.0	0.9	39.4	1.9	1.9	7.6	39.2	38.8
Initial Q Delay(d3),s/veh	0.0	0.0	0.0	0.0	0.0	0.0	0.0	0.0	0.0	0.0	0.0	0.0
%ile BackOfQ(50%),veh/ln	4.0	0.0	4.5	3.7	0.0	1.4	3.2	4.4	4.5	0.9	12.7	12.9
Unsig. Movement Delay, s/veh												
LnGrp Delay(d),s/veh	28.4	0.0	34.5	31.7	0.0	26.7	70.8	22.1	22.1	39.9	63.9	63.6
LnGrp LOS	C	A	C	C	A	C	E	C	C	D	E	E
Approach Vol, veh/h		511			316			775			1035	
Approach Delay, s/veh		31.5			30.3			29.1			62.7	
Approach LOS		C			C			C			E	
Timer - Assigned Phs	1	2		4	5	6		8				
Phs Duration (G+Y+Rc), s	8.0	26.0		18.7	10.0	24.0		15.9				
Change Period (Y+Rc), s	5.0	5.0		5.0	5.0	5.0		5.0				
Max Green Setting (Gmax), s	5.0	19.0		18.0	5.0	19.0		18.0				
Max Q Clear Time (g_c+I1), s	3.8	12.8		12.5	6.2	20.9		9.9				
Green Ext Time (p_c), s	0.0	2.1		1.2	0.0	0.0		1.0				
Intersection Summary												
HCM 6th Ctrl Delay				42.9								
HCM 6th LOS				D								

Intersection

Intersection Delay, s/veh25.7

Intersection LOS D

Movement	EBL	EBT	EBR	WBL	WBT	WBR	NBL	NBT	NBR	SBL	SBT	SBR
Lane Configurations		↔	↔		↔	↔		↔			↔	
Traffic Vol, veh/h	65	426	128	12	347	83	0	0	1	114	33	68
Future Vol, veh/h	65	426	128	12	347	83	0	0	1	114	33	68
Peak Hour Factor	0.92	0.92	0.92	0.92	0.92	0.92	0.92	0.92	0.92	0.92	0.92	0.92
Heavy Vehicles, %	2	2	2	2	2	2	2	2	2	2	2	2
Mvmt Flow	71	463	139	13	377	90	0	0	1	124	36	74
Number of Lanes	0	1	1	0	1	1	0	1	0	0	1	0

Approach	EB	WB	NB	SB
Opposing Approach	WB	EB	SB	NB
Opposing Lanes	2	2	1	1
Conflicting Approach Left	SB	NB	EB	WB
Conflicting Lanes Left	1	1	2	2
Conflicting Approach Right	NB	SB	WB	EB
Conflicting Lanes Right	1	1	2	2
HCM Control Delay	34.5	19	10	14.3
HCM LOS	D	C	A	B

Lane	NBLn1	EBLn1	EBLn2	WBLn1	WBLn2	SBLn1
Vol Left, %	0%	13%	0%	3%	0%	53%
Vol Thru, %	0%	87%	0%	97%	0%	15%
Vol Right, %	100%	0%	100%	0%	100%	32%
Sign Control	Stop	Stop	Stop	Stop	Stop	Stop
Traffic Vol by Lane	1	491	128	359	83	215
LT Vol	0	65	0	12	0	114
Through Vol	0	426	0	347	0	33
RT Vol	1	0	128	0	83	68
Lane Flow Rate	1	534	139	390	90	234
Geometry Grp	2	7	7	7	7	2
Degree of Util (X)	0.002	0.9	0.205	0.678	0.138	0.423
Departure Headway (Hd)	6.988	6.074	5.295	6.253	5.524	6.523
Convergence, Y/N	Yes	Yes	Yes	Yes	Yes	Yes
Cap	515	598	675	578	646	549
Service Time	4.988	3.828	3.05	4.016	3.287	4.588
HCM Lane V/C Ratio	0.002	0.893	0.206	0.675	0.139	0.426
HCM Control Delay	10	41	9.4	21.3	9.2	14.3
HCM Lane LOS	A	E	A	C	A	B
HCM 95th-tile Q	0	10.9	0.8	5.2	0.5	2.1

Heritage at Dalia Ranch
8: Imperial Ave & Aten Rd

Opening Year 2028
Timing Plan: AM PEAK



Movement	EBL	EBT	EBR	WBL	WBT	WBR	NBL	NBT	NBR	SBL	SBT	SBR
Lane Configurations												
Traffic Volume (veh/h)	208	362	67	140	321	151	65	399	72	152	815	426
Future Volume (veh/h)	208	362	67	140	321	151	65	399	72	152	815	426
Initial Q (Qb), veh	0	0	0	0	0	0	0	0	0	0	0	0
Ped-Bike Adj(A_pbT)	1.00		1.00	1.00		1.00	1.00		1.00	1.00		1.00
Parking Bus, Adj	1.00	1.00	1.00	1.00	1.00	1.00	1.00	1.00	1.00	1.00	1.00	1.00
Work Zone On Approach		No		No		No		No		No		No
Adj Sat Flow, veh/h/ln	1870	1870	1870	1870	1870	1870	1870	1870	1870	1870	1870	1870
Adj Flow Rate, veh/h	242	421	78	163	373	176	76	464	84	177	948	495
Peak Hour Factor	0.86	0.86	0.86	0.86	0.86	0.86	0.86	0.86	0.86	0.86	0.86	0.86
Percent Heavy Veh, %	2	2	2	2	2	2	2	2	2	2	2	2
Cap, veh/h	279	740	136	202	479	223	98	854	381	203	1064	475
Arrive On Green	0.16	0.25	0.25	0.11	0.20	0.20	0.06	0.24	0.24	0.11	0.30	0.30
Sat Flow, veh/h	1781	2997	551	1781	2355	1095	1781	3554	1585	1781	3554	1585
Grp Volume(v), veh/h	242	248	251	163	280	269	76	464	84	177	948	495
Grp Sat Flow(s),veh/h/ln	1781	1777	1771	1781	1777	1673	1781	1777	1585	1781	1777	1585
Q Serve(g_s), s	9.3	8.6	8.7	6.3	10.4	10.7	3.0	8.0	3.0	6.9	17.9	21.0
Cycle Q Clear(g_c), s	9.3	8.6	8.7	6.3	10.4	10.7	3.0	8.0	3.0	6.9	17.9	21.0
Prop In Lane	1.00		0.31	1.00		0.65	1.00		1.00	1.00		1.00
Lane Grp Cap(c), veh/h	279	439	438	202	362	341	98	854	381	203	1064	475
V/C Ratio(X)	0.87	0.57	0.57	0.81	0.77	0.79	0.77	0.54	0.22	0.87	0.89	1.04
Avail Cap(c_a), veh/h	279	507	505	229	456	429	127	912	407	203	1064	475
HCM Platoon Ratio	1.00	1.00	1.00	1.00	1.00	1.00	1.00	1.00	1.00	1.00	1.00	1.00
Upstream Filter(l)	1.00	1.00	1.00	1.00	1.00	1.00	1.00	1.00	1.00	1.00	1.00	1.00
Uniform Delay (d), s/veh	28.9	23.1	23.2	30.3	26.4	26.5	32.7	23.3	21.4	30.6	23.5	24.6
Incr Delay (d2), s/veh	23.7	1.1	1.2	17.2	6.3	7.6	19.6	0.6	0.3	31.1	9.6	53.0
Initial Q Delay(d3),s/veh	0.0	0.0	0.0	0.0	0.0	0.0	0.0	0.0	0.0	0.0	0.0	0.0
%ile BackOfQ(50%),veh/ln	5.6	3.5	3.6	3.5	4.8	4.8	1.8	3.2	1.1	4.6	8.4	14.3
Unsig. Movement Delay, s/veh												
LnGrp Delay(d),s/veh	52.5	24.3	24.3	47.5	32.7	34.1	52.3	23.8	21.7	61.7	33.1	77.6
LnGrp LOS	D	C	C	D	C	C	D	C	C	E	C	F
Approach Vol, veh/h		741			712			624			1620	
Approach Delay, s/veh		33.5			36.6			27.0			49.8	
Approach LOS		C			D			C			D	
Timer - Assigned Phs	1	2	3	4	5	6	7	8				
Phs Duration (G+Y+Rc), s	13.0	21.9	12.9	22.3	8.9	26.0	16.0	19.3				
Change Period (Y+Rc), s	5.0	5.0	5.0	5.0	5.0	5.0	5.0	5.0				
Max Green Setting (Gmax), s	18.0	18.0	9.0	20.0	5.0	21.0	11.0	18.0				
Max Q Clear Time (g_c+1/3), s	10.0	10.0	8.3	10.7	5.0	23.0	11.3	12.7				
Green Ext Time (p_c), s	0.0	2.1	0.0	2.1	0.0	0.0	0.0	1.6				

Intersection Summary

HCM 6th Ctrl Delay	40.2
HCM 6th LOS	D

Heritage at Dalia Ranch
1: SR-86 & Keystone Rd

Opening Year 2028
Timing Plan: PM PEAK

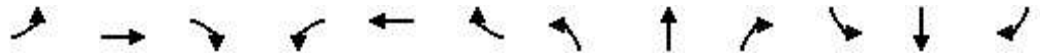

Movement	EBL	EBT	EBR	WBL	WBT	WBR	NBL	NBT	NBR	SBL	SBT	SBR
Lane Configurations		↔			↔		↗	↕	↗	↗	↕	↗
Traffic Volume (veh/h)	44	13	21	35	29	40	11	591	28	56	632	36
Future Volume (veh/h)	44	13	21	35	29	40	11	591	28	56	632	36
Initial Q (Qb), veh	0	0	0	0	0	0	0	0	0	0	0	0
Ped-Bike Adj(A_pbT)	1.00		1.00	1.00		1.00	1.00		1.00	1.00		1.00
Parking Bus, Adj	1.00	1.00	1.00	1.00	1.00	1.00	1.00	1.00	1.00	1.00	1.00	1.00
Work Zone On Approach		No			No			No			No	
Adj Sat Flow, veh/h/ln	1870	1870	1870	1870	1870	1870	1870	1870	1870	1870	1870	1870
Adj Flow Rate, veh/h	49	15	24	39	33	45	12	664	31	63	710	40
Peak Hour Factor	0.89	0.89	0.89	0.89	0.89	0.89	0.89	0.89	0.89	0.89	0.89	0.89
Percent Heavy Veh, %	2	2	2	2	2	2	2	2	2	2	2	2
Cap, veh/h	276	52	58	208	73	83	28	1200	535	119	1382	616
Arrive On Green	0.13	0.13	0.13	0.13	0.13	0.13	0.02	0.34	0.34	0.07	0.39	0.39
Sat Flow, veh/h	785	400	445	452	561	633	1781	3554	1585	1781	3554	1585
Grp Volume(v), veh/h	88	0	0	117	0	0	12	664	31	63	710	40
Grp Sat Flow(s),veh/h/ln	1630	0	0	1647	0	0	1781	1777	1585	1781	1777	1585
Q Serve(g_s), s	0.0	0.0	0.0	0.6	0.0	0.0	0.2	4.9	0.4	1.1	4.9	0.5
Cycle Q Clear(g_c), s	1.4	0.0	0.0	2.0	0.0	0.0	0.2	4.9	0.4	1.1	4.9	0.5
Prop In Lane	0.56		0.27	0.33		0.38	1.00		1.00	1.00		1.00
Lane Grp Cap(c), veh/h	386	0	0	363	0	0	28	1200	535	119	1382	616
V/C Ratio(X)	0.23	0.00	0.00	0.32	0.00	0.00	0.43	0.55	0.06	0.53	0.51	0.06
Avail Cap(c_a), veh/h	1011	0	0	1035	0	0	276	2314	1032	331	2424	1081
HCM Platoon Ratio	1.00	1.00	1.00	1.00	1.00	1.00	1.00	1.00	1.00	1.00	1.00	1.00
Upstream Filter(l)	1.00	0.00	0.00	1.00	0.00	0.00	1.00	1.00	1.00	1.00	1.00	1.00
Uniform Delay (d), s/veh	12.8	0.0	0.0	13.1	0.0	0.0	15.7	8.7	7.2	14.6	7.5	6.2
Incr Delay (d2), s/veh	0.3	0.0	0.0	0.5	0.0	0.0	9.9	0.4	0.0	3.6	0.3	0.0
Initial Q Delay(d3),s/veh	0.0	0.0	0.0	0.0	0.0	0.0	0.0	0.0	0.0	0.0	0.0	0.0
%ile BackOfQ(50%),veh/ln	0.5	0.0	0.0	0.7	0.0	0.0	0.1	1.3	0.1	0.5	1.2	0.1
Unsig. Movement Delay, s/veh												
LnGrp Delay(d),s/veh	13.1	0.0	0.0	13.6	0.0	0.0	25.6	9.1	7.3	18.2	7.8	6.2
LnGrp LOS	B	A	A	B	A	A	C	A	A	B	A	A
Approach Vol, veh/h		88			117			707			813	
Approach Delay, s/veh		13.1			13.6			9.3			8.5	
Approach LOS		B			B			A			A	
Timer - Assigned Phs	1	2		4	5	6		8				
Phs Duration (G+Y+Rc), s	7.2	15.9		9.2	5.5	17.5		9.2				
Change Period (Y+Rc), s	5.0	5.0		5.0	5.0	5.0		5.0				
Max Green Setting (Gmax), s	6.0	21.0		18.0	5.0	22.0		18.0				
Max Q Clear Time (g_c+I1), s	3.1	6.9		3.4	2.2	6.9		4.0				
Green Ext Time (p_c), s	0.0	4.0		0.3	0.0	4.5		0.5				
Intersection Summary												
HCM 6th Ctrl Delay				9.4								
HCM 6th LOS				A								

Intersection												
Int Delay, s/veh	0.4											
Movement	EBL	EBT	EBR	WBL	WBT	WBR	NBL	NBT	NBR	SBL	SBT	SBR
Lane Configurations		↕			↕		↕	↕		↕	↕	
Traffic Vol, veh/h	7	4	0	8	0	6	1	632	8	7	670	19
Future Vol, veh/h	7	4	0	8	0	6	1	632	8	7	670	19
Conflicting Peds, #/hr	0	0	0	0	0	0	0	0	0	0	0	0
Sign Control	Stop	Stop	Stop	Stop	Stop	Stop	Free	Free	Free	Free	Free	Free
RT Channelized	-	-	None	-	-	None	-	-	None	-	-	None
Storage Length	-	-	-	-	-	-	50	-	-	50	-	-
Veh in Median Storage, #	-	1	-	-	1	-	-	0	-	-	0	-
Grade, %	-	0	-	-	0	-	-	0	-	-	0	-
Peak Hour Factor	92	92	92	92	92	92	92	92	92	92	92	92
Heavy Vehicles, %	2	2	2	2	2	2	2	2	2	2	2	2
Mvmt Flow	8	4	0	9	0	7	1	687	9	8	728	21

Major/Minor	Minor2		Minor1		Major1		Major2					
Conflicting Flow All	1101	1453	375	1076	1459	348	749	0	0	696	0	0
Stage 1	755	755	-	694	694	-	-	-	-	-	-	-
Stage 2	346	698	-	382	765	-	-	-	-	-	-	-
Critical Hdwy	7.54	6.54	6.94	7.54	6.54	6.94	4.14	-	-	4.14	-	-
Critical Hdwy Stg 1	6.54	5.54	-	6.54	5.54	-	-	-	-	-	-	-
Critical Hdwy Stg 2	6.54	5.54	-	6.54	5.54	-	-	-	-	-	-	-
Follow-up Hdwy	3.52	4.02	3.32	3.52	4.02	3.32	2.22	-	-	2.22	-	-
Pot Cap-1 Maneuver	166	129	623	174	128	648	856	-	-	896	-	-
Stage 1	367	415	-	399	442	-	-	-	-	-	-	-
Stage 2	643	440	-	612	410	-	-	-	-	-	-	-
Platoon blocked, %								-	-	-	-	-
Mov Cap-1 Maneuver	163	128	623	170	127	648	856	-	-	896	-	-
Mov Cap-2 Maneuver	278	251	-	291	251	-	-	-	-	-	-	-
Stage 1	367	411	-	399	442	-	-	-	-	-	-	-
Stage 2	636	440	-	600	406	-	-	-	-	-	-	-

Approach	EB		WB		NB		SB	
HCM Control Delay, s	19.1		14.8		0		0.1	
HCM LOS	C		B					

Minor Lane/Major Mvmt	NBL	NBT	NBR	EBLn1	WBLn1	SBL	SBT	SBR
Capacity (veh/h)	856	-	-	268	381	896	-	-
HCM Lane V/C Ratio	0.001	-	-	0.045	0.04	0.008	-	-
HCM Control Delay (s)	9.2	-	-	19.1	14.8	9.1	-	-
HCM Lane LOS	A	-	-	C	B	A	-	-
HCM 95th %tile Q(veh)	0	-	-	0.1	0.1	0	-	-

Intersection						
Int Delay, s/veh	2.2					
Movement	WBL	WBR	NBT	NBR	SBL	SBT
Lane Configurations	Y		↑↑		Y	↑↑
Traffic Vol, veh/h	58	23	621	96	53	611
Future Vol, veh/h	58	23	621	96	53	611
Conflicting Peds, #/hr	0	0	0	0	0	0
Sign Control	Stop	Stop	Free	Free	Free	Free
RT Channelized	-	None	-	None	-	None
Storage Length	0	-	-	-	140	-
Veh in Median Storage, #	0	-	0	-	-	0
Grade, %	0	-	0	-	-	0
Peak Hour Factor	91	91	91	91	91	91
Heavy Vehicles, %	2	2	2	2	2	2
Mvmt Flow	64	25	682	105	58	671

Major/Minor	Minor1	Major1	Major2		
Conflicting Flow All	1187	394	0	0	787
Stage 1	735	-	-	-	-
Stage 2	452	-	-	-	-
Critical Hdwy	6.84	6.94	-	-	4.14
Critical Hdwy Stg 1	5.84	-	-	-	-
Critical Hdwy Stg 2	5.84	-	-	-	-
Follow-up Hdwy	3.52	3.32	-	-	2.22
Pot Cap-1 Maneuver	181	605	-	-	828
Stage 1	435	-	-	-	-
Stage 2	608	-	-	-	-
Platoon blocked, %					
Mov Cap-1 Maneuver	168	605	-	-	828
Mov Cap-2 Maneuver	168	-	-	-	-
Stage 1	435	-	-	-	-
Stage 2	565	-	-	-	-

Approach	WB	NB	SB
HCM Control Delay, s	34	0	0.8
HCM LOS	D		

Minor Lane/Major Mvmt	NBT	NBRWBLn1	SBL	SBT
Capacity (veh/h)	-	-	211	828
HCM Lane V/C Ratio	-	-	0.422	0.07
HCM Control Delay (s)	-	-	34	9.7
HCM Lane LOS	-	-	D	A
HCM 95th %tile Q(veh)	-	-	1.9	0.2

Heritage at Dalia Ranch
4: Imperial Ave & Neckel Rd

Opening Year 2028
Timing Plan: PM PEAK



Movement	EBL	EBT	EBR	WBL	WBT	WBR	NBL	NBT	NBR	SBL	SBT	SBR
Lane Configurations		↕			↕		↕	↕		↕	↕	
Traffic Volume (veh/h)	13	28	4	141	21	68	12	659	180	61	568	30
Future Volume (veh/h)	13	28	4	141	21	68	12	659	180	61	568	30
Initial Q (Qb), veh	0	0	0	0	0	0	0	0	0	0	0	0
Ped-Bike Adj(A_pbT)	1.00		1.00	1.00		1.00	1.00		1.00	1.00		1.00
Parking Bus, Adj	1.00	1.00	1.00	1.00	1.00	1.00	1.00	1.00	1.00	1.00	1.00	1.00
Work Zone On Approach		No			No			No			No	
Adj Sat Flow, veh/h/ln	1870	1870	1870	1870	1870	1870	1870	1870	1870	1870	1870	1870
Adj Flow Rate, veh/h	14	30	4	153	23	74	13	716	196	66	617	33
Peak Hour Factor	0.92	0.92	0.92	0.92	0.92	0.92	0.92	0.92	0.92	0.92	0.92	0.92
Percent Heavy Veh, %	2	2	2	2	2	2	2	2	2	2	2	2
Cap, veh/h	25	55	7	199	30	96	29	886	243	105	1249	67
Arrive On Green	0.05	0.05	0.05	0.19	0.19	0.19	0.02	0.32	0.32	0.06	0.36	0.36
Sat Flow, veh/h	530	1135	151	1056	159	511	1781	2757	755	1781	3431	183
Grp Volume(v), veh/h	48	0	0	250	0	0	13	461	451	66	319	331
Grp Sat Flow(s),veh/h/ln	1817	0	0	1726	0	0	1781	1777	1735	1781	1777	1837
Q Serve(g_s), s	1.3	0.0	0.0	7.2	0.0	0.0	0.4	12.4	12.4	1.9	7.3	7.3
Cycle Q Clear(g_c), s	1.3	0.0	0.0	7.2	0.0	0.0	0.4	12.4	12.4	1.9	7.3	7.3
Prop In Lane	0.29		0.08	0.61		0.30	1.00		0.44	1.00		0.10
Lane Grp Cap(c), veh/h	87	0	0	325	0	0	29	571	558	105	647	669
V/C Ratio(X)	0.55	0.00	0.00	0.77	0.00	0.00	0.44	0.81	0.81	0.63	0.49	0.49
Avail Cap(c_a), veh/h	626	0	0	595	0	0	171	647	631	171	647	669
HCM Platoon Ratio	1.00	1.00	1.00	1.00	1.00	1.00	1.00	1.00	1.00	1.00	1.00	1.00
Upstream Filter(l)	1.00	0.00	0.00	1.00	0.00	0.00	1.00	1.00	1.00	1.00	1.00	1.00
Uniform Delay (d), s/veh	24.3	0.0	0.0	20.1	0.0	0.0	25.4	16.2	16.2	24.0	12.9	12.9
Incr Delay (d2), s/veh	5.3	0.0	0.0	3.8	0.0	0.0	10.2	6.8	6.9	6.0	0.6	0.6
Initial Q Delay(d3),s/veh	0.0	0.0	0.0	0.0	0.0	0.0	0.0	0.0	0.0	0.0	0.0	0.0
%ile BackOfQ(50%),veh/ln	0.7	0.0	0.0	2.9	0.0	0.0	0.2	5.4	5.3	0.9	2.6	2.7
Unsig. Movement Delay, s/veh												
LnGrp Delay(d),s/veh	29.6	0.0	0.0	23.9	0.0	0.0	35.6	23.0	23.2	30.0	13.5	13.4
LnGrp LOS	C	A	A	C	A	A	D	C	C	C	B	B
Approach Vol, veh/h		48			250			925			716	
Approach Delay, s/veh		29.6			23.9			23.3			15.0	
Approach LOS		C			C			C			B	
Timer - Assigned Phs	1	2		4	5	6		8				
Phs Duration (G+Y+Rc), s	8.1	21.8		7.5	5.9	24.0		14.8				
Change Period (Y+Rc), s	5.0	5.0		5.0	5.0	5.0		5.0				
Max Green Setting (Gmax), s	5.0	19.0		18.0	5.0	19.0		18.0				
Max Q Clear Time (g_c+I1), s	3.9	14.4		3.3	2.4	9.3		9.2				
Green Ext Time (p_c), s	0.0	2.3		0.1	0.0	2.8		0.9				
Intersection Summary												
HCM 6th Ctrl Delay				20.4								
HCM 6th LOS				C								

Intersection												
Int Delay, s/veh	7.7											
Movement	EBL	EBT	EBR	WBL	WBT	WBR	NBL	NBT	NBR	SBL	SBT	SBR
Lane Configurations		↕			↕			↕			↕	
Traffic Vol, veh/h	2	41	9	24	47	1	6	7	11	0	6	8
Future Vol, veh/h	2	41	9	24	47	1	6	7	11	0	6	8
Conflicting Peds, #/hr	0	0	0	0	0	0	0	0	0	0	0	0
Sign Control	Stop	Stop	Stop	Stop	Stop	Stop	Free	Free	Free	Free	Free	Free
RT Channelized	-	-	None	-	-	None	-	-	None	-	-	None
Storage Length	-	-	-	-	-	-	-	-	-	-	-	-
Veh in Median Storage, #	-	0	-	-	0	-	-	0	-	-	0	-
Grade, %	-	0	-	-	0	-	-	0	-	-	0	-
Peak Hour Factor	79	79	79	79	79	79	79	79	79	79	79	79
Heavy Vehicles, %	2	2	2	2	2	2	2	2	2	2	2	2
Mvmt Flow	3	52	11	30	59	1	8	9	14	0	8	10

Major/Minor	Minor2		Minor1		Major1			Major2				
Conflicting Flow All	75	52	13	77	50	16	18	0	0	23	0	0
Stage 1	13	13	-	32	32	-	-	-	-	-	-	-
Stage 2	62	39	-	45	18	-	-	-	-	-	-	-
Critical Hdwy	7.12	6.52	6.22	7.12	6.52	6.22	4.12	-	-	4.12	-	-
Critical Hdwy Stg 1	6.12	5.52	-	6.12	5.52	-	-	-	-	-	-	-
Critical Hdwy Stg 2	6.12	5.52	-	6.12	5.52	-	-	-	-	-	-	-
Follow-up Hdwy	3.518	4.018	3.318	3.518	4.018	3.318	2.218	-	-	2.218	-	-
Pot Cap-1 Maneuver	915	839	1067	912	841	1063	1599	-	-	1592	-	-
Stage 1	1007	885	-	984	868	-	-	-	-	-	-	-
Stage 2	949	862	-	969	880	-	-	-	-	-	-	-
Platoon blocked, %								-	-	-	-	-
Mov Cap-1 Maneuver	861	835	1067	856	837	1063	1599	-	-	1592	-	-
Mov Cap-2 Maneuver	861	835	-	856	837	-	-	-	-	-	-	-
Stage 1	1002	885	-	979	864	-	-	-	-	-	-	-
Stage 2	878	858	-	902	880	-	-	-	-	-	-	-

Approach	EB		WB		NB		SB	
HCM Control Delay, s	9.5		9.8		1.8		0	
HCM LOS	A		A					

Minor Lane/Major Mvmt	NBL	NBT	NBR	EBLn1	WBLn1	SBL	SBT	SBR
Capacity (veh/h)	1599	-	-	869	846	1592	-	-
HCM Lane V/C Ratio	0.005	-	-	0.076	0.108	-	-	-
HCM Control Delay (s)	7.3	0	-	9.5	9.8	0	-	-
HCM Lane LOS	A	A	-	A	A	A	-	-
HCM 95th %tile Q(veh)	0	-	-	0.2	0.4	0	-	-

Heritage at Dalia Ranch
6: Imperial Ave & Worthington Rd/Barioni Blvd

Opening Year 2028
Timing Plan: PM PEAK

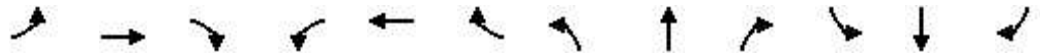

Movement	EBL	EBT	EBR	WBL	WBT	WBR	NBL	NBT	NBR	SBL	SBT	SBR
Lane Configurations		↖	↗		↖	↗	↖	↕		↖	↕	
Traffic Volume (veh/h)	78	79	112	58	120	55	120	843	15	29	711	82
Future Volume (veh/h)	78	79	112	58	120	55	120	843	15	29	711	82
Initial Q (Qb), veh	0	0	0	0	0	0	0	0	0	0	0	0
Ped-Bike Adj(A_pbT)	1.00		1.00	1.00		1.00	1.00		1.00	1.00		1.00
Parking Bus, Adj	1.00	1.00	1.00	1.00	1.00	1.00	1.00	1.00	1.00	1.00	1.00	1.00
Work Zone On Approach		No			No			No			No	
Adj Sat Flow, veh/h/ln	1870	1870	1870	1870	1870	1870	1870	1870	1870	1870	1870	1870
Adj Flow Rate, veh/h	86	87	123	64	132	60	132	926	16	32	781	90
Peak Hour Factor	0.91	0.91	0.91	0.91	0.91	0.91	0.91	0.91	0.91	0.91	0.91	0.91
Percent Heavy Veh, %	2	2	2	2	2	2	2	2	2	2	2	2
Cap, veh/h	126	128	221	89	183	234	168	1228	21	61	912	105
Arrive On Green	0.14	0.14	0.14	0.15	0.15	0.15	0.09	0.34	0.34	0.03	0.28	0.28
Sat Flow, veh/h	907	918	1585	601	1239	1585	1781	3574	62	1781	3211	370
Grp Volume(v), veh/h	173	0	123	196	0	60	132	460	482	32	432	439
Grp Sat Flow(s),veh/h/ln	1825	0	1585	1840	0	1585	1781	1777	1859	1781	1777	1804
Q Serve(g_s), s	5.4	0.0	4.3	6.1	0.0	2.0	4.3	13.7	13.7	1.1	13.7	13.7
Cycle Q Clear(g_c), s	5.4	0.0	4.3	6.1	0.0	2.0	4.3	13.7	13.7	1.1	13.7	13.7
Prop In Lane	0.50		1.00	0.33		1.00	1.00		0.03	1.00		0.21
Lane Grp Cap(c), veh/h	254	0	221	272	0	234	168	611	639	61	505	512
V/C Ratio(X)	0.68	0.00	0.56	0.72	0.00	0.26	0.79	0.75	0.75	0.52	0.86	0.86
Avail Cap(c_a), veh/h	550	0	478	555	0	478	179	611	639	149	536	544
HCM Platoon Ratio	1.00	1.00	1.00	1.00	1.00	1.00	1.00	1.00	1.00	1.00	1.00	1.00
Upstream Filter(I)	1.00	0.00	1.00	1.00	0.00	1.00	1.00	1.00	1.00	1.00	1.00	1.00
Uniform Delay (d), s/veh	24.4	0.0	24.0	24.3	0.0	22.5	26.4	17.4	17.4	28.3	20.2	20.2
Incr Delay (d2), s/veh	3.2	0.0	2.2	3.6	0.0	0.6	19.4	5.3	5.1	6.7	12.4	12.3
Initial Q Delay(d3),s/veh	0.0	0.0	0.0	0.0	0.0	0.0	0.0	0.0	0.0	0.0	0.0	0.0
%ile BackOfQ(50%),veh/ln	2.4	0.0	1.6	2.7	0.0	0.7	2.6	5.9	6.1	0.5	6.9	7.0
Unsig. Movement Delay, s/veh												
LnGrp Delay(d),s/veh	27.6	0.0	26.2	27.9	0.0	23.1	45.9	22.6	22.4	35.0	32.6	32.5
LnGrp LOS	C	A	C	C	A	C	D	C	C	D	C	C
Approach Vol, veh/h		296			256			1074			903	
Approach Delay, s/veh		27.0			26.8			25.4			32.7	
Approach LOS		C			C			C			C	
Timer - Assigned Phs	1	2		4	5	6		8				
Phs Duration (G+Y+Rc), s	7.1	25.5		13.3	10.6	21.9		13.8				
Change Period (Y+Rc), s	5.0	5.0		5.0	5.0	5.0		5.0				
Max Green Setting (Gmax), s	5.0	19.0		18.0	6.0	18.0		18.0				
Max Q Clear Time (g_c+I1), s	3.1	15.7		7.4	6.3	15.7		8.1				
Green Ext Time (p_c), s	0.0	1.8		1.0	0.0	1.2		0.9				
Intersection Summary												
HCM 6th Ctrl Delay			28.3									
HCM 6th LOS			C									

Intersection												
Intersection Delay, s/veh	11.7											
Intersection LOS	B											

Movement	EBL	EBT	EBR	WBL	WBT	WBR	NBL	NBT	NBR	SBL	SBT	SBR
Lane Configurations		↔	↔		↔	↔		↔			↔	
Traffic Vol, veh/h	28	227	35	29	245	36	1	0	0	40	6	25
Future Vol, veh/h	28	227	35	29	245	36	1	0	0	40	6	25
Peak Hour Factor	0.80	0.80	0.80	0.80	0.80	0.80	0.80	0.80	0.80	0.80	0.80	0.80
Heavy Vehicles, %	2	2	2	2	2	2	2	2	2	2	2	2
Mvmt Flow	35	284	44	36	306	45	1	0	0	50	8	31
Number of Lanes	0	1	1	0	1	1	0	1	0	0	1	0

Approach	EB	WB	NB	SB
Opposing Approach	WB	EB	SB	NB
Opposing Lanes	2	2	1	1
Conflicting Approach Left	SB	NB	EB	WB
Conflicting Lanes Left	1	1	2	2
Conflicting Approach Right	NB	SB	WB	EB
Conflicting Lanes Right	1	1	2	2
HCM Control Delay	11.7	12.2	9.1	9.5
HCM LOS	B	B	A	A

Lane	NBLn1	EBLn1	EBLn2	WBLn1	WBLn2	SBLn1
Vol Left, %	100%	11%	0%	11%	0%	56%
Vol Thru, %	0%	89%	0%	89%	0%	8%
Vol Right, %	0%	0%	100%	0%	100%	35%
Sign Control	Stop	Stop	Stop	Stop	Stop	Stop
Traffic Vol by Lane	1	255	35	274	36	71
LT Vol	1	28	0	29	0	40
Through Vol	0	227	0	245	0	6
RT Vol	0	0	35	0	36	25
Lane Flow Rate	1	319	44	342	45	89
Geometry Grp	2	7	7	7	7	2
Degree of Util (X)	0.002	0.458	0.054	0.49	0.055	0.137
Departure Headway (Hd)	6.024	5.171	4.411	5.148	4.391	5.54
Convergence, Y/N	Yes	Yes	Yes	Yes	Yes	Yes
Cap	589	695	808	699	812	643
Service Time	4.115	2.919	2.159	2.895	2.138	3.605
HCM Lane V/C Ratio	0.002	0.459	0.054	0.489	0.055	0.138
HCM Control Delay	9.1	12.3	7.4	12.8	7.4	9.5
HCM Lane LOS	A	B	A	B	A	A
HCM 95th-tile Q	0	2.4	0.2	2.7	0.2	0.5

Heritage at Dalia Ranch
8: Imperial Ave & Aten Rd

Opening Year 2028
Timing Plan: PM PEAK



Movement	EBL	EBT	EBR	WBL	WBT	WBR	NBL	NBT	NBR	SBL	SBT	SBR
Lane Configurations												
Traffic Volume (veh/h)	229	295	73	191	309	131	84	814	160	120	636	239
Future Volume (veh/h)	229	295	73	191	309	131	84	814	160	120	636	239
Initial Q (Qb), veh	0	0	0	0	0	0	0	0	0	0	0	0
Ped-Bike Adj(A_pbT)	1.00		1.00	1.00		1.00	1.00		1.00	1.00		1.00
Parking Bus, Adj	1.00	1.00	1.00	1.00	1.00	1.00	1.00	1.00	1.00	1.00	1.00	1.00
Work Zone On Approach		No			No			No			No	
Adj Sat Flow, veh/h/ln	1870	1870	1870	1870	1870	1870	1870	1870	1870	1870	1870	1870
Adj Flow Rate, veh/h	244	314	78	203	329	139	89	866	170	128	677	254
Peak Hour Factor	0.94	0.94	0.94	0.94	0.94	0.94	0.94	0.94	0.94	0.94	0.94	0.94
Percent Heavy Veh, %	2	2	2	2	2	2	2	2	2	2	2	2
Cap, veh/h	287	581	142	246	448	186	114	970	432	162	1065	475
Arrive On Green	0.16	0.21	0.21	0.14	0.18	0.18	0.06	0.27	0.27	0.09	0.30	0.30
Sat Flow, veh/h	1781	2830	693	1781	2449	1015	1781	3554	1585	1781	3554	1585
Grp Volume(v), veh/h	244	195	197	203	237	231	89	866	170	128	677	254
Grp Sat Flow(s),veh/h/ln	1781	1777	1746	1781	1777	1688	1781	1777	1585	1781	1777	1585
Q Serve(g_s), s	9.1	6.7	6.9	7.6	8.6	8.9	3.4	16.0	6.0	4.8	11.3	9.1
Cycle Q Clear(g_c), s	9.1	6.7	6.9	7.6	8.6	8.9	3.4	16.0	6.0	4.8	11.3	9.1
Prop In Lane	1.00		0.40	1.00		0.60	1.00		1.00	1.00		1.00
Lane Grp Cap(c), veh/h	287	365	358	246	325	308	114	970	432	162	1065	475
V/C Ratio(X)	0.85	0.54	0.55	0.82	0.73	0.75	0.78	0.89	0.39	0.79	0.64	0.53
Avail Cap(c_a), veh/h	287	468	460	287	468	444	156	988	441	182	1065	475
HCM Platoon Ratio	1.00	1.00	1.00	1.00	1.00	1.00	1.00	1.00	1.00	1.00	1.00	1.00
Upstream Filter(l)	1.00	1.00	1.00	1.00	1.00	1.00	1.00	1.00	1.00	1.00	1.00	1.00
Uniform Delay (d), s/veh	27.9	24.2	24.3	28.6	26.3	26.4	31.5	23.9	20.2	30.4	20.7	20.0
Incr Delay (d2), s/veh	21.0	1.2	1.3	15.5	3.3	4.2	15.6	10.3	0.6	18.6	1.3	1.2
Initial Q Delay(d3),s/veh	0.0	0.0	0.0	0.0	0.0	0.0	0.0	0.0	0.0	0.0	0.0	0.0
%ile BackOfQ(50%),veh/ln	5.4	2.8	2.8	4.1	3.8	3.7	1.9	7.6	2.1	2.8	4.5	3.3
Unsig. Movement Delay, s/veh												
LnGrp Delay(d),s/veh	48.9	25.5	25.6	44.2	29.6	30.6	47.1	34.2	20.8	49.0	22.0	21.1
LnGrp LOS	D	C	C	D	C	C	D	C	C	D	C	C
Approach Vol, veh/h		636			671			1125			1059	
Approach Delay, s/veh		34.5			34.4			33.2			25.0	
Approach LOS		C			C			C			C	
Timer - Assigned Phs	1	2	3	4	5	6	7	8				
Phs Duration (G+Y+Rc), s	11.2	23.6	14.5	19.0	9.4	25.5	16.0	17.5				
Change Period (Y+Rc), s	5.0	5.0	5.0	5.0	5.0	5.0	5.0	5.0				
Max Green Setting (Gmax), s	19.0	11.0	18.0	6.0	20.0	11.0	18.0					
Max Q Clear Time (g_c+1/3), s	18.0	9.6	8.9	5.4	13.3	11.1	10.9					
Green Ext Time (p_c), s	0.0	0.6	0.1	1.5	0.0	3.0	0.0	1.6				
Intersection Summary												
HCM 6th Ctrl Delay											31.2	
HCM 6th LOS											C	

Heritage at Dalia Ranch
1: SR-86 & Keystone Rd

Opening Year 2028 + P1-4 Proj
Timing Plan: AM PEAK

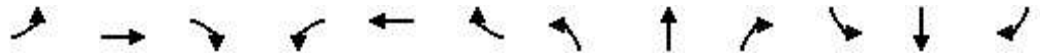

Movement	EBL	EBT	EBR	WBL	WBT	WBR	NBL	NBT	NBR	SBL	SBT	SBR
Lane Configurations		↕			↕		↗	↕	↗	↗	↕	↗
Traffic Volume (veh/h)	35	35	12	20	25	45	20	601	53	48	620	40
Future Volume (veh/h)	35	35	12	20	25	45	20	601	53	48	620	40
Initial Q (Qb), veh	0	0	0	0	0	0	0	0	0	0	0	0
Ped-Bike Adj(A_pbT)	1.00		1.00	1.00		1.00	1.00		1.00	1.00		1.00
Parking Bus, Adj	1.00	1.00	1.00	1.00	1.00	1.00	1.00	1.00	1.00	1.00	1.00	1.00
Work Zone On Approach		No			No			No			No	
Adj Sat Flow, veh/h/ln	1870	1870	1870	1870	1870	1870	1870	1870	1870	1870	1870	1870
Adj Flow Rate, veh/h	39	39	13	22	28	50	22	668	59	53	689	44
Peak Hour Factor	0.90	0.90	0.90	0.90	0.90	0.90	0.90	0.90	0.90	0.90	0.90	0.90
Percent Heavy Veh, %	2	2	2	2	2	2	2	2	2	2	2	2
Cap, veh/h	241	108	31	175	72	107	50	1184	528	105	1295	578
Arrive On Green	0.13	0.13	0.13	0.13	0.13	0.13	0.03	0.33	0.33	0.06	0.36	0.36
Sat Flow, veh/h	595	834	238	271	554	825	1781	3554	1585	1781	3554	1585
Grp Volume(v), veh/h	91	0	0	100	0	0	22	668	59	53	689	44
Grp Sat Flow(s),veh/h/ln	1667	0	0	1651	0	0	1781	1777	1585	1781	1777	1585
Q Serve(g_s), s	0.0	0.0	0.0	0.2	0.0	0.0	0.4	4.8	0.8	0.9	4.8	0.6
Cycle Q Clear(g_c), s	1.4	0.0	0.0	1.7	0.0	0.0	0.4	4.8	0.8	0.9	4.8	0.6
Prop In Lane	0.43		0.14	0.22		0.50	1.00		1.00	1.00		1.00
Lane Grp Cap(c), veh/h	380	0	0	353	0	0	50	1184	528	105	1295	578
V/C Ratio(X)	0.24	0.00	0.00	0.28	0.00	0.00	0.44	0.56	0.11	0.50	0.53	0.08
Avail Cap(c_a), veh/h	1071	0	0	1062	0	0	284	2040	910	284	2040	910
HCM Platoon Ratio	1.00	1.00	1.00	1.00	1.00	1.00	1.00	1.00	1.00	1.00	1.00	1.00
Upstream Filter(l)	1.00	0.00	0.00	1.00	0.00	0.00	1.00	1.00	1.00	1.00	1.00	1.00
Uniform Delay (d), s/veh	12.5	0.0	0.0	12.6	0.0	0.0	15.0	8.6	7.2	14.3	7.9	6.5
Incr Delay (d2), s/veh	0.3	0.0	0.0	0.4	0.0	0.0	6.1	0.4	0.1	3.7	0.3	0.1
Initial Q Delay(d3),s/veh	0.0	0.0	0.0	0.0	0.0	0.0	0.0	0.0	0.0	0.0	0.0	0.0
%ile BackOfQ(50%),veh/ln	0.5	0.0	0.0	0.5	0.0	0.0	0.2	1.3	0.2	0.4	1.2	0.1
Unsig. Movement Delay, s/veh												
LnGrp Delay(d),s/veh	12.8	0.0	0.0	13.0	0.0	0.0	21.1	9.0	7.3	18.0	8.2	6.6
LnGrp LOS	B	A	A	B	A	A	C	A	A	B	A	A
Approach Vol, veh/h		91			100			749			786	
Approach Delay, s/veh		12.8			13.0			9.2			8.8	
Approach LOS		B			B			A			A	
Timer - Assigned Phs	1	2		4	5	6		8				
Phs Duration (G+Y+Rc), s	6.8	15.4		9.1	5.9	16.4		9.1				
Change Period (Y+Rc), s	5.0	5.0		5.0	5.0	5.0		5.0				
Max Green Setting (Gmax), s	5.0	18.0		18.0	5.0	18.0		18.0				
Max Q Clear Time (g_c+I1), s	2.9	6.8		3.4	2.4	6.8		3.7				
Green Ext Time (p_c), s	0.0	3.6		0.3	0.0	3.7		0.4				
Intersection Summary												
HCM 6th Ctrl Delay				9.4								
HCM 6th LOS				A								

Intersection												
Int Delay, s/veh	0.4											
Movement	EBL	EBT	EBR	WBL	WBT	WBR	NBL	NBT	NBR	SBL	SBT	SBR
Lane Configurations		↕			↕		↕	↕		↕	↕	
Traffic Vol, veh/h	21	3	2	1	2	6	0	672	1	1	625	8
Future Vol, veh/h	21	3	2	1	2	6	0	672	1	1	625	8
Conflicting Peds, #/hr	0	0	0	0	0	0	0	0	0	0	0	0
Sign Control	Stop	Stop	Stop	Stop	Stop	Stop	Free	Free	Free	Free	Free	Free
RT Channelized	-	-	None	-	-	None	-	-	None	-	-	None
Storage Length	-	-	-	-	-	-	50	-	-	50	-	-
Veh in Median Storage, #	-	1	-	-	1	-	-	0	-	-	0	-
Grade, %	-	0	-	-	0	-	-	0	-	-	0	-
Peak Hour Factor	94	94	94	94	94	94	94	94	94	94	94	94
Heavy Vehicles, %	2	2	2	2	2	2	2	2	2	2	2	2
Mvmt Flow	22	3	2	1	2	6	0	715	1	1	665	9

Major/Minor	Minor2		Minor1		Major1			Major2				
Conflicting Flow All	1031	1388	337	1052	1392	358	674	0	0	716	0	0
Stage 1	672	672	-	716	716	-	-	-	-	-	-	-
Stage 2	359	716	-	336	676	-	-	-	-	-	-	-
Critical Hdwy	7.54	6.54	6.94	7.54	6.54	6.94	4.14	-	-	4.14	-	-
Critical Hdwy Stg 1	6.54	5.54	-	6.54	5.54	-	-	-	-	-	-	-
Critical Hdwy Stg 2	6.54	5.54	-	6.54	5.54	-	-	-	-	-	-	-
Follow-up Hdwy	3.52	4.02	3.32	3.52	4.02	3.32	2.22	-	-	2.22	-	-
Pot Cap-1 Maneuver	187	142	659	181	141	638	913	-	-	880	-	-
Stage 1	412	453	-	387	432	-	-	-	-	-	-	-
Stage 2	632	432	-	652	451	-	-	-	-	-	-	-
Platoon blocked, %								-	-	-	-	-
Mov Cap-1 Maneuver	184	142	659	179	141	638	913	-	-	880	-	-
Mov Cap-2 Maneuver	305	266	-	295	266	-	-	-	-	-	-	-
Stage 1	412	453	-	387	432	-	-	-	-	-	-	-
Stage 2	623	432	-	645	451	-	-	-	-	-	-	-

Approach	EB		WB		NB			SB		
HCM Control Delay, s	17.6		13.3		0			0		
HCM LOS	C		B							

Minor Lane/Major Mvmt	NBL	NBT	NBR	EBLn1	WBLn1	SBL	SBT	SBR
Capacity (veh/h)	913	-	-	313	443	880	-	-
HCM Lane V/C Ratio	-	-	-	0.088	0.022	0.001	-	-
HCM Control Delay (s)	0	-	-	17.6	13.3	9.1	-	-
HCM Lane LOS	A	-	-	C	B	A	-	-
HCM 95th %tile Q(veh)	0	-	-	0.3	0.1	0	-	-

Heritage at Dalia Ranch
3: Imperial Ave & Ralph Rd

Opening Year 2028 + P1-4 Proj
Timing Plan: AM PEAK

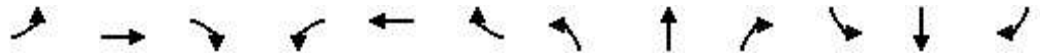

Movement	EBL	EBT	EBR	WBL	WBT	WBR	NBL	NBT	NBR	SBL	SBT	SBR
Lane Configurations												
Traffic Volume (veh/h)	82	11	106	127	17	45	134	546	63	27	562	39
Future Volume (veh/h)	82	11	106	127	17	45	134	546	63	27	562	39
Initial Q (Qb), veh	0	0	0	0	0	0	0	0	0	0	0	0
Ped-Bike Adj(A_pbT)	1.00		1.00	1.00		1.00	1.00		1.00	1.00		1.00
Parking Bus, Adj	1.00	1.00	1.00	1.00	1.00	1.00	1.00	1.00	1.00	1.00	1.00	1.00
Work Zone On Approach		No			No			No			No	
Adj Sat Flow, veh/h/ln	1870	1870	1870	1870	1870	1870	1870	1870	1870	1870	1870	1870
Adj Flow Rate, veh/h	89	12	115	140	18	49	146	600	69	30	618	42
Peak Hour Factor	0.92	0.92	0.92	0.91	0.92	0.91	0.92	0.91	0.91	0.91	0.91	0.92
Percent Heavy Veh, %	2	2	2	2	2	2	2	2	2	2	2	2
Cap, veh/h	178	19	179	211	63	171	186	1035	119	61	896	399
Arrive On Green	0.10	0.12	0.12	0.12	0.14	0.14	0.10	0.32	0.32	0.03	0.25	0.25
Sat Flow, veh/h	1781	152	1456	1781	444	1209	1781	3212	369	1781	3554	1585
Grp Volume(v), veh/h	89	0	127	140	0	67	146	331	338	30	618	42
Grp Sat Flow(s),veh/h/ln	1781	0	1608	1781	0	1653	1781	1777	1804	1781	1777	1585
Q Serve(g_s), s	2.4	0.0	3.7	3.7	0.0	1.8	4.0	7.7	7.8	0.8	7.8	1.0
Cycle Q Clear(g_c), s	2.4	0.0	3.7	3.7	0.0	1.8	4.0	7.7	7.8	0.8	7.8	1.0
Prop In Lane	1.00		0.91	1.00		0.73	1.00		0.20	1.00		1.00
Lane Grp Cap(c), veh/h	178	0	197	211	0	234	186	572	581	61	896	399
V/C Ratio(X)	0.50	0.00	0.64	0.66	0.00	0.29	0.79	0.58	0.58	0.49	0.69	0.11
Avail Cap(c_a), veh/h	645	0	582	645	0	598	215	679	689	179	1287	574
HCM Platoon Ratio	1.00	1.00	1.00	1.00	1.00	1.00	1.00	1.00	1.00	1.00	1.00	1.00
Upstream Filter(l)	1.00	0.00	1.00	1.00	0.00	1.00	1.00	1.00	1.00	1.00	1.00	1.00
Uniform Delay (d), s/veh	21.2	0.0	20.8	21.0	0.0	19.1	21.7	14.0	14.1	23.6	16.8	14.3
Incr Delay (d2), s/veh	2.2	0.0	3.5	3.5	0.0	0.7	15.3	0.9	0.9	6.1	1.0	0.1
Initial Q Delay(d3),s/veh	0.0	0.0	0.0	0.0	0.0	0.0	0.0	0.0	0.0	0.0	0.0	0.0
%ile BackOfQ(50%),veh/ln	1.0	0.0	1.5	1.6	0.0	0.7	2.3	2.8	2.8	0.4	2.9	0.3
Unsig. Movement Delay, s/veh												
LnGrp Delay(d),s/veh	23.4	0.0	24.2	24.5	0.0	19.8	37.0	15.0	15.0	29.7	17.8	14.4
LnGrp LOS	C	A	C	C	A	B	D	B	B	C	B	B
Approach Vol, veh/h		216			207			815			690	
Approach Delay, s/veh		23.9			22.9			18.9			18.1	
Approach LOS		C			C			B			B	
Timer - Assigned Phs	1	2	3	4	5	6	7	8				
Phs Duration (G+Y+Rc), s	6.7	21.0	10.9	11.1	10.2	17.5	10.0	12.0				
Change Period (Y+Rc), s	5.0	5.0	5.0	5.0	5.0	5.0	5.0	5.0				
Max Green Setting (Gmax), s	5.0	19.0	18.0	18.0	6.0	18.0	18.0	18.0				
Max Q Clear Time (g_c+I1), s	2.8	9.8	5.7	5.7	6.0	9.8	4.4	3.8				
Green Ext Time (p_c), s	0.0	2.8	0.3	0.5	0.0	2.7	0.2	0.2				
Intersection Summary												
HCM 6th Ctrl Delay			19.6									
HCM 6th LOS			B									

Heritage at Dalia Ranch
4: Imperial Ave & Neckel Rd

Opening Year 2028 + P1-4 Proj
Timing Plan: AM PEAK



Movement	EBL	EBT	EBR	WBL	WBT	WBR	NBL	NBT	NBR	SBL	SBT	SBR
Lane Configurations		↕			↕		↗	↕		↗	↕	
Traffic Volume (veh/h)	36	46	143	232	68	104	54	610	96	35	750	33
Future Volume (veh/h)	36	46	143	232	68	104	54	610	96	35	750	33
Initial Q (Qb), veh	0	0	0	0	0	0	0	0	0	0	0	0
Ped-Bike Adj(A_pbT)	1.00		1.00	1.00		1.00	1.00		1.00	1.00		1.00
Parking Bus, Adj	1.00	1.00	1.00	1.00	1.00	1.00	1.00	1.00	1.00	1.00	1.00	1.00
Work Zone On Approach		No			No			No			No	
Adj Sat Flow, veh/h/ln	1870	1870	1870	1870	1870	1870	1870	1870	1870	1870	1870	1870
Adj Flow Rate, veh/h	40	51	157	255	75	114	59	670	105	38	824	36
Peak Hour Factor	0.91	0.91	0.91	0.91	0.91	0.91	0.91	0.91	0.91	0.91	0.91	0.91
Percent Heavy Veh, %	2	2	2	2	2	2	2	2	2	2	2	2
Cap, veh/h	48	61	188	244	72	109	85	828	130	65	895	39
Arrive On Green	0.18	0.18	0.18	0.24	0.24	0.24	0.05	0.27	0.27	0.04	0.26	0.26
Sat Flow, veh/h	269	343	1055	999	294	447	1781	3079	482	1781	3468	152
Grp Volume(v), veh/h	248	0	0	444	0	0	59	386	389	38	422	438
Grp Sat Flow(s),veh/h/ln	1667	0	0	1740	0	0	1781	1777	1784	1781	1777	1843
Q Serve(g_s), s	10.6	0.0	0.0	18.0	0.0	0.0	2.4	15.0	15.0	1.5	17.0	17.0
Cycle Q Clear(g_c), s	10.6	0.0	0.0	18.0	0.0	0.0	2.4	15.0	15.0	1.5	17.0	17.0
Prop In Lane	0.16		0.63	0.57		0.26	1.00		0.27	1.00		0.08
Lane Grp Cap(c), veh/h	298	0	0	425	0	0	85	478	480	65	458	475
V/C Ratio(X)	0.83	0.00	0.00	1.04	0.00	0.00	0.70	0.81	0.81	0.58	0.92	0.92
Avail Cap(c_a), veh/h	407	0	0	425	0	0	121	478	480	121	458	475
HCM Platoon Ratio	1.00	1.00	1.00	1.00	1.00	1.00	1.00	1.00	1.00	1.00	1.00	1.00
Upstream Filter(l)	1.00	0.00	0.00	1.00	0.00	0.00	1.00	1.00	1.00	1.00	1.00	1.00
Uniform Delay (d), s/veh	29.2	0.0	0.0	27.8	0.0	0.0	34.5	25.2	25.2	34.9	26.6	26.6
Incr Delay (d2), s/veh	10.3	0.0	0.0	55.6	0.0	0.0	9.8	10.0	10.1	7.9	23.9	23.3
Initial Q Delay(d3),s/veh	0.0	0.0	0.0	0.0	0.0	0.0	0.0	0.0	0.0	0.0	0.0	0.0
%ile BackOfQ(50%),veh/ln	4.9	0.0	0.0	13.6	0.0	0.0	1.2	7.3	7.3	0.8	9.9	10.2
Unsig. Movement Delay, s/veh												
LnGrp Delay(d),s/veh	39.5	0.0	0.0	83.4	0.0	0.0	44.4	35.2	35.2	42.9	50.5	49.9
LnGrp LOS	D	A	A	F	A	A	D	D	D	D	D	D
Approach Vol, veh/h		248			444			834			898	
Approach Delay, s/veh		39.5			83.4			35.8			49.9	
Approach LOS		D			F			D			D	
Timer - Assigned Phs	1	2		4	5	6		8				
Phs Duration (G+Y+Rc), s	7.7	24.8		18.1	8.5	24.0		23.0				
Change Period (Y+Rc), s	5.0	5.0		5.0	5.0	5.0		5.0				
Max Green Setting (Gmax), s	5.0	19.0		18.0	5.0	19.0		18.0				
Max Q Clear Time (g_c+13), s	13.5	17.0		12.6	4.4	19.0		20.0				
Green Ext Time (p_c), s	0.0	1.0		0.7	0.0	0.0		0.0				
Intersection Summary												
HCM 6th Ctrl Delay				50.1								
HCM 6th LOS				D								

Intersection												
Int Delay, s/veh	11.9											
Movement	EBL	EBT	EBR	WBL	WBT	WBR	NBL	NBT	NBR	SBL	SBT	SBR
Lane Configurations		↕			↕			↕			↕	
Traffic Vol, veh/h	4	44	24	71	47	94	8	33	48	155	36	1
Future Vol, veh/h	4	44	24	71	47	94	8	33	48	155	36	1
Conflicting Peds, #/hr	0	0	0	0	0	0	0	0	0	0	0	0
Sign Control	Stop	Stop	Stop	Stop	Stop	Stop	Free	Free	Free	Free	Free	Free
RT Channelized	-	-	None	-	-	None	-	-	None	-	-	None
Storage Length	-	-	-	-	-	-	-	-	-	-	-	-
Veh in Median Storage, #	-	0	-	-	0	-	-	0	-	-	0	-
Grade, %	-	0	-	-	0	-	-	0	-	-	0	-
Peak Hour Factor	79	79	79	79	79	79	79	79	79	79	79	79
Heavy Vehicles, %	2	2	2	2	2	2	2	2	2	2	2	2
Mvmt Flow	5	56	30	90	59	119	10	42	61	196	46	1

Major/Minor	Minor2		Minor1		Major1		Major2					
Conflicting Flow All	621	562	47	575	532	73	47	0	0	103	0	0
Stage 1	439	439	-	93	93	-	-	-	-	-	-	-
Stage 2	182	123	-	482	439	-	-	-	-	-	-	-
Critical Hdwy	7.12	6.52	6.22	7.12	6.52	6.22	4.12	-	-	4.12	-	-
Critical Hdwy Stg 1	6.12	5.52	-	6.12	5.52	-	-	-	-	-	-	-
Critical Hdwy Stg 2	6.12	5.52	-	6.12	5.52	-	-	-	-	-	-	-
Follow-up Hdwy	3.518	4.018	3.318	3.518	4.018	3.318	2.218	-	-	2.218	-	-
Pot Cap-1 Maneuver	400	436	1022	429	453	989	1560	-	-	1489	-	-
Stage 1	597	578	-	914	818	-	-	-	-	-	-	-
Stage 2	820	794	-	565	578	-	-	-	-	-	-	-
Platoon blocked, %								-	-	-	-	-
Mov Cap-1 Maneuver	278	375	1022	330	389	989	1560	-	-	1489	-	-
Mov Cap-2 Maneuver	278	375	-	330	389	-	-	-	-	-	-	-
Stage 1	593	500	-	908	812	-	-	-	-	-	-	-
Stage 2	664	788	-	421	500	-	-	-	-	-	-	-

Approach	EB		WB		NB		SB	
HCM Control Delay, s	14.6		20.7		0.7		6.3	
HCM LOS	B		C					

Minor Lane/Major Mvmt	NBL	NBT	NBR	EBLn1WBLn1	SBL	SBT	SBR
Capacity (veh/h)	1560	-	-	464	492	1489	-
HCM Lane V/C Ratio	0.006	-	-	0.196	0.545	0.132	-
HCM Control Delay (s)	7.3	0	-	14.6	20.7	7.8	0
HCM Lane LOS	A	A	-	B	C	A	A
HCM 95th %tile Q(veh)	0	-	-	0.7	3.2	0.5	-

Heritage at Dalia Ranch
6: Imperial Ave & Worthington Rd/Barioni Blvd

Opening Year 2028 + P1-4 Proj
Timing Plan: AM PEAK

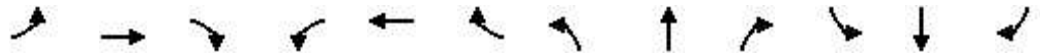

Movement	EBL	EBT	EBR	WBL	WBT	WBR	NBL	NBT	NBR	SBL	SBT	SBR
Lane Configurations		↕	↗		↖	↗	↖	↕	↗	↖	↕	↗
Traffic Volume (veh/h)	83	145	227	58	141	111	99	670	54	84	1022	84
Future Volume (veh/h)	83	145	227	58	141	111	99	670	54	84	1022	84
Initial Q (Qb), veh	0	0	0	0	0	0	0	0	0	0	0	0
Ped-Bike Adj(A_pbT)	1.00		1.00	1.00		1.00	1.00		1.00	1.00		1.00
Parking Bus, Adj	1.00	1.00	1.00	1.00	1.00	1.00	1.00	1.00	1.00	1.00	1.00	1.00
Work Zone On Approach		No			No			No			No	
Adj Sat Flow, veh/h/ln	1870	1870	1870	1870	1870	1870	1870	1870	1870	1870	1870	1870
Adj Flow Rate, veh/h	93	163	255	65	158	125	111	753	61	94	1148	94
Peak Hour Factor	0.89	0.89	0.89	0.89	0.89	0.89	0.89	0.89	0.89	0.89	0.89	0.89
Percent Heavy Veh, %	2	2	2	2	2	2	2	2	2	2	2	2
Cap, veh/h	127	222	300	82	199	241	130	1155	94	120	1136	93
Arrive On Green	0.19	0.19	0.19	0.15	0.15	0.15	0.07	0.35	0.35	0.07	0.34	0.34
Sat Flow, veh/h	667	1170	1585	537	1306	1585	1781	3329	270	1781	3326	272
Grp Volume(v), veh/h	256	0	255	223	0	125	111	402	412	94	613	629
Grp Sat Flow(s),veh/h/ln	1837	0	1585	1843	0	1585	1781	1777	1822	1781	1777	1821
Q Serve(g_s), s	10.8	0.0	12.7	9.6	0.0	6.0	5.1	15.6	15.7	4.3	28.0	28.0
Cycle Q Clear(g_c), s	10.8	0.0	12.7	9.6	0.0	6.0	5.1	15.6	15.7	4.3	28.0	28.0
Prop In Lane	0.36		1.00	0.29		1.00	1.00		0.15	1.00		0.15
Lane Grp Cap(c), veh/h	348	0	300	280	0	241	130	617	632	120	607	622
V/C Ratio(X)	0.74	0.00	0.85	0.80	0.00	0.52	0.85	0.65	0.65	0.78	1.01	1.01
Avail Cap(c_a), veh/h	403	0	348	405	0	348	130	617	632	152	607	622
HCM Platoon Ratio	1.00	1.00	1.00	1.00	1.00	1.00	1.00	1.00	1.00	1.00	1.00	1.00
Upstream Filter(l)	1.00	0.00	1.00	1.00	0.00	1.00	1.00	1.00	1.00	1.00	1.00	1.00
Uniform Delay (d), s/veh	31.3	0.0	32.1	33.5	0.0	32.0	37.6	22.6	22.6	37.6	27.0	27.0
Incr Delay (d2), s/veh	5.8	0.0	15.8	6.9	0.0	1.7	38.6	2.4	2.4	18.2	39.0	39.1
Initial Q Delay(d3),s/veh	0.0	0.0	0.0	0.0	0.0	0.0	0.0	0.0	0.0	0.0	0.0	0.0
%ile BackOfQ(50%),veh/ln	5.2	0.0	6.1	4.7	0.0	2.3	3.6	6.6	6.8	2.4	17.8	18.2
Unsig. Movement Delay, s/veh												
LnGrp Delay(d),s/veh	37.1	0.0	47.9	40.4	0.0	33.7	76.2	25.0	25.0	55.8	66.1	66.1
LnGrp LOS	D	A	D	D	A	C	E	C	C	E	F	F
Approach Vol, veh/h		511			348			925			1336	
Approach Delay, s/veh		42.5			38.0			31.1			65.4	
Approach LOS		D			D			C			E	
Timer - Assigned Phs	1	2		4	5	6		8				
Phs Duration (G+Y+Rc), s	10.5	33.5		20.5	11.0	33.0		17.5				
Change Period (Y+Rc), s	5.0	5.0		5.0	5.0	5.0		5.0				
Max Green Setting (Gmax), s	7.0	27.0		18.0	6.0	28.0		18.0				
Max Q Clear Time (g_c+I1), s	6.3	17.7		14.7	7.1	30.0		11.6				
Green Ext Time (p_c), s	0.0	3.5		0.8	0.0	0.0		0.9				
Intersection Summary												
HCM 6th Ctrl Delay			48.4									
HCM 6th LOS			D									

Intersection												
Intersection Delay, s/veh	34.2											
Intersection LOS	D											

Movement	EBL	EBT	EBR	WBL	WBT	WBR	NBL	NBT	NBR	SBL	SBT	SBR
Lane Configurations		↔	↔		↔	↔		↔			↔	
Traffic Vol, veh/h	93	426	128	12	347	83	0	0	1	114	33	110
Future Vol, veh/h	93	426	128	12	347	83	0	0	1	114	33	110
Peak Hour Factor	0.92	0.92	0.92	0.92	0.92	0.92	0.92	0.92	0.92	0.92	0.92	0.92
Heavy Vehicles, %	2	2	2	2	2	2	2	2	2	2	2	2
Mvmt Flow	101	463	139	13	377	90	0	0	1	124	36	120
Number of Lanes	0	1	1	0	1	1	0	1	0	0	1	0

Approach	EB	WB	NB	SB
Opposing Approach	WB	EB	SB	NB
Opposing Lanes	2	2	1	1
Conflicting Approach Left	SB	NB	EB	WB
Conflicting Lanes Left	1	1	2	2
Conflicting Approach Right	NB	SB	WB	EB
Conflicting Lanes Right	1	1	2	2
HCM Control Delay	50.3	21.1	10.4	16.3
HCM LOS	F	C	B	C

Lane	NBLn1	EBLn1	EBLn2	WBLn1	WBLn2	SBLn1
Vol Left, %	0%	18%	0%	3%	0%	44%
Vol Thru, %	0%	82%	0%	97%	0%	13%
Vol Right, %	100%	0%	100%	0%	100%	43%
Sign Control	Stop	Stop	Stop	Stop	Stop	Stop
Traffic Vol by Lane	1	519	128	359	83	257
LT Vol	0	93	0	12	0	114
Through Vol	0	426	0	347	0	33
RT Vol	1	0	128	0	83	110
Lane Flow Rate	1	564	139	390	90	279
Geometry Grp	2	7	7	7	7	2
Degree of Util (X)	0.002	0.99	0.213	0.708	0.145	0.509
Departure Headway (Hd)	7.38	6.319	5.515	6.53	5.799	6.562
Convergence, Y/N	Yes	Yes	Yes	Yes	Yes	Yes
Cap	488	570	646	550	613	545
Service Time	5.38	4.094	3.29	4.315	3.583	4.643
HCM Lane V/C Ratio	0.002	0.989	0.215	0.709	0.147	0.512
HCM Control Delay	10.4	60.3	9.8	23.8	9.6	16.3
HCM Lane LOS	B	F	A	C	A	C
HCM 95th-tile Q	0	14.1	0.8	5.7	0.5	2.9

Heritage at Dalia Ranch
8: Imperial Ave & Aten Rd

Opening Year 2028 + P1-4 Proj
Timing Plan: AM PEAK



Movement	EBL	EBT	EBR	WBL	WBT	WBR	NBL	NBT	NBR	SBL	SBT	SBR
Lane Configurations												
Traffic Volume (veh/h)	236	362	67	140	321	179	65	475	72	194	959	468
Future Volume (veh/h)	236	362	67	140	321	179	65	475	72	194	959	468
Initial Q (Qb), veh	0	0	0	0	0	0	0	0	0	0	0	0
Ped-Bike Adj(A_pbT)	1.00		1.00	1.00		1.00	1.00		1.00	1.00		1.00
Parking Bus, Adj	1.00	1.00	1.00	1.00	1.00	1.00	1.00	1.00	1.00	1.00	1.00	1.00
Work Zone On Approach		No			No			No			No	
Adj Sat Flow, veh/h/ln	1870	1870	1870	1870	1870	1870	1870	1870	1870	1870	1870	1870
Adj Flow Rate, veh/h	274	421	78	163	373	208	76	552	84	226	1115	544
Peak Hour Factor	0.86	0.86	0.86	0.86	0.86	0.86	0.86	0.86	0.86	0.86	0.86	0.86
Percent Heavy Veh, %	2	2	2	2	2	2	2	2	2	2	2	2
Cap, veh/h	301	780	143	202	454	249	97	794	354	254	1107	494
Arrive On Green	0.17	0.26	0.26	0.11	0.21	0.21	0.05	0.22	0.22	0.14	0.31	0.31
Sat Flow, veh/h	1781	2997	551	1781	2213	1215	1781	3554	1585	1781	3554	1585
Grp Volume(v), veh/h	274	248	251	163	298	283	76	552	84	226	1115	544
Grp Sat Flow(s),veh/h/ln	1781	1777	1771	1781	1777	1652	1781	1777	1585	1781	1777	1585
Q Serve(g_s), s	11.6	9.3	9.4	6.9	12.4	12.6	3.2	11.0	3.3	9.6	24.0	24.0
Cycle Q Clear(g_c), s	11.6	9.3	9.4	6.9	12.4	12.6	3.2	11.0	3.3	9.6	24.0	24.0
Prop In Lane	1.00		0.31	1.00		0.74	1.00		1.00	1.00		1.00
Lane Grp Cap(c), veh/h	301	463	461	202	365	339	97	794	354	254	1107	494
V/C Ratio(X)	0.91	0.54	0.54	0.81	0.82	0.83	0.78	0.70	0.24	0.89	1.01	1.10
Avail Cap(c_a), veh/h	301	463	461	301	415	386	116	831	370	254	1107	494
HCM Platoon Ratio	1.00	1.00	1.00	1.00	1.00	1.00	1.00	1.00	1.00	1.00	1.00	1.00
Upstream Filter(l)	1.00	1.00	1.00	1.00	1.00	1.00	1.00	1.00	1.00	1.00	1.00	1.00
Uniform Delay (d), s/veh	31.4	24.5	24.5	33.3	29.2	29.3	35.9	27.5	24.5	32.4	26.5	26.5
Incr Delay (d2), s/veh	30.2	1.2	1.3	9.4	10.9	13.2	24.3	2.4	0.3	29.3	28.7	71.0
Initial Q Delay(d3),s/veh	0.0	0.0	0.0	0.0	0.0	0.0	0.0	0.0	0.0	0.0	0.0	0.0
%ile BackOfQ(50%),veh/ln	7.3	3.9	3.9	3.4	6.2	6.1	2.0	4.8	1.2	6.1	14.0	18.2
Unsig. Movement Delay, s/veh												
LnGrp Delay(d),s/veh	61.6	25.7	25.9	42.7	40.2	42.5	60.3	29.9	24.9	61.7	55.2	97.5
LnGrp LOS	E	C	C	D	D	D	E	C	C	E	F	F
Approach Vol, veh/h		773			744			712			1885	
Approach Delay, s/veh		38.5			41.6			32.5			68.2	
Approach LOS		D			D			C			E	
Timer - Assigned Phs	1	2	3	4	5	6	7	8				
Phs Duration (G+Y+Rc), s	6.0	22.2	13.8	25.1	9.2	29.0	18.0	20.8				
Change Period (Y+Rc), s	5.0	5.0	5.0	5.0	5.0	5.0	5.0	5.0				
Max Green Setting (Gmax), s	18.0	18.0	13.0	18.0	5.0	24.0	13.0	18.0				
Max Q Clear Time (g_c+ll), s	13.0	13.0	8.9	11.4	5.2	26.0	13.6	14.6				
Green Ext Time (p_c), s	0.0	1.8	0.2	1.6	0.0	0.0	0.0	1.2				
Intersection Summary												
HCM 6th Ctrl Delay											51.6	
HCM 6th LOS											D	

Intersection						
Int Delay, s/veh	1.7					
Movement	EBL	EBT	WBT	WBR	SBL	SBR
Lane Configurations	↖	↑	↗		↖	↗
Traffic Vol, veh/h	3	174	137	18	52	7
Future Vol, veh/h	3	174	137	18	52	7
Conflicting Peds, #/hr	0	0	0	0	0	0
Sign Control	Free	Free	Free	Free	Stop	Stop
RT Channelized	-	None	-	None	-	None
Storage Length	50	-	-	-	0	0
Veh in Median Storage, #	-	0	0	-	0	-
Grade, %	-	0	0	-	0	-
Peak Hour Factor	92	92	92	92	92	92
Heavy Vehicles, %	2	2	2	2	2	2
Mvmt Flow	3	189	149	20	57	8

Major/Minor	Major1	Major2	Minor2		
Conflicting Flow All	169	0	-	0	354 159
Stage 1	-	-	-	-	159 -
Stage 2	-	-	-	-	195 -
Critical Hdwy	4.12	-	-	-	6.42 6.22
Critical Hdwy Stg 1	-	-	-	-	5.42 -
Critical Hdwy Stg 2	-	-	-	-	5.42 -
Follow-up Hdwy	2.218	-	-	-	3.518 3.318
Pot Cap-1 Maneuver	1409	-	-	-	644 886
Stage 1	-	-	-	-	870 -
Stage 2	-	-	-	-	838 -
Platoon blocked, %		-	-	-	
Mov Cap-1 Maneuver	1409	-	-	-	643 886
Mov Cap-2 Maneuver	-	-	-	-	643 -
Stage 1	-	-	-	-	868 -
Stage 2	-	-	-	-	838 -

Approach	EB	WB	SB
HCM Control Delay, s	0.1	0	10.9
HCM LOS			B

Minor Lane/Major Mvmt	EBL	EBT	WBT	WBR	SBLn1	SBLn2
Capacity (veh/h)	1409	-	-	-	643	886
HCM Lane V/C Ratio	0.002	-	-	-	0.088	0.009
HCM Control Delay (s)	7.6	-	-	-	11.1	9.1
HCM Lane LOS	A	-	-	-	B	A
HCM 95th %tile Q(veh)	0	-	-	-	0.3	0

Intersection												
Int Delay, s/veh	5.5											
Movement	EBL	EBT	EBR	WBL	WBT	WBR	NBL	NBT	NBR	SBL	SBT	SBR
Lane Configurations		↕	↕		↕	↕	↕	↕		↕	↕	
Traffic Vol, veh/h	22	0	90	7	0	0	30	43	3	0	32	8
Future Vol, veh/h	22	0	90	7	0	0	30	43	3	0	32	8
Conflicting Peds, #/hr	0	0	0	0	0	0	0	0	0	0	0	0
Sign Control	Stop	Stop	Stop	Stop	Stop	Stop	Free	Free	Free	Free	Free	Free
RT Channelized	-	-	None	-	-	None	-	-	None	-	-	None
Storage Length	-	-	0	-	-	0	0	-	-	50	-	-
Veh in Median Storage, #	-	0	-	-	0	-	-	0	-	-	0	-
Grade, %	-	0	-	-	0	-	-	0	-	-	0	-
Peak Hour Factor	92	92	92	92	92	92	92	92	92	92	92	92
Heavy Vehicles, %	2	2	2	2	2	2	2	2	2	2	2	2
Mvmt Flow	24	0	98	8	0	0	33	47	3	0	35	9

Major/Minor	Minor2		Minor1		Major1			Major2				
Conflicting Flow All	155	156	40	204	159	49	44	0	0	50	0	0
Stage 1	40	40	-	115	115	-	-	-	-	-	-	-
Stage 2	115	116	-	89	44	-	-	-	-	-	-	-
Critical Hdwy	7.12	6.52	6.22	7.12	6.52	6.22	4.12	-	-	4.12	-	-
Critical Hdwy Stg 1	6.12	5.52	-	6.12	5.52	-	-	-	-	-	-	-
Critical Hdwy Stg 2	6.12	5.52	-	6.12	5.52	-	-	-	-	-	-	-
Follow-up Hdwy	3.518	4.018	3.318	3.518	4.018	3.318	2.218	-	-	2.218	-	-
Pot Cap-1 Maneuver	812	736	1031	754	733	1020	1564	-	-	1557	-	-
Stage 1	975	862	-	890	800	-	-	-	-	-	-	-
Stage 2	890	800	-	918	858	-	-	-	-	-	-	-
Platoon blocked, %								-	-	-	-	-
Mov Cap-1 Maneuver	799	721	1031	672	718	1020	1564	-	-	1557	-	-
Mov Cap-2 Maneuver	799	721	-	672	718	-	-	-	-	-	-	-
Stage 1	955	862	-	871	783	-	-	-	-	-	-	-
Stage 2	871	783	-	831	858	-	-	-	-	-	-	-

Approach	EB		WB		NB		SB	
HCM Control Delay, s	9		10.4		2.9		0	
HCM LOS	A		B					

Minor Lane/Major Mvmt	NBL	NBT	NBR	EBLn1	EBLn2	WBLn1	WBLn2	SBL	SBT	SBR
Capacity (veh/h)	1564	-	-	799	1031	672	-	1557	-	-
HCM Lane V/C Ratio	0.021	-	-	0.03	0.095	0.011	-	-	-	-
HCM Control Delay (s)	7.4	-	-	9.6	8.9	10.4	0	0	-	-
HCM Lane LOS	A	-	-	A	A	B	A	A	-	-
HCM 95th %tile Q(veh)	0.1	-	-	0.1	0.3	0	-	0	-	-

Intersection						
Int Delay, s/veh	4.7					
Movement	EBT	EBR	WBL	WBT	NBL	NBR
Lane Configurations	↔		↔	↑	↔	↔
Traffic Vol, veh/h	54	0	28	36	0	81
Future Vol, veh/h	54	0	28	36	0	81
Conflicting Peds, #/hr	0	0	0	0	0	0
Sign Control	Free	Free	Free	Free	Stop	Stop
RT Channelized	-	None	-	None	-	None
Storage Length	-	-	50	-	0	0
Veh in Median Storage, #	0	-	-	0	0	-
Grade, %	0	-	-	0	0	-
Peak Hour Factor	92	92	92	92	92	92
Heavy Vehicles, %	2	2	2	2	2	2
Mvmt Flow	59	0	30	39	0	88

Major/Minor	Major1	Major2	Minor1		
Conflicting Flow All	0	0	59	0	158
Stage 1	-	-	-	-	59
Stage 2	-	-	-	-	99
Critical Hdwy	-	-	4.12	-	6.42
Critical Hdwy Stg 1	-	-	-	-	5.42
Critical Hdwy Stg 2	-	-	-	-	5.42
Follow-up Hdwy	-	-	2.218	-	3.518
Pot Cap-1 Maneuver	-	-	1545	-	833
Stage 1	-	-	-	-	964
Stage 2	-	-	-	-	925
Platoon blocked, %	-	-	-	-	-
Mov Cap-1 Maneuver	-	-	1545	-	817
Mov Cap-2 Maneuver	-	-	-	-	817
Stage 1	-	-	-	-	964
Stage 2	-	-	-	-	907

Approach	EB	WB	NB
HCM Control Delay, s	0	3.2	8.9
HCM LOS			A

Minor Lane/Major Mvmt	NBLn1	NBLn2	EBT	EBR	WBL	WBT
Capacity (veh/h)	-	1007	-	-	1545	-
HCM Lane V/C Ratio	-	0.087	-	-	0.02	-
HCM Control Delay (s)	0	8.9	-	-	7.4	-
HCM Lane LOS	A	A	-	-	A	-
HCM 95th %tile Q(veh)	-	0.3	-	-	0.1	-

Intersection						
Int Delay, s/veh	2.2					
Movement	EBT	EBR	WBL	WBT	NBL	NBR
Lane Configurations	↔		↔	↑	↔	↔
Traffic Vol, veh/h	133	2	16	59	5	42
Future Vol, veh/h	133	2	16	59	5	42
Conflicting Peds, #/hr	0	0	0	0	0	0
Sign Control	Free	Free	Free	Free	Stop	Stop
RT Channelized	-	None	-	None	-	None
Storage Length	-	-	50	-	0	0
Veh in Median Storage, #	0	-	-	0	0	-
Grade, %	0	-	-	0	0	-
Peak Hour Factor	92	92	92	92	92	92
Heavy Vehicles, %	2	2	2	2	2	2
Mvmt Flow	145	2	17	64	5	46

Major/Minor	Major1	Major2	Minor1		
Conflicting Flow All	0	0	147	0	244
Stage 1	-	-	-	-	146
Stage 2	-	-	-	-	98
Critical Hdwy	-	-	4.12	-	6.42
Critical Hdwy Stg 1	-	-	-	-	5.42
Critical Hdwy Stg 2	-	-	-	-	5.42
Follow-up Hdwy	-	-	2.218	-	3.518
Pot Cap-1 Maneuver	-	-	1435	-	744
Stage 1	-	-	-	-	881
Stage 2	-	-	-	-	926
Platoon blocked, %	-	-	-	-	-
Mov Cap-1 Maneuver	-	-	1435	-	735
Mov Cap-2 Maneuver	-	-	-	-	735
Stage 1	-	-	-	-	881
Stage 2	-	-	-	-	915

Approach	EB	WB	NB
HCM Control Delay, s	0	1.6	9.3
HCM LOS			A

Minor Lane/Major Mvmt	NBLn1	NBLn2	EBT	EBR	WBL	WBT
Capacity (veh/h)	735	901	-	-	1435	-
HCM Lane V/C Ratio	0.007	0.051	-	-	0.012	-
HCM Control Delay (s)	9.9	9.2	-	-	7.5	-
HCM Lane LOS	A	A	-	-	A	-
HCM 95th %tile Q(veh)	0	0.2	-	-	0	-

Intersection						
Int Delay, s/veh	5.8					
Movement	EBT	EBR	WBL	WBT	NBL	NBR
Lane Configurations	↔		↔	↑	↔	↔
Traffic Vol, veh/h	145	30	242	52	23	116
Future Vol, veh/h	145	30	242	52	23	116
Conflicting Peds, #/hr	0	0	0	0	0	0
Sign Control	Free	Free	Free	Free	Stop	Stop
RT Channelized	-	None	-	None	-	None
Storage Length	-	-	100	-	0	0
Veh in Median Storage, #	0	-	-	0	0	-
Grade, %	0	-	-	0	0	-
Peak Hour Factor	92	92	92	92	92	92
Heavy Vehicles, %	2	2	2	2	2	2
Mvmt Flow	158	33	263	57	25	126

Major/Minor	Major1	Major2	Minor1		
Conflicting Flow All	0	0	191	0	758
Stage 1	-	-	-	-	175
Stage 2	-	-	-	-	583
Critical Hdwy	-	-	4.12	-	6.42
Critical Hdwy Stg 1	-	-	-	-	5.42
Critical Hdwy Stg 2	-	-	-	-	5.42
Follow-up Hdwy	-	-	2.218	-	3.518
Pot Cap-1 Maneuver	-	-	1383	-	375
Stage 1	-	-	-	-	855
Stage 2	-	-	-	-	558
Platoon blocked, %	-	-	-	-	-
Mov Cap-1 Maneuver	-	-	1383	-	304
Mov Cap-2 Maneuver	-	-	-	-	304
Stage 1	-	-	-	-	855
Stage 2	-	-	-	-	452

Approach	EB	WB	NB
HCM Control Delay, s	0	6.8	11.2
HCM LOS			B

Minor Lane/Major Mvmt	NBLn1	NBLn2	EBT	EBR	WBL	WBT
Capacity (veh/h)	304	868	-	-	1383	-
HCM Lane V/C Ratio	0.082	0.145	-	-	0.19	-
HCM Control Delay (s)	17.9	9.9	-	-	8.2	-
HCM Lane LOS	C	A	-	-	A	-
HCM 95th %tile Q(veh)	0.3	0.5	-	-	0.7	-

Intersection						
Int Delay, s/veh	0.7					
Movement	EBL	EBR	NBL	NBT	SBT	SBR
Lane Configurations		↗		↕↕	↕↕	↗
Traffic Vol, veh/h	0	92	0	775	730	30
Future Vol, veh/h	0	92	0	775	730	30
Conflicting Peds, #/hr	0	0	0	0	0	0
Sign Control	Stop	Stop	Free	Free	Free	Free
RT Channelized	-	None	-	None	-	None
Storage Length	-	0	-	-	-	100
Veh in Median Storage, #	0	-	-	0	0	-
Grade, %	0	-	-	0	0	-
Peak Hour Factor	92	92	92	92	92	92
Heavy Vehicles, %	2	2	2	2	2	2
Mvmt Flow	0	100	0	842	793	33

Major/Minor	Minor2	Major1	Major2
Conflicting Flow All	-	397	0
Stage 1	-	-	-
Stage 2	-	-	-
Critical Hdwy	-	6.94	-
Critical Hdwy Stg 1	-	-	-
Critical Hdwy Stg 2	-	-	-
Follow-up Hdwy	-	3.32	-
Pot Cap-1 Maneuver	0	602	0
Stage 1	0	-	0
Stage 2	0	-	0
Platoon blocked, %			-
Mov Cap-1 Maneuver	-	602	-
Mov Cap-2 Maneuver	-	-	-
Stage 1	-	-	-
Stage 2	-	-	-

Approach	EB	NB	SB
HCM Control Delay, s	12.2	0	0
HCM LOS	B		

Minor Lane/Major Mvmt	NBT EBLn1	SBT	SBR
Capacity (veh/h)	- 602	-	-
HCM Lane V/C Ratio	- 0.166	-	-
HCM Control Delay (s)	- 12.2	-	-
HCM Lane LOS	- B	-	-
HCM 95th %tile Q(veh)	- 0.6	-	-

Heritage at Dalia Ranch
1: SR-86 & Keystone Rd

Opening Year 2028 + P1-4 Proj
Timing Plan: PM PEAK

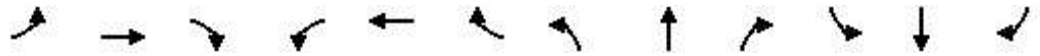

Movement	EBL	EBT	EBR	WBL	WBT	WBR	NBL	NBT	NBR	SBL	SBT	SBR
Lane Configurations		↕			↕		↕	↕↕	↕	↕	↕↕	↕
Traffic Volume (veh/h)	44	13	21	35	29	40	11	672	28	56	734	36
Future Volume (veh/h)	44	13	21	35	29	40	11	672	28	56	734	36
Initial Q (Qb), veh	0	0	0	0	0	0	0	0	0	0	0	0
Ped-Bike Adj(A_pbT)	1.00		1.00	1.00		1.00	1.00		1.00	1.00		1.00
Parking Bus, Adj	1.00	1.00	1.00	1.00	1.00	1.00	1.00	1.00	1.00	1.00	1.00	1.00
Work Zone On Approach		No			No			No			No	
Adj Sat Flow, veh/h/ln	1870	1870	1870	1870	1870	1870	1870	1870	1870	1870	1870	1870
Adj Flow Rate, veh/h	49	15	24	39	33	45	12	755	31	63	825	40
Peak Hour Factor	0.89	0.89	0.89	0.89	0.89	0.89	0.89	0.89	0.89	0.89	0.89	0.89
Percent Heavy Veh, %	2	2	2	2	2	2	2	2	2	2	2	2
Cap, veh/h	266	51	56	200	71	80	28	1288	575	118	1467	654
Arrive On Green	0.13	0.13	0.13	0.13	0.13	0.13	0.02	0.36	0.36	0.07	0.41	0.41
Sat Flow, veh/h	790	400	446	454	562	635	1781	3554	1585	1781	3554	1585
Grp Volume(v), veh/h	88	0	0	117	0	0	12	755	31	63	825	40
Grp Sat Flow(s),veh/h/ln	1636	0	0	1650	0	0	1781	1777	1585	1781	1777	1585
Q Serve(g_s), s	0.0	0.0	0.0	0.6	0.0	0.0	0.2	5.8	0.4	1.2	6.0	0.5
Cycle Q Clear(g_c), s	1.5	0.0	0.0	2.1	0.0	0.0	0.2	5.8	0.4	1.2	6.0	0.5
Prop In Lane	0.56		0.27	0.33		0.38	1.00		1.00	1.00		1.00
Lane Grp Cap(c), veh/h	373	0	0	351	0	0	28	1288	575	118	1467	654
V/C Ratio(X)	0.24	0.00	0.00	0.33	0.00	0.00	0.43	0.59	0.05	0.54	0.56	0.06
Avail Cap(c_a), veh/h	968	0	0	991	0	0	264	2213	987	317	2319	1034
HCM Platoon Ratio	1.00	1.00	1.00	1.00	1.00	1.00	1.00	1.00	1.00	1.00	1.00	1.00
Upstream Filter(l)	1.00	0.00	0.00	1.00	0.00	0.00	1.00	1.00	1.00	1.00	1.00	1.00
Uniform Delay (d), s/veh	13.5	0.0	0.0	13.8	0.0	0.0	16.4	8.7	7.0	15.2	7.6	6.0
Incr Delay (d2), s/veh	0.3	0.0	0.0	0.6	0.0	0.0	10.0	0.4	0.0	3.7	0.3	0.0
Initial Q Delay(d3),s/veh	0.0	0.0	0.0	0.0	0.0	0.0	0.0	0.0	0.0	0.0	0.0	0.0
%ile BackOfQ(50%),veh/ln	0.5	0.0	0.0	0.7	0.0	0.0	0.2	1.5	0.1	0.5	1.5	0.1
Unsig. Movement Delay, s/veh												
LnGrp Delay(d),s/veh	13.8	0.0	0.0	14.3	0.0	0.0	26.4	9.1	7.0	19.0	7.9	6.0
LnGrp LOS	B	A	A	B	A	A	C	A	A	B	A	A
Approach Vol, veh/h		88			117			798			928	
Approach Delay, s/veh		13.8			14.3			9.3			8.6	
Approach LOS		B			B			A			A	
Timer - Assigned Phs	1	2		4	5	6		8				
Phs Duration (G+Y+Rc), s	7.2	17.2		9.3	5.5	18.9		9.3				
Change Period (Y+Rc), s	5.0	5.0		5.0	5.0	5.0		5.0				
Max Green Setting (Gmax), s	6.0	21.0		18.0	5.0	22.0		18.0				
Max Q Clear Time (g_c+I1), s	3.2	7.8		3.5	2.2	8.0		4.1				
Green Ext Time (p_c), s	0.0	4.4		0.3	0.0	5.0		0.4				
Intersection Summary												
HCM 6th Ctrl Delay				9.5								
HCM 6th LOS				A								

Intersection												
Int Delay, s/veh	0.4											
Movement	EBL	EBT	EBR	WBL	WBT	WBR	NBL	NBT	NBR	SBL	SBT	SBR
Lane Configurations		↕			↕		↕	↕		↕	↕	
Traffic Vol, veh/h	7	4	0	8	0	6	1	713	8	7	772	19
Future Vol, veh/h	7	4	0	8	0	6	1	713	8	7	772	19
Conflicting Peds, #/hr	0	0	0	0	0	0	0	0	0	0	0	0
Sign Control	Stop	Stop	Stop	Stop	Stop	Stop	Free	Free	Free	Free	Free	Free
RT Channelized	-	-	None	-	-	None	-	-	None	-	-	None
Storage Length	-	-	-	-	-	-	50	-	-	50	-	-
Veh in Median Storage, #	-	1	-	-	1	-	-	0	-	-	0	-
Grade, %	-	0	-	-	0	-	-	0	-	-	0	-
Peak Hour Factor	92	92	92	92	92	92	92	92	92	92	92	92
Heavy Vehicles, %	2	2	2	2	2	2	2	2	2	2	2	2
Mvmt Flow	8	4	0	9	0	7	1	775	9	8	839	21

Major/Minor	Minor2		Minor1		Major1		Major2					
Conflicting Flow All	1256	1652	430	1220	1658	392	860	0	0	784	0	0
Stage 1	866	866	-	782	782	-	-	-	-	-	-	-
Stage 2	390	786	-	438	876	-	-	-	-	-	-	-
Critical Hdwy	7.54	6.54	6.94	7.54	6.54	6.94	4.14	-	-	4.14	-	-
Critical Hdwy Stg 1	6.54	5.54	-	6.54	5.54	-	-	-	-	-	-	-
Critical Hdwy Stg 2	6.54	5.54	-	6.54	5.54	-	-	-	-	-	-	-
Follow-up Hdwy	3.52	4.02	3.32	3.52	4.02	3.32	2.22	-	-	2.22	-	-
Pot Cap-1 Maneuver	128	98	573	136	97	607	777	-	-	830	-	-
Stage 1	314	369	-	353	403	-	-	-	-	-	-	-
Stage 2	606	401	-	567	365	-	-	-	-	-	-	-
Platoon blocked, %								-	-	-	-	-
Mov Cap-1 Maneuver	126	97	573	133	96	607	777	-	-	830	-	-
Mov Cap-2 Maneuver	237	217	-	253	217	-	-	-	-	-	-	-
Stage 1	314	365	-	353	403	-	-	-	-	-	-	-
Stage 2	599	401	-	555	361	-	-	-	-	-	-	-

Approach	EB		WB		NB		SB	
HCM Control Delay, s	21.6		16.2		0		0.1	
HCM LOS	C		C					

Minor Lane/Major Mvmt	NBL	NBT	NBR	EBLn1	WBLn1	SBL	SBT	SBR
Capacity (veh/h)	777	-	-	229	337	830	-	-
HCM Lane V/C Ratio	0.001	-	-	0.052	0.045	0.009	-	-
HCM Control Delay (s)	9.6	-	-	21.6	16.2	9.4	-	-
HCM Lane LOS	A	-	-	C	C	A	-	-
HCM 95th %tile Q(veh)	0	-	-	0.2	0.1	0	-	-

Heritage at Dalia Ranch
3: Imperial Ave & Ralph Rd

Opening Year 2028 + P1-4 Proj
Timing Plan: PM PEAK

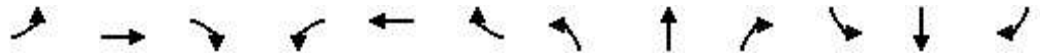

Movement	EBL	EBT	EBR	WBL	WBT	WBR	NBL	NBT	NBR	SBL	SBT	SBR
Lane Configurations												
Traffic Volume (veh/h)	81	22	90	58	18	23	192	621	96	53	629	84
Future Volume (veh/h)	81	22	90	58	18	23	192	621	96	53	629	84
Initial Q (Qb), veh	0	0	0	0	0	0	0	0	0	0	0	0
Ped-Bike Adj(A_pbT)	1.00		1.00	1.00		1.00	1.00		1.00	1.00		1.00
Parking Bus, Adj	1.00	1.00	1.00	1.00	1.00	1.00	1.00	1.00	1.00	1.00	1.00	1.00
Work Zone On Approach		No			No			No			No	
Adj Sat Flow, veh/h/ln	1870	1870	1870	1870	1870	1870	1870	1870	1870	1870	1870	1870
Adj Flow Rate, veh/h	88	24	98	64	20	25	209	682	105	58	691	91
Peak Hour Factor	0.92	0.92	0.92	0.91	0.92	0.91	0.92	0.91	0.91	0.91	0.91	0.92
Percent Heavy Veh, %	2	2	2	2	2	2	2	2	2	2	2	2
Cap, veh/h	173	38	153	166	85	106	213	1039	160	98	968	432
Arrive On Green	0.10	0.12	0.12	0.09	0.11	0.11	0.12	0.34	0.34	0.06	0.27	0.27
Sat Flow, veh/h	1781	321	1313	1781	756	945	1781	3087	475	1781	3554	1585
Grp Volume(v), veh/h	88	0	122	64	0	45	209	392	395	58	691	91
Grp Sat Flow(s),veh/h/ln	1781	0	1634	1781	0	1700	1781	1777	1785	1781	1777	1585
Q Serve(g_s), s	2.4	0.0	3.6	1.7	0.0	1.2	5.9	9.4	9.5	1.6	8.8	2.2
Cycle Q Clear(g_c), s	2.4	0.0	3.6	1.7	0.0	1.2	5.9	9.4	9.5	1.6	8.8	2.2
Prop In Lane	1.00		0.80	1.00		0.56	1.00		0.27	1.00		1.00
Lane Grp Cap(c), veh/h	173	0	191	166	0	192	213	598	601	98	968	432
V/C Ratio(X)	0.51	0.00	0.64	0.39	0.00	0.23	0.98	0.66	0.66	0.59	0.71	0.21
Avail Cap(c_a), veh/h	638	0	585	638	0	609	213	672	675	177	1273	568
HCM Platoon Ratio	1.00	1.00	1.00	1.00	1.00	1.00	1.00	1.00	1.00	1.00	1.00	1.00
Upstream Filter(I)	1.00	0.00	1.00	1.00	0.00	1.00	1.00	1.00	1.00	1.00	1.00	1.00
Uniform Delay (d), s/veh	21.5	0.0	21.2	21.4	0.0	20.3	22.1	14.2	14.2	23.2	16.5	14.1
Incr Delay (d2), s/veh	2.3	0.0	3.5	1.5	0.0	0.6	56.5	2.0	2.0	5.5	1.3	0.2
Initial Q Delay(d3),s/veh	0.0	0.0	0.0	0.0	0.0	0.0	0.0	0.0	0.0	0.0	0.0	0.0
%ile BackOfQ(50%),veh/ln	1.0	0.0	1.4	0.7	0.0	0.5	5.6	3.5	3.6	0.8	3.3	0.7
Unsig. Movement Delay, s/veh												
LnGrp Delay(d),s/veh	23.8	0.0	24.7	22.9	0.0	20.9	78.5	16.1	16.2	28.7	17.8	14.3
LnGrp LOS	C	A	C	C	A	C	E	B	B	C	B	B
Approach Vol, veh/h		210			109			996			840	
Approach Delay, s/veh		24.3			22.1			29.2			18.2	
Approach LOS		C			C			C			B	
Timer - Assigned Phs	1	2	3	4	5	6	7	8				
Phs Duration (G+Y+Rc), s	7.8	21.9	9.7	10.9	11.0	18.7	9.9	10.7				
Change Period (Y+Rc), s	5.0	5.0	5.0	5.0	5.0	5.0	5.0	5.0				
Max Green Setting (Gmax), s	5.0	19.0	18.0	18.0	6.0	18.0	18.0	18.0				
Max Q Clear Time (g_c+I1), s	3.6	11.5	3.7	5.6	7.9	10.8	4.4	3.2				
Green Ext Time (p_c), s	0.0	3.0	0.1	0.5	0.0	2.9	0.1	0.1				
Intersection Summary												
HCM 6th Ctrl Delay			24.1									
HCM 6th LOS			C									

Heritage at Dalia Ranch
4: Imperial Ave & Neckel Rd

Opening Year 2028 + P1-4 Proj
Timing Plan: PM PEAK



Movement	EBL	EBT	EBR	WBL	WBT	WBR	NBL	NBT	NBR	SBL	SBT	SBR
Lane Configurations		↕			↕		↕	↕		↕	↕	
Traffic Volume (veh/h)	13	28	90	141	21	86	159	834	180	83	723	30
Future Volume (veh/h)	13	28	90	141	21	86	159	834	180	83	723	30
Initial Q (Qb), veh	0	0	0	0	0	0	0	0	0	0	0	0
Ped-Bike Adj(A_pbT)	1.00		1.00	1.00		1.00	1.00		1.00	1.00		1.00
Parking Bus, Adj	1.00	1.00	1.00	1.00	1.00	1.00	1.00	1.00	1.00	1.00	1.00	1.00
Work Zone On Approach		No			No			No			No	
Adj Sat Flow, veh/h/ln	1870	1870	1870	1870	1870	1870	1870	1870	1870	1870	1870	1870
Adj Flow Rate, veh/h	14	30	98	153	23	93	173	907	196	90	786	33
Peak Hour Factor	0.92	0.92	0.92	0.92	0.92	0.92	0.92	0.92	0.92	0.92	0.92	0.92
Percent Heavy Veh, %	2	2	2	2	2	2	2	2	2	2	2	2
Cap, veh/h	18	40	129	189	28	115	144	890	192	115	1009	42
Arrive On Green	0.11	0.11	0.11	0.19	0.19	0.19	0.08	0.31	0.31	0.06	0.29	0.29
Sat Flow, veh/h	163	350	1143	975	147	593	1781	2907	628	1781	3475	146
Grp Volume(v), veh/h	142	0	0	269	0	0	173	554	549	90	402	417
Grp Sat Flow(s),veh/h/ln	1656	0	0	1715	0	0	1781	1777	1757	1781	1777	1844
Q Serve(g_s), s	5.2	0.0	0.0	9.3	0.0	0.0	5.0	19.0	19.0	3.1	12.9	12.9
Cycle Q Clear(g_c), s	5.2	0.0	0.0	9.3	0.0	0.0	5.0	19.0	19.0	3.1	12.9	12.9
Prop In Lane	0.10		0.69	0.57		0.35	1.00		0.36	1.00		0.08
Lane Grp Cap(c), veh/h	187	0	0	332	0	0	144	544	538	115	516	535
V/C Ratio(X)	0.76	0.00	0.00	0.81	0.00	0.00	1.21	1.02	1.02	0.78	0.78	0.78
Avail Cap(c_a), veh/h	481	0	0	497	0	0	144	544	538	144	544	565
HCM Platoon Ratio	1.00	1.00	1.00	1.00	1.00	1.00	1.00	1.00	1.00	1.00	1.00	1.00
Upstream Filter(I)	1.00	0.00	0.00	1.00	0.00	0.00	1.00	1.00	1.00	1.00	1.00	1.00
Uniform Delay (d), s/veh	26.7	0.0	0.0	23.9	0.0	0.0	28.5	21.5	21.5	28.6	20.2	20.2
Incr Delay (d2), s/veh	6.2	0.0	0.0	6.0	0.0	0.0	140.7	43.4	43.9	19.4	6.8	6.6
Initial Q Delay(d3),s/veh	0.0	0.0	0.0	0.0	0.0	0.0	0.0	0.0	0.0	0.0	0.0	0.0
%ile BackOfQ(50%),veh/ln	2.2	0.0	0.0	4.1	0.0	0.0	7.6	13.7	13.6	1.9	5.8	6.0
Unsig. Movement Delay, s/veh												
LnGrp Delay(d),s/veh	32.9	0.0	0.0	29.9	0.0	0.0	169.2	64.9	65.4	48.0	27.0	26.8
LnGrp LOS	C	A	A	C	A	A	F	F	F	D	C	C
Approach Vol, veh/h		142		269			1276			909		
Approach Delay, s/veh		32.9		29.9			79.2			29.0		
Approach LOS		C		C			E			C		
Timer - Assigned Phs	1	2		4	5	6		8				
Phs Duration (G+Y+Rc), s	9.0	24.0		12.0	10.0	23.0		17.0				
Change Period (Y+Rc), s	5.0	5.0		5.0	5.0	5.0		5.0				
Max Green Setting (Gmax), s	5.0	19.0		18.0	5.0	19.0		18.0				
Max Q Clear Time (g_c+1/3), s	15.0	21.0		7.2	7.0	14.9		11.3				
Green Ext Time (p_c), s	0.0	0.0		0.5	0.0	1.9		0.8				

Intersection Summary

HCM 6th Ctrl Delay	54.0
HCM 6th LOS	D

Intersection												
Int Delay, s/veh	10.3											
Movement	EBL	EBT	EBR	WBL	WBT	WBR	NBL	NBT	NBR	SBL	SBT	SBR
Lane Configurations		↕			↕			↕			↕	
Traffic Vol, veh/h	2	41	9	29	47	193	6	50	19	146	42	8
Future Vol, veh/h	2	41	9	29	47	193	6	50	19	146	42	8
Conflicting Peds, #/hr	0	0	0	0	0	0	0	0	0	0	0	0
Sign Control	Stop	Stop	Stop	Stop	Stop	Stop	Free	Free	Free	Free	Free	Free
RT Channelized	-	-	None	-	-	None	-	-	None	-	-	None
Storage Length	-	-	-	-	-	-	-	-	-	-	-	-
Veh in Median Storage, #	-	0	-	-	0	-	-	0	-	-	0	-
Grade, %	-	0	-	-	0	-	-	0	-	-	0	-
Peak Hour Factor	79	79	79	79	79	79	79	79	79	79	79	79
Heavy Vehicles, %	2	2	2	2	2	2	2	2	2	2	2	2
Mvmt Flow	3	52	11	37	59	244	8	63	24	185	53	10

Major/Minor	Minor2		Minor1		Major1		Major2					
Conflicting Flow All	671	531	58	551	524	75	63	0	0	87	0	0
Stage 1	428	428	-	91	91	-	-	-	-	-	-	-
Stage 2	243	103	-	460	433	-	-	-	-	-	-	-
Critical Hdwy	7.12	6.52	6.22	7.12	6.52	6.22	4.12	-	-	4.12	-	-
Critical Hdwy Stg 1	6.12	5.52	-	6.12	5.52	-	-	-	-	-	-	-
Critical Hdwy Stg 2	6.12	5.52	-	6.12	5.52	-	-	-	-	-	-	-
Follow-up Hdwy	3.518	4.018	3.318	3.518	4.018	3.318	2.218	-	-	2.218	-	-
Pot Cap-1 Maneuver	370	454	1008	445	458	986	1540	-	-	1509	-	-
Stage 1	605	585	-	916	820	-	-	-	-	-	-	-
Stage 2	761	810	-	581	582	-	-	-	-	-	-	-
Platoon blocked, %								-	-	-	-	-
Mov Cap-1 Maneuver	222	395	1008	356	398	986	1540	-	-	1509	-	-
Mov Cap-2 Maneuver	222	395	-	356	398	-	-	-	-	-	-	-
Stage 1	602	511	-	911	816	-	-	-	-	-	-	-
Stage 2	528	806	-	451	508	-	-	-	-	-	-	-

Approach	EB		WB		NB		SB	
HCM Control Delay, s	15		15.5		0.6		5.7	
HCM LOS	C		C					

Minor Lane/Major Mvmt	NBL	NBT	NBR	EBLn1WBLn1	SBL	SBT	SBR
Capacity (veh/h)	1540	-	-	427	681	1509	-
HCM Lane V/C Ratio	0.005	-	-	0.154	0.5	0.122	-
HCM Control Delay (s)	7.3	0	-	15	15.5	7.7	0
HCM Lane LOS	A	A	-	C	C	A	A
HCM 95th %tile Q(veh)	0	-	-	0.5	2.8	0.4	-

Heritage at Dalia Ranch
6: Imperial Ave & Worthington Rd/Barioni Blvd

Opening Year 2028 + P1-4 Proj
Timing Plan: PM PEAK

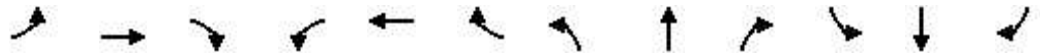

Movement	EBL	EBT	EBR	WBL	WBT	WBR	NBL	NBT	NBR	SBL	SBT	SBR
Lane Configurations		↕	↗		↕	↗	↗	↕↗		↗	↕↗	
Traffic Volume (veh/h)	78	79	112	58	120	107	120	1114	15	70	910	82
Future Volume (veh/h)	78	79	112	58	120	107	120	1114	15	70	910	82
Initial Q (Qb), veh	0	0	0	0	0	0	0	0	0	0	0	0
Ped-Bike Adj(A_pbT)	1.00		1.00	1.00		1.00	1.00		1.00	1.00		1.00
Parking Bus, Adj	1.00	1.00	1.00	1.00	1.00	1.00	1.00	1.00	1.00	1.00	1.00	1.00
Work Zone On Approach		No			No			No			No	
Adj Sat Flow, veh/h/ln	1870	1870	1870	1870	1870	1870	1870	1870	1870	1870	1870	1870
Adj Flow Rate, veh/h	86	87	123	64	132	118	132	1224	16	77	1000	90
Peak Hour Factor	0.91	0.91	0.91	0.91	0.91	0.91	0.91	0.91	0.91	0.91	0.91	0.91
Percent Heavy Veh, %	2	2	2	2	2	2	2	2	2	2	2	2
Cap, veh/h	119	121	209	86	178	227	166	1397	18	99	1157	104
Arrive On Green	0.13	0.13	0.13	0.14	0.14	0.14	0.09	0.39	0.39	0.06	0.35	0.35
Sat Flow, veh/h	907	918	1585	601	1239	1585	1781	3592	47	1781	3297	297
Grp Volume(v), veh/h	173	0	123	196	0	118	132	605	635	77	539	551
Grp Sat Flow(s),veh/h/ln	1825	0	1585	1840	0	1585	1781	1777	1862	1781	1777	1817
Q Serve(g_s), s	6.5	0.0	5.2	7.3	0.0	4.9	5.2	22.5	22.5	3.0	20.1	20.1
Cycle Q Clear(g_c), s	6.5	0.0	5.2	7.3	0.0	4.9	5.2	22.5	22.5	3.0	20.1	20.1
Prop In Lane	0.50		1.00	0.33		1.00	1.00		0.03	1.00		0.16
Lane Grp Cap(c), veh/h	240	0	209	264	0	227	166	691	724	99	624	638
V/C Ratio(X)	0.72	0.00	0.59	0.74	0.00	0.52	0.79	0.88	0.88	0.78	0.86	0.86
Avail Cap(c_a), veh/h	461	0	400	465	0	400	175	723	758	125	673	688
HCM Platoon Ratio	1.00	1.00	1.00	1.00	1.00	1.00	1.00	1.00	1.00	1.00	1.00	1.00
Upstream Filter(I)	1.00	0.00	1.00	1.00	0.00	1.00	1.00	1.00	1.00	1.00	1.00	1.00
Uniform Delay (d), s/veh	29.7	0.0	29.1	29.3	0.0	28.2	31.6	20.2	20.2	33.2	21.5	21.5
Incr Delay (d2), s/veh	4.0	0.0	2.6	4.1	0.0	1.8	21.0	11.4	11.0	21.3	10.7	10.5
Initial Q Delay(d3),s/veh	0.0	0.0	0.0	0.0	0.0	0.0	0.0	0.0	0.0	0.0	0.0	0.0
%ile BackOfQ(50%),veh/ln	3.0	0.0	2.1	3.4	0.0	1.9	3.1	10.6	11.1	1.9	9.6	9.8
Unsig. Movement Delay, s/veh												
LnGrp Delay(d),s/veh	33.7	0.0	31.8	33.4	0.0	30.1	52.7	31.6	31.2	54.6	32.2	32.1
LnGrp LOS	C	A	C	C	A	C	D	C	C	D	C	C
Approach Vol, veh/h		296			314			1372			1167	
Approach Delay, s/veh		32.9			32.1			33.4			33.6	
Approach LOS		C			C			C			C	
Timer - Assigned Phs	1	2		4	5	6		8				
Phs Duration (G+Y+Rc), s	8.9	32.7		14.4	11.6	30.0		15.2				
Change Period (Y+Rc), s	5.0	5.0		5.0	5.0	5.0		5.0				
Max Green Setting (Gmax), s	5.0	29.0		18.0	7.0	27.0		18.0				
Max Q Clear Time (g_c+I1), s	5.0	24.5		8.5	7.2	22.1		9.3				
Green Ext Time (p_c), s	0.0	3.0		0.9	0.0	2.9		1.0				
Intersection Summary												
HCM 6th Ctrl Delay			33.3									
HCM 6th LOS			C									

Intersection												
Intersection Delay, s/veh	13.3											
Intersection LOS	B											

Movement	EBL	EBT	EBR	WBL	WBT	WBR	NBL	NBT	NBR	SBL	SBT	SBR
Lane Configurations		↔	↔		↔	↔		↔			↔	
Traffic Vol, veh/h	80	227	35	29	245	36	1	0	0	40	6	66
Future Vol, veh/h	80	227	35	29	245	36	1	0	0	40	6	66
Peak Hour Factor	0.80	0.80	0.80	0.80	0.80	0.80	0.80	0.80	0.80	0.80	0.80	0.80
Heavy Vehicles, %	2	2	2	2	2	2	2	2	2	2	2	2
Mvmt Flow	100	284	44	36	306	45	1	0	0	50	8	83
Number of Lanes	0	1	1	0	1	1	0	1	0	0	1	0

Approach	EB	WB	NB	SB
Opposing Approach	WB	EB	SB	NB
Opposing Lanes	2	2	1	1
Conflicting Approach Left	SB	NB	EB	WB
Conflicting Lanes Left	1	1	2	2
Conflicting Approach Right	NB	SB	WB	EB
Conflicting Lanes Right	1	1	2	2
HCM Control Delay	14.6	13.1	9.5	10.2
HCM LOS	B	B	A	B

Lane	NBLn1	EBLn1	EBLn2	WBLn1	WBLn2	SBLn1
Vol Left, %	100%	26%	0%	11%	0%	36%
Vol Thru, %	0%	74%	0%	89%	0%	5%
Vol Right, %	0%	0%	100%	0%	100%	59%
Sign Control	Stop	Stop	Stop	Stop	Stop	Stop
Traffic Vol by Lane	1	307	35	274	36	112
LT Vol	1	80	0	29	0	40
Through Vol	0	227	0	245	0	6
RT Vol	0	0	35	0	36	66
Lane Flow Rate	1	384	44	342	45	140
Geometry Grp	2	7	7	7	7	2
Degree of Util (X)	0.002	0.577	0.056	0.512	0.058	0.215
Departure Headway (Hd)	6.479	5.417	4.58	5.381	4.622	5.54
Convergence, Y/N	Yes	Yes	Yes	Yes	Yes	Yes
Cap	556	660	774	664	766	641
Service Time	4.479	3.197	2.359	3.163	2.403	3.634
HCM Lane V/C Ratio	0.002	0.582	0.057	0.515	0.059	0.218
HCM Control Delay	9.5	15.4	7.6	13.8	7.7	10.2
HCM Lane LOS	A	C	A	B	A	B
HCM 95th-tile Q	0	3.7	0.2	2.9	0.2	0.8

Heritage at Dalia Ranch
8: Imperial Ave & Aten Rd

Opening Year 2028 + P1-4 Proj
Timing Plan: PM PEAK



Movement	EBL	EBT	EBR	WBL	WBT	WBR	NBL	NBT	NBR	SBL	SBT	SBR
Lane Configurations												
Traffic Volume (veh/h)	281	295	73	191	309	183	84	982	160	161	755	280
Future Volume (veh/h)	281	295	73	191	309	183	84	982	160	161	755	280
Initial Q (Qb), veh	0	0	0	0	0	0	0	0	0	0	0	0
Ped-Bike Adj(A_pbT)	1.00		1.00	1.00		1.00	1.00		1.00	1.00		1.00
Parking Bus, Adj	1.00	1.00	1.00	1.00	1.00	1.00	1.00	1.00	1.00	1.00	1.00	1.00
Work Zone On Approach		No			No			No			No	
Adj Sat Flow, veh/h/ln	1870	1870	1870	1870	1870	1870	1870	1870	1870	1870	1870	1870
Adj Flow Rate, veh/h	299	314	78	203	329	195	89	1045	170	171	803	298
Peak Hour Factor	0.94	0.94	0.94	0.94	0.94	0.94	0.94	0.94	0.94	0.94	0.94	0.94
Percent Heavy Veh, %	2	2	2	2	2	2	2	2	2	2	2	2
Cap, veh/h	276	608	149	245	428	248	114	951	424	176	1073	479
Arrive On Green	0.15	0.21	0.21	0.14	0.20	0.20	0.06	0.27	0.27	0.10	0.30	0.30
Sat Flow, veh/h	1781	2830	693	1781	2165	1256	1781	3554	1585	1781	3554	1585
Grp Volume(v), veh/h	299	195	197	203	269	255	89	1045	170	171	803	298
Grp Sat Flow(s),veh/h/ln	1781	1777	1746	1781	1777	1644	1781	1777	1585	1781	1777	1585
Q Serve(g_s), s	11.0	6.9	7.1	7.9	10.2	10.5	3.5	19.0	6.3	6.8	14.5	11.5
Cycle Q Clear(g_c), s	11.0	6.9	7.1	7.9	10.2	10.5	3.5	19.0	6.3	6.8	14.5	11.5
Prop In Lane	1.00		0.40	1.00		0.76	1.00		1.00	1.00		1.00
Lane Grp Cap(c), veh/h	276	382	375	245	351	325	114	951	424	176	1073	479
V/C Ratio(X)	1.08	0.51	0.52	0.83	0.77	0.79	0.78	1.10	0.40	0.97	0.75	0.62
Avail Cap(c_a), veh/h	276	450	442	276	450	417	150	951	424	176	1073	479
HCM Platoon Ratio	1.00	1.00	1.00	1.00	1.00	1.00	1.00	1.00	1.00	1.00	1.00	1.00
Upstream Filter(l)	1.00	1.00	1.00	1.00	1.00	1.00	1.00	1.00	1.00	1.00	1.00	1.00
Uniform Delay (d), s/veh	30.0	24.6	24.7	29.8	26.9	27.1	32.7	26.0	21.3	31.9	22.4	21.3
Incr Delay (d2), s/veh	78.3	1.1	1.1	17.1	5.8	7.4	17.1	60.2	0.6	60.1	2.9	2.5
Initial Q Delay(d3),s/veh	0.0	0.0	0.0	0.0	0.0	0.0	0.0	0.0	0.0	0.0	0.0	0.0
%ile BackOfQ(50%),veh/ft	0.5	2.9	2.9	4.4	4.7	4.6	2.0	15.5	2.3	5.8	6.1	4.3
Unsig. Movement Delay, s/veh												
LnGrp Delay(d),s/veh	108.4	25.7	25.8	46.9	32.8	34.5	49.8	86.2	22.0	92.0	25.3	23.8
LnGrp LOS	F	C	C	D	C	C	D	F	C	F	C	C
Approach Vol, veh/h		691			727			1304			1272	
Approach Delay, s/veh		61.5			37.3			75.4			33.9	
Approach LOS		E			D			E			C	
Timer - Assigned Phs	1	2	3	4	5	6	7	8				
Phs Duration (G+Y+Rc), s	24.0	24.0	14.8	20.3	9.6	26.4	16.0	19.0				
Change Period (Y+Rc), s	5.0	5.0	5.0	5.0	5.0	5.0	5.0	5.0				
Max Green Setting (Gmax), s	19.0	19.0	11.0	18.0	6.0	20.0	11.0	18.0				
Max Q Clear Time (g_c+1/3), s	21.0	21.0	9.9	9.1	5.5	16.5	13.0	12.5				
Green Ext Time (p_c), s	0.0	0.0	0.1	1.5	0.0	2.1	0.0	1.6				

Intersection Summary

HCM 6th Ctrl Delay	52.8
HCM 6th LOS	D

Intersection						
Int Delay, s/veh	1.3					
Movement	EBL	EBT	WBT	WBR	SBL	SBR
Lane Configurations	↖	↑	↗		↖	↗
Traffic Vol, veh/h	8	97	151	59	34	5
Future Vol, veh/h	8	97	151	59	34	5
Conflicting Peds, #/hr	0	0	0	0	0	0
Sign Control	Free	Free	Free	Free	Stop	Stop
RT Channelized	-	None	-	None	-	None
Storage Length	50	-	-	-	0	0
Veh in Median Storage, #	-	0	0	-	0	-
Grade, %	-	0	0	-	0	-
Peak Hour Factor	92	92	92	92	92	92
Heavy Vehicles, %	2	2	2	2	2	2
Mvmt Flow	9	105	164	64	37	5

Major/Minor	Major1	Major2	Minor2		
Conflicting Flow All	228	0	-	0	319
Stage 1	-	-	-	-	196
Stage 2	-	-	-	-	123
Critical Hdwy	4.12	-	-	-	6.42
Critical Hdwy Stg 1	-	-	-	-	5.42
Critical Hdwy Stg 2	-	-	-	-	5.42
Follow-up Hdwy	2.218	-	-	-	3.518
Pot Cap-1 Maneuver	1340	-	-	-	674
Stage 1	-	-	-	-	837
Stage 2	-	-	-	-	902
Platoon blocked, %		-	-	-	
Mov Cap-1 Maneuver	1340	-	-	-	669
Mov Cap-2 Maneuver	-	-	-	-	669
Stage 1	-	-	-	-	831
Stage 2	-	-	-	-	902

Approach	EB	WB	SB
HCM Control Delay, s	0.6	0	10.5
HCM LOS			B

Minor Lane/Major Mvmt	EBL	EBT	WBT	WBR	SBLn1	SBLn2
Capacity (veh/h)	1340	-	-	-	669	845
HCM Lane V/C Ratio	0.006	-	-	-	0.055	0.006
HCM Control Delay (s)	7.7	-	-	-	10.7	9.3
HCM Lane LOS	A	-	-	-	B	A
HCM 95th %tile Q(veh)	0	-	-	-	0.2	0

Intersection												
Int Delay, s/veh	4.9											
Movement	EBL	EBT	EBR	WBL	WBT	WBR	NBL	NBT	NBR	SBL	SBT	SBR
Lane Configurations		↔	↔		↔	↔	↔	↔		↔	↔	
Traffic Vol, veh/h	15	0	59	5	0	0	101	48	8	0	51	25
Future Vol, veh/h	15	0	59	5	0	0	101	48	8	0	51	25
Conflicting Peds, #/hr	0	0	0	0	0	0	0	0	0	0	0	0
Sign Control	Stop	Stop	Stop	Stop	Stop	Stop	Free	Free	Free	Free	Free	Free
RT Channelized	-	-	None	-	-	None	-	-	None	-	-	None
Storage Length	-	-	0	-	-	0	0	-	-	50	-	-
Veh in Median Storage, #	-	0	-	-	0	-	-	0	-	-	0	-
Grade, %	-	0	-	-	0	-	-	0	-	-	0	-
Peak Hour Factor	92	92	92	92	92	92	92	92	92	92	92	92
Heavy Vehicles, %	2	2	2	2	2	2	2	2	2	2	2	2
Mvmt Flow	16	0	64	5	0	0	110	52	9	0	55	27

Major/Minor	Minor2		Minor1		Major1			Major2				
Conflicting Flow All	346	350	69	378	359	57	82	0	0	61	0	0
Stage 1	69	69	-	277	277	-	-	-	-	-	-	-
Stage 2	277	281	-	101	82	-	-	-	-	-	-	-
Critical Hdwy	7.12	6.52	6.22	7.12	6.52	6.22	4.12	-	-	4.12	-	-
Critical Hdwy Stg 1	6.12	5.52	-	6.12	5.52	-	-	-	-	-	-	-
Critical Hdwy Stg 2	6.12	5.52	-	6.12	5.52	-	-	-	-	-	-	-
Follow-up Hdwy	3.518	4.018	3.318	3.518	4.018	3.318	2.218	-	-	2.218	-	-
Pot Cap-1 Maneuver	608	574	994	580	568	1009	1515	-	-	1542	-	-
Stage 1	941	837	-	729	681	-	-	-	-	-	-	-
Stage 2	729	678	-	905	827	-	-	-	-	-	-	-
Platoon blocked, %								-	-	-	-	-
Mov Cap-1 Maneuver	574	532	994	513	527	1009	1515	-	-	1542	-	-
Mov Cap-2 Maneuver	574	532	-	513	527	-	-	-	-	-	-	-
Stage 1	872	837	-	676	631	-	-	-	-	-	-	-
Stage 2	676	629	-	847	827	-	-	-	-	-	-	-

Approach	EB		WB		NB		SB	
HCM Control Delay, s	9.4		12.1		4.9		0	
HCM LOS	A		B					

Minor Lane/Major Mvmt	NBL	NBT	NBR	EBLn1	EBLn2	WBLn1	WBLn2	SBL	SBT	SBR
Capacity (veh/h)	1515	-	-	574	994	513	-	1542	-	-
HCM Lane V/C Ratio	0.072	-	-	0.028	0.065	0.011	-	-	-	-
HCM Control Delay (s)	7.6	-	-	11.5	8.9	12.1	0	0	-	-
HCM Lane LOS	A	-	-	B	A	B	A	A	-	-
HCM 95th %tile Q(veh)	0.2	-	-	0.1	0.2	0	-	0	-	-

Intersection						
Int Delay, s/veh	4.4					
Movement	EBT	EBR	WBL	WBT	NBL	NBR
Lane Configurations	↔		↔	↑	↔	↔
Traffic Vol, veh/h	53	0	92	63	0	53
Future Vol, veh/h	53	0	92	63	0	53
Conflicting Peds, #/hr	0	0	0	0	0	0
Sign Control	Free	Free	Free	Free	Stop	Stop
RT Channelized	-	None	-	None	-	None
Storage Length	-	-	50	-	0	0
Veh in Median Storage, #	0	-	-	0	0	-
Grade, %	0	-	-	0	0	-
Peak Hour Factor	92	92	92	92	92	92
Heavy Vehicles, %	2	2	2	2	2	2
Mvmt Flow	58	0	100	68	0	58

Major/Minor	Major1	Major2	Minor1			
Conflicting Flow All	0	0	58	0	326	58
Stage 1	-	-	-	-	58	-
Stage 2	-	-	-	-	268	-
Critical Hdwy	-	-	4.12	-	6.42	6.22
Critical Hdwy Stg 1	-	-	-	-	5.42	-
Critical Hdwy Stg 2	-	-	-	-	5.42	-
Follow-up Hdwy	-	-	2.218	-	3.518	3.318
Pot Cap-1 Maneuver	-	-	1546	-	668	1008
Stage 1	-	-	-	-	965	-
Stage 2	-	-	-	-	777	-
Platoon blocked, %	-	-	-	-	-	-
Mov Cap-1 Maneuver	-	-	1546	-	625	1008
Mov Cap-2 Maneuver	-	-	-	-	625	-
Stage 1	-	-	-	-	965	-
Stage 2	-	-	-	-	726	-

Approach	EB	WB	NB
HCM Control Delay, s	0	4.4	8.8
HCM LOS			A

Minor Lane/Major Mvmt	NBLn1	NBLn2	EBT	EBR	WBL	WBT
Capacity (veh/h)	-	1008	-	-	1546	-
HCM Lane V/C Ratio	-	0.057	-	-	0.065	-
HCM Control Delay (s)	0	8.8	-	-	7.5	-
HCM Lane LOS	A	A	-	-	A	-
HCM 95th %tile Q(veh)	-	0.2	-	-	0.2	-

Intersection						
Int Delay, s/veh	1.3					
Movement	EBT	EBR	WBL	WBT	NBL	NBR
Lane Configurations	↔		↔	↑	↔	↔
Traffic Vol, veh/h	102	4	33	153	2	17
Future Vol, veh/h	102	4	33	153	2	17
Conflicting Peds, #/hr	0	0	0	0	0	0
Sign Control	Free	Free	Free	Free	Stop	Stop
RT Channelized	-	None	-	None	-	None
Storage Length	-	-	50	-	0	0
Veh in Median Storage, #	0	-	-	0	0	-
Grade, %	0	-	-	0	0	-
Peak Hour Factor	92	92	92	92	92	92
Heavy Vehicles, %	2	2	2	2	2	2
Mvmt Flow	111	4	36	166	2	18

Major/Minor	Major1	Major2	Minor1		
Conflicting Flow All	0	0	115	0	351 113
Stage 1	-	-	-	-	113 -
Stage 2	-	-	-	-	238 -
Critical Hdwy	-	-	4.12	-	6.42 6.22
Critical Hdwy Stg 1	-	-	-	-	5.42 -
Critical Hdwy Stg 2	-	-	-	-	5.42 -
Follow-up Hdwy	-	-	2.218	-	3.518 3.318
Pot Cap-1 Maneuver	-	-	1474	-	646 940
Stage 1	-	-	-	-	912 -
Stage 2	-	-	-	-	802 -
Platoon blocked, %	-	-	-	-	-
Mov Cap-1 Maneuver	-	-	1474	-	630 940
Mov Cap-2 Maneuver	-	-	-	-	630 -
Stage 1	-	-	-	-	912 -
Stage 2	-	-	-	-	783 -

Approach	EB	WB	NB
HCM Control Delay, s	0	1.3	9.1
HCM LOS			A

Minor Lane/Major Mvmt	NBLn1	NBLn2	EBT	EBR	WBL	WBT
Capacity (veh/h)	630	940	-	-	1474	-
HCM Lane V/C Ratio	0.003	0.02	-	-	0.024	-
HCM Control Delay (s)	10.7	8.9	-	-	7.5	-
HCM Lane LOS	B	A	-	-	A	-
HCM 95th %tile Q(veh)	0	0.1	-	-	0.1	-

Intersection						
Int Delay, s/veh	6.2					
Movement	EBT	EBR	WBL	WBT	NBL	NBR
Lane Configurations	↔		↔	↑	↔	↔
Traffic Vol, veh/h	85	34	270	150	36	180
Future Vol, veh/h	85	34	270	150	36	180
Conflicting Peds, #/hr	0	0	0	0	0	0
Sign Control	Free	Free	Free	Free	Stop	Stop
RT Channelized	-	None	-	None	-	None
Storage Length	-	-	100	-	0	0
Veh in Median Storage, #	0	-	-	0	0	-
Grade, %	0	-	-	0	0	-
Peak Hour Factor	92	92	92	92	92	92
Heavy Vehicles, %	2	2	2	2	2	2
Mvmt Flow	92	37	293	163	39	196

Major/Minor	Major1	Major2	Minor1		
Conflicting Flow All	0	0	129	0	860 111
Stage 1	-	-	-	-	111 -
Stage 2	-	-	-	-	749 -
Critical Hdwy	-	-	4.12	-	6.42 6.22
Critical Hdwy Stg 1	-	-	-	-	5.42 -
Critical Hdwy Stg 2	-	-	-	-	5.42 -
Follow-up Hdwy	-	-	2.218	-	3.518 3.318
Pot Cap-1 Maneuver	-	-	1457	-	326 942
Stage 1	-	-	-	-	914 -
Stage 2	-	-	-	-	467 -
Platoon blocked, %	-	-	-	-	-
Mov Cap-1 Maneuver	-	-	1457	-	260 942
Mov Cap-2 Maneuver	-	-	-	-	260 -
Stage 1	-	-	-	-	914 -
Stage 2	-	-	-	-	373 -

Approach	EB	WB	NB
HCM Control Delay, s	0	5.2	11.7
HCM LOS			B

Minor Lane/Major Mvmt	NBLn1	NBLn2	EBT	EBR	WBL	WBT
Capacity (veh/h)	260	942	-	-	1457	-
HCM Lane V/C Ratio	0.151	0.208	-	-	0.201	-
HCM Control Delay (s)	21.3	9.8	-	-	8.1	-
HCM Lane LOS	C	A	-	-	A	-
HCM 95th %tile Q(veh)	0.5	0.8	-	-	0.8	-

Intersection						
Int Delay, s/veh	1					
Movement	EBL	EBR	NBL	NBT	SBT	SBR
Lane Configurations		↗		↕↕	↕↕	↗
Traffic Vol, veh/h	0	144	0	922	721	34
Future Vol, veh/h	0	144	0	922	721	34
Conflicting Peds, #/hr	0	0	0	0	0	0
Sign Control	Stop	Stop	Free	Free	Free	Free
RT Channelized	-	None	-	None	-	None
Storage Length	-	0	-	-	-	100
Veh in Median Storage, #	0	-	-	0	0	-
Grade, %	0	-	-	0	0	-
Peak Hour Factor	92	92	92	92	92	92
Heavy Vehicles, %	2	2	2	2	2	2
Mvmt Flow	0	157	0	1002	784	37

Major/Minor	Minor2	Major1	Major2
Conflicting Flow All	-	392	0
Stage 1	-	-	-
Stage 2	-	-	-
Critical Hdwy	-	6.94	-
Critical Hdwy Stg 1	-	-	-
Critical Hdwy Stg 2	-	-	-
Follow-up Hdwy	-	3.32	-
Pot Cap-1 Maneuver	0	607	0
Stage 1	0	-	0
Stage 2	0	-	0
Platoon blocked, %			-
Mov Cap-1 Maneuver	-	607	-
Mov Cap-2 Maneuver	-	-	-
Stage 1	-	-	-
Stage 2	-	-	-

Approach	EB	NB	SB
HCM Control Delay, s	13	0	0
HCM LOS	B		

Minor Lane/Major Mvmt	NBT	EBLn1	SBT	SBR
Capacity (veh/h)	-	607	-	-
HCM Lane V/C Ratio	-	0.258	-	-
HCM Control Delay (s)	-	13	-	-
HCM Lane LOS	-	B	-	-
HCM 95th %tile Q(veh)	-	1	-	-

Appendix D

Internal Capture Worksheets

NCHRP 684 Internal Trip Capture Estimation Tool					
Project Name:	Heritage at Dalia Ranch			Organization:	Mizuta Traffic
Project Location:	Imperial, CA			Performed By:	MTC
Scenario Description:	n/a			Date:	17-Nov
Analysis Year:	n/a			Checked By:	MTC
Analysis Period:	AM Street Peak Hour			Date:	17-Nov

Table 1-A: Base Vehicle-Trip Generation Estimates (Single-Use Site Estimate)						
Land Use	Development Data (For Information Only)			Estimated Vehicle-Trips ³		
	ITE LUCs ¹	Quantity	Units	Total	Entering	Exiting
Office				93	73	20
Retail				77	47	30
Restaurant				193	99	94
Cinema/Entertainment				0		
Residential				198	50	148
Hotel				0		
All Other Land Uses ²				321	172	149
				882	441	441

Table 2-A: Mode Split and Vehicle Occupancy Estimates						
Land Use	Entering Trips			Exiting Trips		
	Veh. Occ. ⁴	% Transit	% Non-Motorized	Veh. Occ. ⁴	% Transit	% Non-Motorized
Office						
Retail						
Restaurant						
Cinema/Entertainment						
Residential						
Hotel						
All Other Land Uses ²						

Table 3-A: Average Land Use Interchange Distances (Feet Walking Distance)						
Origin (From)	Destination (To)					
	Office	Retail	Restaurant	Cinema/Entertainment	Residential	Hotel
Office						
Retail						
Restaurant						
Cinema/Entertainment						
Residential						
Hotel						

Table 4-A: Internal Person-Trip Origin-Destination Matrix*						
Origin (From)	Destination (To)					
	Office	Retail	Restaurant	Cinema/Entertainment	Residential	Hotel
Office		6	13	0	0	0
Retail	3		4	0	1	0
Restaurant	10	4		0	3	0
Cinema/Entertainment	0	0	0		0	0
Residential	2	1	20	0		0
Hotel	0	0	0	0	0	

Table 5-A: Computations Summary			
	Total	Entering	Exiting
All Person-Trips	882	441	441
Internal Capture Percentage	15%	15%	15%
External Vehicle-Trips ⁵	748	374	374
External Transit-Trips ⁶	0	0	0
External Non-Motorized Trips ⁶	0	0	0

Table 6-A: Internal Trip Capture Percentages by Land Use		
Land Use	Entering Trips	Exiting Trips
Office	21%	95%
Retail	23%	27%
Restaurant	37%	18%
Cinema/Entertainment	N/A	N/A
Residential	8%	16%
Hotel	N/A	N/A

¹Land Use Codes (LUCs) from *Trip Generation Manual*, published by the Institute of Transportation Engineers.

²Total estimate for all other land uses at mixed-use development site is not subject to internal trip capture computations in this estimator.

³Enter trips assuming no transit or non-motorized trips (as assumed in ITE *Trip Generation Manual*).

⁴Enter vehicle occupancy assumed in Table 1-A vehicle trips. If vehicle occupancy changes for proposed mixed-use project, manual adjustments must be made to Tables 5-A, 9-A (O and D). Enter transit, non-motorized percentages that will result with proposed mixed-use project complete.

⁵Vehicle-trips computed using the mode split and vehicle occupancy values provided in Table 2-A.

⁶Person-Trips

*Indicates computation that has been rounded to the nearest whole number.

Estimation Tool Developed by the Texas A&M Transportation Institute - Version 2013.1

Project Name:	Heritage at Dalia Ranch
Analysis Period:	AM Street Peak Hour

Land Use	Table 7-A (D): Entering Trips			Table 7-A (O): Exiting Trips		
	Veh. Occ.	Vehicle-Trips	Person-Trips*	Veh. Occ.	Vehicle-Trips	Person-Trips*
Office	1.00	73	73	1.00	20	20
Retail	1.00	47	47	1.00	30	30
Restaurant	1.00	99	99	1.00	94	94
Cinema/Entertainment	1.00	0	0	1.00	0	0
Residential	1.00	50	50	1.00	148	148
Hotel	1.00	0	0	1.00	0	0

Origin (From)	Destination (To)					
	Office	Retail	Restaurant	Cinema/Entertainment	Residential	Hotel
Office		6	13	0	0	0
Retail	9		4	0	4	0
Restaurant	29	13		0	4	3
Cinema/Entertainment	0	0	0		0	0
Residential	3	1	30	0		0
Hotel	0	0	0	0	0	

Origin (From)	Destination (To)					
	Office	Retail	Restaurant	Cinema/Entertainment	Residential	Hotel
Office		15	23	0	0	0
Retail	3		50	0	1	0
Restaurant	10	4		0	3	0
Cinema/Entertainment	0	0	0		0	0
Residential	2	8	20	0		0
Hotel	2	2	6	0	0	

Destination Land Use	Person-Trip Estimates			External Trips by Mode*		
	Internal	External	Total	Vehicles ¹	Transit ²	Non-Motorized ²
Office	15	58	73	58	0	0
Retail	11	36	47	36	0	0
Restaurant	37	62	99	62	0	0
Cinema/Entertainment	0	0	0	0	0	0
Residential	4	46	50	46	0	0
Hotel	0	0	0	0	0	0
All Other Land Uses ³	0	172	172	172	0	0

Origin Land Use	Person-Trip Estimates			External Trips by Mode*		
	Internal	External	Total	Vehicles ¹	Transit ²	Non-Motorized ²
Office	19	1	20	1	0	0
Retail	8	22	30	22	0	0
Restaurant	17	77	94	77	0	0
Cinema/Entertainment	0	0	0	0	0	0
Residential	23	125	148	125	0	0
Hotel	0	0	0	0	0	0
All Other Land Uses ³	0	149	149	149	0	0

¹Vehicle-trips computed using the mode split and vehicle occupancy values provided in Table 2-A
²Person-Trips
³Total estimate for all other land uses at mixed-use development site is not subject to internal trip capture computations in this estimator
*Indicates computation that has been rounded to the nearest whole number.

NCHRP 684 Internal Trip Capture Estimation Tool			
Project Name:	Heritage at Dalia Ranch	Organization:	Mizuta Traffic
Project Location:	Imperial, CA	Performed By:	MTC
Scenario Description:	n/a	Date:	17-Nov
Analysis Year:	n/a	Checked By:	MTC
Analysis Period:	PM Street Peak Hour	Date:	17-Nov

Table 1-P: Base Vehicle-Trip Generation Estimates (Single-Use Site Estimate)						
Land Use	Development Data (For Information Only)			Estimated Vehicle-Trips ³		
	ITE LUCs ¹	Quantity	Units	Total	Entering	Exiting
Office				115	33	82
Retail				134	65	69
Restaurant				157	82	75
Cinema/Entertainment				0		
Residential				264	168	96
Hotel				0		
All Other Land Uses ²				468	240	228
				1,138	588	550

Table 2-P: Mode Split and Vehicle Occupancy Estimates						
Land Use	Entering Trips			Exiting Trips		
	Veh. Occ. ⁴	% Transit	% Non-Motorized	Veh. Occ. ⁴	% Transit	% Non-Motorized
Office						
Retail						
Restaurant						
Cinema/Entertainment						
Residential						
Hotel						
All Other Land Uses ²						

Table 3-P: Average Land Use Interchange Distances (Feet Walking Distance)						
Origin (From)	Destination (To)					
	Office	Retail	Restaurant	Cinema/Entertainment	Residential	Hotel
Office						
Retail						
Restaurant						
Cinema/Entertainment						
Residential						
Hotel						

Table 4-P: Internal Person-Trip Origin-Destination Matrix*						
Origin (From)	Destination (To)					
	Office	Retail	Restaurant	Cinema/Entertainment	Residential	Hotel
Office		5	2	0	2	0
Retail	1		20	0	18	0
Restaurant	2	31		0	14	0
Cinema/Entertainment	0	0	0		0	0
Residential	4	7	11	0		0
Hotel	0	0	0	0	0	

Table 5-P: Computations Summary			
	Total	Entering	Exiting
All Person-Trips	1,138	588	550
Internal Capture Percentage	21%	20%	21%
External Vehicle-Trips ⁵	904	471	433
External Transit-Trips ⁶	0	0	0
External Non-Motorized Trips ⁶	0	0	0

Table 6-P: Internal Trip Capture Percentages by Land Use		
Land Use	Entering Trips	Exiting Trips
Office	21%	11%
Retail	66%	57%
Restaurant	40%	63%
Cinema/Entertainment	N/A	N/A
Residential	20%	23%
Hotel	N/A	N/A

¹Land Use Codes (LUCs) from *Trip Generation Manual*, published by the Institute of Transportation Engineers.

²Total estimate for all other land uses at mixed-use development site is not subject to internal trip capture computations in this estimator.

³Enter trips assuming no transit or non-motorized trips (as assumed in ITE *Trip Generation Manual*).

⁴Enter vehicle occupancy assumed in Table 1-P vehicle trips. If vehicle occupancy changes for proposed mixed-use project, manual adjustments must be made.

⁵Vehicle-trips computed using the mode split and vehicle occupancy values provided in Table 2-P.

⁶Person-Trips

*Indicates computation that has been rounded to the nearest whole number.

Estimation Tool Developed by the Texas A&M Transportation Institute - Version 2013.1

Project Name:	Heritage at Dalia Ranch
Analysis Period:	PM Street Peak Hour

Table 7-P: Conversion of Vehicle-Trip Ends to Person-Trip Ends						
Land Use	Table 7-P (D): Entering Trips			Table 7-P (O): Exiting Trips		
	Veh. Occ.	Vehicle-Trips	Person-Trips*	Veh. Occ.	Vehicle-Trips	Person-Trips*
Office	1.00	33	33	1.00	82	82
Retail	1.00	65	65	1.00	69	69
Restaurant	1.00	82	82	1.00	75	75
Cinema/Entertainment	1.00	0	0	1.00	0	0
Residential	1.00	168	168	1.00	96	96
Hotel	1.00	0	0	1.00	0	0

Table 8-P (O): Internal Person-Trip Origin-Destination Matrix (Computed at Origin)						
Origin (From)	Destination (To)					
	Office	Retail	Restaurant	Cinema/Entertainment	Residential	Hotel
Office		16	3	0	2	0
Retail	1		20	3	18	3
Restaurant	2	31		6	14	5
Cinema/Entertainment	0	0	0		0	0
Residential	4	40	20	0		3
Hotel	0	0	0	0	0	

Table 8-P (D): Internal Person-Trip Origin-Destination Matrix (Computed at Destination)						
Origin (From)	Destination (To)					
	Office	Retail	Restaurant	Cinema/Entertainment	Residential	Hotel
Office		5	2	0	7	0
Retail	10		24	0	77	0
Restaurant	10	33		0	27	0
Cinema/Entertainment	2	3	2		7	0
Residential	19	7	11	0		0
Hotel	0	1	4	0	0	

Table 9-P (D): Internal and External Trips Summary (Entering Trips)						
Destination Land Use	Person-Trip Estimates			External Trips by Mode*		
	Internal	External	Total	Vehicles ¹	Transit ²	Non-Motorized ²
Office	7	26	33	26	0	0
Retail	43	22	65	22	0	0
Restaurant	33	49	82	49	0	0
Cinema/Entertainment	0	0	0	0	0	0
Residential	34	134	168	134	0	0
Hotel	0	0	0	0	0	0
All Other Land Uses ³	0	240	240	240	0	0

Table 9-P (O): Internal and External Trips Summary (Exiting Trips)						
Origin Land Use	Person-Trip Estimates			External Trips by Mode*		
	Internal	External	Total	Vehicles ¹	Transit ²	Non-Motorized ²
Office	9	73	82	73	0	0
Retail	39	30	69	30	0	0
Restaurant	47	28	75	28	0	0
Cinema/Entertainment	0	0	0	0	0	0
Residential	22	74	96	74	0	0
Hotel	0	0	0	0	0	0
All Other Land Uses ³	0	228	228	228	0	0

¹Vehicle-trips computed using the mode split and vehicle occupancy values provided in Table 2-P

²Person-Trips

³Total estimate for all other land uses at mixed-use development site is not subject to internal trip capture computations in this estimator

*Indicates computation that has been rounded to the nearest whole number.

Appendix E

SCAG Profile of Imperial County Report Excerpts

Profile of Imperial County

Southern California Association of Governments (SCAG) Regional Council includes 69 districts which represent 191 cities and 6 counties in the SCAG region



LOCAL PROFILES REPORT 2019

This profile report was prepared by the Southern California Association of Governments and shared with Imperial County. SCAG provides local governments with a variety of benefits and services including, for example, data and information, GIS training, planning and technical assistance, and sustainability planning grants.

II. POPULATION

Population Growth

Population: 2000 - 2018

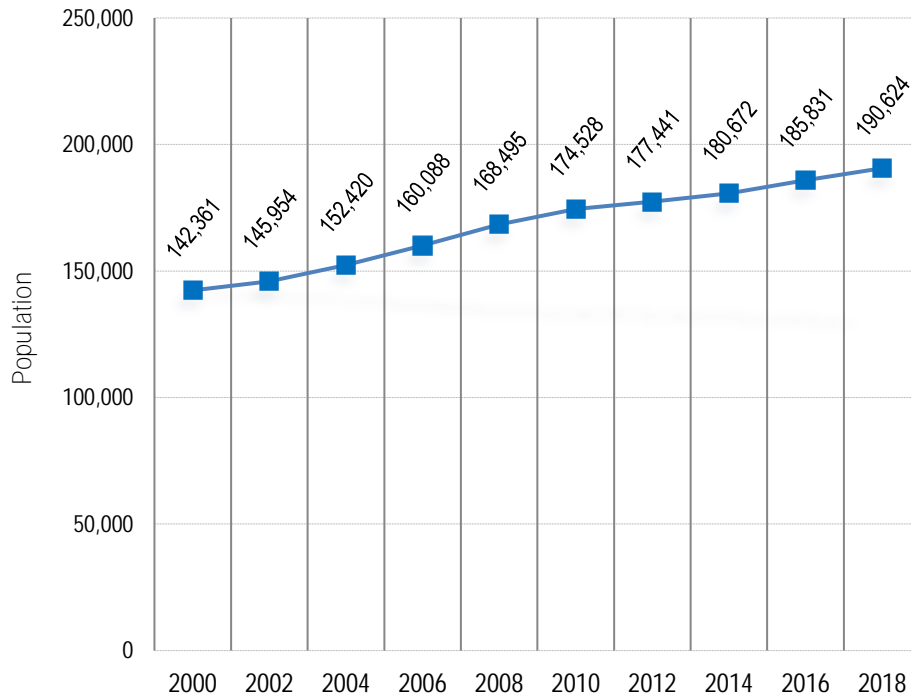

Source: California Department of Finance, E-5, 2000-2018

- Between 2000 and 2018, the total population of Imperial County increased by 48,263 to 190,624.
- During this 18-year period, the county’s population growth rate of 33.9 percent was higher than the SCAG Region rate of 15.9 percent.
- 1.0 percent of the total population of SCAG Region is in Imperial County.
- Population values for 2000 and 2010 are from the U.S. Decennial Census.
- Values for other years are estimates by the California Department of Finance.



City of Imperial
**Initial Study/
Environmental Checklist**

1. **Project Title:** Morningstar Subdivision Zone Change R-1 to R-A
 2. **Lead Agency:** City of Imperial
420 South Imperial Avenue
Imperial, CA 92251
Contact: Othon Mora
(760) 355-1152
 3. **Project Sponsor:** Ray Roben
115 N Imperial Ave., Suite D
 4. **Project Location:** APN: 063-010-089
 5. **Project Description:** Change of zoning designation from R-1 (single-family Residential) to R-A (Residential Apartment) and proposed New Multifamily Residential apartment project.
 6. **General Plan Designation:** **Existing:** Residential Low Medium Density
Proposed: Residential High Density
 7. **Zoning:** **Existing:** R-1 (Single-Family Residential)
Proposed: R-A (Residential Apartment)
 8. **Surrounding Land Uses and Setting:** **North:** Residential Uses
South: Commercial Uses
East: Residential Uses
West: Residential Uses
- Other Agencies whose approval is required: (e.g., permits, financing approval, or participation agreement)**
- a) None

ENVIRONMENTAL FACTORS POTENTIALLY AFFECTED:

The environmental factors checked below would be potentially affected by this project, involving at least one impact that is a “Potentially Significant Impact” as indicated by the checklist on the following pages.

Aesthetics	Agriculture & Forestry Resources	Air Quality
Biological Resources	Cultural Resources	Energy
Geology/Soils	Greenhouse Gas Emissions	Hazards & Hazardous Materials
Hydrology/Water Quality	Land Use Planning	Mineral Resources
Noise	Population/Housing	Public Services
Recreation	Transportation	Tribal Cultural Resources
Utilities/Service System	Wildfire	Mandatory Findings of Significance

ENVIRONMENTAL ASSESSMENT COMMITTEE DETERMINATION:

On the basis of the attached Initial Study, the City of Imperial Environmental Review Committee finds that:

Categorically Exempt under section of the California Environmental Quality Act:	
The proposed project could not have a significant effect on the environment, and a NEGATIVE DECLARATION will be prepared.	X
The proposed project could have a significant effect on the environment; there will not be a significant effect in this case because the mitigation measures described on an attached sheet have been added to the project. A MITIGATED NEGATIVE DECLARATION will be prepared.	
The proposed project MAY have a significant effect(s) on the environment and an ENVIRONMENTAL IMPACT REPORT is required	
The proposed project MAY have a significant effect(s) on the environment, but at least one effect (1) has been adequately analyzed in an earlier document pursuant to applicable legal standards, and (2) has been addressed by mitigation measures based on the earlier analysis as described on attached sheets, if the effect is a “Potentially Significant Impact” or “Potentially Significant Unless Mitigated.” A FOCUSED ENVIRONMENTAL IMPACT REPORT is required, but it must analyze only the effects that remain to be addressed.	
Although the proposed project could have a significant effect on the environment, there WILL NOT be a significant effect in this case because all potentially significant effects (1) have been analyzed in an earlier EIR pursuant to applicable standards and (2) have been avoided or mitigated pursuant to that earlier EIR, including revisions or mitigation measures that are imposed upon the proposed project. No further action is required.	X

 Othon Mora, CBO, MCM
 Community Development Director

 Date

EVALUATION OF ENVIRONMENTAL IMPACTS:

- 1) A brief explanation is required for all answers except “No Impact” answers that are adequately supported by the information sources a lead agency cites in the parentheses following each question. A “No Impact”

answer is adequately supported if the referenced information sources show that the impact simply does not apply to projects like the one involved (e. g. the project falls outside a fault rupture zone). A “No Impact” answer should be explained where it is based on project-specific factors as well as general standards (e. g. the project will not expose sensitive receptors to pollutants, based on a project-specific screening analysis).

- 2) All answers must take account of the whole action involved, including off-site as well as on-site, cumulative as well as project-level, indirect as well as direct, and construction as well as operational impacts.
- 3) Once the lead agency has determined that a particular physical impact may occur then the checklist answers must indicate whether the impact is potentially significant, less than significant with mitigation, or less than significant. “Potentially Significant Impact” is appropriate if there is substantial evidence that an effect is significant. If there are one or more “Potentially Significant Impact” entries when the determination is made, an EIR is required.
- 4) “Negative Declaration: Less Than Significant With Mitigation Incorporated” applies where the incorporation of mitigation measures has reduced an effect from “Potentially Significant Impact” to a “Less than Significant Impact.” The lead agency must describe the mitigation measures, and briefly explain how they reduce the effect to a less than significant level (mitigation measures from Section 17, “Earlier Analysis,” may be cross-referenced).
- 5) Earlier analysis may be used where, pursuant to the tiering, program EIR, or other CEQA process, an effect has been adequately analyzed in an earlier EIR or negative declaration. Section 15063(c)(3)(D). In this case, a brief discussion should identify the follow:
 - a. Earlier Analysis Used. Identify and state where they are available for review.
 - b. Impacts Adequately Addressed. Identify which effects from the above checklist were within the scope of and adequately analyzed in an earlier document pursuant to applicable legal standards, and state whether such effects were addressed by mitigation measures based on the earlier analysis.
 - c. Mitigation Measures. For effects that are “Less than Significant with Mitigation Measures Incorporated,” describe the mitigation measures, which were incorporated or refined from the earlier document and the extent to which they address site-specific conditions for the project.

Authority: Public Resources Code Sections 21083 and 21087. Reference: Public Resources Code Sections 21080(c), 21080.1, 21080.3, 21082.1, 21083, 21083.3, 21093, 21094, 21151; *Sundstrom v. County of Mendocino*, 202 Cal. App. 3d 296 (1988); *Leonoff v. Monterey Board of Supervisors*, 222 Cal. App. 3d 1337 (1990).

- 6) Lead agencies are encouraged to incorporate into the checklist references to information sources for potential impacts (e.g. general plans, zoning ordinances). Reference to a previously prepared or outside document should, where appropriate, include a reference to the page or pages where the statement is substantiated.
- 7) Supporting Information Sources: A source list should be attached, and other sources used or individuals contacted should be cited in the discussion.

I. AESTHETICS – Would the project:				
	Potentially Significant Issues	Potentially Significant Unless Mitigation Incorporated	Less Than Significant Impact	No Impact
a)	Have a substantially adverse affect on a scenic vista or scenic highway?			X
b)	Substantially damage scenic resources, including, but not limited to, trees, rock outcroppings, and historic buildings within a state scenic highway?			X
c)	Substantially degrade the existing visual character or quality of the site and its surroundings?			X
d)	Create a new source of substantial light or glare, which would adversely affect day or nighttime views in the area?			X

Background

The project will not have an impact on scenic vistas. The project will actual be an infill project on parcels that are currently vacant and located within an urbanized developed residential area.

Impact Discussion

- a) **No Impact.** The proposed project would not have an effect on scenic vista. It is to be located on a currently vacant lot.
- b) **No Impact.** The proposed zone change would not damage scenic resources. The lot is vacant and not considered to have any historic value.
- c) **No Impact.** The proposed project location resides amongst various vacant lots and would enhance the quality and character of the surrounding residential uses/zones via “infill”.
- d) **No Impact.** The proposed future use would be for multifamily housing. The light or glare generated will not have an adverse effect on the day or nighttime views. If and when in the future a multifamily project is applied for, the increase in density will create new sources of light and glare resulting from the addition of street lights and lighting from the additional homes. The City of Imperial Standards and Specifications requires the installation of low profile exterior lighting, directed away from adjacent properties, and as such, the impact of off-site glare and adverse light intrusion will be less than significant.

II. AGRICULTURE AND FORESTRY RESOURCES – Would the project:				
	Potentially Significant Issues	Potentially Significant Unless Mitigation Incorporated	Less Than Significant Impact	No Impact
a)	Convert Prime Farmland, Unique Farmland, or Farmland of State-wide Importance, as shown on maps prepared pursuant to the Farmland Mapping and Monitoring Program of the California Resources Agency, to non-agricultural use?			X
b)	Conflict with existing zoning for agricultural use, or a Williamson Act contract?			X
c)	Conflict with existing zoning for, or cause rezoning of, forest land (as defined in Public Resources Code section 4526). Or timberland zoned Timberland Production (as defined by Government Code Section 51104(g))?			X
d)	Result in the loss of forest land or conversion of forest land to non-forest land?			X
e)	Involve other changes in the existing environment which, due to their location of nature, could result in conversion of Farmland, to nonagricultural use or conversion of forest land to non-forest use?			X

Background

The proposed project is to be developed on vacant residentially zoned parcels within an already urbanized area. The project will not have any impact on agricultural uses.

Impact Discussion

- a) **No Impact.** The parcels are currently vacant and zoned R-1 (Residential Single Family). According to the Imperial County Important Farmland 2016 Map, the project site is listed as other lands, thus the proposed project will not convert any type of farmland to non-agricultural use; therefore, no impact is expected.
- b) **No Impact.** The proposed project site is in the midst of existing residences (enclave) and the rezoning of this parcel would not appear to conflict with the existing zoning. There is no Williamson Act land contract on the project site, so the project would not conflict with the Williamson Act land contract. Therefore, no impacts are anticipated.
- c) **No Impact.** The project will have no impact on forest land. Currently a vacant lot zoned R-1 (Residential Single Family). As mentioned above, the subject property is not zoned for forest land and the General Plan Land Use Map designates this site as "Residential" and the proposed residential apartments zone change will not conflict with existing zoning or cause rezoning of forest land, timberland or timberland zoned Timberland Production. Therefore, no impact is expected.
- d) **No Impact.** The proposed zone change and project will not result in the loss of forest land. The parcel is currently zoned R-1 (Single-Family Residential). As explained under item c) above, the proposed zone change and will not result in the loss of forest land or conversion of forest land to non-forest use. Therefore, no impact is expected.
- e) **No Impact.** The proposed zone change will not result or influence the conversion of farmlands, forests or agricultural uses to other uses.

<i>III. AIR QUALITY</i> – Would the project:				
	Potentially Significant Issues	Potentially Significant Unless Mitigation Incorporated	Less Than Significant Impact	No Impact
a) Conflict with or obstruct implementation of the applicable air quality plan?				X
b) Violate any air quality standard or contribute substantially to an existing or projected air quality violation?				X
c) Result in a cumulatively considerable net increase of any criteria pollutant for which the project region is non-attainment under an applicable federal or state ambient air quality standard (including releasing emissions that exceed quantitative thresholds for ozone precursors)?				X
d) Expose sensitive receptors to substantial pollutant concentrations?				X
e) Create objectionable odors affecting a substantial number of people?				X

Background

The zone change will not have a negative impact on the air quality. The proposed site is located within the Salton Sea Air Basin and is under the jurisdiction of the Imperial County Air Pollution Control District (ICAPCD). The Imperial Valley has been designated as a “non-attainment” area with respect to State Standards for particulate matter (PM10) and ozone (smog). The ICAPCD recommends that construction projects in the Imperial Valley follow the standard and discretionary mitigation measures outlined in Section VII of the ICAPCD CEQA Air Quality Handbook in order to minimize PM10 and emissions generation on-site. The ICAPCD also suggests that projects incorporate street tree planting and other landscaping along interior streets and project boundaries as these green spaces act as filters for dust and other pollutants.

The proposed zone change will not generate dust but when there is an official apartment project it is likely to generate dust and other forms of pollutants during Project construction and long-term project emissions will result from traffic generated by the residential development, in the future. Adjacent residences are considered sensitive receptors and may be negatively affected from these short and long-term emissions. The APCD considers a project to be mitigated to a level of insignificance if the project incorporates all feasible mitigation measures listed in Section VII of the handbook and/or exhausts all CEQA options for mitigation subject to CEQA Guidelines §15370.

Impact Discussion

- a) **No Impact.** The proposed zone change will have no impact on any applicable air quality plan. The proposed zone change and any future development shall conform to the requirement of the Imperial County Air Pollution Control District (ICAPCD). Therefore, less than significant impacts are anticipated.
- b) **No Impact.** As explained in Item a) above, the proposed project is a zone change will not result in a cumulative net increase of any criteria pollutant for which the project is non-attainment. The project will not violate any air quality standards or contribute substantially to an existing or projected air quality violation. Therefore, no impacts are anticipated.
- c) **No Impact.** The proposed zone change will not result in any increase of any criteria pollutant for which the region is in non-attainment. The project proposes a zone change with no proposed change to the use and

does not anticipate exposing receptors to substantial pollutants concentrations. Therefore, no impacts are anticipated.

- d) **No Impact.** The proposed zone change will not have an impact nor contribute to pollution. The project proposes a zone change and no proposed change to the current use (vacant lot) and does not anticipate in creating more objectionable odors that already exists with the adherence of ICAPCD requirements.
- e) **No Impact.** The proposed zone change should not create objectionable odors that could potentially effect a substantial number of people. Therefore, no impacts are anticipated.

<i>IV. BIOLOGICAL RESOURCES</i> – Would the project:				
	Potentially Significant Issues	Potentially Significant Unless Mitigation Incorporated	Less Than Significant Impact	No Impact
a)	Have a substantial adverse effect, either directly or through habitat modifications, on any species identified as a candidate, sensitive, or special status species in local or regional plans, policies, or by the California Department of Fish and Game or U.S. Fish and Wildlife Service?			X
b)	Have a substantial adverse effect on any riparian habitat or other sensitive natural community identified in local or regional plans, policies, regulations, or by the California Department of Fish and Game or U.S. Fish and Wildlife Service?			X
c)	Have a substantial adverse effect on federally protected wetlands as defined by Section 404 of the Clean Water Act (including, but not limited to, marsh, vernal pool, coastal, etc.) through direct removal, filling, hydrological interruption, or other means?			X
d)	Interfere substantially with the movement of any resident or migratory fish or wildlife species or with established native resident or migratory wildlife corridors, or impede the use of native wildlife nursery sites?			X
e)	Conflict with any local policies or ordinances protecting biological resources, such as a tree preservation policy or ordinance?			X
f)	Conflict with the provisions of an adopted Habitat Conservation Plan, Natural Community Conservation Plan, or other approved local, regional, or state habitat conservation plan?			X

Background

The proposed zone change is for a vacant parcel within an urbanized area that is zoned for Residential uses.

Impact Discussion

- a) **No Impact.** The proposed project site is located within disturbed land and does not appear to have a substantially adverse effect, either directly or through habitat modification, or any species identified as a candidate, sensitive or special status species in local or regional plan, policies, or regulation, or by the Departments of Fish and Wildlife. Therefore, no impacts are anticipated.

- b) **No Impact.** The proposed zone change is for a vacant parcel that is currently zoned R-1(Residential Single-Family). As mentioned under item a) above, the project site is located within disturbed land and does not appear to have a substantial effect on any riparian habitat or other sensitive natural community identified in local or regional plan, policies, and regulations or by the Departments of Fish and Wildlife. Therefore, no impacts are anticipated.
- c) **No Impact.** There are not any wetlands within the vicinity of the proposed zone change location. As explained in Item a) above, the project proposes a zone change on land that is currently zoned for residential uses and has already been disturbed, will not cause a substantial adverse effect on federal protected wetlands as defined by Section 404 of the Clean Water Act (including but not limited to, marsh, vernal pool, coastal, etc.) through direct removal, filling, hydrological interruption, or other means. Therefore, no impacts are anticipated.
- d) **No Impact.** The zone change is proposed for a vacant parcel that is zoned R-1 and surrounded by residential zoning and uses. As mentioned under Item a) above, the proposed zone change will not interfere substantially with the movement of any residential or migratory fish or wildlife species or with established resident or migratory wildlife, corridors or impede the use of native wildlife nursery sites. Therefore, no impacts are anticipated.
- e) **No Impact.** The proposed zone change will not conflict with any local policies or ordinances protecting biological resources, such as a tree preservation policy or ordinance. Therefore, no impact is expected.
- f) **No Impact.** The zone change will not conflict with the provisions of an adopted Habitat Conservation Plan, Natural Community Conservation Plan, or other approved local, regional, or state habitat conservation plan.

V. CULTURAL RESOURCES – Would the project:				
	Potentially Significant Issues	Potentially Significant Unless Mitigation Incorporated	Less Than Significant Impact	No Impact
a) Cause a substantial adverse change in the significance of a historical resource as defined in Section 15064.5?				X
b) Cause a substantial adverse change in the significance of an archaeological resource pursuant to Section 15064.5?				X
c) Directly or indirectly destroy a unique paleontological resource or site or unique geologic feature?				X
d) Disturb any human remains, including those interred outside of formal cemeteries?				X

Background

The proposed zone change is to be located on a vacant parcel that is not tied to nor has been identified by the State of California to have any cultural value or history. The project will not have an adverse change in the significance of a historical resource as defined in §15064.5.

Impact Discussion

- a) **No Impact.** The project will not cause adverse change with historical resources. It is to be located on a vacant lot. The project will not have an adverse change in the significance of a historical resource as defined in §15064.5.
- b) **No Impact.** The project will not cause adverse change with archaeological resources. It is to be located on a vacant lot on disturbed land and is not expected to directly or indirectly destroy a unique paleontological resource or unique geologic feature. Therefore, any impacts should be less than significant.
- c) **No Impact.** The project will not directly or indirectly destroy a unique paleontological resource or site or unique geologic feature on disturbed land and is not expected to directly or indirectly destroy a unique paleontological resource or unique geologic feature.
- d) **No Impact.** The project will not have an impact on human remains. As mentioned under Item a) above, the project site is located on disturbed land and is not expected to result in the disturbance of any human remains, including those interred outside of dedicated cemeteries. Therefore, any impact would be less than significant.

<i>VI. ENERGY – Would the project:</i>				
	Potentially Significant Issues	Potentially Significant Unless Mitigation Incorporated	Less Than Significant Impact	No Impact
a) Result in potentially significant environmental impact due to wasteful, inefficient, or unnecessary consumption of energy resources, during project construction or operation?				X
b) Conflict with or obstruct a state or local plan for renewable energy or energy efficiency?				X

Background

The zone change will not create unnecessary consumption of energy.

Impact Discussion

- a) **No Impact.** Will not result in potentially significant environmental impact due to wasteful, inefficient, or unnecessary consumption of energy resources, during project construction or operation.
- b) **No Impact.** Will not conflict with or obstruct a state or local plan for renewable energy or energy efficiency.

VII. GEOLOGY AND SOILS – Would the project:				
	Potentially Significant Issues	Potentially Significant Unless Mitigation Incorporated	Less Than Significant Impact	No Impact
a) Expose people or structures to potential substantial adverse effects, including risk of loss, injury, or death involving:				
1) Rupture of a known earthquake fault, as delineated on the most recent Alquist-Priolo Earthquake Fault Zoning Map issued by the State Geologist for the area or based on other substantial evidence of a known fault? Refer to Division of Mines and Geology Special Publication 42.				X
2) Strong seismic ground shaking?				X
3) Seismic-related ground failure, including liquefaction?				X
4) Landslides?				X
b) Result in substantial soil erosion or the loss of topsoil?				X
c) Be located on a geologic unit or soil that is unstable or that would become unstable as a result of the project, and potentially result in on- or off-site landslides, lateral spreading, subsidence, liquefaction or collapse?				X
d) Be located on expansive soil, as defined of the latest in Table 18-1-B Uniform Building Code, creating substantial risk to life or property?				X
e) Have soils incapable of adequately supporting the use of septic tanks or alternative waste water disposal systems where sewers are not available for the disposal of waste water?				X
f) Directly or indirectly destroy a unique paleontological resource or site or unique geologic feature?				X

Background

The parcel is currently vacant and zoned for residential uses. At the time of “Building Permitting” any soil issues that can arise, foreseen and unforeseen will be addressed.

Impact Discussion

- a) **No Impact.** Project and zone change is to allow for a multi-family residential use, the proposed project will not cause or expose people or structures to potential substantial adverse effects, including risk of loss, injury, or death involving rupture of a known earthquake fault, as delineated on the most recent Alquist-Priolo Earthquake Fault Zoning Map issued by the State Geologist for the area or based on other substantial evidence of a known fault. Therefore, less than significant impacts are expected.
 - 1. According to the State of California's Alquist-Priolo Earthquake Fault Zone Maps, Revised January 1, 1980, Specials Studies Map, the proposed project site is not located in a "Special Studies Zone". The site could be affected by the occurrence of seismic activity, but no more that the surrounding properties. The project would need to comply with the California Building Code (CBC). Compliance with the CBC would reduce the risk to a level less than significant.

2. Per the City of Imperial Conservation and Open Space Element, the project site is in a high seismic area. However, any potential impact would not be greater to the project site than elsewhere in the region. The main concern of ground shaking is the corresponding structure damage and the related hazards to life and safety. To ensure the structural integrity of all buildings and structures, the project must conform to the Seismic Requirements as outlined in the California Building Code. Compliance with the CBC does not eliminate the risk associated with ground shaking; however, it would reduce the risk to a level less than significant.
 3. The project site is on relatively flat terrain and is not within a "Landslide Susceptibility Area" as identified by the GGS Seismic Hazard Zonation's Program (SHZP) Data Access Page, and the Imperial County General Plan, Seismic and Public Safety Element, Figure 2 (Landslide Activities). Additionally, the project site is not adjacent to any shore line and, therefore is not subject to a seiche or tsunami.
- b) **No Impact.** Project and zone change is to allow for a multi-family residential use. The project site is not located within an erosion susceptible area according to the Imperial County, Seismic and Public Safety Element, Figure 3; therefore, no impact is expected.
 - c) **No Impact.** Mitigation measures are incorporated at the time of "Building Permit Processing" for structure integrity and compliance with CA Building Code standards. The project site is not located on a geological unit or soil that is unstable or would become unstable due to the expansion to this existing facility; therefore, no impact is expected
 - d) **No Impact.** Mitigation measures are incorporated at the time of "Building Permit Processing" for structure integrity and compliance with CA Building Code standards. The project site is not characterized by any expansive soils that would be considered environmentally significant. Potential impact deriving from expansive soils are considered negligible. Therefore, no impacts are anticipated.
 - e) **No Impact.** Mitigation measures are incorporated at the time of "Building Permit Processing" for structure integrity and compliance with CA Building Code standards.

VIII. GREENHOUSE GAS EMISSIONS – Would the project:					
		Potentially Significant Issues	Potentially Significant Unless Mitigation Incorporated	Less Than Significant Impact	No Impact
a)	Generate greenhouse gas emissions, either directly or indirectly, that may have a significant impact on the environment?				X
b)	Conflict with an applicable plan, policy or regulation adopted for the purpose of reducing the emissions of greenhouse gases?				X

Background

The proposed residential project will not have an impact on greenhouse gas emissions.

Impact Discussion

- a) **No Impact.** Will not generate greenhouse gas emissions, either directly or indirectly, that may have a significant impact on the environment however, construction impacts would short term with minimal impacts. Any future development shall comply with the Imperial County Air Pollution Control District rules and regulations. The impacts are anticipated to be less than significant.
- b) **No Impact.** Will not conflict with an applicable plan, policy or regulation adopted for the purpose of reducing the emissions of greenhouse gases.

IX. HAZARDS AND HAZARDOUS MATERIALS – Would the project:				
	Potentially Significant Issues	Potentially Significant Unless Mitigation Incorporated	Less Than Significant Impact	No Impact
a)	Create a significant hazard to the public or the environment through the routine transport, use, or disposal of hazardous materials?		X	
b)	Create a significant hazard to the public or the environment through reasonable foreseeable upset and accident conditions involving the release of hazardous materials into the environment?			X
c)	Emit hazardous emissions or handle hazardous or acutely hazardous materials, substances, or waste within a quarter-mile of an existing or proposed school?			X
d)	Be located on a site, which is included on a list of hazardous materials sites compiled pursuant to Government Code Section 65962.5 and, as a result, would it create a significant hazard to the public or the environment?			X
e)	For a project located within an airport land use plan or, where such a plan has not been adopted, within two miles of a public airport or public use airport, would the project result in a safety hazard for people residing or working in the project area?			X
f)	For a project within the vicinity of a private airstrip, would the project result in a safety hazard for people residing or working in the project area?			X
g)	Impair implementation of or physically interfere with an adopted emergency response plan or emergency evacuation plan?			X
h)	Expose people or structures to a significant risk of loss, injury or death involving wildland fires including where wildlands are adjacent to urbanized areas or where residences are intermixed with wildlands?			X

Background

The proposed project is for a multifamily residential use. The project is not going to bring nor generate any hazardous materials or uses to the area.

Impact Discussion

- a) **Less Than Significant Impact.** Will not create a significant hazard to the public or the environment through the routine transport, use, or disposal of hazardous materials. The project area may be impacted by aerial application using pesticide spray application on the existing and surrounding farm ground. Additionally, the project area may contain hazardous material that are used for abatement of weeds and insects; however, the applicant does not intend to change the current use of the parcel and therefore, any hazardous material impacts would be maintained at a level less than significant.
- b) **No Impact.** Will not create a significant hazard to the public or the environment through reasonable foreseeable upset and accident conditions involving the release of hazardous materials into the environment

- c) **No Impact.** Will not emit hazardous emissions or handle hazardous or acutely hazardous materials, substances, or waste within a quarter-mile of an existing or proposed school.
- d) **No Impact.** Will not create a significant hazard to the public or the environment. The project site is not located on a site included on a list of hazardous material sites; therefore, no impact expected.
- e) **No Impact.** Will not result in a safety hazard for people residing or working in the project area
- f) **No Impact.** Will not result in a safety hazard for people residing or working in the project area.
- g) **No Impact.** Will not impair implementation of or physically interfere with an adopted emergency response plan or emergency evacuation plan.
- h) **No Impact.** Will not expose people or structures to a significant risk of loss, injury or death involving wildland fires including where wildlands are adjacent to urbanized areas or where residences are intermixed with wildlands. The project site is not located in an area susceptible to wildland fires, therefore, no impact is expected.

X. HYDROLOGY AND WATER QUALITY – Would the project:					
		Potentially Significant Issues	Potentially Significant Unless Mitigation Incorporated	Less Than Significant Impact	No Impact
a)	Violate any water quality standards or waste discharge requirements?			X	
b)	Substantially deplete groundwater supplies or interfere substantially with groundwater recharge such that there would be a net deficit in aquifer volume or a lowering of the local groundwater table level (e.g., the production rate of pre-existing nearby wells would drop to a level which would not support existing land uses or planned uses for which permits have been granted)?				X
c)	Substantially alter the existing drainage pattern of the site or area, including through the alteration of the course of a stream or river, in a manner which would result in substantial erosion or situation on- or off-site?				X
d)	Substantially alter the existing drainage pattern of the site, including through the alteration of the course of a stream or river, in a manner which would result in flooding on- or off-site?				X
e)	Create or contribute runoff water, which would exceed the capacity of existing or planned storm water drainage systems or provide substantial additional sources of polluted runoff?				X
f)	Otherwise substantially degrade water quality?				X
g)	Place housing within a 100-year flood hazard area as mapped on a Flood Hazard Boundary or Flood Insurance Rate Map or other flood hazard delineation map?				X
h)	Place within a 100-year flood area structures which would impede or redirect the flood flows?				X

i)	Expose people or structures to a significant risk of loss, injury or death involving flooding, including flooding as a result of the failure of a levee or dam?				X
j)	Inundation, mud flow or water run-off?				X

Background

The proposed project will not create a detrimental impact on water resources within the city. If any unforeseen issues arise, the applicant will have to mitigate them during the building permitting process. The Project site presently consists of vacant land with sparse vegetation. Therefore potential hazards for slope instability are unlikely. The increase in residential density will increase the existing rates of runoff due to increased sealed surface areas. The incorporation of an adequate drainage management plan will help minimize any substantial risk of erosion or situation on or off-site. The drainage plan is subject to review by the City Public Works and Engineering Department for consistency with City Standards.

A drainage report will be prepared to adequately assess the potential for adverse hydrological and drainage effects associated with short-term construction and longer-term operation of the proposed project. Findings and recommendations from the prepared Hydrology report will further be incorporated as mitigation measures for the project. Site development would include clearing and grubbing of vegetation, site grading, underground utility installation and construction of retention basins.

Impact Discussion

- a) **Less Than Significant Impact.** Will not violate any water quality standards or waste discharge requirements. No discharge of any industrial or process wastewater is proposed, but if the applicant commences to discharge any industrial or processed wastewater, the applicant will need to work the Regional Water Quality Control Board for permitting said discharge. However, less than significant impacts are anticipated. Implementation of the proposed Project may result in short term and long term changes to site drainage characteristics. Preparation of a Stormwater Pollution Prevention Plan (SWPPP) would be required for the proposed Project site to ensure consistency with all applicable water quality standards as well as implementation of Best Management Practices (BMPs).
- b) **No Impact.** The proposed Project would rely on municipal water for both short-term and long-term operation. The proposed zone change and multifamily apartment complex will not substantially deplete groundwater; therefore, no impacts are expected.
- c) **No Impact.** The proposed zone change and multifamily apartment complex will not substantially alter the existing drainage pattern of the site or area, resulting in substantial erosion or siltation on- or off-site, therefore, no impacts are expected. The soils at the site are subject to wind and water erosion, especially during Project construction. However, implementation of the SWPPP and BMPs would reduce impacts to less than significant. Areas not paved or constructed would be landscaped in accordance with City of Imperial requirements. Therefore, the likelihood of soil erosion or loss of topsoil would be minimized.
- d) **No Impact.** The proposed zone change and multifamily apartment complex will not substantially alter the existing drainage patterns or increase the rate or amount of surface runoff, resulting in flooding on- or off-site; therefore, no impact are expected. Additionally, Imperial County Public Works will require that a drainage and grading plan/study/letter be submitted at the time of development. Therefore, any impacts are expected to be less than significant.
- e) **No Impact.** The proposed zone change and multifamily apartment complex will not create or contribute runoff water, which would exceed the capacity of existing or planned storm water drainage systems or provide substantial additional sources of polluted runoff. The proposed on-site detention basin and landscaped areas will

accommodate the water run-off from the Project site. Construction activities on the project site would be subject to Best Management Practices (BMP's) and a Storm Water Pollution Prevention Plan (SWPPP) to minimize pollution on and off-site

- f) **No Impact.** The proposed zone change and multifamily apartment complex will not otherwise substantially degrade water quality, and; therefore, no impact is expected.
- g) **No Impact.** Will not place housing within a 100-year flood hazard area as mapped on a Flood Hazard Boundary or Flood Insurance Rate Map or other flood hazard delineation map. Per FEMA Flood Map #06025C1700C the project site is not located with a flood area. Therefore, no impact is expected.
- h) **No Impact.** Will not place within a 100-year flood area structures which would impede or redirect the flood flows and would not require the placement of structures within 100-year flood hazard area, which would impede or redirect flood flow, therefore, no impact is expected.
- i) **No Impact.** Will not expose people or structures to a significant risk of loss, injury or death involving flooding, including flooding as a result of the failure of a levee or dam.
- j) **No Impact.** The proposed zone change and multifamily complex would not expose people or structures to a significant risk or lost, injury or death involving inundation by seiche, tsunami, or mudflow, therefore, no impact is expected.

<i>XI. LAND USE AND PLANNING</i> – Would the proposal:					
		Potentially Significant Issues	Potentially Significant Unless Mitigation Incorporated	Less Than Significant Impact	No Impact
a)	Physically divide an established community?				X
b)	Conflict with any applicable land use plan, policy, or regulation of an agency with jurisdiction over the project (including, but not limited to, the general plan, specific plan, local coastal program, or zoning ordinance) adopted for the purpose of avoiding or mitigating an environmental effect?				X
c)	Conflict with any applicable habitat conservation plan or natural community conservation plan?				X

Background

The proposed project will serve as infill in the community and the City of Imperial because it is to be located on Vacant residentially zoned parcels. The proposed zone change is consistent General Plan's Land Use Elements goals, objectives, and policies.

Impact Discussion

- a) **No Impact.** The proposed project will not physically divide an established community.

- b) **No Impact.** Will not conflict with any applicable land use plan, policy, or regulation of an agency with jurisdiction over the project (including, but not limited to, the general plan, specific plan, local coastal program, or zoning ordinance) adopted for the purpose of avoiding or mitigating an environmental effect.
- c) **No Impact.** The proposed Project would not conflict with any applicable habitat conservation plan or natural community conservation plan because the site is currently used as a residential property and is not identified as suitable habitat for plan and/or animal species.

<i>XII. MINERAL RESOURCES</i> – Would the project:					
		Potentially Significant Issues	Potentially Significant Unless Mitigation Incorporated	Less Than Significant Impact	No Impact
a)	Result in the loss of availability of a known mineral resource that would be of value to the region and the residents of the state?				X
b)	Result in the loss of availability of a locally-important mineral resource recovery site delineated on a local general plan, specific plan or other land use plan?				X

Background

The project is not located in an area that is considered by the State of California a “mineral resource” source, thus it will not impact this item.

Impact Discussion

- a) **No Impact.** Will not result in the loss of availability of a known mineral resource that would be of value to the region and the residents of the state. The proposed zone change and tentative multifamily complex will not remove mineral resources on-site; therefore, no impact expected.
- b) **No Impact.** The proposed zone change and multifamily apartment complex not result in the loss of availability of a locally-important mineral resource recovery site delineated on a local general plan, specific plan or other land use plan.

XIII. NOISE – Would the project result in:				
	Potentially Significant Issues	Potentially Significant Unless Mitigation Incorporated	Less Than Significant Impact	No Impact
a) Exposure of persons to or generation of noise levels in excess of standards established in the local general plan or noise ordinance, or applicable standards of other agencies?				X
b) Exposure of persons to or generation of excessive ground borne vibration or ground borne noise levels?				X
c) A substantial permanent increase in ambient noise levels in the project vicinity above levels existing without the project?				X
d) A substantial temporary or periodic increase in ambient noise levels in the project vicinity above levels existing without the project?				X
e) For a project located within an airport land use plan or where such a plan has not been adopted, within two miles of a public airport or public use airport, would the project expose people residing or working in the project area to excessive noise levels?				X
f) For a project within the vicinity of a private airstrip, would the project expose people residing or working in the project area to excessive noise levels?				X

Background

The proposed project will comply with the noise element for that zone.

Impact Discussion

- a) **No impact.** The proposed project will not expose persons to or generate noise levels in excess of standards established in the local general plan or noise ordinance, or applicable standards of other agencies. The proposed project is not expected to create substantial permanent increase in ambient noise levels in the project vicinity above levels existing without the project. Therefore, less than significant impacts are expected.
- b) **No Impact.** The proposed project will not expose persons to or generate excessive ground borne vibration or ground borne noise levels.
- c) **No impact.** The zone change will not create a substantial permanent increase in ambient noise levels in the project vicinity above levels existing without the project. The project is not expected to create substantial permanent increase in ambient noise levels in the project vicinity above levels existing without the project. Therefore, less than significant impacts are expected.
- d) **No impact.** Will not create a substantial temporary or periodic increase in ambient noise levels in the project vicinity above levels existing without the project. The proposed zone change, is not expected to create a substantial temporary or periodic increase in ambient noise levels in the project vicinity above levels existing without the project. Therefore less than significant impacts are expected. Construction of the proposed Project could result in an increase in the existing ambient noise environment. Construction levels at the nearest noise sensitive locations would be approximately 89 dBA. Additionally, phased development of the proposed Project would result in increased noise levels compared to pre-construction phases. Mitigation would be required to minimize construction noise in these areas. These measures include, but are not limited to: limiting the hours of construction and use of mufflers on construction equipment

- e) **No impact.** Will not expose people residing or working in the project area to excessive noise levels. According to the Imperial County Airport Land Use Compatibility Plan, the Project site is located within the “**D**” Zone which is within the “Other Airport Environs” location. According to the Plan, there is negligible risk to residents in this Zone, but there is potential for annoyance from overflights. There are no limits within this Zone in regard to density and no requirements for open land. An aviation easement exists on the project site and would be continued with the resubdivision.
- f) **No impact.** The project is not located near a private airstrip. The proposed project site is not within the vicinity of a private airport nor is it within the close vicinity of a private airstrip. Therefore, the proposed water well will not result in any

<i>XIV. POPULATION AND HOUSING – Would the project:</i>					
		Potentially Significant Issues	Potentially Significant Unless Mitigation Incorporated	Less Than Significant Impact	No Impact
a)	Induce substantial population growth in an area either directly (for example, by proposing new homes and businesses) or indirectly (for example, through extension of roads or other infrastructure)?			X	
b)	Displace substantial numbers of existing housing, necessitating the construction of replacement housing elsewhere?				X
c)	Displace substantial numbers of people, necessitating the construction of replacement housing elsewhere?				X

Background

The zone change and multifamily apartment project is proposed to be on parcels that are already zoned for residential uses.

Impact Discussion

- a) **Less than Significant Impact.** The zone change would not induce substantial population growth in the area either directly or indirectly, the parcels are already zoned for Residential Single Family Uses. While there would be impacts, the impacts would appear to be less than significant.
- b) **No Impact.** The project is proposed to be developed on currently vacant land and would not displace substantial numbers of exiting housing, necessitating the construction of replacement housing elsewhere; therefore, no impact is expected.
- c) **No Impact.** The land that the project is proposed to be developed on is currently vacant. The proposed development will not displace substantial numbers of people necessitating the construction or replacement housing elsewhere; therefore, no impact is expected.

XV. PUBLIC SERVICES:

a) Would the project result in substantial adverse physical impacts associated with the provision of new or physically altered governmental facilities, need for new or physically altered governmental facilities, the construction of which could cause significant environmental impacts, in order to maintain acceptable service ratios, response times or other performance objectives for any of the public services:	Potentially Significant Issues	Potentially Significant Unless Mitigation Incorporated	Less Than Significant Impact	No Impact
1) Fire protection?			X	
2) Police protection?			X	
3) Schools?			X	
4) Parks?			X	
5) Other public facilities?			X	

Background

The project will not result in substantial adverse physical impacts associated with the provision of new or physically altered governmental facilities, need for new or physically altered governmental facilities, the construction of which could cause significant environmental impacts, in order to maintain acceptable service ratios, response times or other performance objectives for any of the public services.

Impact Discussion

- 1) **Less Than Significant Impact.** At the time of building permit processing the applicant will comply with any requirements needed by the fire department. The proposed zone change is not expected to result in substantial impacts on fire protection; however, any new impacts would be less than significant. The installation of fire hydrants within the Project site will offer increased fire protection to the Project area and therefore the impact should be less than significant.
 - a)
 - b) **Less Than Significant Impact.** The police department did not impose nor express any safety concern issues regarding the proposed development. The proposed zone change is not expected to have result in substantial impacts on police protection; any new impacts would be less than significant.
 - c) **Less Than Significant Impact.** The developer is required to pay “school fees” to help mitigate any potential increase in service the project may create. The proposed zone change is not expected to have an impact on schools; therefore, any new impacts would be less than significant.
 - d) **Less Than Significant Impact.** The developer is required to pay development impact fees for “parks” to the City of Imperial as well as provide recreational areas onsite of the development for the residents. The proposed zone change is not expected to create a substantial impact on parks; therefore, less than significant impact would be expected.
 - e) **Less Than Significant Impact.** There are no foreseeable impacts to other public facilities at the time of this evaluation based on the proposed use. The proposed zone change is not expected to create a substantial impact on other public facilities; therefore, less than significant impacts would be expected.

XVI. RECREATION:				
	Potentially Significant Issues	Potentially Significant Unless Mitigation Incorporated	Less Than Significant Impact	No Impact
a) Would the project increase the use of the existing neighborhood and regional parks or other recreational facilities such that substantial physical deterioration of the facility would occur or be accelerated?			X	
b) Does the project include recreational facilities or require the construction or expansion of recreational facilities which might have an adverse effect on the environment?				X

Background

The proposed multifamily development will have onsite outdoor picnic areas for the residents. The developer is also required to pay development impact fees to help offset potential recreational needs due to the development.

Impact Discussion

- a) **Less Than Significant Impact.** The proposed zone change could increase the use of the existing neighborhood and regional parks or other recreational facilities; however, the increase would be minor; therefore, less than significant impact would be expected.
- b) **No Impact.** The Developers are required to pay “Development Impact Fees” and provide recreational areas as per the Cities ordinance for residential developments. The proposed zone change does not include or require the construction of recreational facilities; therefore, no impact is expected.

XVII. TRANSPORTATION – Would the project:				
	Potentially Significant Issues	Potentially Significant Unless Mitigation Incorporated	Less Than Significant Impact	No Impact
a) Cause an increase in traffic, which is substantial in relation to the existing traffic load and capacity of the street system (<i>i.e.</i> , result in a substantial increase in either the number of vehicle trips, the volume to capacity ratio on roads or congestion at intersections)?			X	
b) Exceed, either individually or cumulatively, a level of service standard established by the county congestion/management agency for designated roads or highways?				X
c) Result in a change in air traffic patterns, including either an increase in traffic levels or a change in location that result in substantial safety risks?				X
d) Substantially increase hazards due to a design feature (<i>e.g.</i> , sharp curves or dangerous intersections) or incompatible uses (<i>e.g.</i> , farm equipment)?				X
e) Result in inadequate emergency access?				X
f) Result in insufficient parking capacity?				X

g)	Conflicts with adopted policies, plans, programs, supporting alternative transportation (e.g., bus turnouts, bicycle racks)?				X
h)	Conflicts or be inconsistent with CEQA Guidelines section 15064.3, subdivision (b)?				X

Background

The project is a proposed multifamily development to be constructed on vacant land that is zoned residential for single-family developments. The project will have to comply with all development requirements the City of Imperial formulates to mitigate potential traffic congestion. The project will have to comply with all development requirements the City of Imperial formulates to mitigate potential traffic congestion that may result before or after the development is constructed.

If the subject site were to be developed with Residential Single Family developments (homes), the parcels could generate up to 1234.2 average daily trips (ADT's). If the zone is changed to "RA", the site could generate up to 2040 ADT's based on a the maximum density and lot coverage permitted within the zone, which could be less since there is not an official proposal project amount on behalf of the applicant. All ADT projections are based on San Diego Association of Governments (SANDAG) Trip Generation Rates. The developer must incorporate, provide and install all traffic mitigation measures that are formulated by the City of Imperials Traffic Commission and approved by the City engineer and developer's engineer and that are within the Traffic Study for Morningstar Subdivision before building permits are obtained and/or certificates of occupancy. Developer provided a traffic study and mitigation measures were identified and are made part of.

Impact Discussion

- a) **Less than Significant Impact.** The project is proposed to be in a zoning district that can with stand the potential generation of traffic. Measures will be implemented at the time of construction to prevent any type of potentially adverse effects in regards to traffic. The proposed zone change is not expected to create a substantial impact to surrounding roads; however any new impacts would appear to be less than significant. The Multifamily project could potentially increase average daily trips by 805 ADTs, but all roadway segments and intersections will continue to operate at LOS C or better.
- b)
- c) **No Impact.** The project will not exceed, either individually or cumulatively, a level of service standard established by the county congestion/management agency for designated roads or highways.
- d) **No Impact.** Will not result in a change in air traffic patterns, including either an increase in traffic levels or a change in location that result in substantial safety risks.
- e) **No Impact.** The proposed project will not create any exposure to hazardous materials.
- f) **No Impact.** The project will not result in inadequate emergency access.
- g) **No Impact.** The proposed development will have to comply with the City of Imperial's development standards in all aspects. The development must have enough parking for the proposed use and it will not result in insufficient parking.
- h) **No Impact.** The proposed project will not conflicts with adopted policies, plans, programs, supporting alternative transportation
- i) **No Impact.** The project will not have an adverse effect nor be inconsistent with CEQA Guidelines section 15064.3, subdivision (b).

XVIII. TRIBAL CULTURAL RESOURCES – Would the project:				
	Potentially Significant Issues	Potentially Significant Unless Mitigation Incorporated	Less Than Significant Impact	No Impact
a) Would the project cause a substantial adverse change in the significance of a tribal cultural resource, defined in Public Resources Code section 21074 as either a site, feature, place, cultural landscape that is geographically defined in terms of the size and scope of the landscape, sacred place, or object with cultural value to a California Native American tribe, and that is:				X
b) Listed or eligible for listing in the California Register of Historical Resources, or in a local register of historical resources as defined in Public Resources Code section 5020.1 (k), or				X
c) A resource determined by the lead agency, in its discretion and supported by substantial evidence, to be significant pursuant to criteria set forth in subdivision of Public Resource Code Section 5024.1, the lead agency shall consider the significance of the resource to a California Native American tribe				X

Background

The project is proposed to be on vacant land located within a urbanized area. The parcels are zoned for Residential uses. There have not been reports of the parcels nor the area to have any ties to tribal culture or resources.

Impact Discussion

- a) **No Impact.** The project is proposed to be on vacant land. Based on Figure 6 Known Areas of Native American Sensitivity of the Conservation and Open Space Element of the Imperial County General Plan, the project site is not located with any sensitive area.
- b) **No Impact.** The land is vacant and not listed or eligible for listing in the California Register of Historical Resources, or in a local register of historical resources as defined in Public Resources Code section 5020.1 (k). The proposed project would not cause a substantial change in the significance of a tribal cultural resource and no historical resources have been identified as significant in the project area.
- c) **No Impact.** The project has not been determined to be significant pursuant to criteria set forth in subdivision of Public Resource Code Section 5024.1, the lead agency shall consider the significance of the resource to a California Native American tribe.

XIX. UTILITIES AND SERVICE SYSTEMS – Would the project:					
		Potentially Significant Issues	Potentially Significant Unless Mitigation Incorporated	Less Than Significant Impact	No Impact
a)	Exceed wastewater treatment requirements of the applicable Regional Water Quality Control Board?				X
b)	Require or result in the construction of new storm water or water treatment facilities or expansion of existing facilities, the construction of which could cause significant environmental effects?				X
c)	Require or result in the construction of new storm water drainage facilities or expansion of existing facilities, the construction of which could cause significant environmental effects?				X
d)	Have sufficient water supplies available to serve the project from existing entitlements and resources, or are new or expanded entitlements needed?				X
e)	Result in a determination by the wastewater treatment provider which serves or may serve the project that it has adequate capacity to serve the project's projected demand in addition to the provider's existing commitments?				X
f)	Be served by a landfill with sufficient permitted capacity to accommodate the project's solid waste disposal needs?				X
g)	Comply with federal, state, and local statutes and regulations related to solid waste?				X

Background

The project is a proposed multifamily development to be constructed on vacant land that is zoned residential for single-family developments. The applicant is aware and subject to conditions of approval to ensure that the project and city are provided and served with all the necessary utilities to properly function and meet all local and state regulation requirements when it comes to water and sewer. The Project will require water and sewer line extensions connecting to the existing water and wastewater infrastructure, as well as the construction of new infrastructure.

Impact Discussion

- a) **No Impact.** The project will not exceed wastewater treatment requirements of the applicable Regional Water Quality Control Board. The proposed zone change will not exceed wastewater treatment requirements of the Regional Water Quality Control Board; therefore, no impacts are expected.
- b) **No Impact.** The project will not require new facilities to be constructed because of the use. The proposed zone change will not result in the construction of new water or water treatment facilities or expansion of existing facilities. Therefore, no impact is expected.
- c) **No Impact.** None of the proposed construction will cause environmental constraints. The proposed zone change will not result in the construction of a new storm water drainage facilities or expansion of existing facilities; therefore, no impact is expected.
- d) **No Impact.** The proposed project will have sufficient water supplies available to serve the project from existing entitlements and resources, or are new or expanded entitlements needed.

- e) **No Impact.** The proposed zone change will not result in a determination by a wastewater treatment provider that services or may service the project that it does not have adequate capacity to the project's projected demands in additions to the provider's existing commitments. At the time of the Building Permit application process, the developer will supply the city with a Hydrology flow test, to ensure the use will have adequate water supply and if not the developer will mitigate the issue.
- f) **No Impact.** The project will be served by a landfill with sufficient capacity to accommodate the project's solid waste disposal needs.
- g) **No Impact.** The project will comply with federal, state, and local statutes and regulations related to solid waste.

XX. WILDFIRE – If located near or near state responsibility areas or lands classified as very high fire hazard severity zones, Would the project:				
	Potentially Significant Issues	Potentially Significant Unless Mitigation Incorporated	Less Than Significant Impact	No Impact
a) Substantially impair an adopted emergency response plan or emergency evacuation plan?				X
b) Due, to slope, prevailing winds, and other factors, exacerbate wildfire risks, and thereby expose project occupants to, pollutant concentrations from a wildfire or the uncontrolled spread of a wildfire?				X
c) Require the installation or maintenance of associated infrastructure (such as roads, fuel breaks, emergency water sources, power lines or other utilities) that may exacerbate fire risk or that may result in temporary or ongoing impacts to the environment?				X

Background

The City of Imperial is part of the Imperial County, which is within the State of California. We are the only county, that has not been assessed by the state of California for “WILDFIRE” threats.

Impact Discussion

- a) **No Impact.** No risk of wildfire at the proposed projects location.
- b) **No Impact.** No risk of wildfire at the proposed projects location.
- c) **No Impact.** No risk of wildfire at the proposed projects location.

XXI. MANDATORY FINDINGS OF SIGNIFICANCE					
a)	Does the project have the potential to degrade the quality of the environment, substantially reduce the habitat of a fish or wildlife species, cause a fish or wildlife population to drop below self-sustaining levels, threaten to eliminate a plant or animal community, reduce the number or restrict the range of a rare or endangered plant or animal, or eliminate important examples of the major periods of California history or prehistory?				X
b)	Does the project have impacts that are individually limited, but cumulatively considerable? (“Cumulatively considerable” means that the incremental effects of a project are considerable when viewed in connection with the effects of past projects, the effects of other current projects, and the effects of probable future projects.)				X
c)	Does the project have environmental effects that will cause substantial adverse effects on human beings, either directly or indirectly?				X

Background

The project is a proposed zone change from R-1 (Single-Family Residential) to R-A (Residential Apartment) Multi-family development to be constructed on vacant land that is zoned residential for Single-family uses.

Impact Discussion

- a) **No Impact.** The project is proposed to be on parcels that are currently vacant and zoned residential for single-family developments.
- b) **No Impact.** The does not have impacts that are individually limited, but cumulatively considerable.
- c) **No Impact.** The project does not have environmental effects that will cause substantial adverse effects on human beings, either directly or indirectly.

SOURCE REFERENCES	
The following documents were used as sources of factual data and are hereby incorporated as part of this Environmental Checklist. Because of the voluminous nature of the documents, copies of the following documents are not distributed with this document but may be obtained from the City of Imperial.	
A	City of Imperial Zoning Ordinance
B	City of Imperial General Plan
C	City of Imperial Service Area Plan
D	Air Pollution Control District CEQA Air Quality Handbook
E	County of Imperial Airport Land Use Compatibility Plan

Heritage at Dahlia Ranch

Traffic Study

Prepared for:

Heritage at Dahlia Ranch, LLC
341 Crown Court
Imperial, CA 92251

Prepared by:

Marc Mizuta, PE, TE, PTOE



5694 Mission Center Road, #602-121
San Diego, CA 92108

November 2021

TABLE OF CONTENTS

1	INTRODUCTION	1
1.1	PROJECT DESCRIPTION.....	1
2	ANALYSIS APPROACH AND METHODOLOGY	6
2.1	STUDY AREA.....	6
2.2	ANALYSIS SCENARIOS.....	7
2.3	METHODOLOGY.....	7
2.3.1	<i>Intersection Level of Service Analysis</i>	7
2.3.2	<i>Roadway Segment Analysis</i>	8
2.4	IMPROVEMENT CRITERIA	9
3	EXISTING CONDITIONS.....	10
3.1	ROADWAY NETWORK	10
3.2	TRAFFIC VOLUMES.....	12
3.3	INTERSECTION ANALYSIS	15
3.4	ROADWAY SEGMENT ANALYSIS.....	16
4	PROJECT TRAFFIC	17
4.1	TRIP GENERATION.....	17
4.2	TRIP DISTRIBUTION AND ASSIGNMENT	19
4.3	PROJECT TRIP ASSIGNMENT.....	30
5	CUMULATIVE PROJECT TRAFFIC	41
5.1	CUMULATIVE PROJECTS.....	41
6	OPENING YEAR 2023.....	45
6.1	ROADWAY NETWORK	45
6.2	TRAFFIC VOLUMES.....	45
6.3	INTERSECTION ANALYSIS	45
6.4	ROADWAY SEGMENT ANALYSIS.....	53
7	OPENING YEAR 2024	54
7.1	ROADWAY NETWORK	54
7.2	TRAFFIC VOLUMES.....	54
7.3	INTERSECTION ANALYSIS	54
7.4	ROADWAY SEGMENT ANALYSIS.....	62
8	OPENING YEAR 2026	63
8.1	ROADWAY NETWORK	63
8.2	TRAFFIC VOLUMES.....	63
8.3	INTERSECTION ANALYSIS	63
8.4	ROADWAY SEGMENT ANALYSIS.....	71
9	OPENING YEAR 2028.....	72
9.1	ROADWAY NETWORK	72
9.2	TRAFFIC VOLUMES.....	72
9.3	INTERSECTION ANALYSIS	72
9.4	ROADWAY SEGMENT ANALYSIS.....	80

LIST OF FIGURES

Figure 1-1 Project Vicinity Map 2
 Figure 1-2 Site Plan 3
 Figure 1-3 Phasing Plan 4
 Figure 3-1 Existing Intersection Geometrics 11
 Figure 3-2 Existing Conditions Traffic Volumes 13
 Figure 4-1 Phase 1 Project Trip Distribution 20
 Figure 4-2 Phase 2 Project Trip Distribution 22
 Figure 4-3 Phase 3 (Multi-Family) Project Trip Distribution 24
 Figure 4-4 Phase 3 (Commercial/Retail) Project Trip Distribution 26
 Figure 4-5 Phase 4 Project Trip Distribution 28
 Figure 4-6 Phase 1 Trip Assignment 31
 Figure 4-7 Phase 2 Trip Assignment 33
 Figure 4-8 Phase 3 (Multi-Family) Trip Assignment 35
 Figure 4-9 Phase 3 (Commercial/Retail) Trip Assignment 37
 Figure 4-10 Phase 4 Trip Assignment 39
 Figure 5-1 Cumulative Project Location Map 42
 Figure 5-2 Cumulative Project Traffic Volumes – Year 2026 43
 Figure 5-3 Cumulative Project Traffic Volumes – Year 2028 44
 Figure 6-1 Opening Year 2023 Phase 1 Intersection Geometrics 46
 Figure 6-2 Opening Year 2023 Baseline Traffic Volumes 48
 Figure 6-3 Opening Year 2023 Plus Phase 1 Project Traffic Volumes 50
 Figure 7-1 Opening Year 2024 Phase 2 Intersection Geometrics 55
 Figure 7-2 Opening Year 2024 Baseline Traffic Volumes 57
 Figure 7-3 Opening Year 2024 Plus Phases 1 & 2 Project Traffic Volumes 59
 Figure 8-1 Opening Year 2026 Phase 3 Intersection Geometrics 64
 Figure 8-2 Opening Year 2026 Baseline Traffic Volumes 66
 Figure 8-3 Opening Year 2026 Plus Phases 1 to 3 Project Traffic Volumes 68
 Figure 9-1 Opening Year 2028 Phase 4 Intersection Geometrics 73
 Figure 9-2 Opening Year 2028 Baseline Traffic Volumes 75
 Figure 9-3 Opening Year 2028 Plus Phases 1 to 4 Project Traffic Volumes 77

LIST OF TABLES

Table 2-1 LOS Criteria for Intersections 8
 Table 2-2 LOS Criteria for Roadway Segments 9
 Table 3-1 Existing Peak Hour Intersection LOS Summary 15
 Table 3-2 Existing Roadway Segment LOS Summary 16
 Table 4-1 Trip Generation Rates 17
 Table 4-2 Weekday Trip Generation Summary 18
 Table 6-1 Opening Year 2023 Peak Hour Intersection LOS Summary 52
 Table 6-2 Opening Year 2023 Roadway LOS Summary 53
 Table 7-1 Opening Year 2024 Peak Hour Intersection LOS Summary 61
 Table 7-2 Opening Year 2024 Roadway LOS Summary 62
 Table 8-1 Opening Year 2026 Peak Hour Intersection LOS Summary 70
 Table 8-2 Opening Year 2026 Roadway LOS Summary 71
 Table 9-1 Opening Year 2028 Peak Hour Intersection LOS Summary 79
 Table 9-2 Opening Year 2028 Roadway LOS Summary 80

APPENDICES

Appendix A	SR-86 Relinquishment Map
Appendix B	Existing Traffic Volume Data
Appendix C	Intersection LOS Worksheets
Appendix D	Internal Capture Worksheets
Appendix E	SCAG Profile of Imperial County Report Excerpts

I INTRODUCTION

This traffic study evaluates the traffic conditions associated with the proposed Heritage at Dahlia Ranch project (herein referred to as “the Project”) generally located north of Neckel Road, south of Ralph Road, east of La Brucherie Road, and west of Imperial Avenue in Imperial, CA. **Figure 1-1** shows the location of the project site within the study area. The traffic analyses have been prepared in accordance with the *County of Imperial Department of Public Works Traffic Study and Report Policy, June 29, 2007 (County Guidelines)* and consistent with the countywide goals toward the Congestion Management Program (CMP) in Imperial County.

I.1 Project Description

The Project consists of developing the vacant land into a mixture of residential single-family homes and apartments and various commercial/retail. The project would be constructed over four phases consisting of the following:

- Phase 1: 133 single family residential units
- Phase 2: 133 single family residential units
- Phase 3: 200 apartment units and 92,120 square feet (sf) of various commercial/retail
- Phase 4: 202 single-family residential units

Access for Phase 1 will be provided off Neckel Road. Upon the completing of Phase 2, a secondary access along La Brucherie Road will be constructed. During Phase 3, access to the apartments will be provided off Ralph Road. Access to the commercial/retail uses will be provided off Ralph Road and Imperial Avenue. The construction of the west leg of the La Brucherie Road & Project Driveway intersection will occur in Phase 4 to serve the residential units. **Figure 1-2** illustrates the proposed site plan. **Figure 1-3** illustrates the phasing plan for the Project.

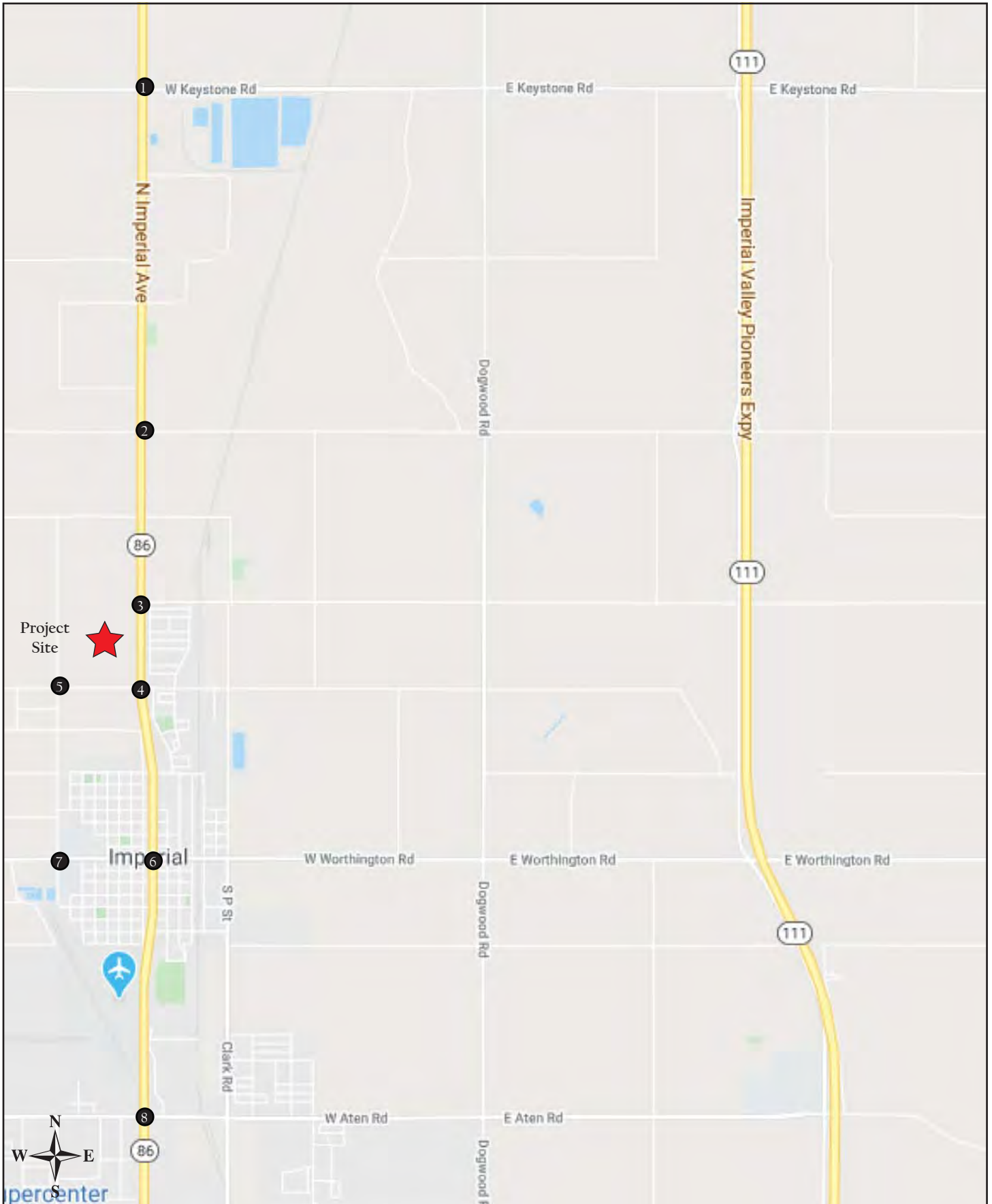

Heritage at Dahlia Ranch

Figure 1-1
Project Vicinity Map

MORNING STAR SUBDIVISION
TENTATIVE MAP - EAST PORTION



Heritage at Dahlia Ranch

Figure 1-2 Site Plan



LEGEND

	Phase 1
	Phase 2
	Phase 3
	Phase 1 Road Network
	Phase 2 Road Network
	Phase 3 Road Network



Heritage at Dahlia Ranch

Figure 1-3
Phasing Plan

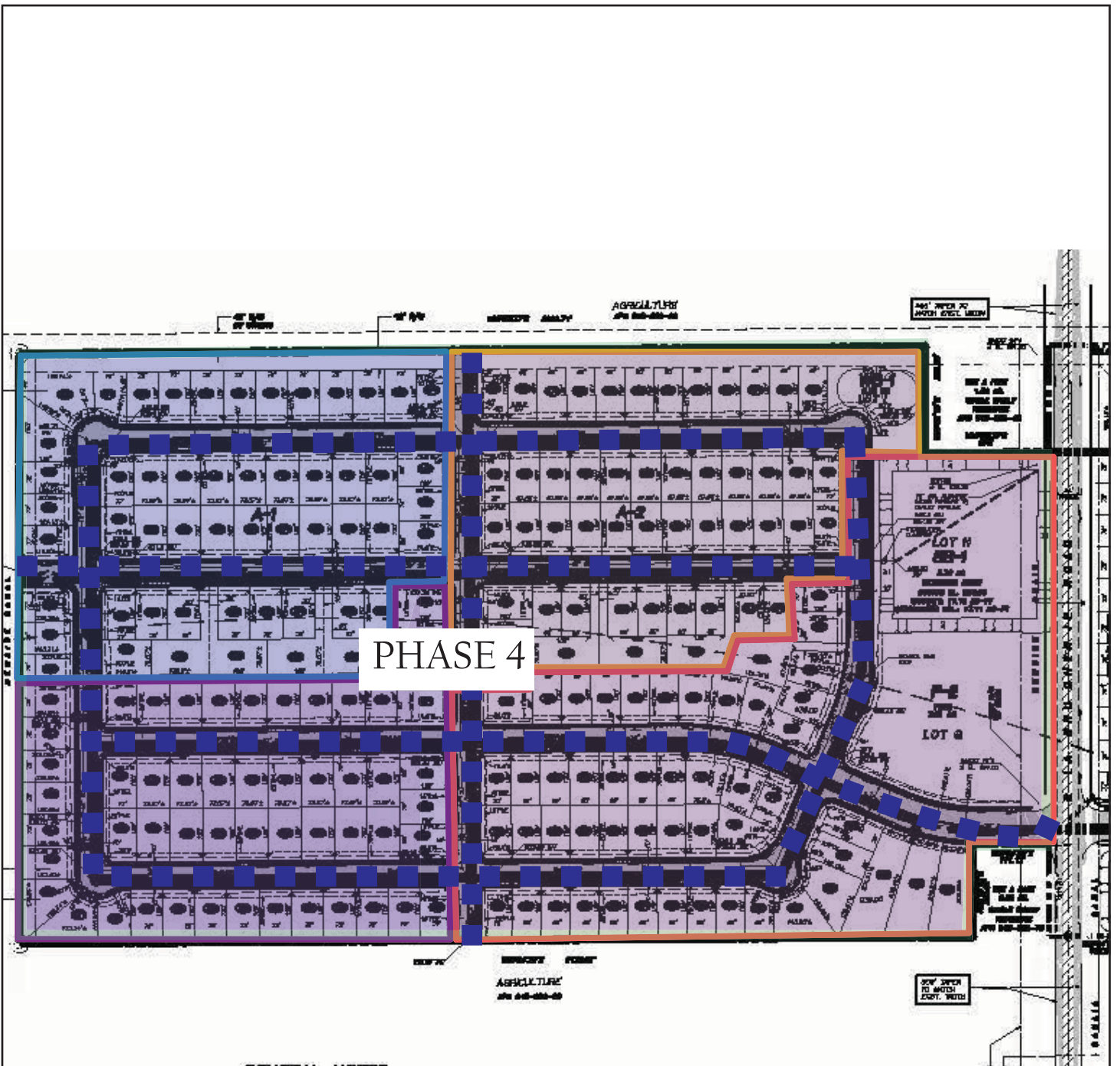

PHASE 4

LEGEND

- Phase 4
- Phase 4 Road Network



Heritage at Dahlia Ranch

Figure 1-3a
Phasing Plan

2 ANALYSIS APPROACH AND METHODOLOGY

This section summarizes the analysis approach and methodology used to evaluate the study intersections and roadway segments associated with the Project.

2.1 Study Area

This traffic study addresses potential operational impacts that could result from the addition of the Project traffic to the local circulation system.

The following intersections and roadway segments are included as part of the study area since they will carry majority of the project traffic:

Intersections

1. SR-86 & Keystone Road
2. SR-86 & Larson Road
3. Imperial Avenue & Ralph Road
4. Imperial Avenue & Neckel Road
5. La Brucherie Road & Neckel Road
6. Imperial Avenue & Worthington Road/Barioni Boulevard
7. La Brucherie Road & Worthington Road
8. Imperial Avenue & Aten Road
9. Project Driveway & Neckel Road (constructed in Phase 1)
10. La Brucherie Road & Project Driveway (constructed in Phase 2, expanded in Phase 4)
11. SFR Project Driveway & Ralph Road (constructed in Phase 3)
12. MFR Project Driveway & Ralph Road (constructed in Phase 3)
13. Retail Project Driveway & Ralph Road (constructed in Phase 3)
14. Imperial Avenue & Project Driveway (constructed in Phase 3)

Segments

1. SR-86 north of Keystone Road
2. SR-86 between Keystone Road and Larsen Road
3. SR-86 between Larsen Road and Ralph Road
4. Imperial Avenue between Ralph Road and Neckel Road
5. Imperial Avenue between Neckel Road and Worthington Road
6. Imperial Avenue between Worthington Road and Aten Road
7. Imperial Avenue south of Aten Road

2.2 Analysis Scenarios

The following scenarios were evaluated as part of the project:

- Existing Conditions: This scenario reflects the existing street network within the study area in the Year 2021.
- Opening Year 2023 Conditions: This scenario reflects the street network assumed to be in place in the Year 2023 and includes traffic from Phase 1 only and cumulative projects.
- Opening Year 2024 Conditions: This scenario reflects the street network assumed to be in place in the Year 2024 and includes traffic from Phases 1 and 2 and cumulative projects.
- Opening Year 2026 Conditions: This scenario reflects the street network assumed to be in place in the Year 2026 and includes traffic from Phases 1 through 3 and cumulative projects.
- Opening Year 2028 Conditions: This scenario reflects the street network assumed to be in place in the Year 2028 and includes traffic from Phases 1 through 4 and cumulative projects.

The traditional weekday peak-hour coinciding with the highest volume of traffic between 7:00 and 9:00 AM and between 4:00 and 6:00 PM was evaluated for each analysis scenario.

2.3 Methodology

2.3.1 Intersection Level of Service Analysis

Signalized and unsignalized intersection operations were analyzed with Synchro II software (Trafficware), using the methodologies outlined in the *Highway Capacity Manual 6th Edition (HCM6)*. The HCM methodology calculates delay, which corresponds to a particular LOS, to describe the overall operation of an intersection. Delay is a measure of driver and/or passenger discomfort, frustration, fuel consumption and lost travel time.

The LOS for unsignalized intersections is determined by the computed or measured control delay and is defined for each minor movement. At a one-way or two-way stop control intersection, the delay reported represents the worst movement, which is typically the left-turns from the minor street approach. The criteria for the LOS grade designations are provided in Table 2-1.

Within the County of Imperial, the threshold for acceptable operating conditions for signalized and unsignalized intersections is LOS C or better.

**Table 2-1
LOS Criteria for Intersections**

LOS	LOS Criteria (sec/veh)		Description
	Signalized Intersections	Unsignalized Intersections	
A	≤10	≤10	EXCELLENT. Operations with very low delay and most vehicles do not stop.
B	>10 and ≤20	>10 and ≤15	VERY GOOD. Operations with good progression but with some restricted movements.
C	>20 and ≤35	>15 and ≤25	GOOD. Operations where a significant number of vehicles are stopping with some backup and light congestion.
D	>35 and ≤55	>25 and ≤35	FAIR. Operations where congestion is noticeable, longer delays occur, and many vehicles stop. The proportion of vehicles not stopping declines.
E	>55 and ≤80	>35 and ≤50	POOR. Operations where there is significant delay, extensive queuing, and poor progression.
F	>80	>50	FAILURE. Operations that are unacceptable to most drivers, when the arrival rates exceed the capacity of the intersection.

Source: *Highway Capacity Manual 6th Edition*

2.3.2 Roadway Segment Analysis

Roadway segment LOS standards and thresholds provide the basis for analysis of arterial roadway segment performance. This analysis is based on the functional classification of the roadway, the maximum capacity, roadway geometrics, and the daily traffic volumes.

Table 2-2 summarizes the capacities for the various roadway classifications with the County of Imperial for each respective LOS.

**Table 2-2
LOS Criteria for Roadway Segments**

Facility Type	X-Section	LOS		
		C or Better	D	E
Expressway	154/210	< 60,000	< 70,000	< 80,000
Prime Arterial	106/136	< 44,600	< 50,000	< 57,000
Minor Arterial	82/102	< 29,600	< 33,400	< 37,000
Major Collector (Collector)	64/84	< 27,400	< 30,800	< 34,200
Minor Collector (Local Collector)	40/70	< 7,100	< 10,900	< 16,200
Local County (Residential)	40/60	< 1,500	*	*
Local County (Residential Cul-de-Sac or Loop Street)	40/60	< 200	*	*
Major Industrial Collector (Industrial)	76/96	< 14,000	< 17,000	< 20,000
Industrial Local	44/64	< 7,000	< 8,500	< 10,000

Source: *Imperial County General Plan, Circulation and Scenic Highway Element, 2008*

* Levels of service are not applied to residential streets since their primary purpose is to serve abutting lots, not carry through traffic. Levels of service normally apply to roads carrying through traffic between major trip generators and attractors

2.4 Improvement Criteria

Senate Bill 743 (SB 743) was approved in 2013 and changes the way transportation impacts are measured under the California Environmental Quality Act (CEQA). Automobile delay resulting in a level of service (LOS) is no longer considered a significant impact under CEQA. However, the County of Imperial Department of Public Works requires transportation analyses to review roadway capacity in terms of LOS to identify deficiencies and require improvements to the circulation system outside of CEQA.

Based on the County General Plan, the LOS goal for intersections and roadway segments is to operate at LOS C or better. As a result, if an intersection or roadway segment degrades from LOS C or better to LOS D or worse with the addition of project traffic, improvements would be required.

3 EXISTING CONDITIONS

This section describes the existing roadway network, peak hour traffic volumes, and operations at the study area intersections and roadway segments.

3.1 Roadway Network

State Route 86 (SR-86) is a north-south divided roadway with 2 lanes of travel provided in each direction. According to the *County's Circulation and Scenic Highway Element*, SR-86 is classified as a State Highway/Expressway. It should be noted that Caltrans relinquished this roadway between Threshill Road and Ralph Road back to the City of Imperial. As a result, this roadway will be referenced as Imperial Avenue within City limits. Parking is prohibited on both sides of the roadway. The posted speed limit is 45 miles per hour (mph).

Figure 3-1 illustrates the intersection geometrics at the study area intersections.

Appendix A provides additional details on the Caltrans relinquishment of SR-86 to the City of Imperial.

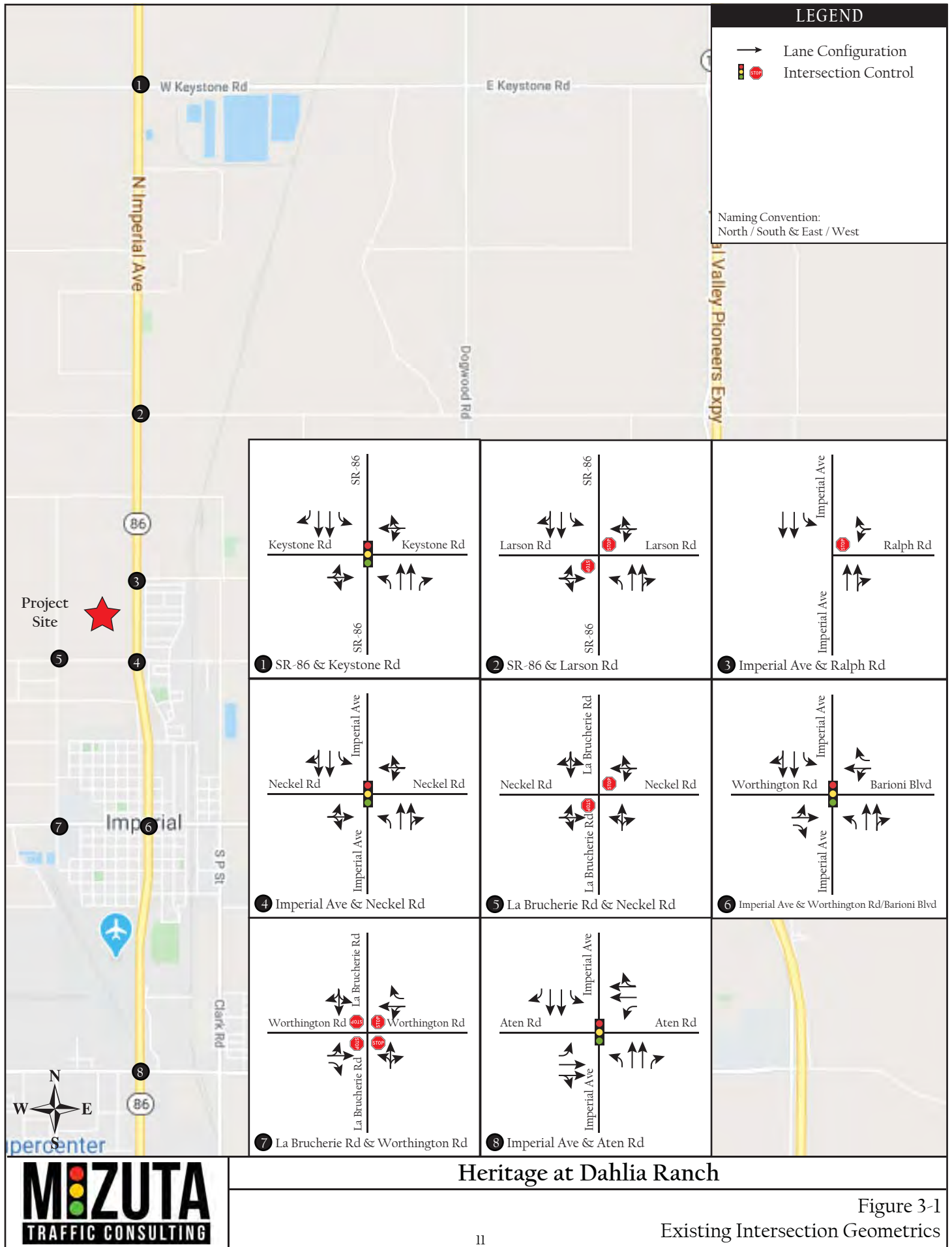
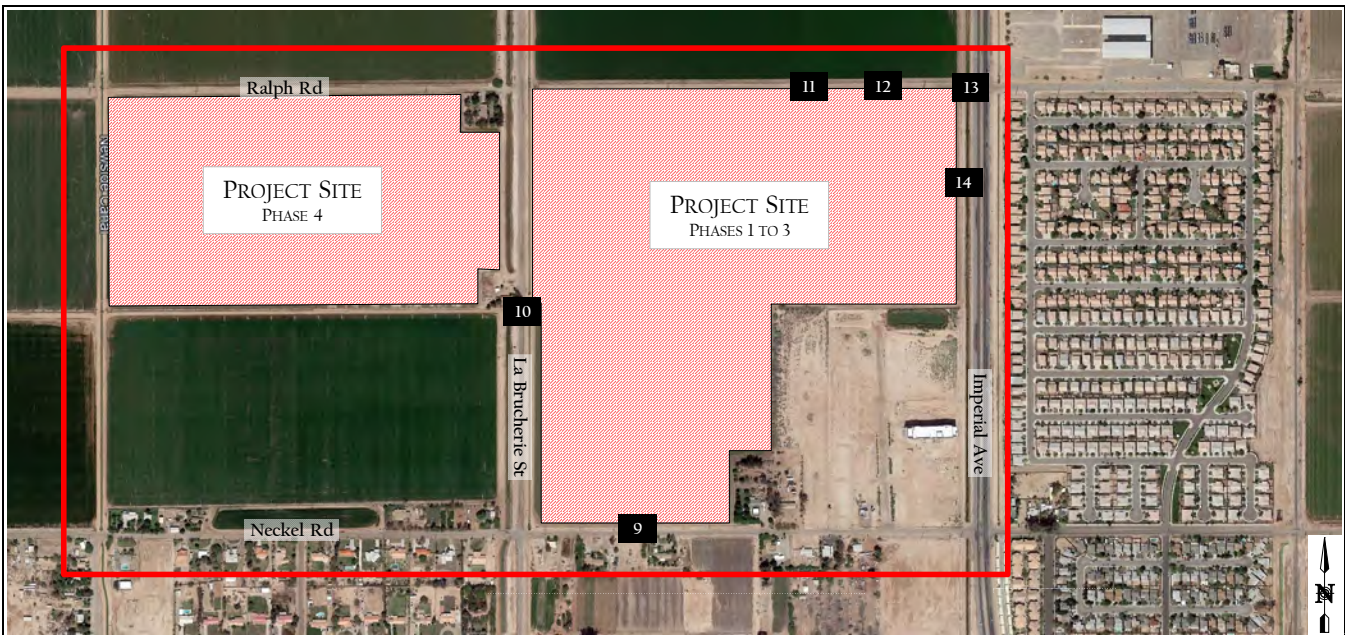

Figure 3-1
Existing Intersection Geometrics

3.2 Traffic Volumes

Existing traffic volumes at the intersections and roadway segments in the study area were obtained on October 13, 2021. The intersection counts were collected for two hours during the AM peak period (from 7:00 AM to 9:00 AM) and during the PM peak period (from 4:00 PM to 6:00 PM). Figure 3-2 illustrates the traffic volumes at the study area intersections under Existing Conditions.

Appendix B contains a copy of the existing traffic volume data sheets.



xx / yy - AM / PM Peak-Hour Turning Movement Volumes
 The naming convention for intersections is North / South & East / West

Proj Dwy & Neckel Rd		La Brucherie Rd & Proj Dwy		SFR Proj Dwy & Ralph Rd		Imperial Ave & Neckel Rd	
Does not exist		Does not exist		Does not exist		Does not exist	
Retail Proj Dwy & Ralph Rd		Imperial Ave & Proj Dwy					
Does not exist		Does not exist					



Heritage at Dahlia Ranch
 Existing Conditions Traffic Volumes

Figure 3-2a

3.3 Intersection Analysis

Table 3-1 summarizes the LOS analysis results for the study area intersections under Existing Conditions.

**Table 3-1
Existing Peak Hour Intersection LOS Summary**

#	Intersection	Traffic Control	Peak Hour	Existing Conditions	
				Delay ¹	LOS ²
1	SR-86 & Keystone Rd	Signal	AM	9.3	A
			PM	9.2	A
2	SR-86 & Larson Rd	TWSC	AM	19.3	C
			PM	24.2	C
3	Imperial Ave & Ralph Rd	TWSC	AM	18.5	C
			PM	17.9	C
4	Imperial Ave & Neckel Rd	Signal	AM	17.9	B
			PM	14.5	B
5	La Brucherie Rd & Neckel Rd	TWSC	AM	10.2	B
			PM	9.6	A
6	Imperial Ave & Worthington Rd/Barioni Blvd	Signal	AM	26.7	C
			PM	20.9	C
7	La Brucherie Rd & Worthington Rd	AWSC	AM	24.2	C
			PM	10.4	B
8	Imperial Ave & Aten Rd	Signal	AM	29.2	C
			PM	24.0	C

Notes:

OWSC: One-Way Stopped Control, TWSC: Two-Way Stopped Control, AWSC: All-Way Stopped Control

1. Delays are reported as the average control delay for the entire intersection at signalized intersections and the worst movement at unsignalized intersections.

2. LOS calculations are based on the methodology outlined in the *Highway Capacity Manual 6th Edition (HCM6)* and performed using Synchro II.

As shown in the table, all intersections and project driveways operate at LOS C or better during the weekday peak-hours.

Appendix C contains the intersection LOS worksheets.

3.4 Roadway Segment Analysis

Table 3-2 summarizes the LOS analysis results for the study area roadway segments under Existing Conditions. It should be noted that SR-86/Imperial Avenue was assumed to function as a minor arterial since it is not built to its ultimate classification as an Expressway. As shown in the table, all roadway segments function at LOS B or better.

Table 3-2
Existing Roadway Segment LOS Summary

Roadway Segment	Functional Classification ¹	Capacity (LOS E)	ADT	v/c Ratio	LOS
SR-86					
North of Keystone Rd	Minor Arterial	37,000	14,881	0.40	B
Keystone Rd to Larsen Rd	Minor Arterial	37,000	14,205	0.38	A
Larsen Rd to Ralph Rd	Minor Arterial	37,000	13,649	0.37	A
Imperial Ave					
Ralph Rd to Neckel Rd	Minor Arterial	37,000	14,056	0.38	A
Neckel Rd to Worthington Rd	Minor Arterial	37,000	18,145	0.49	B
Worthington Rd to Aten Rd	Minor Arterial	37,000	19,986	0.54	B

Notes:

1. The roadway functional classification is based off the number of lanes that currently exist.

4 PROJECT TRAFFIC

This section describes the estimated trip generation, trip distribution, and assignment of trips to the adjacent roadway network.

4.1 Trip Generation

Trip generation rates for the project were developed utilizing a combination of rates published by the *Institute of Transportation Engineers (ITE) Trip Generation Manual, 10th Edition* were applied to the project's proposed uses to determine the traffic generation characteristics of the site. Upon reviewing various land uses contained in the *ITE Trip Generation Manual*, the following list contains the land uses that were selected to represent the project with the ITE land use code shown in parenthesis:

- Single-Family Detached Housing (210)
- Multifamily Housing (Low-Rise) (220)
- Medical-Dental Office Building (720)
- Shopping Center (820)
- Supermarket (850)
- Fast-Food Restaurant with Drive-Through Window (934)
- Gas Station with Convenience Market (945)

Table 4-1 summarizes the trip generation rates used for the various land uses of the project.

Table 4-1
Trip Generation Rates

Land Use	ITE Code	Weekday Daily	AM PEAK		PM PEAK	
			Rate	In:Out Ratio	Rate	In:Out Ratio
Single-Family Detached Housing	210	9.44 trips / du	0.74	0.25 : 0.75	0.99	0.63 : 0.37
Multifamily Housing (Low-Rise)	220	7.32 trips / du	0.46	0.23 : 0.77	0.56	0.63 : 0.37
Medical-Dental Office Building	720	34.80 trips / ksf	2.78	0.78 : 0.22	3.46	0.28 : 0.72
Shopping Center	820	37.75 trips / ksf	0.94	0.62 : 0.38	3.81	0.48 : 0.52
Supermarket	850	106.78 trips / ksf	3.82	0.60 : 0.40	9.24	0.51 : 0.49
Fast-Food Restaurant w/Drive-Thru Window	934	470.95 trips / ksf	40.19	0.51 : 0.49	32.67	0.52 : 0.48
Gas Station w/Convenience Mkt	945	1440.02 trips / ksf	75.99	0.51 : 0.49	88.38	0.51 : 0.49

Notes:

ksf: 1,000 square feet, du: dwelling units

The trip rates for the project's land uses are based on the *Institute of Transportation Engineers (ITE) Trip Generation Manual, 10th Edition* unless otherwise noted by a footnote.

Table 4-2 summarizes the trip generation, by phase, for the project. Trip credits such as passby trips were applied to the proposed uses based on standard ITE trip generation reduction factors. Passby trips are trips that are already on the road network and “passing by” the project site.

The *National Cooperative Highway Research Program (NCHRP) Report 684, Enhancing Internal Trip Capture Estimation for Mixed-Use Developments* was referenced to estimate the internal capture for the project. Internal trip capture rates for the retail, restaurant, medical, and residential land uses were used for the project. Internal trips would be generated between land uses within the development, but would not be added to the external street network. It should be noted that internal capture trips would only be applied during Phase 3. Appendix D contains the internal capture worksheets.

Table 4-2
Weekday Trip Generation Summary

Land Use	Amount	ADT	AM PEAK			PM PEAK			
			In	Out	Total	In	Out	Total	
PHASE 1									
Single-Family Detached Housing	133 du	1,256	25	74	99	84	48	132	
PHASE 2									
Single-Family Detached Housing	133 du	1,256	25	74	99	84	48	132	
PHASE 3									
Multifamily Housing (Low-Rise)	200 du	1,464	22	70	92	71	41	112	
Internal Capture Trips ²		-118	-4	-23	-27	-34	-22	-56	
Retail/Commercial	35.000 ksf	1,322	21	12	33	65	69	134	
Internal Capture Trips ²		-106	-11	-8	-19	-43	-39	-82	
Passby Reduction (34%) ¹		-414	-4	-1	-5	-8	-10	-18	
Medical/Commercial	33.120 ksf	1,153	73	20	93	33	82	115	
Internal Capture Trips ¹		-93	-15	-19	-34	-7	-9	-16	
Supermarket	20.000 ksf	2,136	47	30	77	95	90	185	
Passby Reduction (36%) ¹		-769	-17	-11	-28	-35	-33	-67	
Fast-Food Restaurant w/Drive-Through Window	4.800 ksf	2,261	99	94	193	82	75	157	
Internal Capture Trips ²		-181	-37	-17	-54	-33	-47	-80	
Passby Reduction (50%) ¹		-1,040	-31	-39	-70	-25	-14	-39	
Gas Station w/Convenience Market & Car Wash	3.200 ksf	4,609	125	119	244	145	138	283	
Passby Reduction (62%) ¹		-2,858	-78	-74	-152	-90	-86	-176	
Phase 3 Total Trip Generation		12,945	387	345	732	491	495	986	
Internal Capture Trips		-498	-67	-67	-134	-117	-117	-234	
Total Driveway Trips		12,447	320	278	598	374	378	752	
Passby Reduction		-5,081	-130	-125	-255	-158	-143	-300	
Phase 3 Net New Traffic		7,366	190	153	343	216	235	452	
PHASE 4									
Single-Family Detached Housing	202 du	1,907	38	112	150	126	74	200	
PHASE 1 Net Trip Generation		1,256	25	74	99	84	48	132	
PHASES 1 & 2 Net Trip Generation		2,512	50	148	198	168	96	264	
PHASES 1 TO 3 Net Trip Generation		9,878	240	301	541	384	331	716	
PHASES 1 TO 4 Net Trip Generation		11,785	278	413	691	510	405	916	

Notes:

1. The passby trip rate is based on the average rates published in the *ITE Trip Generation Handbook, 3rd Edition*.
2. The internal capture trips are estimated based on the methodologies contained in the *NCHRP Report 684*.

As shown in the table, the entire project is forecasted to generate a net total of 11,785 daily trips with 691 AM peak-hour trips and 916 PM peak-hour trips at the project driveways on the external street network.

4.2 Trip Distribution and Assignment

The Project trip distribution was estimated based on existing travel patterns, trip distributions from other approved projects in the study area, and on logical routes to regional facilities. The following list summarizes the proposed overall trip distribution for the residential land uses:

- 20 percent to/from the north via SR-86
- 40 percent to/from the south via Imperial Avenue
- 20 percent to/from the east
 - 10 percent via Barioni Boulevard
 - 10 percent via Aten Road
- 20 percent to/from the west
 - 10 percent via Worthington Road
 - 10 percent via Aten Road

The following list summarizes the proposed overall trip distribution for the retail land uses:

- 20 percent to/from the north via SR-86
- 20 percent to/from the south via Imperial Avenue
- 40 percent to/from the east
 - 10 percent via Ralph Road
 - 10 percent via Neckel Road
 - 10 percent via Barioni Boulevard
 - 10 percent via Aten Road
- 20 percent to/from the west
 - 10 percent via Worthington Road
 - 10 percent via Aten Road

The following list summarizes the figures along with the trip distribution in each phase of the project.

- **Figure 4-1:** Residential Uses in Phase 1
- **Figure 4-2:** Residential Uses in Phase 2
- **Figure 4-3:** Residential Uses in Phase 3
- **Figure 4-4:** Commercial/Retail Uses in Phase 3
- **Figure 4-5:** Residential Uses in Phase 4

It should be noted that in Phase 3, Ralph Road is constructed and extended to the east from Imperial Avenue. As a result, some of the Phase 1 and 2 trips were reassigned to use Ralph Road to access the project site.

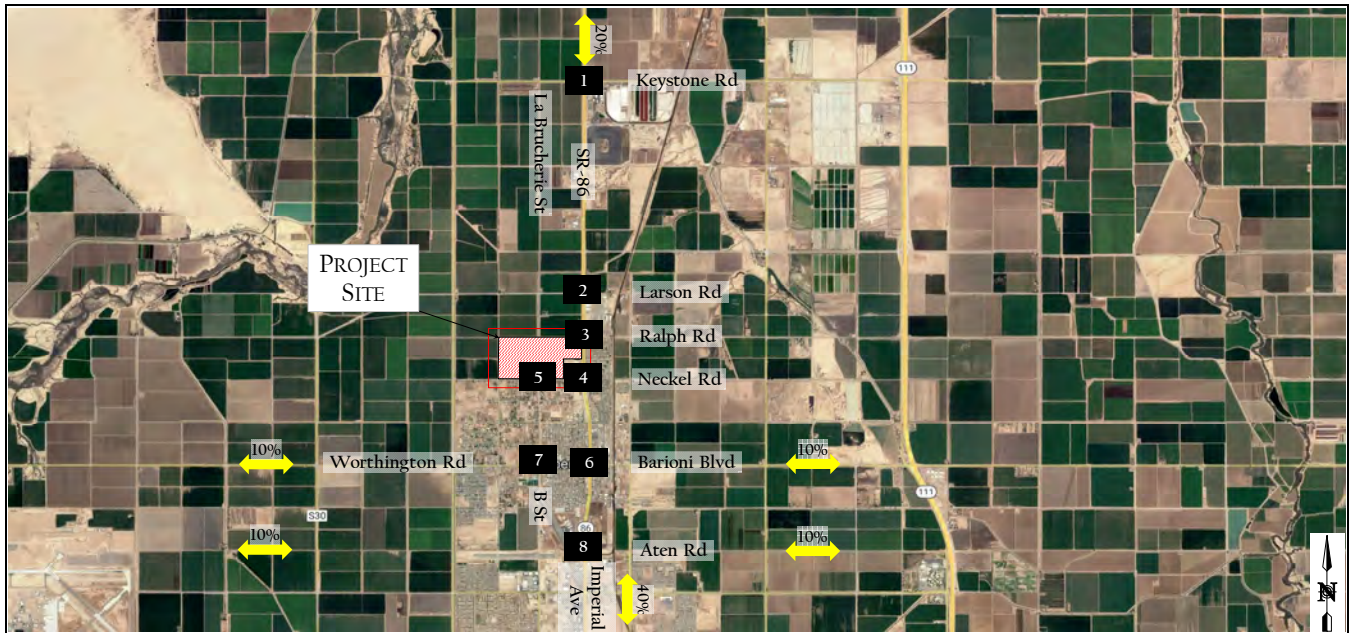

xx% / (yy%) - Enter % / (Exit %)
 The naming convention for intersections is North / South & East / West

xxx% Trip Distribution Percentage

SR-86 & Keystone Rd	SR-86 & Larsen Rd	Imperial Ave & Ralph Rd	Imperial Ave & Neckel Rd
La Brucherie Rd & Neckel Rd	Imperial Ave & Barioni Blvd / Worthington Rd		Imperial Ave & Aten Rd
		B St / La Brucherie Rd & Worthington Rd	



Heritage at Dahlia Ranch
 Phase 1 Project Trip Distribution

Figure 4-1

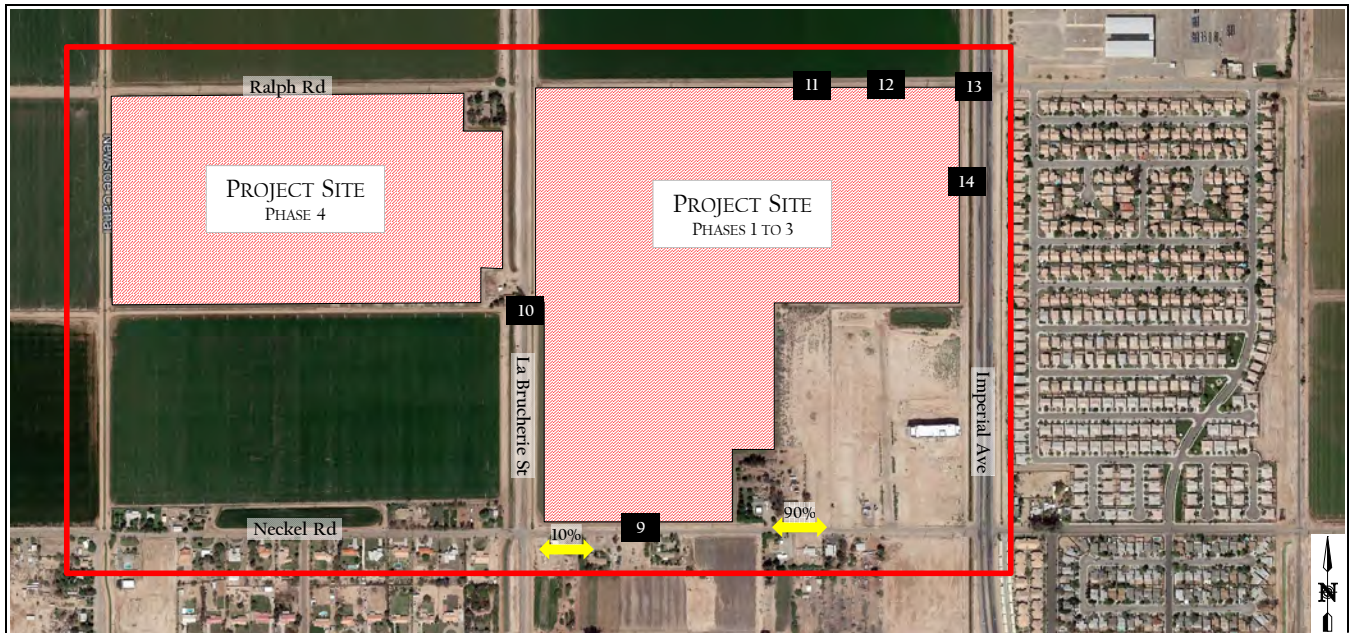

xx% / (yy%) - Enter % / (Exit %)

The naming convention for intersections is North / South & East / West

xx% Trip Distribution Percentage

Proj Dwy & Neckel Rd	La Brucherie Rd & Proj Dwy	SFR Proj Dwy & Ralph Rd	MFR Proj Dwy & Ralph Rd
<p>9</p>	Does not exist	Does not exist	Does not exist
Retail Proj Dwy & Ralph Rd	Imperial Ave & Proj Dwy		
Does not exist	Does not exist		



Heritage at Dahlia Ranch
Phase 1 Project Trip Distribution

Figure 4-1a

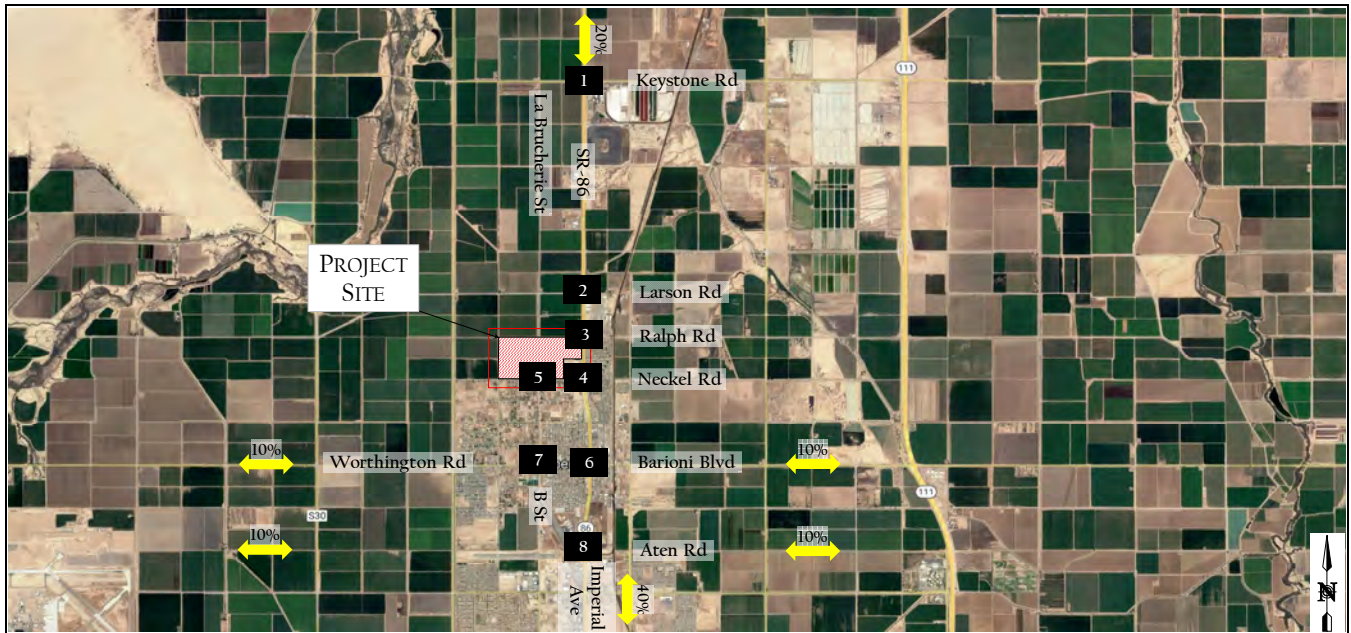

xx% / (yy%) - Enter % / (Exit %)
 The naming convention for intersections is North / South & East / West

xxx% Trip Distribution Percentage

SR-86 & Keystone Rd	SR-86 & Larsen Rd	Imperial Ave & Ralph Rd	Imperial Ave & Neckel Rd
La Brucherie Rd & Neckel Rd	Imperial Ave & Barioni Blvd / Worthington Rd		Imperial Ave & Aten Rd
		B St / La Brucherie Rd & Worthington Rd	

	<p>Heritage at Dahlia Ranch Phase 2 Project Trip Distribution</p>	<p>Figure 4-2</p>
--	--	-------------------

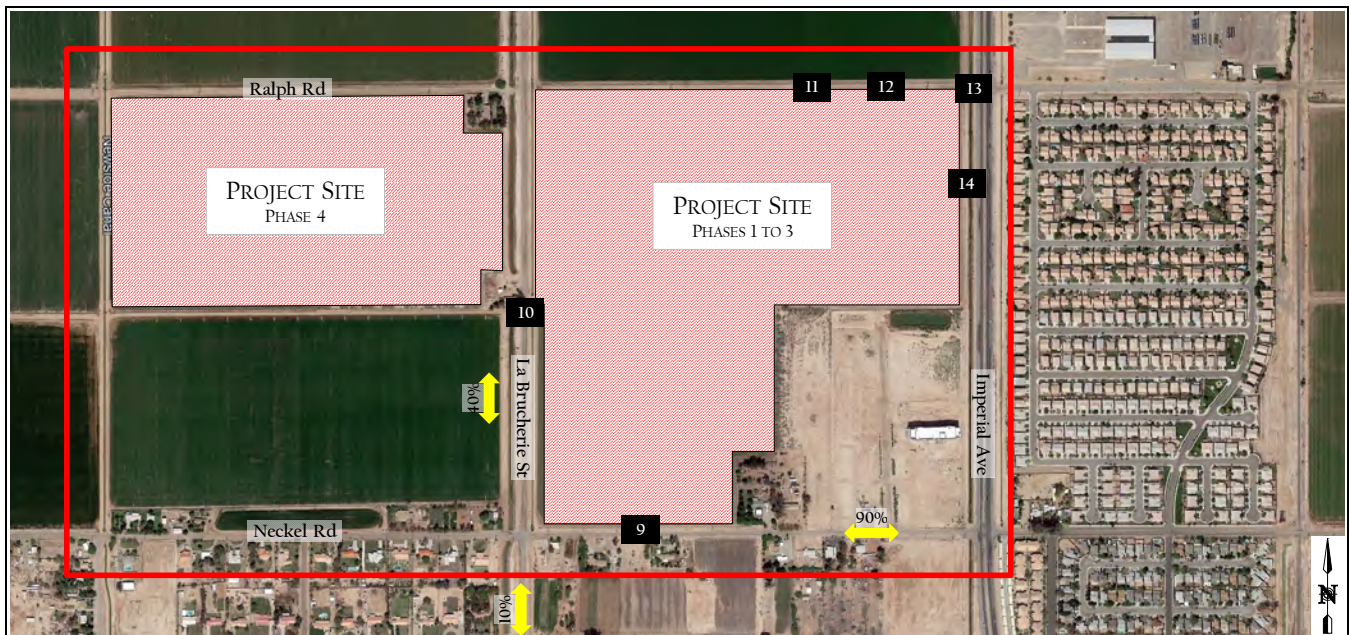

xx% / (yy%) - Enter % / (Exit %)
 The naming convention for intersections is North / South & East / West

Proj Dwy & Neckel Rd	La Brucherie Rd & Proj Dwy	SFR Proj Dwy & Ralph Rd	MFR Proj Dwy & Ralph Rd
		Does not exist	Does not exist
Retail Proj Dwy & Ralph Rd	Imperial Ave & Proj Dwy		
Does not exist	Does not exist		

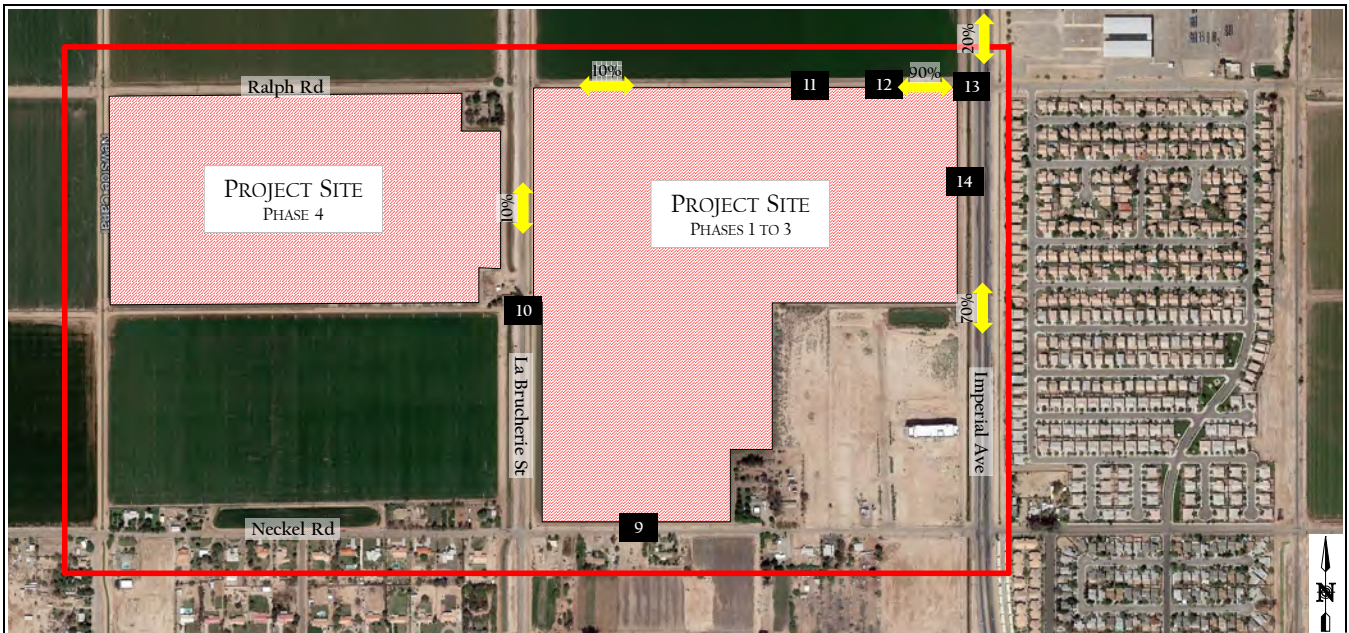

xx% / (yy%) - Enter % / (Exit %)
 The naming convention for intersections is North / South & East / West

xxx% Trip Distribution Percentage

Proj Dwy & Neckel Rd	La Brucherie Rd & Proj Dwy	SFR Proj Dwy & Ralph Rd	MFR Proj Dwy & Ralph Rd
<p style="text-align: center;">9</p>	<p style="text-align: center;">10</p>	<p style="text-align: center;">11</p>	<p style="text-align: center;">12</p>
Retail Proj Dwy & Ralph Rd	Imperial Ave & Proj Dwy		
<p style="text-align: center;">13</p>	<p style="text-align: center;">14</p>		



Heritage at Dahlia Ranch
 Phase 3 (Multi-Family) Project Trip Distribution

Figure 4-3a

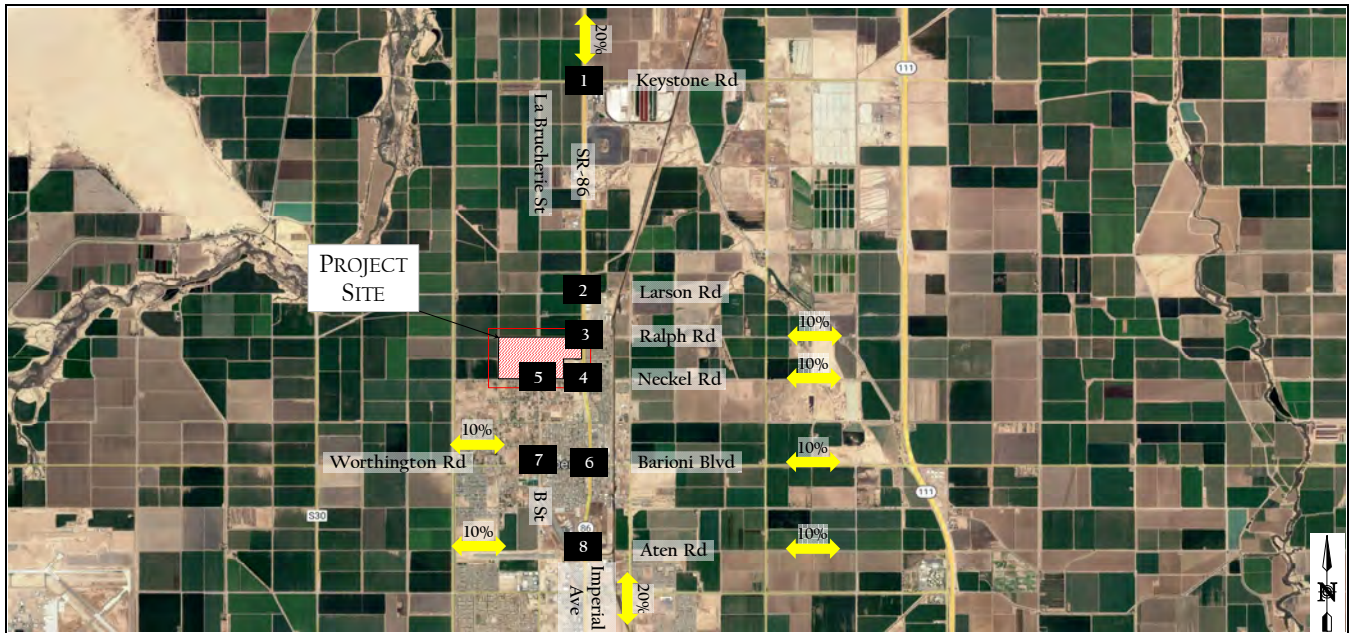

xx% / (yy%) - Enter % / (Exit %)
 The naming convention for intersections is North / South & East / West
 Trip Distribution Percentage

SR-86 & Keystone Rd	SR-86 & Larsen Rd	Imperial Ave & Ralph Rd	Imperial Ave & Neckel Rd
La Brucherie Rd & Neckel Rd	Imperial Ave & Barioni Blvd / Worthington Rd	B St / La Brucherie Rd & Worthington Rd	Imperial Ave & Aten Rd

	<p>Heritage at Dahlia Ranch Phase 3 (Commercial/Retail) Project Trip Distribution</p>	<p>Figure 4-4</p>
--	--	-------------------

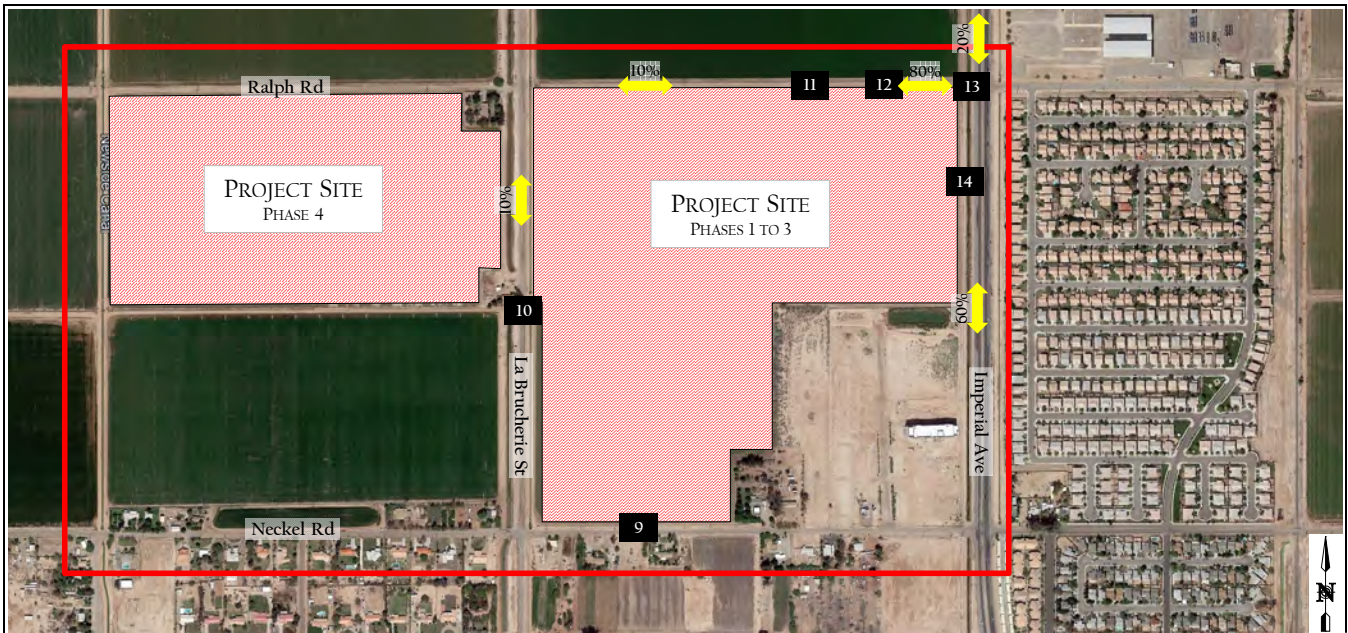

xx% / (yy%) - Enter % / (Exit %)

The naming convention for intersections is North / South & East / West

xxx% Trip Distribution Percentage

Proj Dwy & Neckel Rd		La Brucherie Rd & Proj Dwy		SFR Proj Dwy & Ralph Rd		MFR Proj Dwy & Ralph Rd	
Retail Proj Dwy & Ralph Rd		Imperial Ave & Proj Dwy					



Heritage at Dahlia Ranch
Phase 3 (Commercial/Retail) Project Trip Distribution

Figure 4-4a

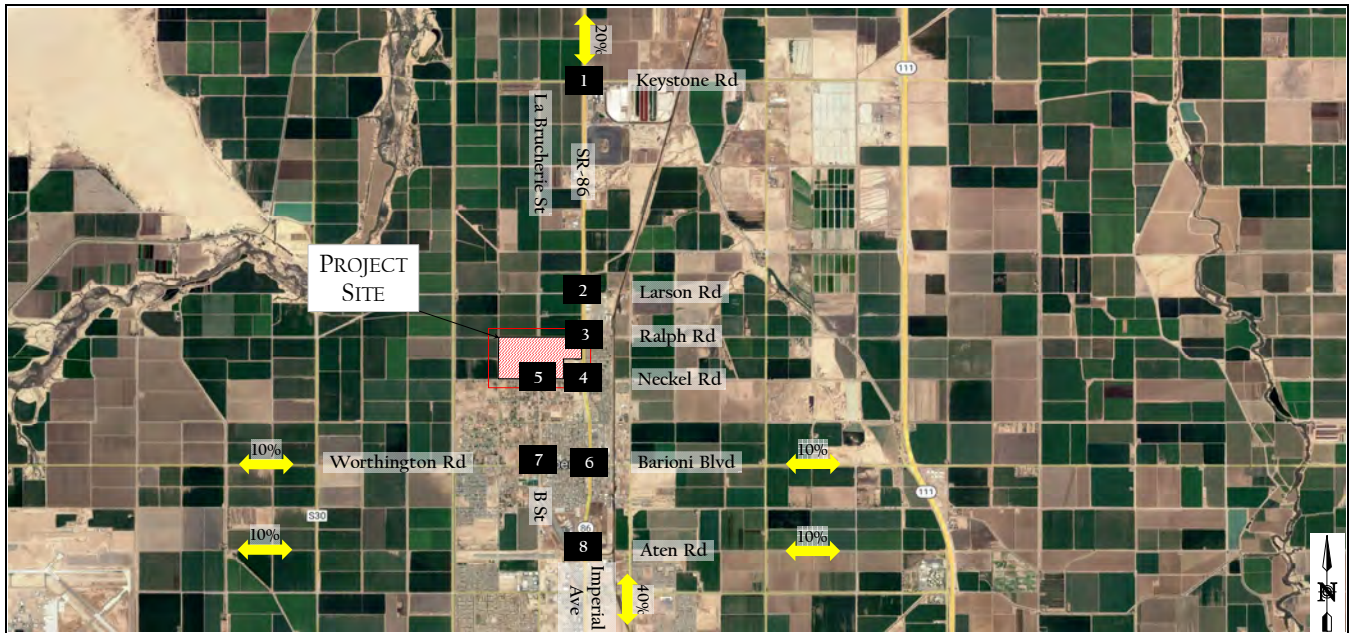

xx% / (yy%) - Enter % / (Exit %)
 The naming convention for intersections is North / South & East / West
 Trip Distribution Percentage

SR-86 & Keystone Rd	SR-86 & Larsen Rd	Imperial Ave & Ralph Rd	Imperial Ave & Neckel Rd
La Brucherie Rd & Neckel Rd	Imperial Ave & Barioni Blvd / Worthington Rd		Imperial Ave & Aten Rd

	<p>Heritage at Dahlia Ranch Phase 4 Project Trip Distribution</p>	<p>Figure 4-5</p>
--	--	-------------------

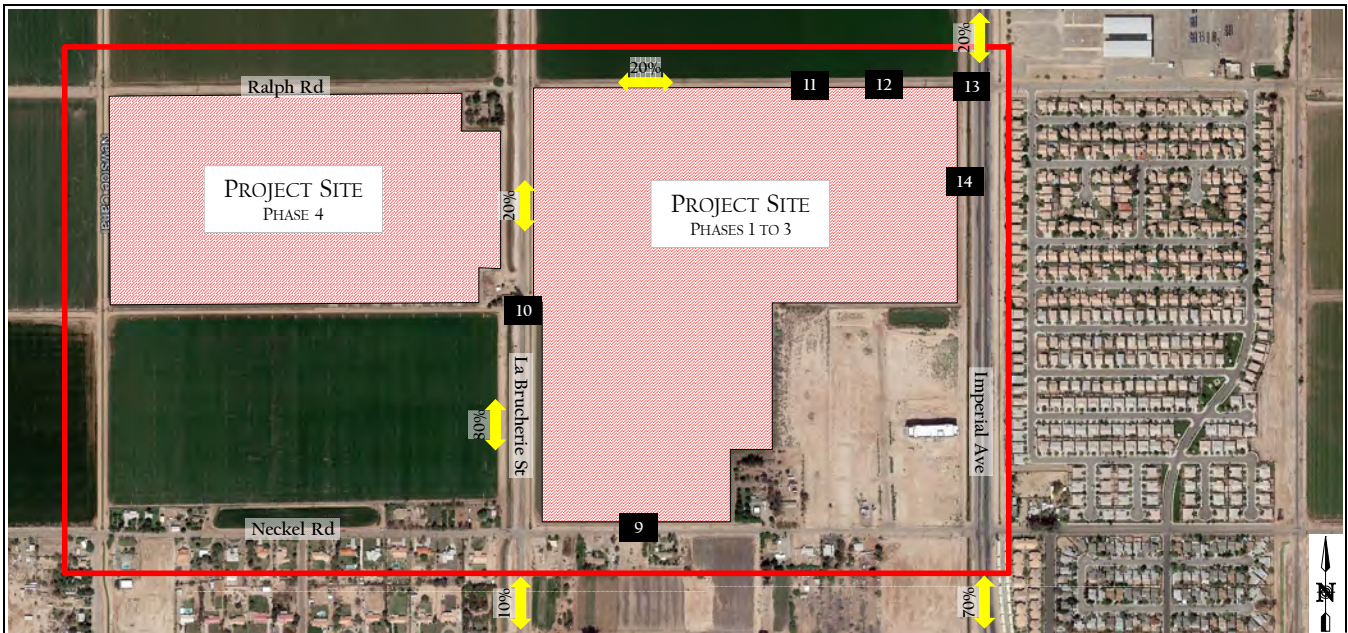

xx% / (yy%) - Enter % / (Exit %)
 The naming convention for intersections is North / South & East / West

xx% Trip Distribution Percentage

Proj Dwy & Neckel Rd	La Brucherie Rd & Proj Dwy	SFR Proj Dwy & Ralph Rd	MFR Proj Dwy & Ralph Rd
<p>← 70% / (0%)</p> <p>9</p> <p>0% / (70%) →</p>	<p>20% / (0%)</p> <p>10</p> <p>0% / (20%) ↗</p> <p>0% / (80%) ↘</p> <p>80% / (0%)</p>	<p>← 20% / (0%)</p> <p>11</p> <p>0% / (20%) →</p>	<p>← 20% / (0%)</p> <p>12</p> <p>0% / (20%) →</p>
Retail Proj Dwy & Ralph Rd	Imperial Ave & Proj Dwy		
<p>← 20% / (0%)</p> <p>13</p> <p>0% / (20%) →</p>	<p>14</p>		



Heritage at Dahlia Ranch
 Phase 4 Project Trip Distribution

Figure 4-5a

4.3 Project Trip Assignment

Based on the project trip generation and distribution, the project trips were assigned to the intersections and project driveways in the study area for the various project phases. The following list summarizes the figures along with the trip assignment in each phase of the project:

- Figure 4-6: Residential Uses in Phase 1
- Figure 4-7: Residential Uses in Phase 2
- Figure 4-8: Residential Uses in Phase 3
- Figure 4-9: Commercial/Retail Uses in Phase 3
- Figure 4-10: Residential Uses in Phase 4

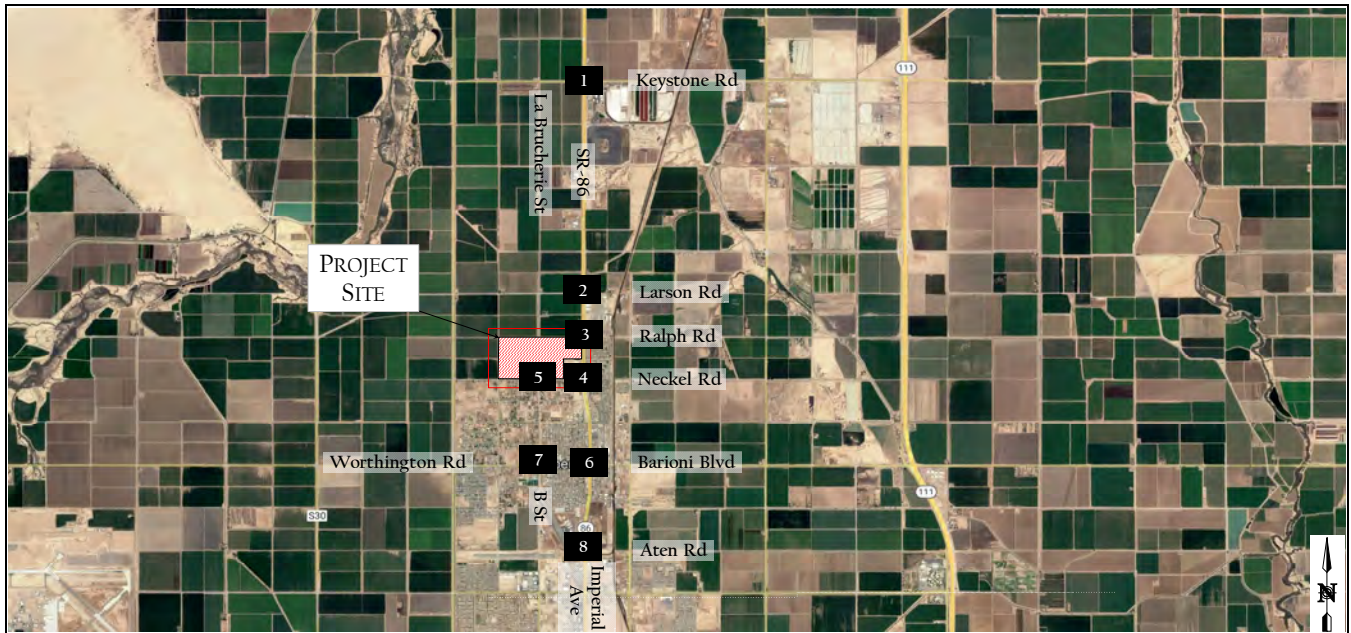

xx / yy - AM / PM Peak-Hour Turning Movement Volumes
 The naming convention for intersections is North / South & East / West

SR-86 & Keystone Rd		SR-86 & Larsen Rd		Imperial Ave & Ralph Rd		Imperial Ave & Neckel Rd	
	1		2		3		4
La Brucherie Rd & Neckel Rd		Imperial Ave & Barioni Blvd / Worthington Rd		B St / La Brucherie Rd & Worthington Rd		Imperial Ave & Aten Rd	
	5		6		7		8

	Heritage at Dahlia Ranch Phase I Project Trip Assignment	Figure 4-6
--	---	------------

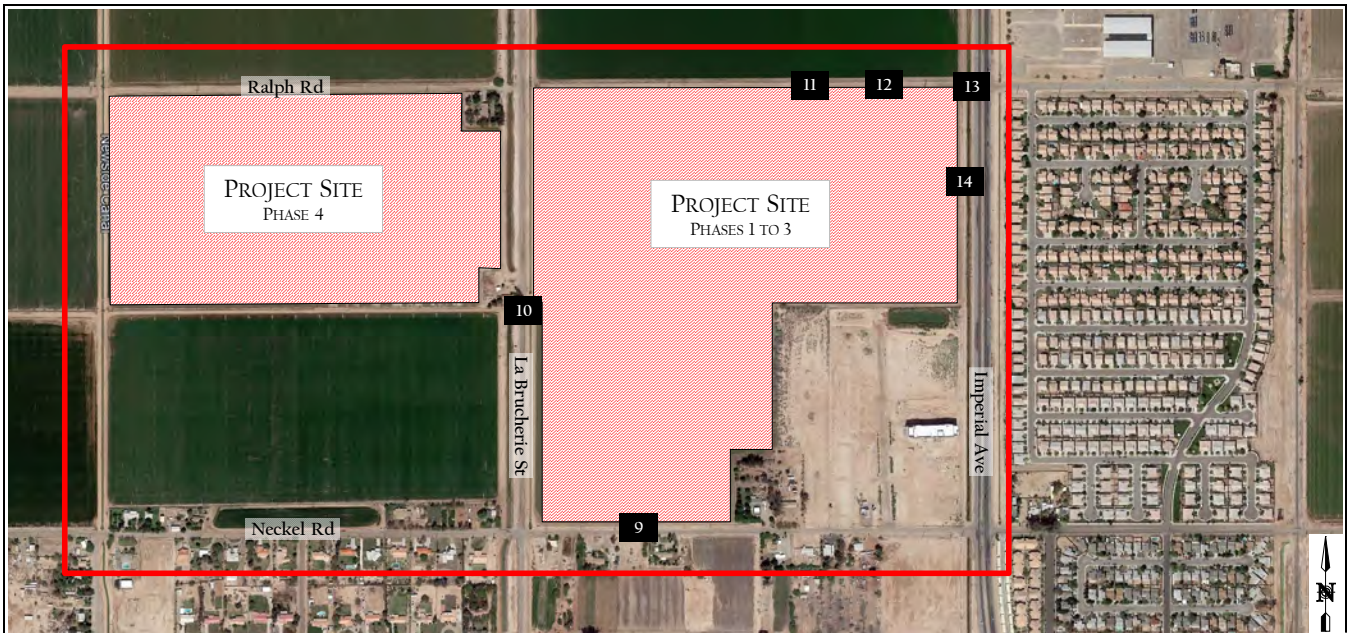

xx / yy - AM / PM Peak-Hour Turning Movement Volumes
 The naming convention for intersections is North / South & East / West

Proj Dwy & Neckel Rd	La Brucherie Rd & Proj Dwy	SFR Proj Dwy & Ralph Rd	MFR Proj Dwy & Ralph Rd
	Does not exist	Does not exist	Does not exist
Retail Proj Dwy & Ralph Rd	Imperial Ave & Proj Dwy		
Does not exist	Does not exist		



Heritage at Dahlia Ranch
 Phase 1 Project Trip Assignment

Figure 4-6a

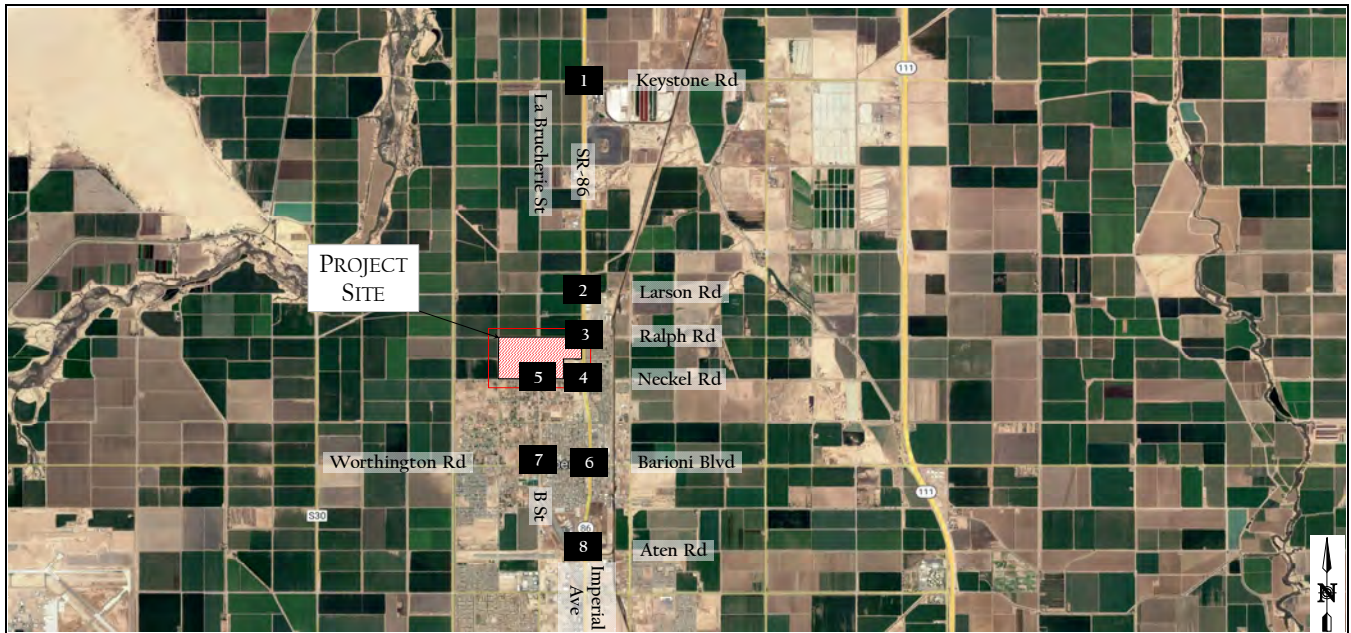

xx / yy - AM / PM Peak-Hour Turning Movement Volumes
 The naming convention for intersections is North / South & East / West

SR-86 & Keystone Rd		SR-86 & Larsen Rd		Imperial Ave & Ralph Rd		Imperial Ave & Neckel Rd			
				<th colspan="2">La Brucherie Rd & Neckel Rd</th> <th colspan="2">Imperial Ave & Barioni Blvd / Worthington Rd</th>		La Brucherie Rd & Neckel Rd		Imperial Ave & Barioni Blvd / Worthington Rd	
				<th colspan="2">B St / La Brucherie Rd & Worthington Rd</th> <th colspan="2">Imperial Ave & Aten Rd</th>		B St / La Brucherie Rd & Worthington Rd		Imperial Ave & Aten Rd	

	<p>Heritage at Dahlia Ranch Phase 2 Project Trip Assignment</p>	<p>Figure 4-7</p>
--	--	-------------------

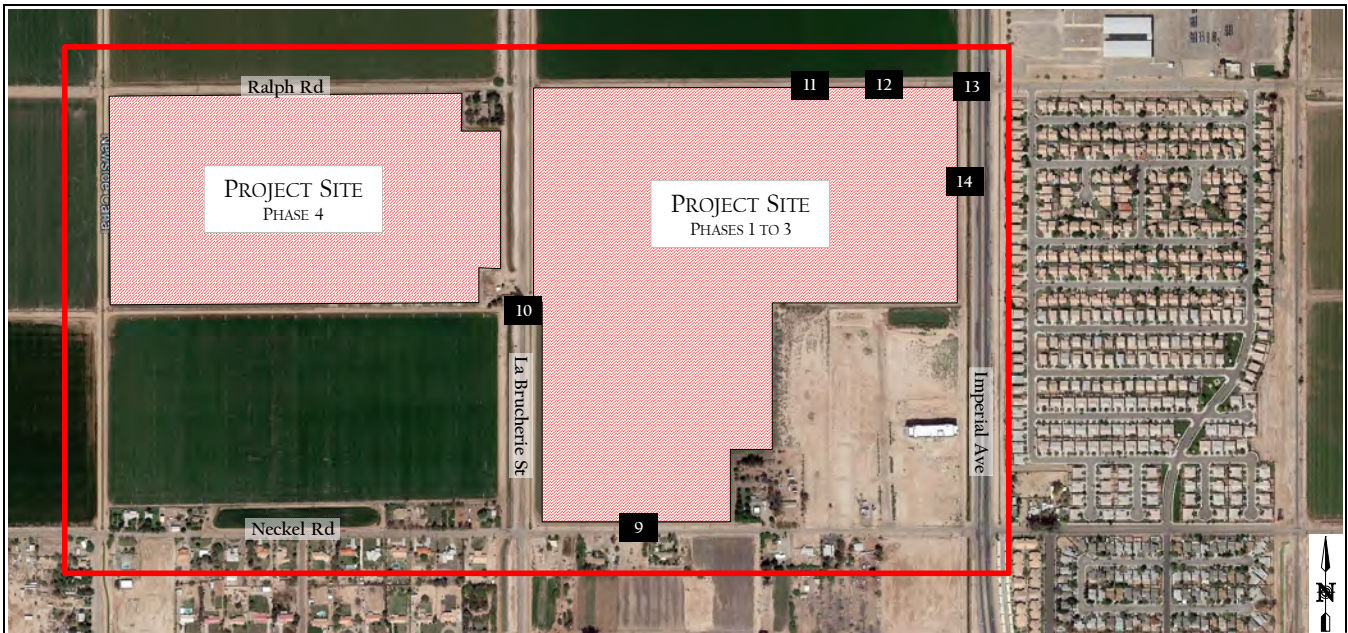

xx / yy - AM / PM Peak-Hour Turning Movement Volumes
 The naming convention for intersections is North / South & East / West

Proj Dwy & Neckel Rd	La Brucherie Rd & Proj Dwy	SFR Proj Dwy & Ralph Rd	MFR Proj Dwy & Ralph Rd
		Does not exist	Does not exist
Retail Proj Dwy & Ralph Rd	Imperial Ave & Proj Dwy		
Does not exist	Does not exist		



Heritage at Dahlia Ranch
 Phase 2 Project Trip Assignment

Figure 4-7a

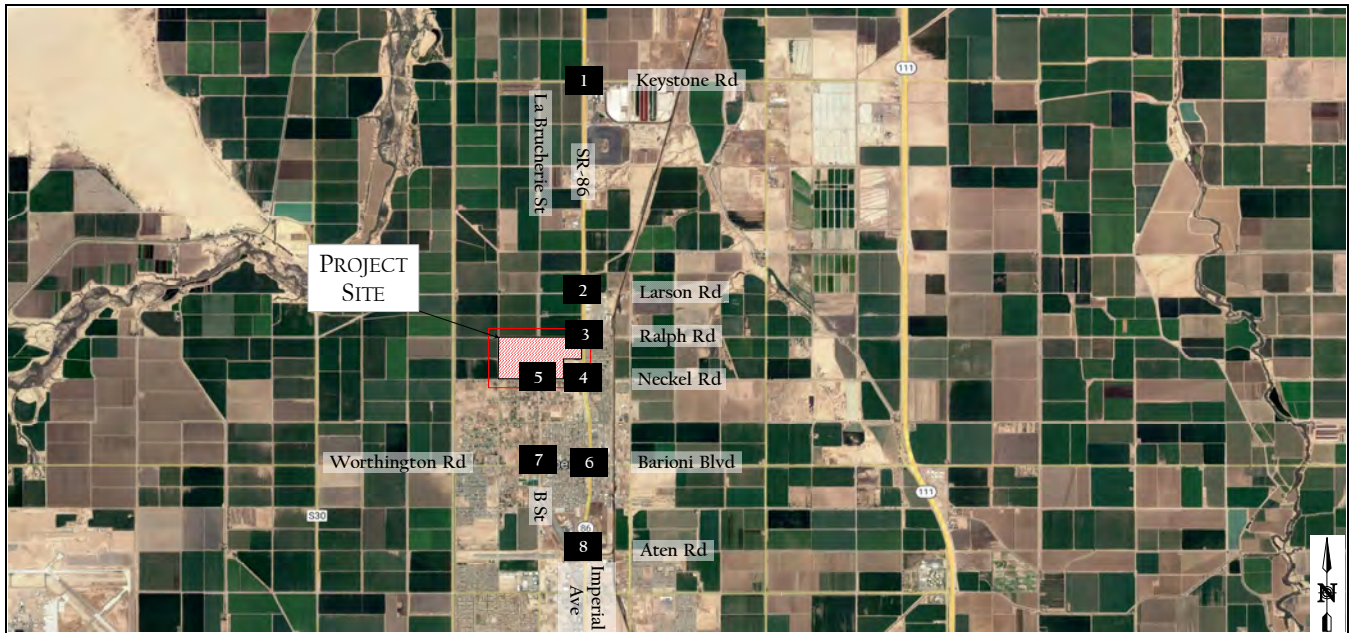

xx / yy - AM / PM Peak-Hour Turning Movement Volumes
 The naming convention for intersections is North / South & East / West

SR-86 & Keystone Rd		SR-86 & Larsen Rd		Imperial Ave & Ralph Rd		Imperial Ave & Neckel Rd	
↕ 4 / 7	1	↕ 4 / 7	2	↙ 4 / 7 ↘ 9 / 4 ↖ 33 / 13 ↗ 13 / 26	3	↕ 33 / 13	4
↔ 9 / 4		↔ 9 / 4				↔ 13 / 26	
La Brucherie Rd & Neckel Rd		Imperial Ave & Barioni Blvd / Worthington Rd		B St / La Brucherie Rd & Worthington Rd		Imperial Ave & Aten Rd	
↕ 5 / 2	5	↕ 28 / 11 ↙ 5 / 2 ↘ 2 / 4	6	↙ 5 / 2 ↘ 2 / 4	7	↙ 5 / 2 ↘ 19 / 8 ↖ 5 / 2 ↗ 2 / 4	8
↔ 2 / 4		↔ 11 / 22		↔ 2 / 4		↔ 7 / 15	

	Heritage at Dahlia Ranch Phase 3 (Multi-Family) Project Trip Assignment	Figure 4-8
--	--	------------

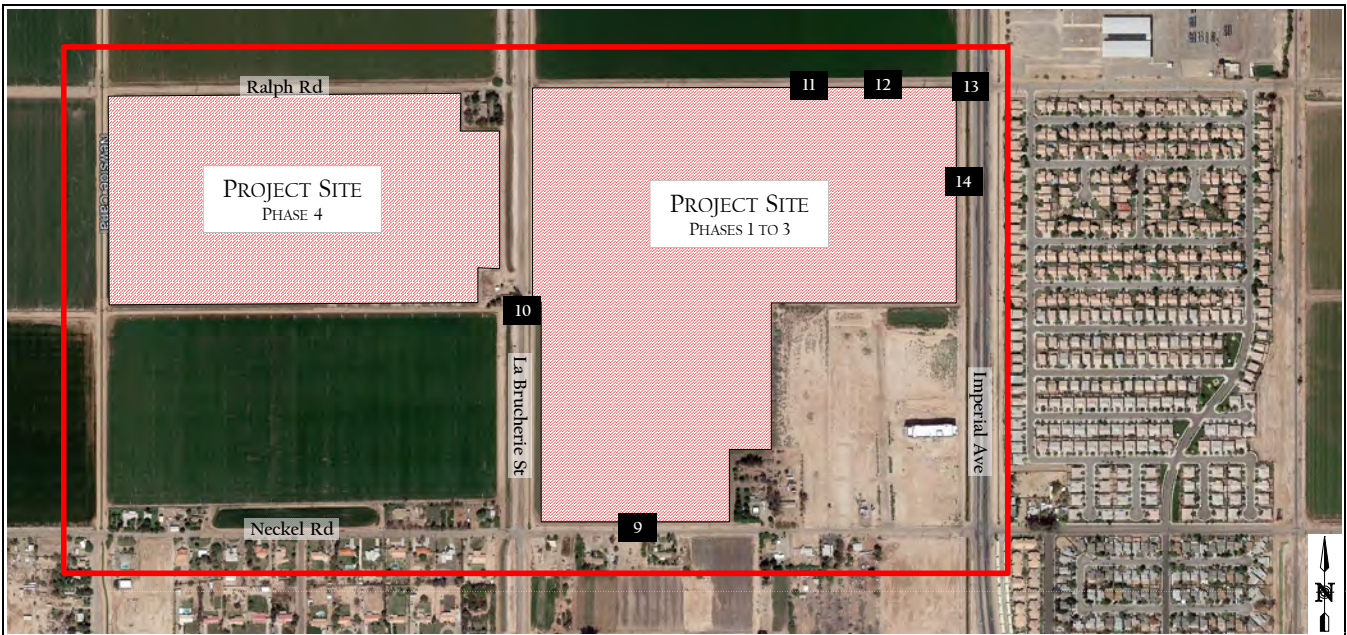

xx / yy - AM / PM Peak-Hour Turning Movement Volumes
 The naming convention for intersections is North / South & East / West

Proj Dwy & Neckel Rd	La Brucherie Rd & Proj Dwy	SFR Proj Dwy & Ralph Rd	MFR Proj Dwy & Ralph Rd
Retail Proj Dwy & Ralph Rd	Imperial Ave & Proj Dwy		



Heritage at Dahlia Ranch
 Phase 3 (Multi-Family) Project Trip Assignment

Figure 4-8a

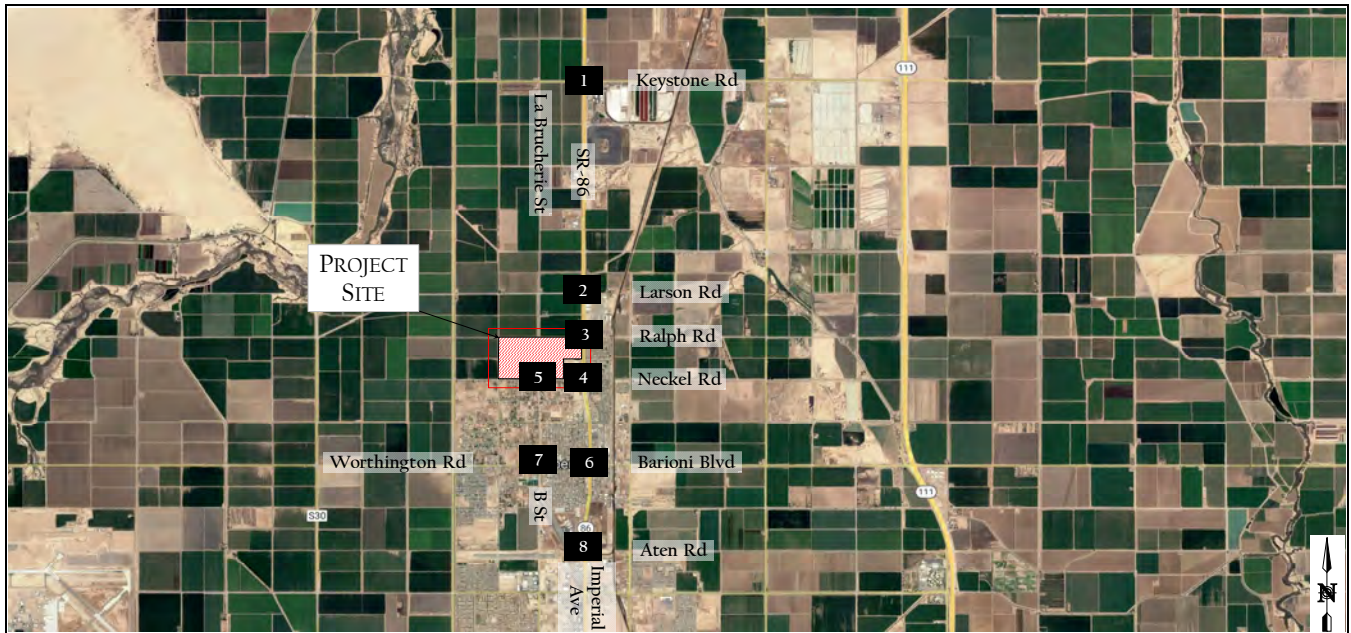

xx / yy - AM / PM Peak-Hour Turning Movement Volumes
 The naming convention for intersections is North / South & East / West

SR-86 & Keystone Rd		SR-86 & Larsen Rd		Imperial Ave & Ralph Rd		Imperial Ave & Neckel Rd	
	1		2		3		4
La Brucherie Rd & Neckel Rd		Imperial Ave & Barioni Blvd / Worthington Rd		B St / La Brucherie Rd & Worthington Rd		Imperial Ave & Aten Rd	
	5		6		7		8

	<p>Heritage at Dahlia Ranch</p> <p>Phase 3 (Commercial/Retail) Project Trip Assignment</p>	<p>Figure 4-9</p>
--	--	-------------------

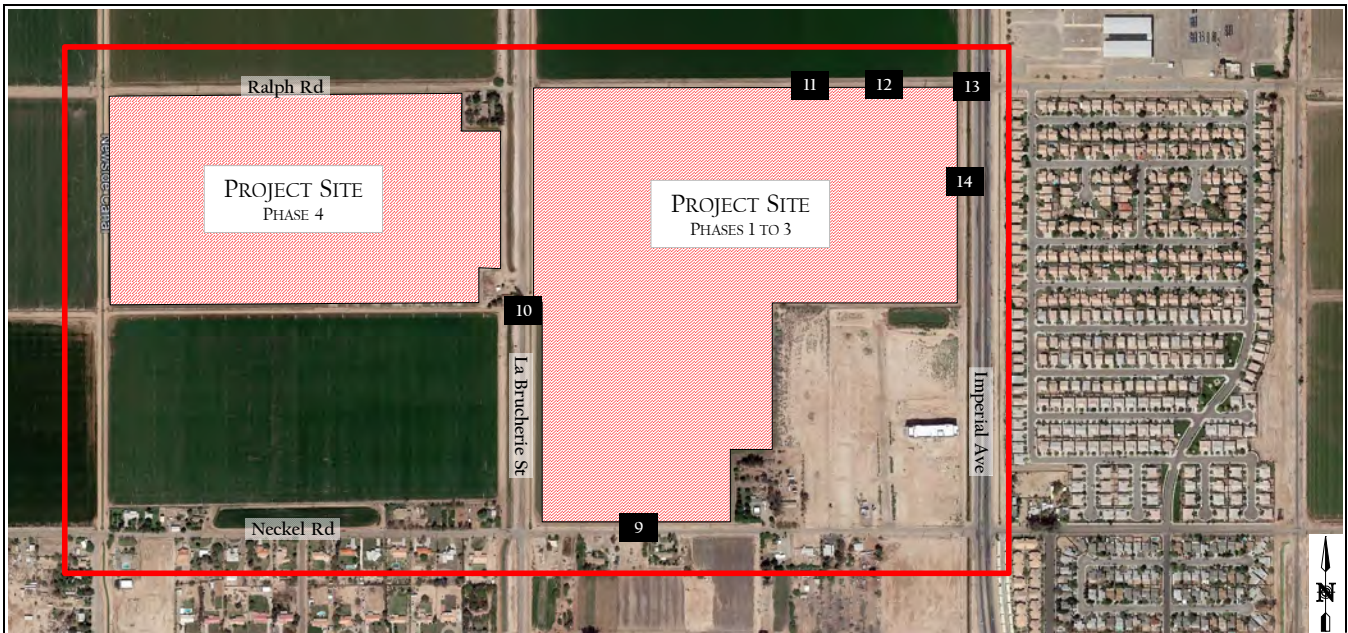

xx / yy - AM / PM Peak-Hour Turning Movement Volumes
 The naming convention for intersections is North / South & East / West

Proj Dwy & Neckel Rd	La Brucherie Rd & Proj Dwy	SFR Proj Dwy & Ralph Rd	MFR Proj Dwy & Ralph Rd
Retail Proj Dwy & Ralph Rd	Imperial Ave & Proj Dwy		



Heritage at Dahlia Ranch
 Phase 3 (Commercial/Retail) Project Trip Assignment

Figure 4-9a

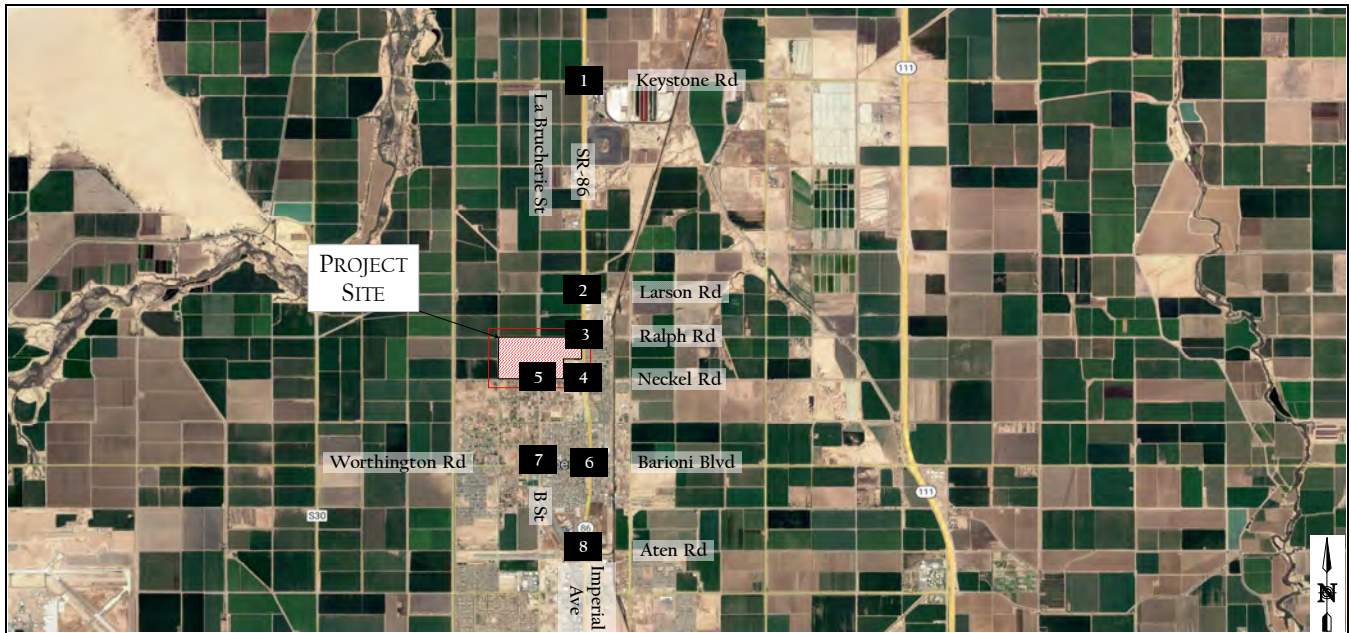

xx / yy - AM / PM Peak-Hour Turning Movement Volumes
 The naming convention for intersections is North / South & East / West

SR-86 & Keystone Rd		SR-86 & Larsen Rd		Imperial Ave & Ralph Rd		Imperial Ave & Neckel Rd	
8 / 25 ↓	1	22 / 15 ↑	2	8 / 25 ↙	3	22 / 15 ↘	4
						78 / 52 ↙	27 / 88 ↘
La Brucherie Rd & Neckel Rd		Imperial Ave & Barioni Blvd / Worthington Rd		B St / La Brucherie Rd & Worthington Rd		Imperial Ave & Aten Rd	
11 / 7 ↓	5	67 / 44 ↙	6	11 / 7 ↙	7	11 / 7 ↙	8
78 / 52 ↘	4 / 13 ↑	11 / 7 ↘	23 / 76 ↑	4 / 13 ↘	4 / 13 ↘	45 / 30 ↓	15 / 50 ↑
						4 / 13 ↘	4 / 13 ↘

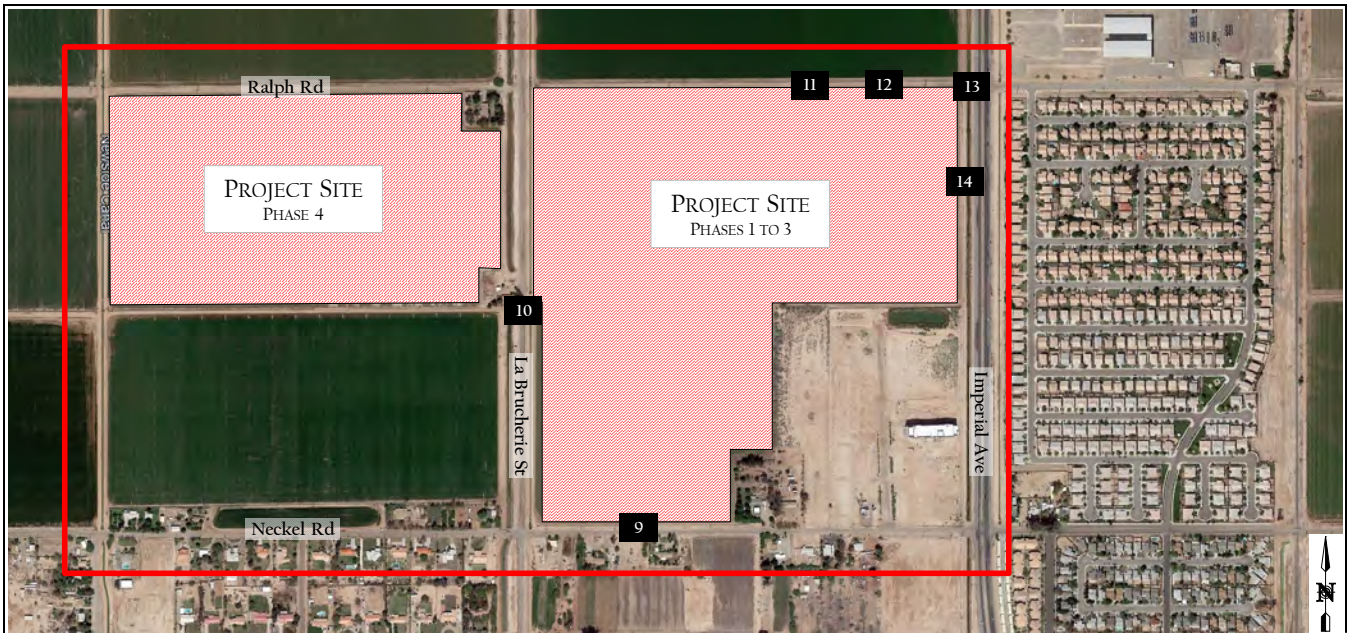

xx / yy - AM / PM Peak-Hour Turning Movement Volumes
 The naming convention for intersections is North / South & East / West

Proj Dwy & Neckel Rd	La Brucherie Rd & Proj Dwy	SFR Proj Dwy & Ralph Rd	MFR Proj Dwy & Ralph Rd
<p>← 27 / 88</p> <p>9</p> <p>78 / 52 →</p>	<p>8 / 25</p> <p>10</p> <p>22 / 15 ↘</p> <p>90 / 59 ↘</p> <p>30 / 101 ↘</p>	<p>← 8 / 25</p> <p>11</p> <p>22 / 15 →</p>	<p>← 8 / 25</p> <p>12</p> <p>22 / 15 →</p>
Retail Proj Dwy & Ralph Rd	Imperial Ave & Proj Dwy		
<p>← 8 / 25</p> <p>13</p> <p>22 / 15 →</p>	<p>14</p>		



Heritage at Dahlia Ranch
 Phase 4 Project Trip Assignment

Figure 4-10a

5 CUMULATIVE PROJECT TRAFFIC

This section summarizes the cumulative projects in the study area.

5.1 Cumulative Projects

One cumulative project will contribute traffic to the study area network and is located within the limits of the study area. A brief description of the cumulative project is summarized below.

- 1) *Clark 54* – This project consists of 241 single family dwelling units and 300 multi-family dwelling units. This project is generally bounded by Ralph Road to the north, Neckel Road to the south, Clark Road to the east, and the railroad tracks to the west. This project will be constructed over two phases with the single family homes being built by the Year 2026 and the multi-family homes being built by the Year 2028.

The total trip generation for the cumulative project shown above results in approximately 4,472 daily trips with 317 AM peak-hour trips and 407 PM peak-hour trips.

Figure 5-1 shows the location of the cumulative project. Figures 5-2 and 5-3 illustrate the traffic volumes of the cumulative project in the study area in the Year 2026 and Year 2028, respectively.

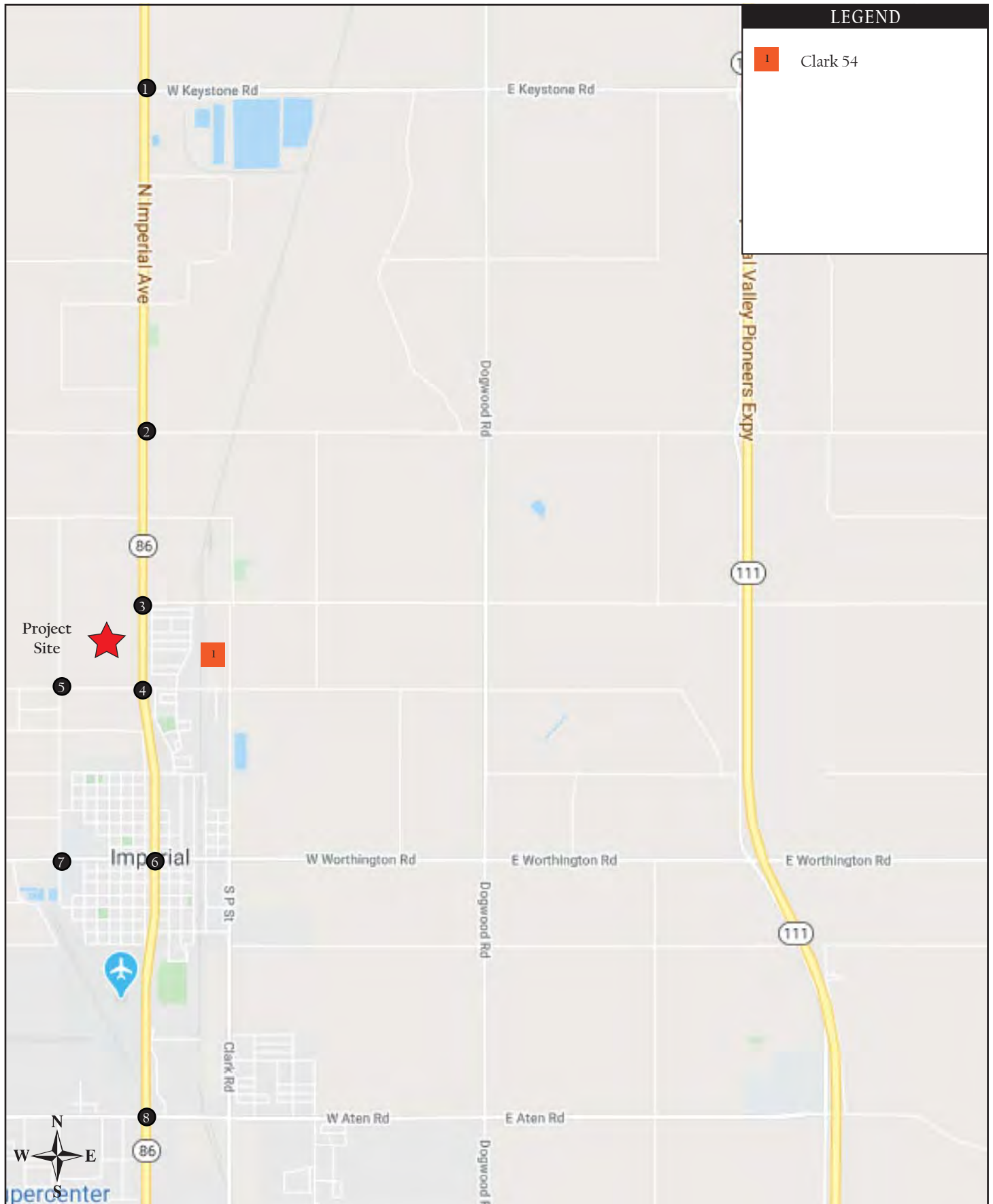

LEGEND

- 1 Clark 54



Heritage at Dahlia Ranch

Figure 5-1
Cumulative Project Location Map

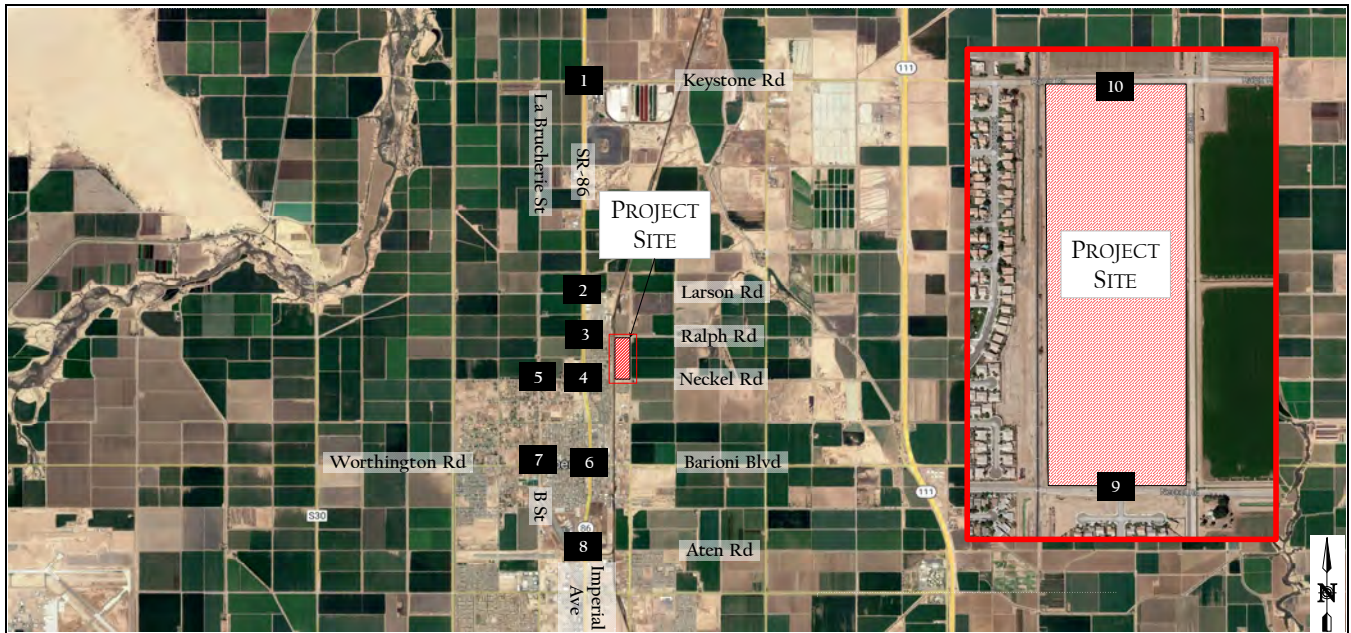

xx / yy - AM / PM Peak-Hour Turning Movement Volumes
 The naming convention for intersections is North / South & East / West

SR-86 & Keystone Rd		SR-86 & Larsen Rd		Imperial Ave & Ralph Rd		Imperial Ave & Neckel Rd	
	1		2		3		4
La Brucherie Rd & Neckel Rd		Imperial Ave & Barioni Blvd / Worthington Rd		B St / La Brucherie Rd & Worthington Rd		Imperial Ave & Aten Rd	
	5		6		7		8
Proj Dwy & Neckel Rd		Proj Dwy & Ralph Rd					
Does not exist		Does not exist					



Heritage at Dahlia Ranch
 Cumulative Project Traffic Volumes - Year 2026

Figure 5-2

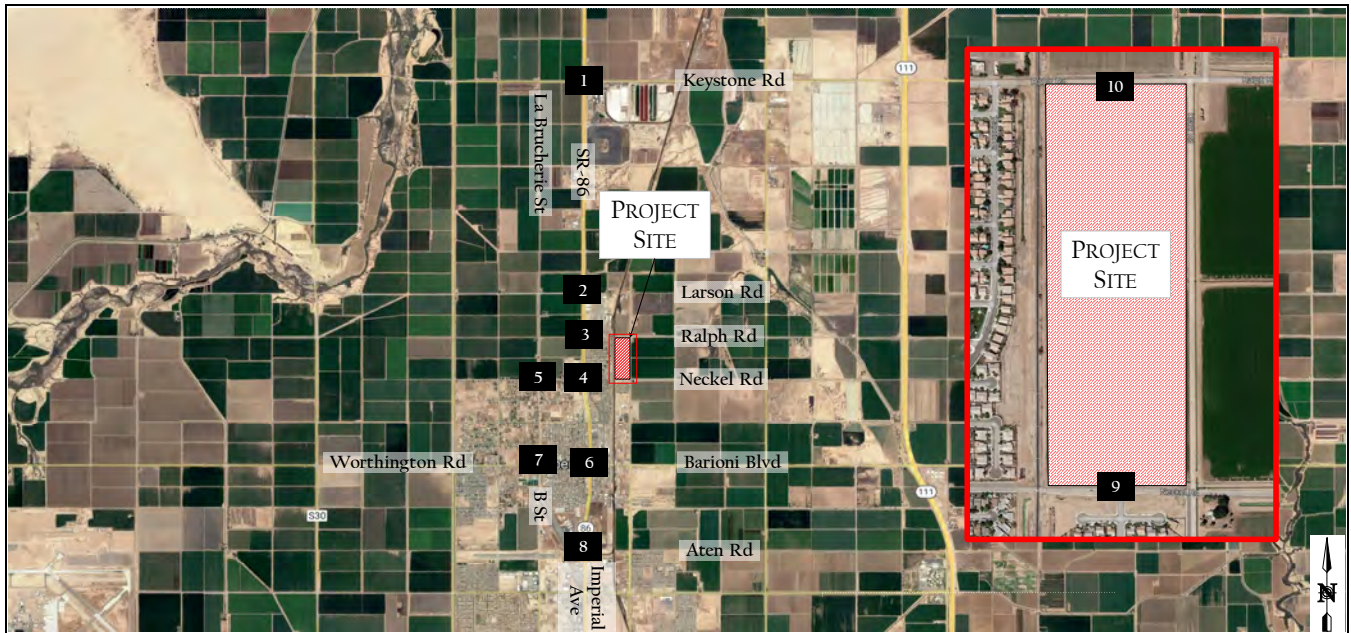

xx / yy - AM / PM Peak-Hour Turning Movement Volumes
 The naming convention for intersections is North / South & East / West

SR-86 & Keystone Rd		SR-86 & Larsen Rd		Imperial Ave & Ralph Rd		Imperial Ave & Neckel Rd	
La Brucherie Rd & Neckel Rd		Imperial Ave & Barioni Blvd / Worthington Rd		B St / La Brucherie Rd & Worthington Rd		Imperial Ave & Aten Rd	
Proj Dwy & Neckel Rd		Proj Dwy & Ralph Rd					
Does not exist		Does not exist					



Heritage at Dahlia Ranch
 Cumulative Project Traffic Volumes - Year 2028

Figure 5-3

6 OPENING YEAR 2023

This section summarizes the operations at the study area intersections, roadway segments, and project driveways with the addition of the Phase 1 project traffic in the anticipated year of opening in 2023.

6.1 Roadway Network

No changes to the existing roadway network are proposed under this condition except at the project driveway along Neckel Road. The Project will construct an eastbound left-turn lane along Neckel Road. **Figure 6-1** illustrates the intersection geometrics with the addition of the Phase 1 Project traffic.

6.2 Traffic Volumes

The Opening Year 2023 Baseline Conditions traffic volumes were developed by applying a regional growth factor and including the cumulative traffic volumes. According to the *Southern California Association of Governments' (SCAG) Profile of Imperial County Report, May 2019*, the population of Imperial County grew by 48,263 people between 2000 and 2018, which corresponds to an annual growth rate of 1.4 percent. This growth rate was applied to the existing traffic volumes for two years to estimate the Year 2023 baseline conditions. **Appendix E** contains of the *SCAG Profile of Imperial County Report*.

Figure 6-2 illustrates the Opening Year 2023 Baseline traffic volumes. **Figure 6-3** illustrates the Opening Year 2023 Plus Phase 1 Project traffic volumes.

6.3 Intersection Analysis

Table 6-1 displays the LOS analysis results for the study intersections and project driveways under Opening Year 2023 Baseline and Plus Phase 1 Project conditions.

Appendix C contains the intersection LOS worksheets.

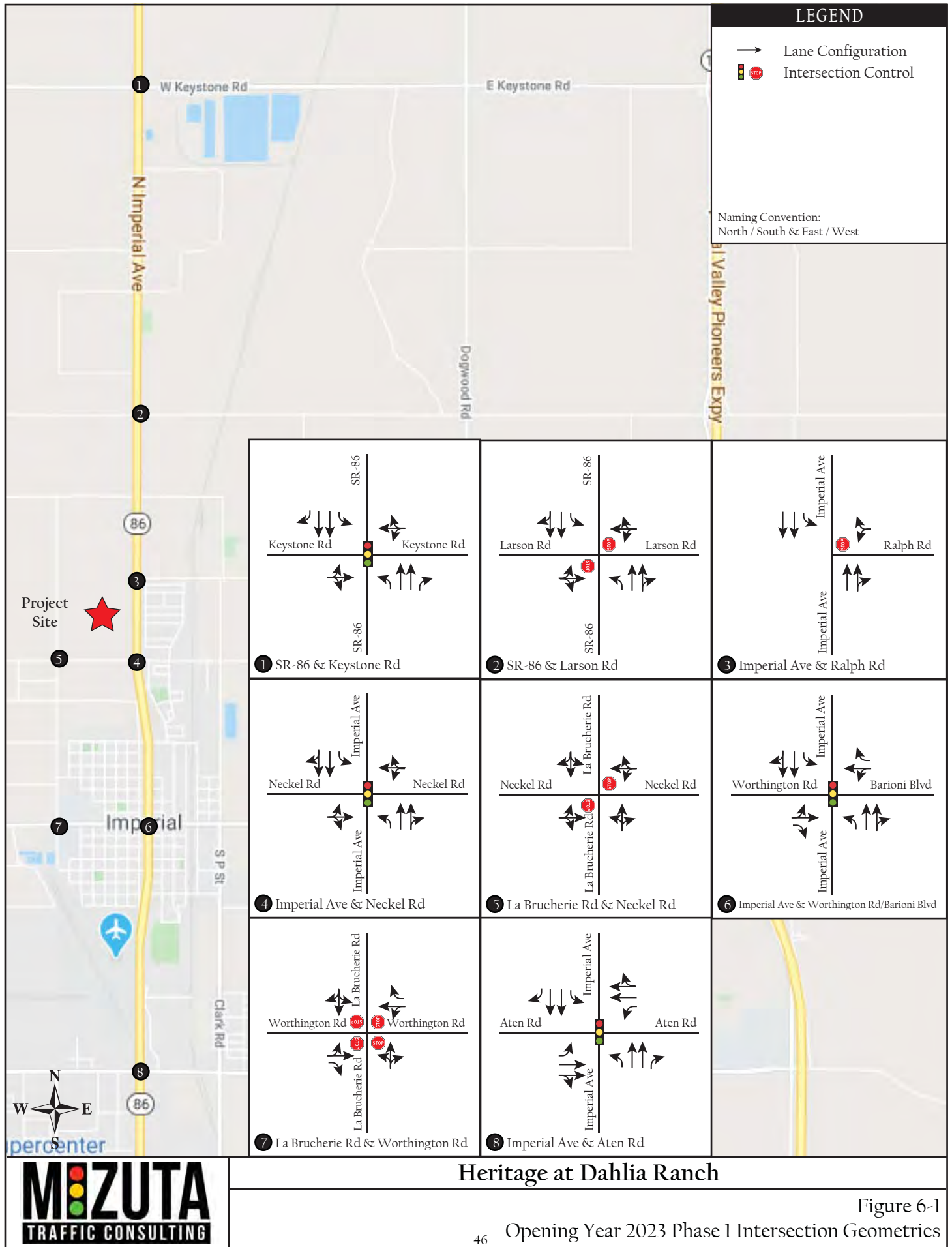

LEGEND

- Lane Configuration
- 🛑 Intersection Control

Naming Convention:
North / South & East / West

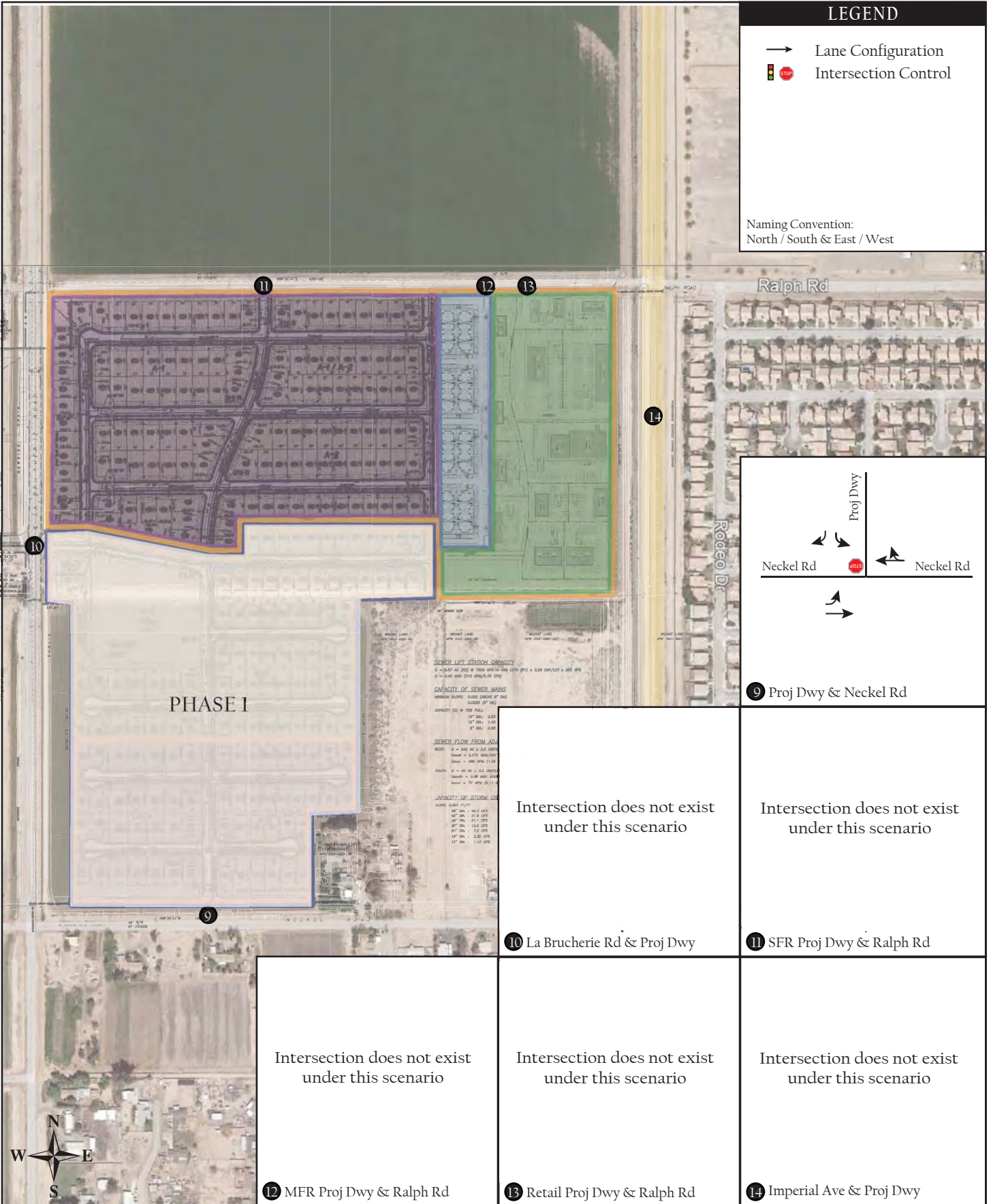

Heritage at Dahlia Ranch

Figure 6-1a

Opening Year 2023 Phase I Intersection Geometrics

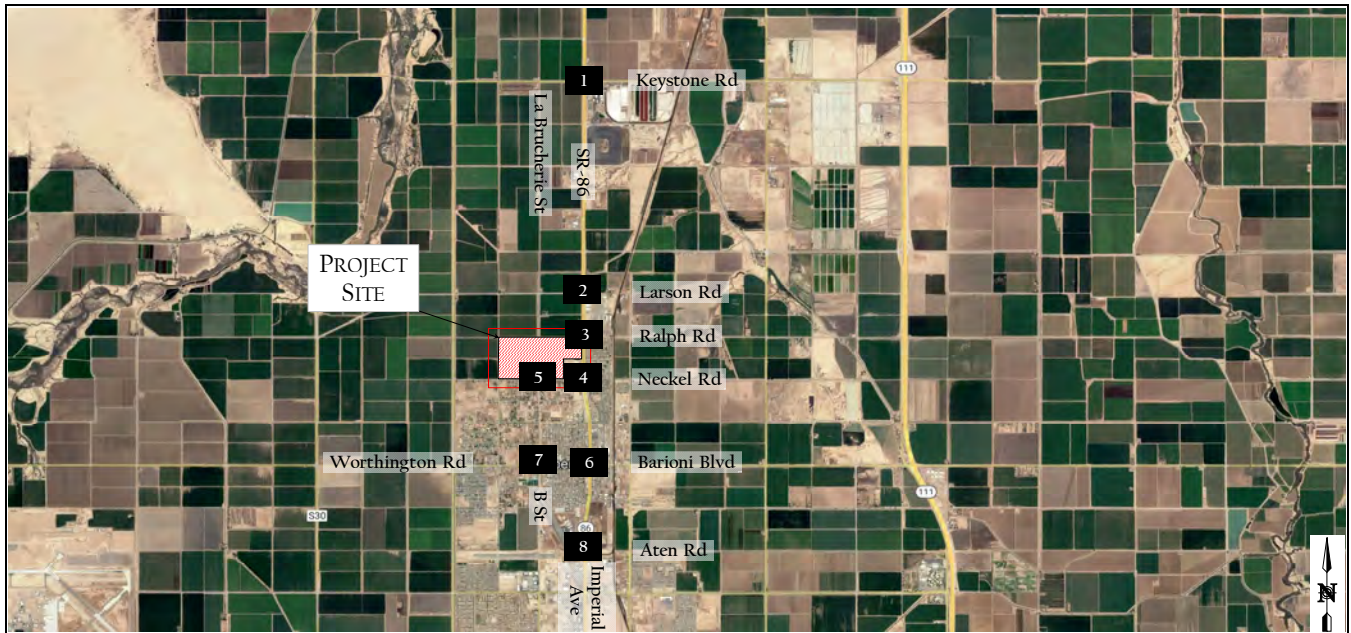

xx / yy - AM / PM Peak-Hour Turning Movement Volumes
 The naming convention for intersections is North / South & East / West

SR-86 & Keystone Rd		SR-86 & Larsen Rd		Imperial Ave & Ralph Rd		Imperial Ave & Neckel Rd	
37 / 34 512 / 542 45 / 52 42 / 37 24 / 27 19 / 33	1	7 / 17 517 / 578 1 / 6 5 / 5 2 / 0 1 / 7	2	500 / 542 20 / 30 23 / 10 59 / 20	3	31 / 28 511 / 496 14 / 29 56 / 46 64 / 20 142 / 82	4
33 / 41 33 / 12 11 / 20 19 / 10 439 / 523 49 / 26	1	20 / 6 3 / 4 2 / 0 0 / 1 506 / 561 1 / 7	2	484 / 562 41 / 30	3	34 / 12 43 / 26 12 / 4 8 / 11 442 / 555 65 / 83	4
La Brucherie Rd & Neckel Rd		Imperial Ave & Barioni Blvd / Worthington Rd		B St / La Brucherie Rd & Worthington Rd		Imperial Ave & Aten Rd	
1 / 7 2 / 5 1 / 0 0 / 1 44 / 44 60 / 23	5	56 / 63 630 / 593 39 / 27 77 / 51 132 / 112 54 / 54	6	64 / 24 31 / 5 106 / 37 77 / 34 301 / 215 11 / 27	7	375 / 209 670 / 538 142 / 112 141 / 122 299 / 288 131 / 178	8
4 / 2 41 / 38 23 / 8 7 / 5 6 / 6 42 / 10	5	70 / 48 136 / 74 212 / 105 93 / 112 465 / 666 50 / 14	6	61 / 26 390 / 187 119 / 33 0 / 1 1 / 0	7	186 / 189 337 / 276 63 / 68 61 / 78 343 / 664 67 / 149	8

	<p>Heritage at Dahlia Ranch</p> <p>Opening Year 2023 Baseline Traffic Volumes</p>	<p>Figure 6-2</p>
--	---	-------------------

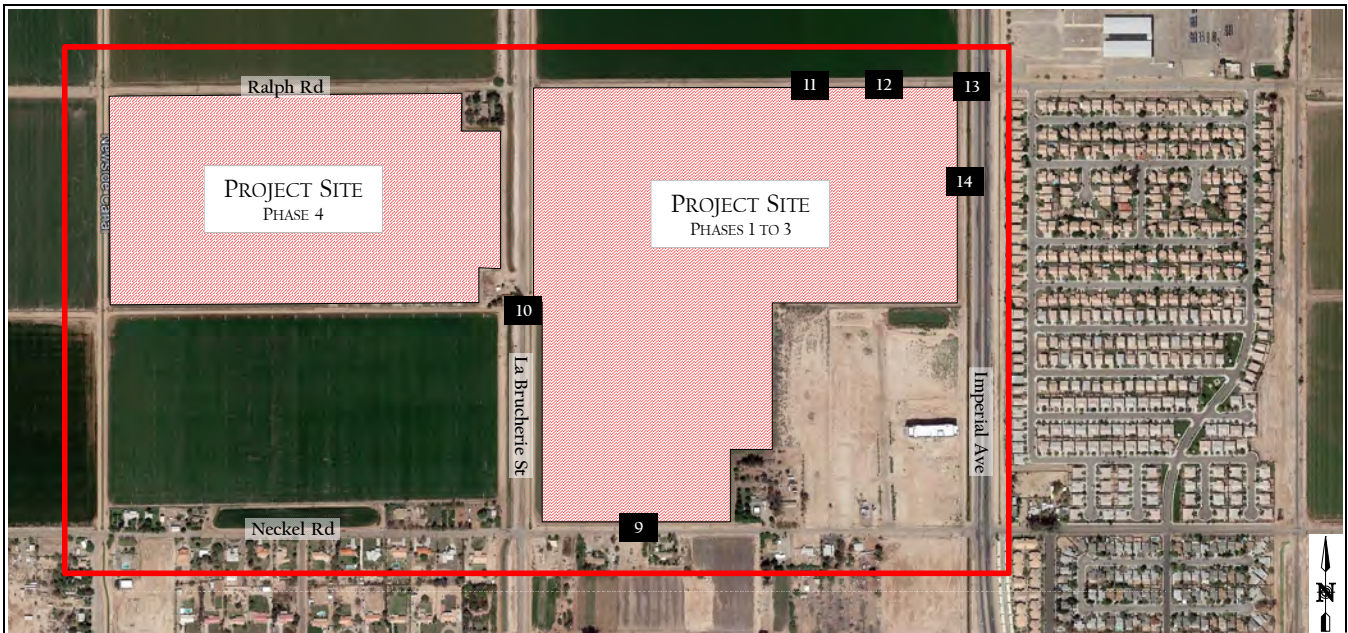

xx / yy - AM / PM Peak-Hour Turning Movement Volumes
 The naming convention for intersections is North / South & East / West

Proj Dwy & Neckel Rd	La Brucherie Rd & Proj Dwy	SFR Proj Dwy & Ralph Rd	MFR Proj Dwy & Ralph Rd
Does not exist	Does not exist	Does not exist	Does not exist
Retail Proj Dwy & Ralph Rd	Imperial Ave & Proj Dwy		
Does not exist	Does not exist		



Heritage at Dahlia Ranch
 Opening Year 2023 Baseline Traffic Volumes

Figure 6-2a

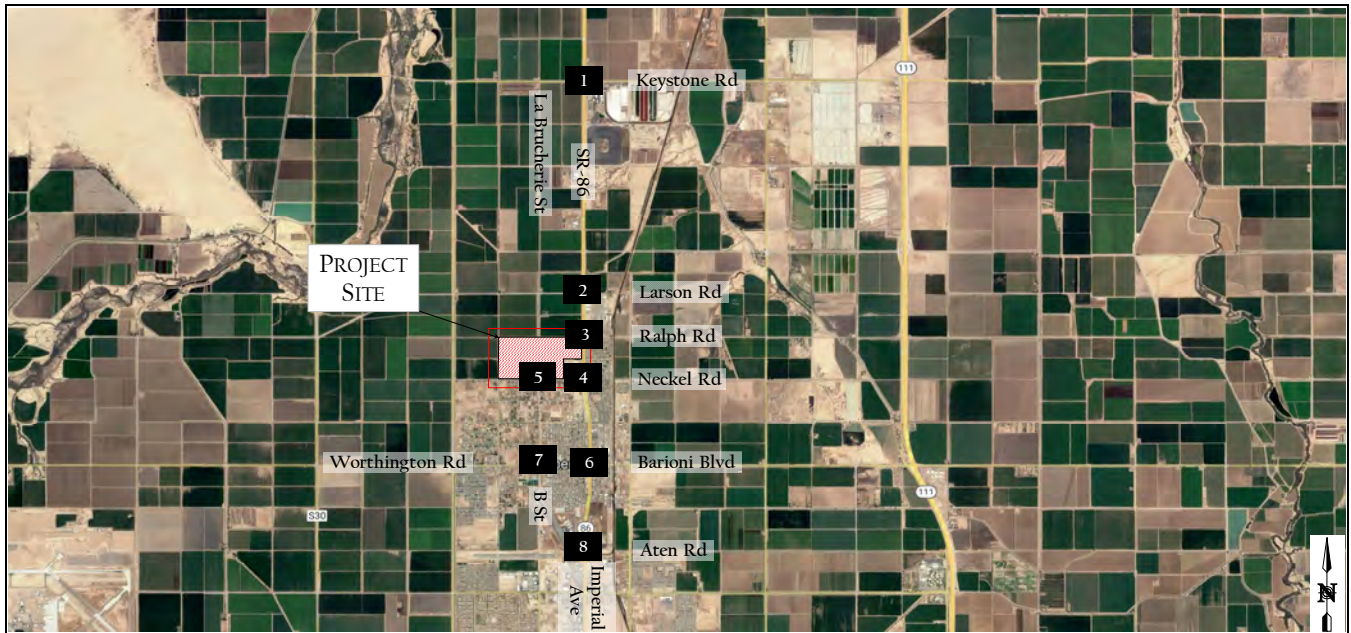

xx / yy - AM / PM Peak-Hour Turning Movement Volumes
 The naming convention for intersections is North / South & East / West

SR-86 & Keystone Rd		SR-86 & Larson Rd		Imperial Ave & Ralph Rd		Imperial Ave & Neckel Rd	
37 / 34 517 / 559 45 / 52 42 / 37 24 / 27 19 / 33		7 / 17 522 / 595 1 / 6 5 / 5 2 / 0 1 / 7		505 / 559 20 / 30 23 / 10 59 / 20		36 / 45 511 / 496 14 / 29 56 / 46 64 / 20 142 / 82	
33 / 41 33 / 12 11 / 20 19 / 10 454 / 533 49 / 26		20 / 6 3 / 4 2 / 0 0 / 1 521 / 571 1 / 7		499 / 572 41 / 30		49 / 22 43 / 26 64 / 38 26 / 70 442 / 555 65 / 83	
La Brucherie Rd & Neckel Rd		Imperial Ave & Barioni Blvd / Worthington Rd		B St / La Brucherie Rd & Worthington Rd		Imperial Ave & Aten Rd	
1 / 7 2 / 5 1 / 0 0 / 1 44 / 44 67 / 28		56 / 63 674 / 622 46 / 32 80 / 59 132 / 112 54 / 54		71 / 29 31 / 5 106 / 37 77 / 34 301 / 215 11 / 27		382 / 214 700 / 557 149 / 117 144 / 130 299 / 288 131 / 178	
4 / 2 41 / 38 23 / 8 7 / 5 6 / 6 45 / 18		70 / 48 136 / 74 212 / 105 93 / 112 480 / 716 50 / 14		64 / 34 390 / 187 119 / 33 0 / 1 1 / 0		189 / 197 337 / 276 63 / 68 61 / 78 353 / 698 67 / 149	

	<p>Heritage at Dahlia Ranch</p> <p>Opening Year 2023 Plus Phase I Project Traffic Volumes</p>	<p>Figure 6-3</p>
--	---	-------------------

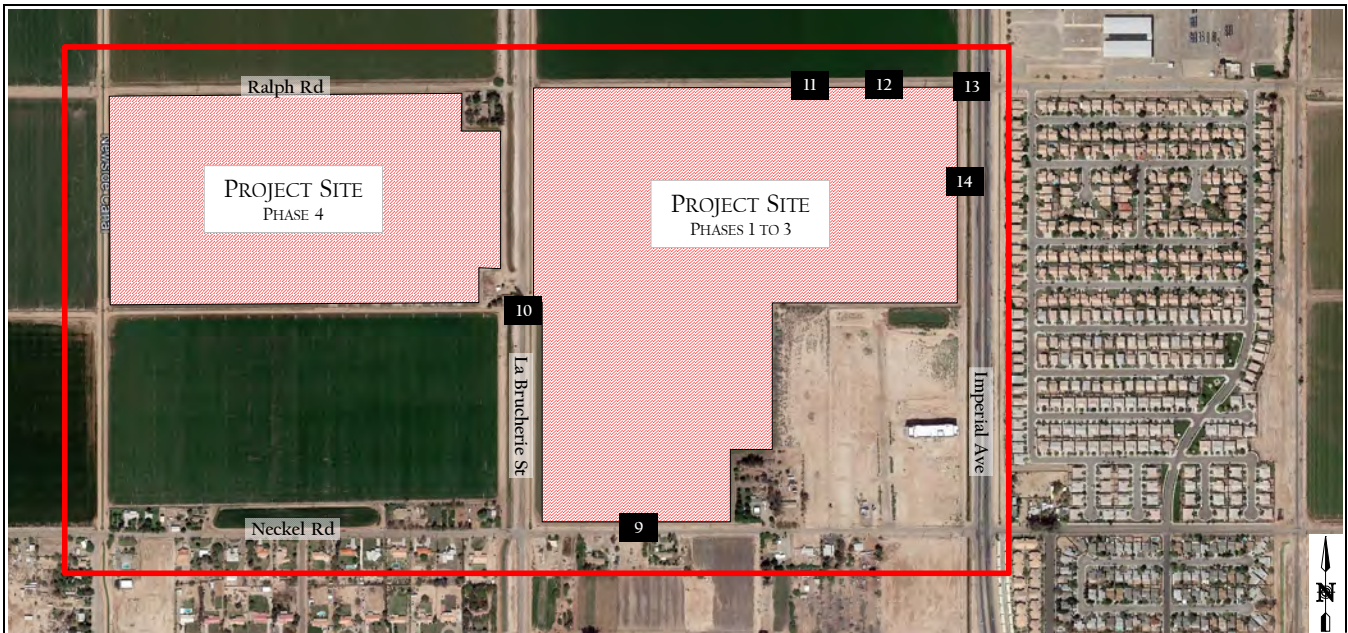

xx / yy - AM / PM Peak-Hour Turning Movement Volumes
 The naming convention for intersections is North / South & East / West

Proj Dwy & Neckel Rd	La Brucherie Rd & Proj Dwy	SFR Proj Dwy & Ralph Rd	MFR Proj Dwy & Ralph Rd
<p>9</p>	Does not exist	Does not exist	Does not exist
Retail Proj Dwy & Ralph Rd	Imperial Ave & Proj Dwy		
Does not exist	Does not exist		



Heritage at Dahlia Ranch
 Opening Year 2023 Plus Phase 1 Project Traffic Volumes

Figure 6-3a

Table 6-1
Opening Year 2023 Peak Hour Intersection LOS Summary

#	Intersection	Traffic Control	Peak Hour	Opening Year 2023		Opening Year 2023 w/Phase I Proj		Δ in Delay	Improvement?
				Delay ¹	LOS ²	Delay ¹	LOS ²		
1	SR-86 & Keystone Rd	Signal	AM	9.4	A	9.3	A	-0.1	No
			PM	9.3	A	9.3	A	0.0	No
2	SR-86 & Larson Rd	TWSC	AM	15.1	C	15.2	C	0.1	No
			PM	17.1	C	17.4	C	0.3	No
3	Imperial Ave & Ralph Rd	TWSC	AM	19.4	C	19.9	C	0.5	No
			PM	18.6	C	19.1	C	0.5	No
4	Imperial Ave & Neckel Rd	Signal	AM	18.2	B	21.1	C	2.9	No
			PM	14.7	B	17.2	B	2.5	No
5	La Brucherie Rd & Neckel Rd	TWSC	AM	10.2	B	10.3	B	0.1	No
			PM	9.7	A	9.7	A	0.0	No
6	Imperial Ave & Worthington Rd/Barioni Blvd	Signal	AM	28.0	C	29.5	C	1.5	No
			PM	21.6	C	22.4	C	0.8	No
7	La Brucherie Rd & Worthington Rd	AWSC	AM	19.3	C	19.8	C	0.5	No
			PM	10.5	B	10.7	B	0.2	No
8	Imperial Ave & Aten Rd	Signal	AM	30.7	C	31.6	C	0.9	No
			PM	24.8	C	26.0	C	1.2	No
9	Proj Dwy & Neckel Rd	OWSC	AM	DNE		10.2	B	10.2	No
			PM			9.7	A	9.7	No
10	La Brucherie Rd & Proj Dwy	OWSC	AM	DNE					
			PM						
11	SFR Proj Dwy & Ralph Rd	OWSC	AM	DNE					
			PM						
12	MFR Proj Dwy & Ralph Rd	OWSC	AM	DNE					
			PM						
13	Retail Proj Dwy & Ralph Rd	OWSC	AM	DNE					
			PM						
14	Imperial Ave & Proj Dwy	OWSC	AM	DNE					
			PM						

Notes:

OWSC: One-Way Stopped Control, TWSC: Two-Way Stopped Control, AWSC: All-Way Stopped Control

1. Delays are reported as the average control delay for the entire intersection at signalized intersections and the worst movement at unsignalized intersections.

2. LOS calculations are based on the methodology outlined in the *Highway Capacity Manual 6th Edition (HCM6)* and performed using Synchro II.

As shown in the table, all intersections, including the project driveway, are expected to operate at LOS C or better during the weekday peak-hours with the addition of the Project traffic. As a result, no additional intersection improvements are required and/or recommended.

6.4 Roadway Segment Analysis

Table 6-2 displays the LOS analysis for the study area roadway segments under the Opening Year 2023 with and without the Phase I Project traffic.

Table 6-2
Opening Year 2023 Roadway LOS Summary

Roadway Segment	Opening Year 2023			Opening Year 2023 w/Phase I Proj			Δ in V/C	Improvement?
	ADT	v/c Ratio	LOS	ADT	v/c Ratio	LOS		
SR-86								
North of Keystone Rd	15,298	0.41	B	15,549	0.42	B	0.007	No
Keystone Rd to Larsen Rd	14,603	0.40	A	14,854	0.40	B	0.006	No
Larsen Rd to Ralph Rd	14,031	0.38	A	14,282	0.39	A	0.007	No
Imperial Ave								
Ralph Rd to Neckel Rd	14,450	0.39	A	14,701	0.40	A	0.006	No
Neckel Rd to Worthington Rd	18,653	0.50	B	19,532	0.53	B	0.024	No
Worthington Rd to Aten Rd	20,546	0.56	B	21,300	0.58	B	0.021	No
South of Aten Rd	21,942	0.59	B	22,444	0.61	B	0.014	No

As shown in the table, all roadway segments would continue to function at LOS B or better with the addition of the Phase I Project traffic. As a result, no additional improvements are required and/or recommended.

7 OPENING YEAR 2024

This section summarizes the operations at the study area intersections, roadway segments, and project driveways with the addition of the Phase 2 project traffic in the anticipated year of opening in 2024.

7.1 Roadway Network

No changes to the existing roadway network are proposed under this condition except at the project driveway along La Brucherie Road. The Project will construct a southbound left-turn lane along La Brucherie Road. **Figure 7-1** illustrates the intersection geometrics with the addition of the Phase 2 Project traffic.

7.2 Traffic Volumes

The Opening Year 2024 Baseline Conditions traffic volumes were developed by applying the annual 1.4 percent regional growth factor and including the cumulative traffic volumes. This growth rate was applied to the existing traffic volumes for three years to estimate the Year 2024 baseline conditions.

Figure 7-2 illustrates the Opening Year 2024 Baseline traffic volumes. **Figure 7-3** illustrates the Opening Year 2024 Plus Phases 1 & 2 Project traffic volumes.

7.3 Intersection Analysis

Table 7-1 displays the LOS analysis results for the study intersections and project driveways under Opening Year 2024 Baseline and Plus Phases 1 & 2 Project conditions.

Appendix C contains the intersection LOS worksheets.

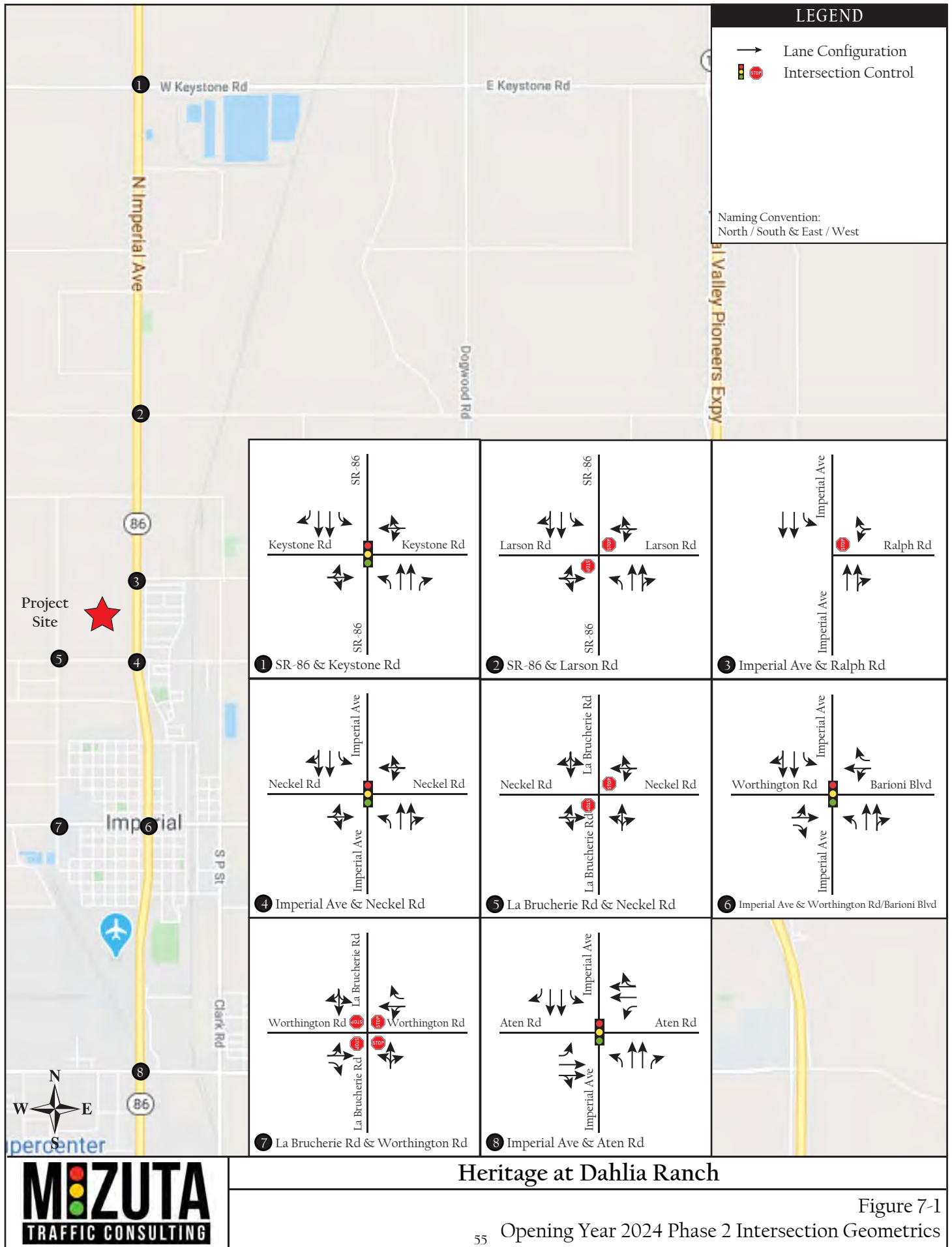

LEGEND

- Lane Configuration
- ⊠ Intersection Control

Naming Convention:
North / South & East / West

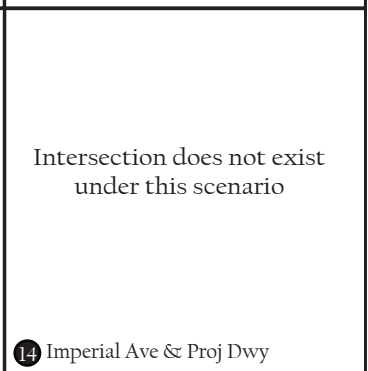
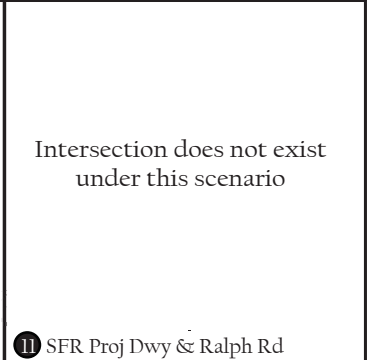
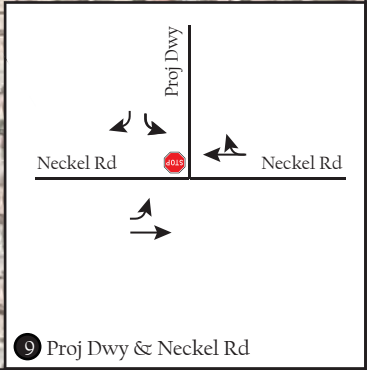
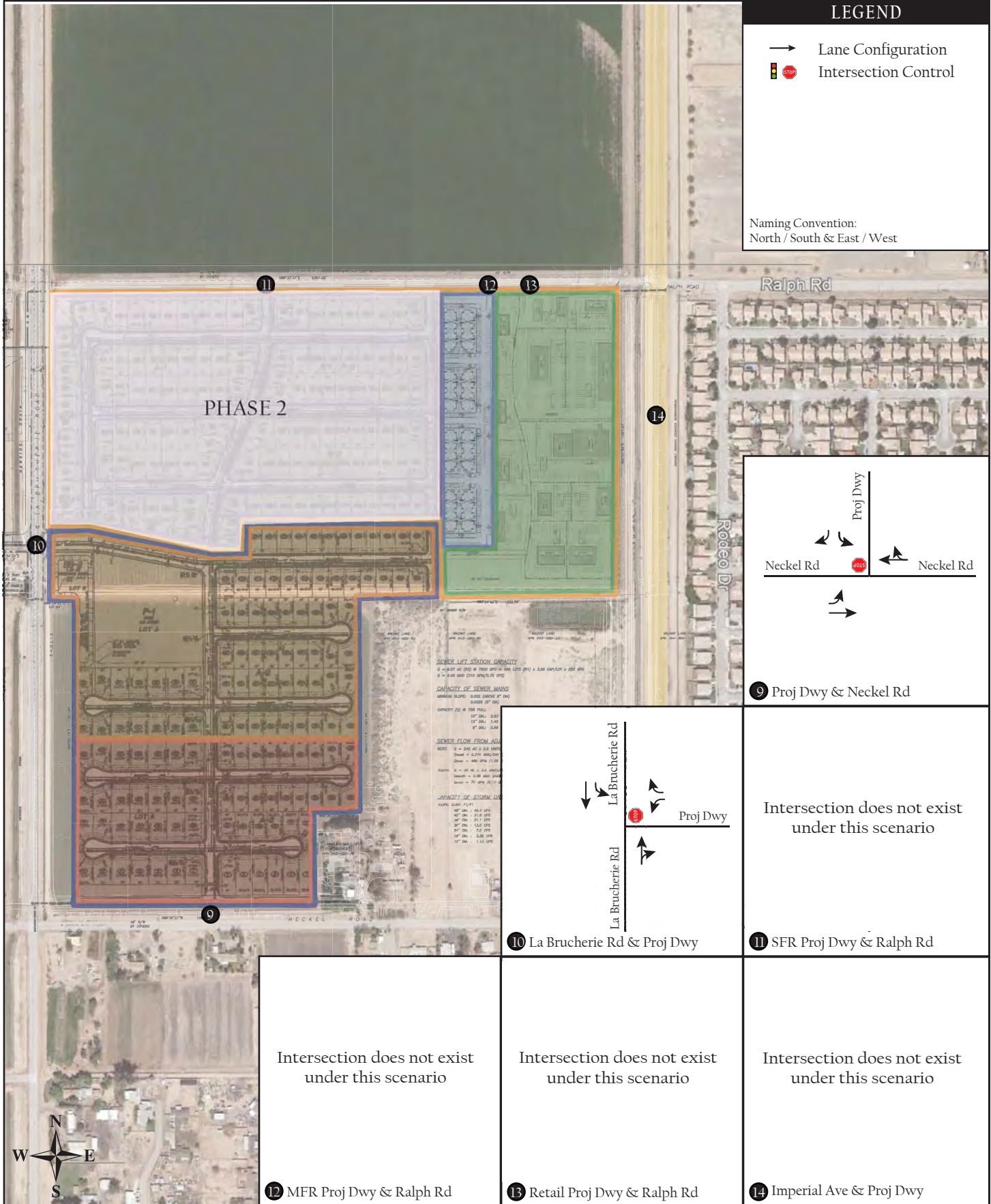

Intersection does not exist under this scenario

Intersection does not exist under this scenario

Intersection does not exist under this scenario



Heritage at Dahlia Ranch

Figure 7-1a

Opening Year 2024 Phase 2 Intersection Geometrics

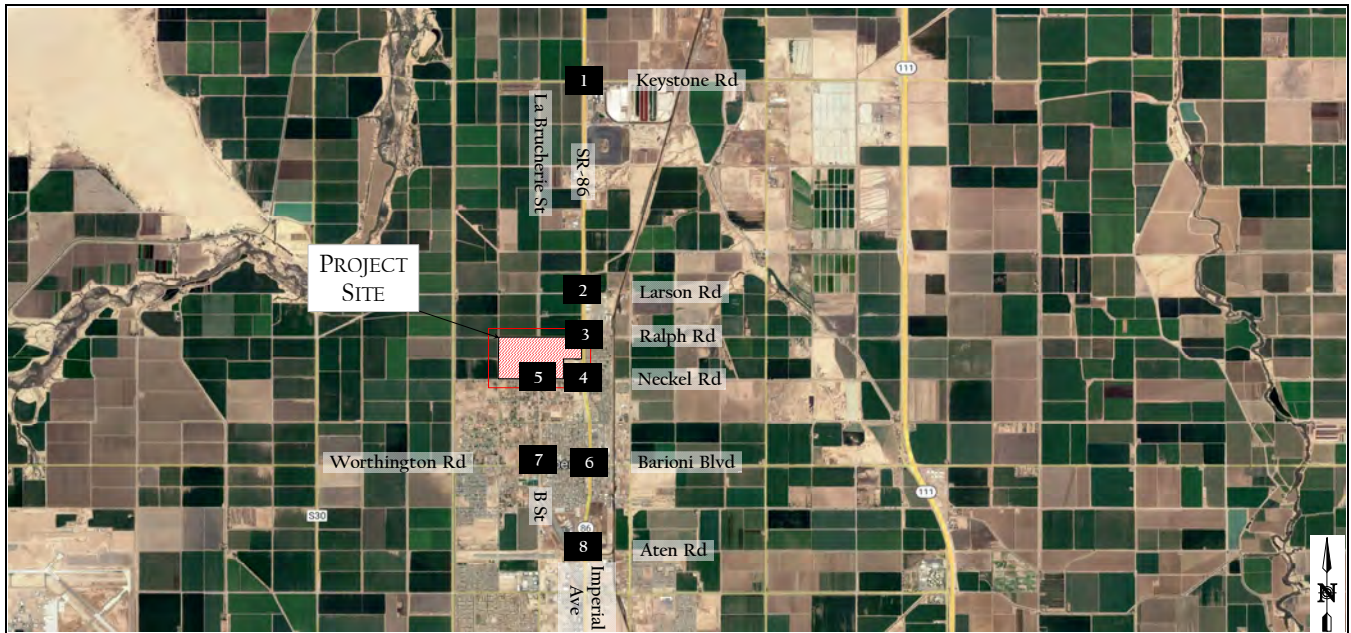

xx / yy - AM / PM Peak-Hour Turning Movement Volumes
 The naming convention for intersections is North / South & East / West

SR-86 & Keystone Rd		SR-86 & Larsen Rd		Imperial Ave & Ralph Rd		Imperial Ave & Neckel Rd	
38 / 34 519 / 549 46 / 53 ↙ ↘ ↕ ↗ ↖ 1	↙ ↘ ↕ ↗ ↖ 43 / 38 24 / 27 19 / 33	7 / 18 524 / 586 1 / 6 ↙ ↘ ↕ ↗ ↖ 2	↙ ↘ ↕ ↗ ↖ 5 / 5 2 / 0 1 / 7	507 / 549 20 / 30 ↙ ↘ ↕ ↗ ↖ 3	↙ ↘ ↕ ↗ ↖ 23 / 10 59 / 20	31 / 28 518 / 503 15 / 29 ↙ ↘ ↕ ↗ ↖ 4	↙ ↘ ↕ ↗ ↖ 56 / 47 65 / 20 144 / 83
33 / 42 33 / 13 11 / 20 ↙ ↘ ↕ ↗ ↖ 5	↙ ↘ ↕ ↗ ↖ 19 / 10 445 / 531 50 / 26	20 / 6 3 / 4 2 / 0 ↙ ↘ ↕ ↗ ↖ 6	↙ ↘ ↕ ↗ ↖ 0 / 1 513 / 569 1 / 7	491 / 570 42 / 30 ↙ ↘ ↕ ↗ ↖ 7	↙ ↘ ↕ ↗ ↖ 42 / 30	34 / 13 44 / 26 13 / 4 ↙ ↘ ↕ ↗ ↖ 8	↙ ↘ ↕ ↗ ↖ 8 / 11 448 / 563 66 / 84
La Brucherie Rd & Neckel Rd		Imperial Ave & Barioni Blvd / Worthington Rd		B St / La Brucherie Rd & Worthington Rd		Imperial Ave & Aten Rd	
1 / 7 2 / 5 1 / 0 ↙ ↘ ↕ ↗ ↖ 5	↙ ↘ ↕ ↗ ↖ 0 / 1 45 / 45 60 / 23	56 / 64 639 / 602 40 / 27 ↙ ↘ ↕ ↗ ↖ 6	↙ ↘ ↕ ↗ ↖ 78 / 52 133 / 114 55 / 55	65 / 24 31 / 5 107 / 38 ↙ ↘ ↕ ↗ ↖ 7	↙ ↘ ↕ ↗ ↖ 78 / 34 305 / 218 11 / 27	381 / 212 680 / 545 144 / 114 ↙ ↘ ↕ ↗ ↖ 8	↙ ↘ ↕ ↗ ↖ 143 / 124 303 / 292 132 / 180
4 / 2 42 / 39 23 / 8 ↙ ↘ ↕ ↗ ↖ 5	↙ ↘ ↕ ↗ ↖ 7 / 5 6 / 6 43 / 10	71 / 49 138 / 75 215 / 106 ↙ ↘ ↕ ↗ ↖ 6	↙ ↘ ↕ ↗ ↖ 94 / 114 471 / 676 51 / 15	62 / 26 395 / 190 121 / 33 ↙ ↘ ↕ ↗ ↖ 7	↙ ↘ ↕ ↗ ↖ 0 / 1 1 / 0	189 / 192 342 / 279 64 / 69 ↙ ↘ ↕ ↗ ↖ 8	↙ ↘ ↕ ↗ ↖ 62 / 79 348 / 674 68 / 151

	Heritage at Dahlia Ranch Opening Year 2024 Baseline Traffic Volumes	Figure 7-2
--	--	------------

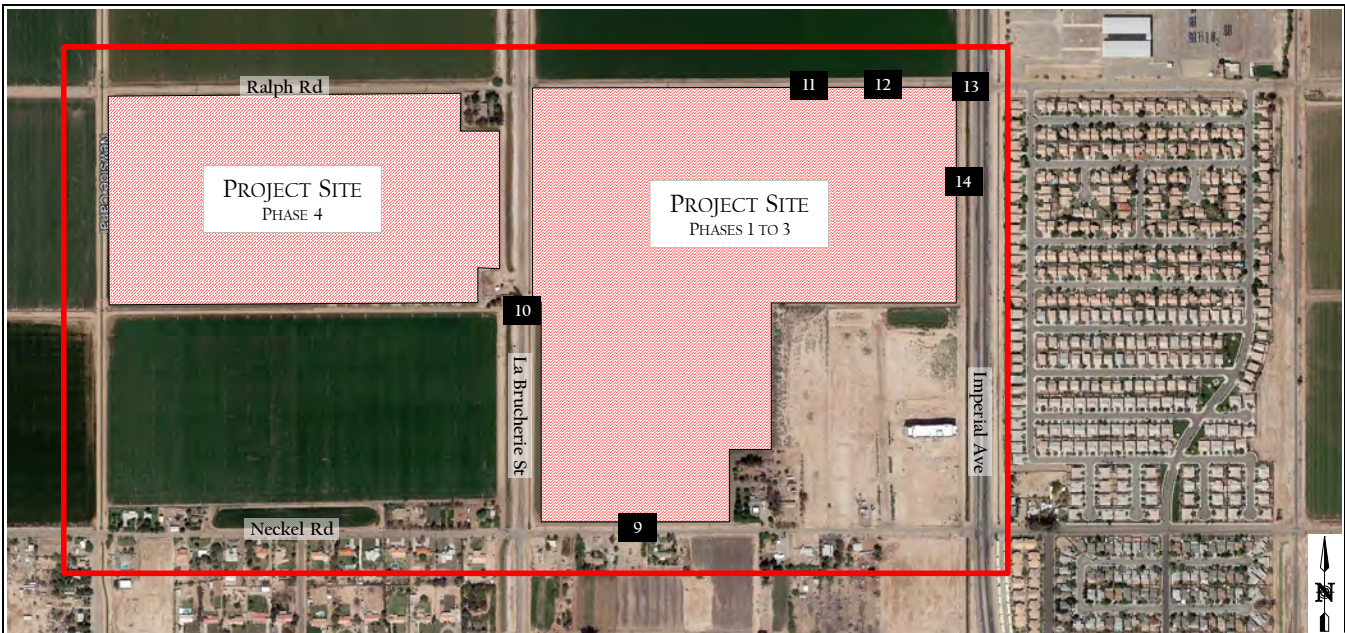

xx / yy - AM / PM Peak-Hour Turning Movement Volumes
 The naming convention for intersections is North / South & East / West

Proj Dwy & Neckel Rd	La Brucherie Rd & Proj Dwy	SFR Proj Dwy & Ralph Rd	MFR Proj Dwy & Ralph Rd
Does not exist	Does not exist	Does not exist	Does not exist
Retail Proj Dwy & Ralph Rd	Imperial Ave & Proj Dwy		
Does not exist	Does not exist		



Heritage at Dahlia Ranch
 Opening Year 2024 Baseline Traffic Volumes

Figure 7-2a

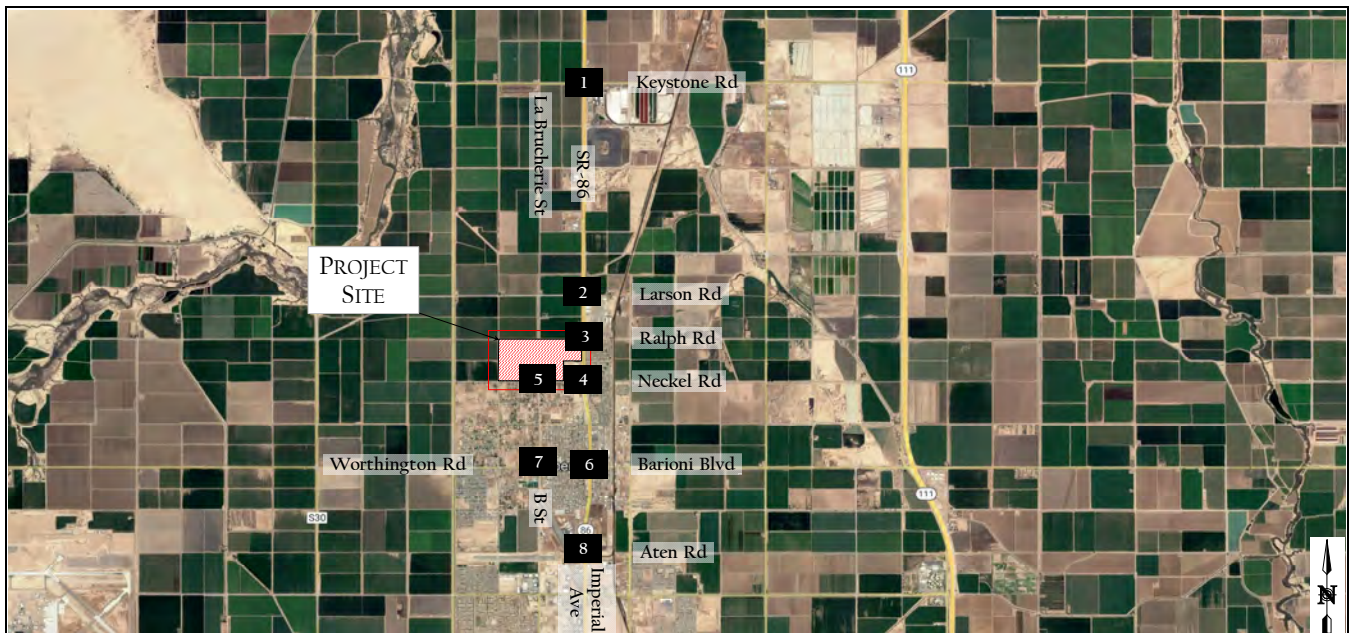

xx / yy - AM / PM Peak-Hour Turning Movement Volumes
 The naming convention for intersections is North / South & East / West

SR-86 & Keystone Rd		SR-86 & Larsen Rd		Imperial Ave & Ralph Rd		Imperial Ave & Neckel Rd									
38 / 34 ↘ ↙ 529 / 383 ↘ ↙ 46 / 53 ↘ ↙ 1	↘ ↙ 43 / 38 ↘ ↙ 24 / 27 ↘ ↙ 19 / 33	7 / 18 ↘ ↙ 534 / 620 ↘ ↙ 1 / 6 ↘ ↙ 2	↘ ↙ 5 / 5 ↘ ↙ 2 / 0 ↘ ↙ 1 / 7	517 / 583 ↘ ↙ 20 / 30 ↘ ↙ 23 / 10 ↘ ↙ 59 / 20 3	41 / 62 ↘ ↙ 518 / 503 ↘ ↙ 15 / 29 ↘ ↙ 56 / 47 ↘ ↙ 65 / 20 ↘ ↙ 144 / 83 4	33 / 42 ↘ ↙ 33 / 13 ↘ ↙ 11 / 20 ↘ ↙ 5	↘ ↙ 19 / 10 ↘ ↙ 475 / 551 ↘ ↙ 50 / 26	20 / 6 ↘ ↙ 3 / 4 ↘ ↙ 2 / 0 ↘ ↙ 6	0 / 1 ↘ ↙ 543 / 589 ↘ ↙ 1 / 7	521 / 590 ↘ ↙ 42 / 30 ↘ ↙ 7	64 / 33 ↘ ↙ 44 / 26 ↘ ↙ 117 / 72 ↘ ↙ 8	↘ ↙ 44 / 129 ↘ ↙ 448 / 563 ↘ ↙ 66 / 84			
La Brucherie Rd & Neckel Rd		Imperial Ave & Barioni Blvd / Worthington Rd		B St / La Brucherie Rd & Worthington Rd		Imperial Ave & Aten Rd									
1 / 7 ↘ ↙ 9 / 10 ↘ ↙ 23 / 14 ↘ ↙ 5	↘ ↙ 8 / 26 ↘ ↙ 45 / 45 ↘ ↙ 67 / 28	56 / 64 ↘ ↙ 727 / 660 ↘ ↙ 54 / 37 ↘ ↙ 6	↘ ↙ 84 / 68 ↘ ↙ 133 / 114 ↘ ↙ 55 / 55	79 / 34 ↘ ↙ 31 / 5 ↘ ↙ 107 / 38 ↘ ↙ 7	↘ ↙ 78 / 34 ↘ ↙ 305 / 218 ↘ ↙ 11 / 27	395 / 222 ↘ ↙ 740 / 583 ↘ ↙ 158 / 124 ↘ ↙ 8	↘ ↙ 149 / 140 ↘ ↙ 303 / 292 ↘ ↙ 132 / 180	4 / 2 ↘ ↙ 42 / 39 ↘ ↙ 23 / 8 ↘ ↙ 5	7 / 5 ↘ ↙ 9 / 14 ↘ ↙ 46 / 18	71 / 49 ↘ ↙ 138 / 75 ↘ ↙ 215 / 106 ↘ ↙ 6	94 / 114 ↘ ↙ 501 / 776 ↘ ↙ 51 / 15	68 / 42 ↘ ↙ 395 / 190 ↘ ↙ 121 / 33 ↘ ↙ 7	0 / 1 ↘ ↙ 1 / 0	195 / 208 ↘ ↙ 342 / 279 ↘ ↙ 64 / 69 ↘ ↙ 8	62 / 79 ↘ ↙ 368 / 742 ↘ ↙ 68 / 151

	<p>Heritage at Dahlia Ranch</p> <p>Opening Year 2024 Plus Phases 1 & 2 Project Traffic Volumes</p>	<p>Figure 7-3</p>
--	--	-------------------

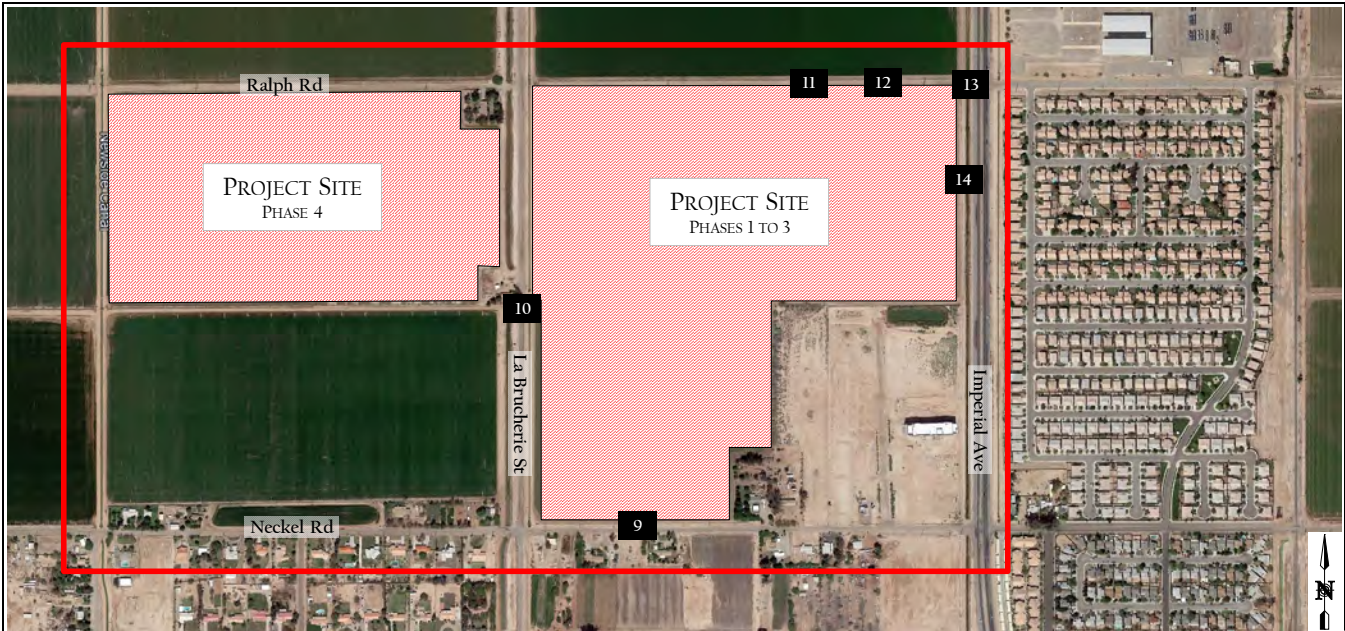

xx / yy - AM / PM Peak-Hour Turning Movement Volumes
 The naming convention for intersections is North / South & East / West

Proj Dwy & Neckel Rd		La Brucherie Rd & Proj Dwy		SFR Proj Dwy & Ralph Rd		MFR Proj Dwy & Ralph Rd	
				Does not exist		Does not exist	
Retail Proj Dwy & Ralph Rd		Imperial Ave & Proj Dwy		Does not exist			
Does not exist		Does not exist					



Heritage at Dahlia Ranch
 Opening Year 2024 Plus Phases 1 & 2 Project Traffic Volumes

Figure 7-3a

**Table 7-1
Opening Year 2024 Peak Hour Intersection LOS Summary**

#	Intersection	Traffic Control	Peak Hour	Opening Year 2024		Opening Year 2024 w/Phases 1&2 Proj		Δ in Delay	Improvement?
				Delay ¹	LOS ²	Delay ¹	LOS ²		
1	SR-86 & Keystone Rd	Signal	AM	9.4	A	9.3	A	-0.1	No
			PM	9.3	A	9.3	A	0.0	No
2	SR-86 & Larson Rd	TWSC	AM	15.2	C	15.5	C	0.3	No
			PM	17.3	C	17.9	C	0.6	No
3	Imperial Ave & Ralph Rd	TWSC	AM	19.7	C	20.8	C	1.1	No
			PM	18.9	C	19.8	C	0.9	No
4	Imperial Ave & Neckel Rd	Signal	AM	18.4	B	24.9	C	6.5	No
			PM	14.8	B	20.6	C	5.8	No
5	La Brucherie Rd & Neckel Rd	TWSC	AM	10.3	B	11.1	B	0.8	No
			PM	9.7	A	10.1	B	0.4	No
6	Imperial Ave & Worthington Rd/Barioni Blvd	Signal	AM	28.8	C	32.3	C	3.5	No
			PM	22.0	C	24.0	C	2.0	No
7	La Brucherie Rd & Worthington Rd	AWSC	AM	19.9	C	21.1	C	1.2	No
			PM	10.6	B	11.0	B	0.4	No
8	Imperial Ave & Aten Rd	Signal	AM	31.4	C	33.9	C	2.5	No
			PM	25.3	C	28.0	C	2.7	No
9	Proj Dwy & Neckel Rd	OWSC	AM	DNE		10.9	B	10.9	No
			PM			10.3	B	10.3	No
10	La Brucherie Rd & Proj Dwy	OWSC	AM	DNE		8.7	A	8.7	No
			PM			8.8	A	8.8	No
11	SFR Proj Dwy & Ralph Rd	OWSC	AM	DNE					
			PM						
12	MFR Proj Dwy & Ralph Rd	OWSC	AM	DNE					
			PM						
13	Retail Proj Dwy & Ralph Rd	OWSC	AM	DNE					
			PM						
14	Imperial Ave & Proj Dwy	OWSC	AM	DNE					

Notes:

OWSC: One-Way Stopped Control, TWSC: Two-Way Stopped Control, AWSC: All-Way Stopped Control

1. Delays are reported as the average control delay for the entire intersection at signalized intersections and the worst movement at unsignalized intersections.

2. LOS calculations are based on the methodology outlined in the *Highway Capacity Manual 6th Edition (HCM6)* and performed using Synchro II.

As shown in the table, all intersections, including the project driveway, are expected to operate at LOS C or better during the weekday peak-hours with the addition of the Project traffic. As a result, no additional intersection improvements are required and/or recommended.

7.4 Roadway Segment Analysis

Table 7-2 displays the LOS analysis for the study area roadway segments under the Opening Year 2024 with and without the Phase 2 Project traffic.

Table 7-2
Opening Year 2024 Roadway LOS Summary

Roadway Segment	Opening Year 2024			Opening Year 2024 w/Phases 1 & 2 Proj			Δ in V/C	Improvement?
	ADT	v/c Ratio	LOS	ADT	v/c Ratio	LOS		
SR-86								
North of Keystone Rd	15,506	0.42	B	16,008	0.43	B	0.014	No
Keystone Rd to Larsen Rd	14,802	0.40	B	15,304	0.41	B	0.014	No
Larsen Rd to Ralph Rd	14,222	0.38	A	14,724	0.40	A	0.014	No
Imperial Ave								
Ralph Rd to Neckel Rd	14,646	0.40	A	15,148	0.41	B	0.013	No
Neckel Rd to Worthington Rd	18,907	0.51	B	20,665	0.56	B	0.048	No
Worthington Rd to Aten Rd	20,825	0.56	B	22,333	0.60	B	0.041	No
South of Aten Rd	22,240	0.60	B	23,244	0.63	B	0.027	No

As shown in the table, all roadway segments would continue to function at LOS B or better with the addition of the Phases 1 and 2 Project traffic. As a result, no additional improvements are required and/or recommended.

8 OPENING YEAR 2026

This section summarizes the operations at the study area intersections, roadway segments, and project driveways with the addition of the Phase 3 project traffic in the anticipated year of opening in 2026.

8.1 Roadway Network

Under this scenario, Ralph Road is assumed to be constructed and extended to the west from Imperial Avenue until La Brucherie Road. The Imperial Avenue & Ralph Road intersection will be upgraded to include a traffic signal. The Project will construct a westbound left-turn lane along Ralph Road for entering traffic to access the multi-family and commercial/retail uses. Additionally, a southbound right-turn deceleration lane will be constructed at the new driveway along Imperial Avenue. **Figure 8-1** illustrates the intersection geometrics with the addition of the Phase 3 Project traffic.

8.2 Traffic Volumes

The Opening Year 2026 Baseline Conditions traffic volumes were developed by applying the annual 1.4 percent regional growth factor and including the cumulative traffic volumes. This growth rate was applied to the existing traffic volumes for five years to estimate the Year 2026 baseline conditions.

Figure 8-2 illustrates the Opening Year 2026 Baseline traffic volumes. **Figure 8-3** illustrates the Opening Year 2026 Plus Phases 1 to 3 Project traffic volumes.

8.3 Intersection Analysis

Table 8-1 displays the LOS analysis results for the study intersections and project driveways under Opening Year 2026 Baseline and Plus Phases 1 to 3 Project conditions.

Appendix C contains the intersection LOS worksheets.

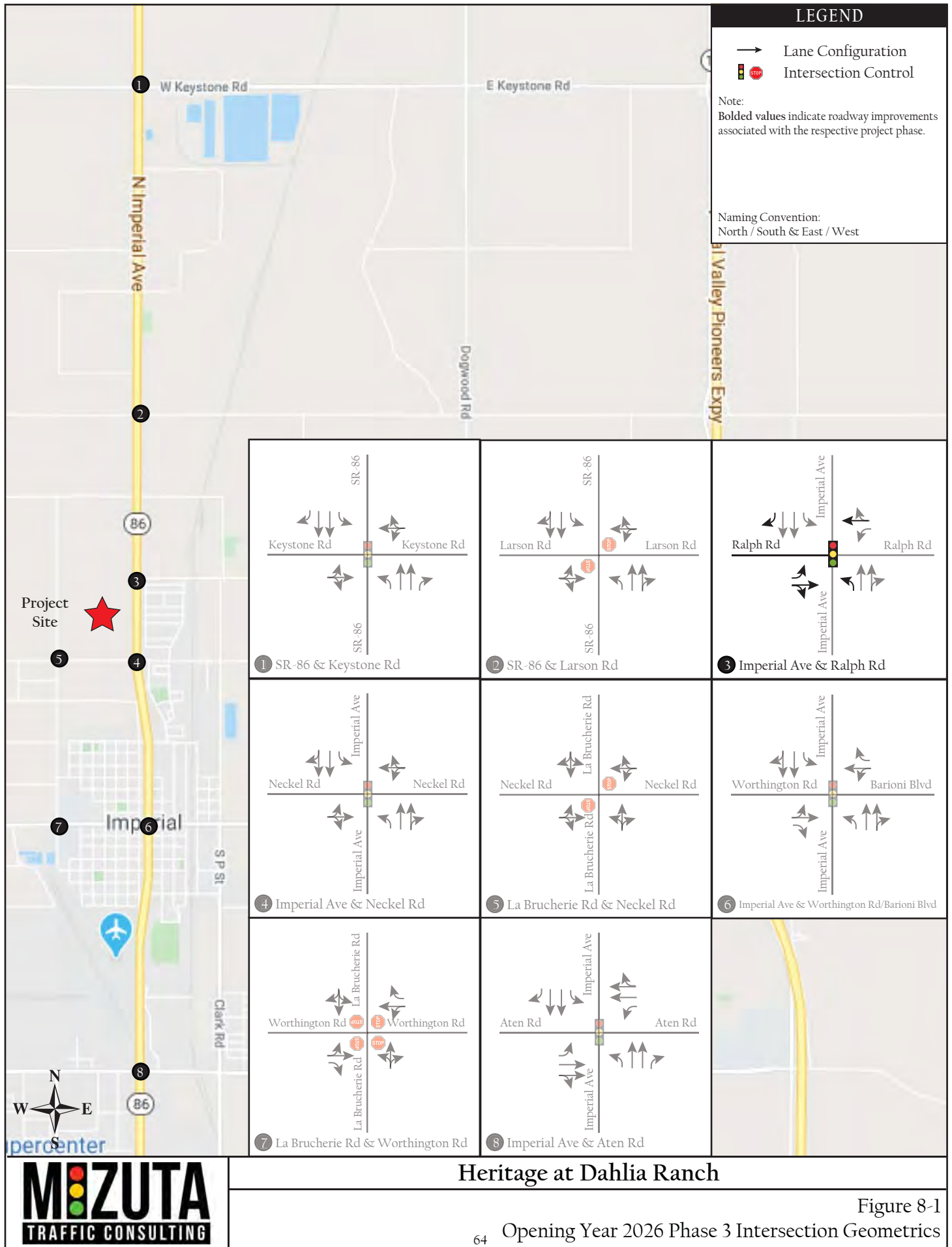

LEGEND

- Lane Configuration
- STOP Intersection Control

Naming Convention:
North / South & East / West

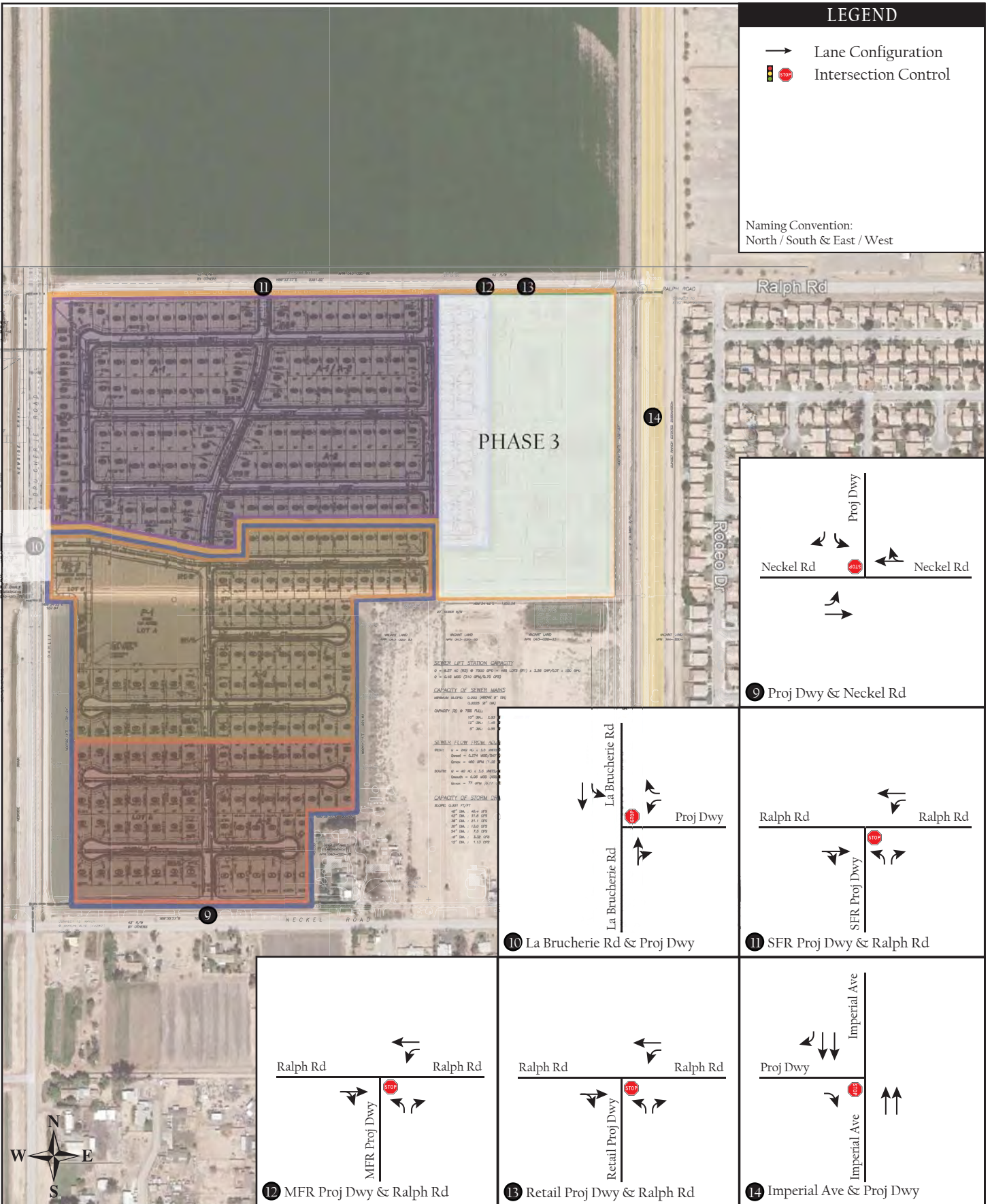

Heritage at Dahlia Ranch

Figure 8-1a

Opening Year 2026 Phase 3 Intersection Geometrics

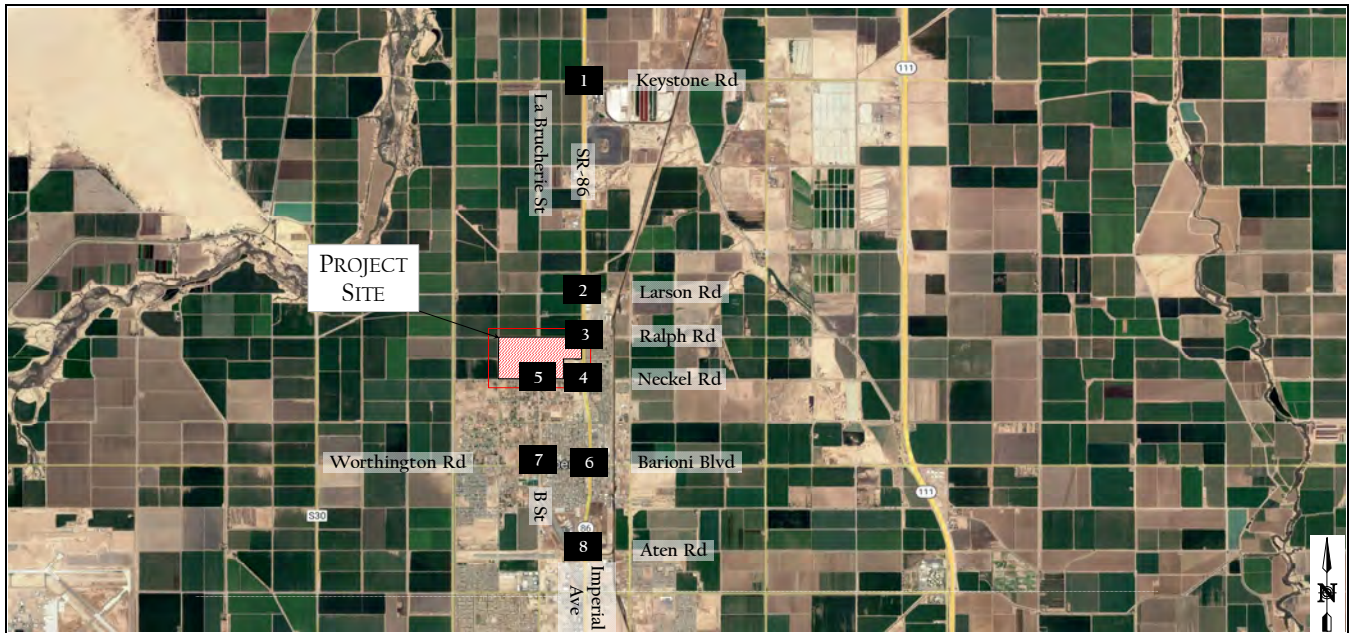

xx / yy - AM / PM Peak-Hour Turning Movement Volumes
 The naming convention for intersections is North / South & East / West

SR-86 & Keystone Rd		SR-86 & Larsen Rd		Imperial Ave & Ralph Rd		Imperial Ave & Neckel Rd																																	
39 / 35 ↘ ↙ 543 / 395 ↔ 47 / 55 ↗ ↖ 44 / 39 ↔ 25 / 28 ↗ ↖ 19 / 34	1	8 / 18 ↘ ↙ 548 / 632 ↔ 1 / 6 ↗ ↖ 5 / 5 ↔ 2 / 0 ↗ ↖ 1 / 8	2	330 / 395 ↘ ↙ 20 / 31 ↗ ↖ 24 / 11 ↔ 61 / 20	3	32 / 29 ↘ ↙ 533 / 517 ↔ 24 / 60 ↗ ↖ 85 / 66 ↔ 66 / 20 ↗ ↖ 228 / 139	4	34 / 43 ↘ ↙ 34 / 13 ↔ 12 / 20 ↗ ↖ 19 / 11 ↘ ↙ 485 / 564 ↔ 51 / 27	5	20 / 6 ↘ ↙ 3 / 4 ↔ 2 / 0 ↗ ↖ 0 / 1 ↘ ↙ 554 / 603 ↔ 1 / 8	6	532 / 604 ↘ ↙ 43 / 31 ↗ ↖	7	35 / 13 ↘ ↙ 45 / 27 ↔ 13 / 4 ↗ ↖ 9 / 12 ↘ ↙ 461 / 579 ↔ 95 / 178	8	La Brucherie Rd & Neckel Rd		Imperial Ave & Barioni Blvd / Worthington Rd		B St / La Brucherie Rd & Worthington Rd		Imperial Ave & Aten Rd		1 / 8 ↘ ↙ 2 / 5 ↔ 1 / 0 ↗ ↖ 0 / 1 ↔ 46 / 46 ↗ ↖ 62 / 24	5	71 / 74 ↘ ↙ 724 / 663 ↔ 41 / 28 ↗ ↖ 80 / 54 ↔ 137 / 117 ↗ ↖ 57 / 57	6	66 / 25 ↘ ↙ 32 / 5 ↔ 110 / 39 ↗ ↖ 80 / 35 ↔ 327 / 233 ↗ ↖ 12 / 28	7	404 / 227 ↘ ↙ 753 / 596 ↔ 148 / 117 ↗ ↖ 147 / 128 ↔ 312 / 300 ↗ ↖ 136 / 185	8	4 / 2 ↘ ↙ 43 / 40 ↔ 24 / 9 ↗ ↖ 8 / 5 ↘ ↙ 6 / 6 ↔ 44 / 11	5	78 / 65 ↘ ↙ 142 / 77 ↔ 221 / 109 ↗ ↖ 96 / 117 ↘ ↙ 508 / 771 ↔ 53 / 15	6	63 / 27 ↘ ↙ 411 / 210 ↔ 124 / 34 ↗ ↖ 0 / 1 ↘ ↙ 1 / 0	7	199 / 212 ↘ ↙ 352 / 287 ↔ 65 / 71 ↗ ↖ 63 / 81 ↘ ↙ 376 / 753 ↔ 70 / 155	8
34 / 43 ↘ ↙ 34 / 13 ↔ 12 / 20 ↗ ↖ 19 / 11 ↘ ↙ 485 / 564 ↔ 51 / 27	5	20 / 6 ↘ ↙ 3 / 4 ↔ 2 / 0 ↗ ↖ 0 / 1 ↘ ↙ 554 / 603 ↔ 1 / 8	6	532 / 604 ↘ ↙ 43 / 31 ↗ ↖	7	35 / 13 ↘ ↙ 45 / 27 ↔ 13 / 4 ↗ ↖ 9 / 12 ↘ ↙ 461 / 579 ↔ 95 / 178	8																																
La Brucherie Rd & Neckel Rd		Imperial Ave & Barioni Blvd / Worthington Rd		B St / La Brucherie Rd & Worthington Rd		Imperial Ave & Aten Rd																																	
1 / 8 ↘ ↙ 2 / 5 ↔ 1 / 0 ↗ ↖ 0 / 1 ↔ 46 / 46 ↗ ↖ 62 / 24	5	71 / 74 ↘ ↙ 724 / 663 ↔ 41 / 28 ↗ ↖ 80 / 54 ↔ 137 / 117 ↗ ↖ 57 / 57	6	66 / 25 ↘ ↙ 32 / 5 ↔ 110 / 39 ↗ ↖ 80 / 35 ↔ 327 / 233 ↗ ↖ 12 / 28	7	404 / 227 ↘ ↙ 753 / 596 ↔ 148 / 117 ↗ ↖ 147 / 128 ↔ 312 / 300 ↗ ↖ 136 / 185	8	4 / 2 ↘ ↙ 43 / 40 ↔ 24 / 9 ↗ ↖ 8 / 5 ↘ ↙ 6 / 6 ↔ 44 / 11	5	78 / 65 ↘ ↙ 142 / 77 ↔ 221 / 109 ↗ ↖ 96 / 117 ↘ ↙ 508 / 771 ↔ 53 / 15	6	63 / 27 ↘ ↙ 411 / 210 ↔ 124 / 34 ↗ ↖ 0 / 1 ↘ ↙ 1 / 0	7	199 / 212 ↘ ↙ 352 / 287 ↔ 65 / 71 ↗ ↖ 63 / 81 ↘ ↙ 376 / 753 ↔ 70 / 155	8																								
4 / 2 ↘ ↙ 43 / 40 ↔ 24 / 9 ↗ ↖ 8 / 5 ↘ ↙ 6 / 6 ↔ 44 / 11	5	78 / 65 ↘ ↙ 142 / 77 ↔ 221 / 109 ↗ ↖ 96 / 117 ↘ ↙ 508 / 771 ↔ 53 / 15	6	63 / 27 ↘ ↙ 411 / 210 ↔ 124 / 34 ↗ ↖ 0 / 1 ↘ ↙ 1 / 0	7	199 / 212 ↘ ↙ 352 / 287 ↔ 65 / 71 ↗ ↖ 63 / 81 ↘ ↙ 376 / 753 ↔ 70 / 155	8																																

	<p>Heritage at Dahlia Ranch</p> <p>Opening Year 2026 Baseline Traffic Volumes</p>	<p>Figure 8-2</p>
--	---	-------------------

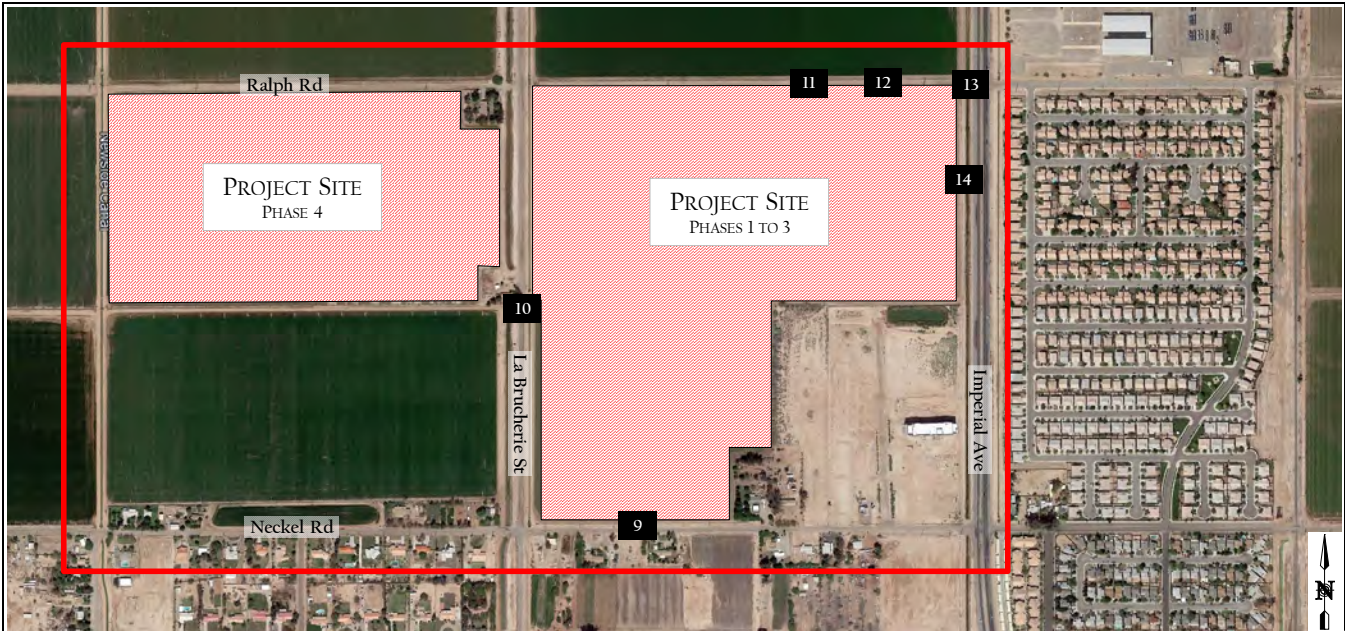

xx / yy - AM / PM Peak-Hour Turning Movement Volumes
 The naming convention for intersections is North / South & East / West

Proj Dwy & Neckel Rd	La Brucherie Rd & Proj Dwy	SFR Proj Dwy & Ralph Rd	MFR Proj Dwy & Ralph Rd
Does not exist	Does not exist	Does not exist	Does not exist
Retail Proj Dwy & Ralph Rd	Imperial Ave & Proj Dwy		
Does not exist	Does not exist		



Heritage at Dahlia Ranch
 Opening Year 2026 Baseline Traffic Volumes

Figure 8-2a

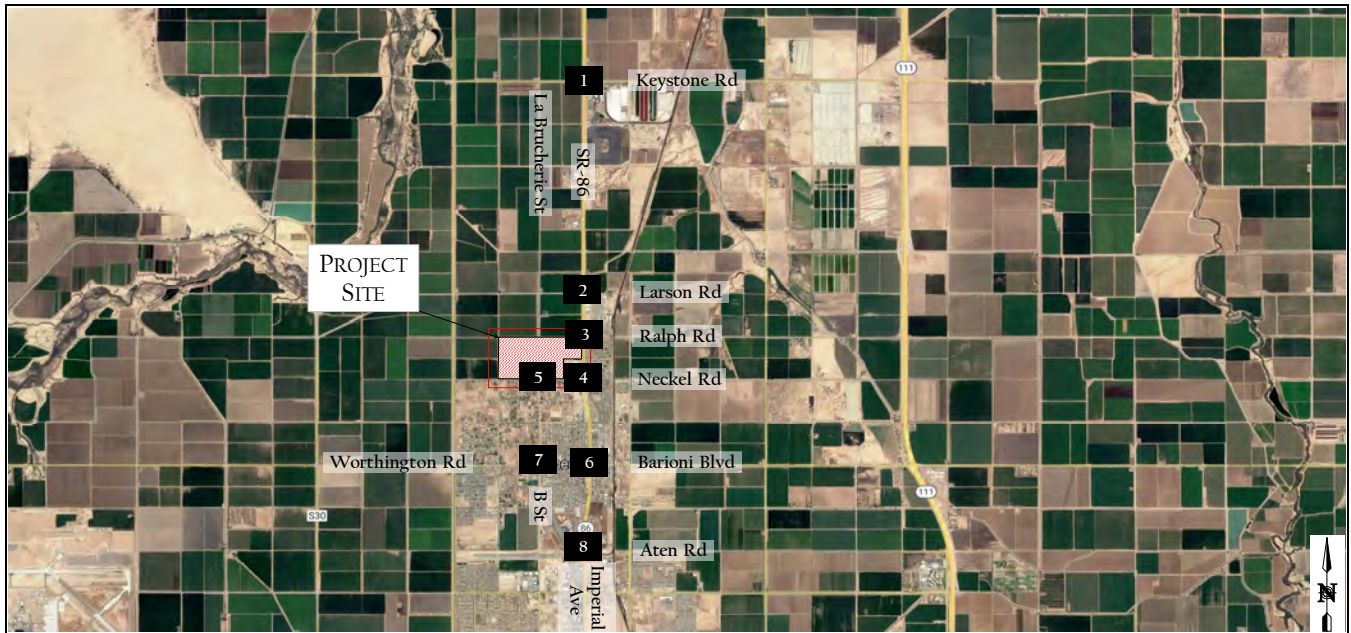

xx / yy - AM / PM Peak-Hour Turning Movement Volumes
 The naming convention for intersections is North / South & East / West

SR-86 & Keystone Rd		SR-86 & Larsen Rd		Imperial Ave & Ralph Rd		Imperial Ave & Neckel Rd																																	
39 / 35 ↘ ↙ 591 / 672 ↔ 47 / 55 ↗ ↖ 44 / 39 ↘ ↙ 25 / 28 ↔ 19 / 34 ↗ ↖	1	8 / 18 ↘ ↙ 596 / 709 ↔ 1 / 6 ↗ ↖ 5 / 5 ↘ ↙ 2 / 0 ↔ 1 / 8 ↗ ↖	2	31 / 59 ↘ ↙ 547 / 613 ↔ 20 / 31 ↗ ↖ 24 / 11 ↘ ↙ 17 / 18 ↔ 61 / 20 ↗ ↖	3	32 / 29 ↘ ↙ 671 / 672 ↔ 35 / 82 ↗ ↖ 102 / 84 ↘ ↙ 66 / 20 ↔ 228 / 139 ↗ ↖	4	34 / 43 ↘ ↙ 34 / 13 ↔ 12 / 20 ↗ ↖ 19 / 11 ↘ ↙ 545 / 630 ↔ 51 / 27 ↗ ↖ 51 / 27		20 / 6 ↘ ↙ 3 / 4 ↔ 2 / 0 ↗ ↖ 0 / 1 ↘ ↙ 614 / 669 ↔ 1 / 8 ↗ ↖ 1 / 8		60 / 66 ↘ ↙ 11 / 22 ↔ 106 / 90 ↗ ↖ 134 / 192 ↘ ↙ 532 / 604 ↔ 43 / 31 ↗ ↖ 43 / 31		35 / 13 ↘ ↙ 45 / 27 ↔ 65 / 38 ↗ ↖ 27 / 71 ↘ ↙ 578 / 754 ↔ 95 / 178 ↗ ↖ 95 / 178		La Brucherie Rd & Neckel Rd		Imperial Ave & Barioni Blvd / Worthington Rd		B St / La Brucherie Rd & Worthington Rd		Imperial Ave & Aten Rd		1 / 8 ↘ ↙ 25 / 34 ↔ 77 / 94 ↗ ↖ 67 / 105 ↘ ↙ 46 / 46 ↔ 69 / 29 ↗ ↖	5	71 / 74 ↘ ↙ 883 / 818 ↔ 72 / 62 ↗ ↖ 104 / 93 ↘ ↙ 137 / 117 ↔ 57 / 57 ↗ ↖	6	97 / 59 ↘ ↙ 32 / 5 ↔ 110 / 39 ↗ ↖ 80 / 35 ↘ ↙ 327 / 233 ↔ 12 / 28 ↗ ↖	7	435 / 261 ↘ ↙ 852 / 685 ↔ 179 / 151 ↗ ↖ 171 / 167 ↘ ↙ 312 / 300 ↔ 136 / 185 ↗ ↖	8	4 / 2 ↘ ↙ 43 / 40 ↔ 24 / 9 ↗ ↖ 8 / 5 ↘ ↙ 28 / 36 ↔ 47 / 19 ↗ ↖ 47 / 19		78 / 65 ↘ ↙ 142 / 77 ↔ 221 / 109 ↗ ↖ 96 / 117 ↘ ↙ 618 / 966 ↔ 53 / 15 ↗ ↖ 53 / 15		87 / 66 ↘ ↙ 411 / 210 ↔ 124 / 34 ↗ ↖ 0 / 1 ↘ ↙ 1 / 0 ↗ ↖ 1 / 0		223 / 251 ↘ ↙ 352 / 287 ↔ 65 / 71 ↗ ↖ 63 / 81 ↘ ↙ 437 / 871 ↔ 70 / 155 ↗ ↖ 70 / 155	
34 / 43 ↘ ↙ 34 / 13 ↔ 12 / 20 ↗ ↖ 19 / 11 ↘ ↙ 545 / 630 ↔ 51 / 27 ↗ ↖ 51 / 27		20 / 6 ↘ ↙ 3 / 4 ↔ 2 / 0 ↗ ↖ 0 / 1 ↘ ↙ 614 / 669 ↔ 1 / 8 ↗ ↖ 1 / 8		60 / 66 ↘ ↙ 11 / 22 ↔ 106 / 90 ↗ ↖ 134 / 192 ↘ ↙ 532 / 604 ↔ 43 / 31 ↗ ↖ 43 / 31		35 / 13 ↘ ↙ 45 / 27 ↔ 65 / 38 ↗ ↖ 27 / 71 ↘ ↙ 578 / 754 ↔ 95 / 178 ↗ ↖ 95 / 178		La Brucherie Rd & Neckel Rd		Imperial Ave & Barioni Blvd / Worthington Rd		B St / La Brucherie Rd & Worthington Rd		Imperial Ave & Aten Rd		1 / 8 ↘ ↙ 25 / 34 ↔ 77 / 94 ↗ ↖ 67 / 105 ↘ ↙ 46 / 46 ↔ 69 / 29 ↗ ↖	5	71 / 74 ↘ ↙ 883 / 818 ↔ 72 / 62 ↗ ↖ 104 / 93 ↘ ↙ 137 / 117 ↔ 57 / 57 ↗ ↖	6	97 / 59 ↘ ↙ 32 / 5 ↔ 110 / 39 ↗ ↖ 80 / 35 ↘ ↙ 327 / 233 ↔ 12 / 28 ↗ ↖	7	435 / 261 ↘ ↙ 852 / 685 ↔ 179 / 151 ↗ ↖ 171 / 167 ↘ ↙ 312 / 300 ↔ 136 / 185 ↗ ↖	8	4 / 2 ↘ ↙ 43 / 40 ↔ 24 / 9 ↗ ↖ 8 / 5 ↘ ↙ 28 / 36 ↔ 47 / 19 ↗ ↖ 47 / 19		78 / 65 ↘ ↙ 142 / 77 ↔ 221 / 109 ↗ ↖ 96 / 117 ↘ ↙ 618 / 966 ↔ 53 / 15 ↗ ↖ 53 / 15		87 / 66 ↘ ↙ 411 / 210 ↔ 124 / 34 ↗ ↖ 0 / 1 ↘ ↙ 1 / 0 ↗ ↖ 1 / 0		223 / 251 ↘ ↙ 352 / 287 ↔ 65 / 71 ↗ ↖ 63 / 81 ↘ ↙ 437 / 871 ↔ 70 / 155 ↗ ↖ 70 / 155									
La Brucherie Rd & Neckel Rd		Imperial Ave & Barioni Blvd / Worthington Rd		B St / La Brucherie Rd & Worthington Rd		Imperial Ave & Aten Rd																																	
1 / 8 ↘ ↙ 25 / 34 ↔ 77 / 94 ↗ ↖ 67 / 105 ↘ ↙ 46 / 46 ↔ 69 / 29 ↗ ↖	5	71 / 74 ↘ ↙ 883 / 818 ↔ 72 / 62 ↗ ↖ 104 / 93 ↘ ↙ 137 / 117 ↔ 57 / 57 ↗ ↖	6	97 / 59 ↘ ↙ 32 / 5 ↔ 110 / 39 ↗ ↖ 80 / 35 ↘ ↙ 327 / 233 ↔ 12 / 28 ↗ ↖	7	435 / 261 ↘ ↙ 852 / 685 ↔ 179 / 151 ↗ ↖ 171 / 167 ↘ ↙ 312 / 300 ↔ 136 / 185 ↗ ↖	8	4 / 2 ↘ ↙ 43 / 40 ↔ 24 / 9 ↗ ↖ 8 / 5 ↘ ↙ 28 / 36 ↔ 47 / 19 ↗ ↖ 47 / 19		78 / 65 ↘ ↙ 142 / 77 ↔ 221 / 109 ↗ ↖ 96 / 117 ↘ ↙ 618 / 966 ↔ 53 / 15 ↗ ↖ 53 / 15		87 / 66 ↘ ↙ 411 / 210 ↔ 124 / 34 ↗ ↖ 0 / 1 ↘ ↙ 1 / 0 ↗ ↖ 1 / 0		223 / 251 ↘ ↙ 352 / 287 ↔ 65 / 71 ↗ ↖ 63 / 81 ↘ ↙ 437 / 871 ↔ 70 / 155 ↗ ↖ 70 / 155																									
4 / 2 ↘ ↙ 43 / 40 ↔ 24 / 9 ↗ ↖ 8 / 5 ↘ ↙ 28 / 36 ↔ 47 / 19 ↗ ↖ 47 / 19		78 / 65 ↘ ↙ 142 / 77 ↔ 221 / 109 ↗ ↖ 96 / 117 ↘ ↙ 618 / 966 ↔ 53 / 15 ↗ ↖ 53 / 15		87 / 66 ↘ ↙ 411 / 210 ↔ 124 / 34 ↗ ↖ 0 / 1 ↘ ↙ 1 / 0 ↗ ↖ 1 / 0		223 / 251 ↘ ↙ 352 / 287 ↔ 65 / 71 ↗ ↖ 63 / 81 ↘ ↙ 437 / 871 ↔ 70 / 155 ↗ ↖ 70 / 155																																	

	<p>Heritage at Dahlia Ranch</p> <p>Opening Year 2026 Plus Phases 1 to 3 Project Traffic Volumes</p>	<p>Figure 8-3</p>
--	---	-------------------

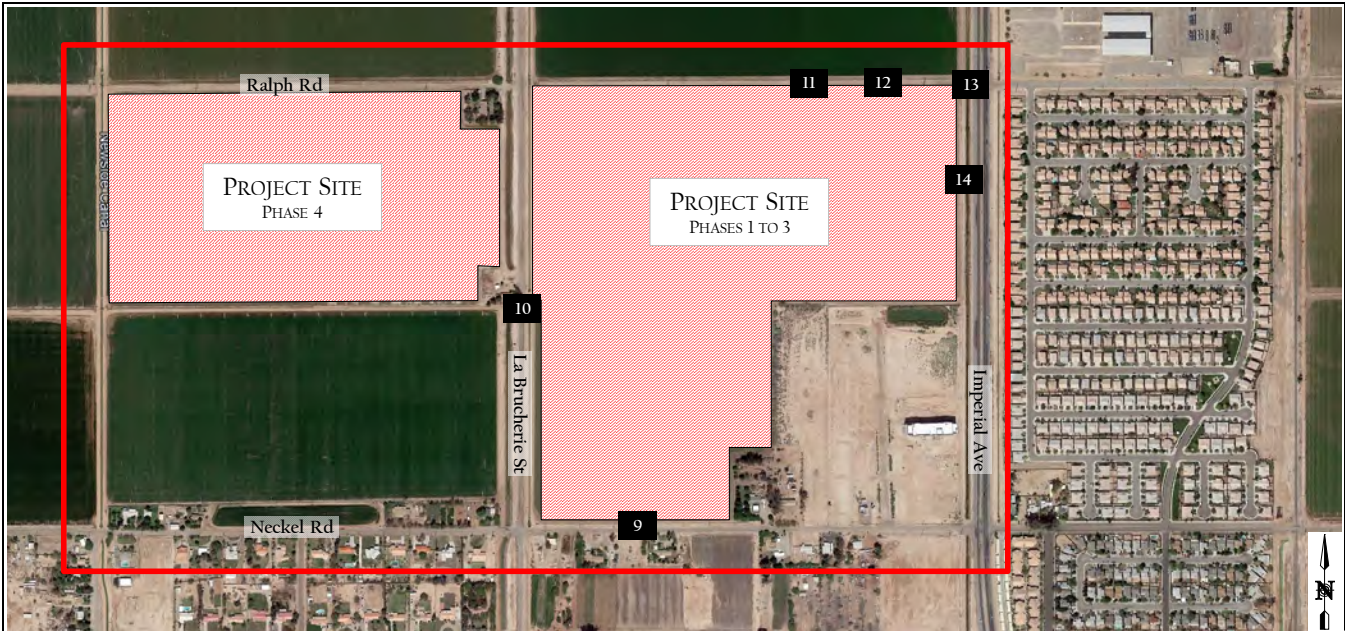

xx / yy - AM / PM Peak-Hour Turning Movement Volumes
 The naming convention for intersections is North / South & East / West

Proj Dwy & Neckel Rd	La Brucherie Rd & Proj Dwy	SFR Proj Dwy & Ralph Rd	MFR Proj Dwy & Ralph Rd
<p>7 / 5</p> <p>52 / 34</p> <p>18 / 59</p> <p>107 / 61</p> <p>9</p> <p>3 / 8</p> <p>93 / 44</p>	<p>32 / 51</p> <p>7 / 5</p> <p>10</p> <p>43 / 48</p> <p>3 / 8</p>	<p>28 / 38</p> <p>28 / 92</p> <p>11</p> <p>32 / 38</p> <p>81 / 53</p>	<p>51 / 128</p> <p>16 / 33</p> <p>12</p> <p>111 / 87</p> <p>2 / 4</p> <p>5 / 2</p> <p>42 / 17</p>
Retail Proj Dwy & Ralph Rd	Imperial Ave & Proj Dwy		
<p>44 / 125</p> <p>242 / 270</p> <p>13</p> <p>123 / 70</p> <p>30 / 34</p> <p>23 / 36</p> <p>116 / 180</p>	<p>30 / 34</p> <p>713 / 704</p> <p>14</p> <p>92 / 144</p> <p>760 / 904</p>		



Heritage at Dahlia Ranch
 Opening Year 2026 Plus Phases 1 to 3 Project Traffic Volumes

Figure 8-3a

**Table 8-1
Opening Year 2026 Peak Hour Intersection LOS Summary**

#	Intersection	Traffic Control	Peak Hour	Opening Year 2026		Opening Year 2026 w/Phases 1 to 3 Proj		Δ in Delay	Improvement?
				Delay ¹	LOS ²	Delay ¹	LOS ²		
1	SR-86 & Keystone Rd	Signal	AM	9.4	A	9.4	A	0.0	No
			PM	9.4	A	9.4	A	0.0	No
2	SR-86 & Larson Rd	TWSC	AM	15.8	C	16.8	C	1.0	No
			PM	18.2	C	20.0	C	1.8	No
3	Imperial Ave & Ralph Rd	Signal	AM	21.5	C	18.0	B	-3.5	No
			PM	20.1	C	22.4	C	2.3	No
4	Imperial Ave & Neckel Rd	Signal	AM	23.1	C	34.0	C	10.9	No
			PM	18.8	B	28.0	C	9.2	No
5	La Brucherie Rd & Neckel Rd	TWSC	AM	10.3	B	13.8	B	3.5	No
			PM	9.7	A	12.4	B	2.7	No
6	Imperial Ave & Worthington Rd/Barioni Blvd	Signal	AM	33.8	C	51.2	D	17.4	No
			PM	25.2	C	35.3	D	10.1	No
7	La Brucherie Rd & Worthington Rd	AWSC	AM	22.5	C	27.7	D	5.2	No
			PM	11.1	B	12.2	B	1.1	No
8	Imperial Ave & Aten Rd	Signal	AM	35.2	D	40.2	D	5.0	No
			PM	28.1	C	37.9	D	9.8	No
9	Proj Dwy & Neckel Rd	OWSC	AM	DNE		10.0	A	10.0	No
			PM	DNE		9.5	A	9.5	No
10	La Brucherie Rd & Proj Dwy	OWSC	AM	DNE		9.0	A	9.0	No
			PM	DNE		9.1	A	9.1	No
11	SFR Proj Dwy & Ralph Rd	OWSC	AM	DNE		8.8	A	8.8	No
			PM	DNE		8.7	A	8.7	No
12	MFR Proj Dwy & Ralph Rd	OWSC	AM	DNE		9.2	A	9.2	No
			PM	DNE		9.0	A	9.0	No
13	Retail Proj Dwy & Ralph Rd	OWSC	AM	DNE		10.9	B	10.9	No
			PM	DNE		11.4	B	11.4	No
14	Imperial Ave & Proj Dwy	OWSC	AM	DNE		12.0	B	12.0	No
			PM	DNE		12.8	B	12.8	No

Notes:

OWSC: One-Way Stopped Control, TWSC: Two-Way Stopped Control, AWSC: All-Way Stopped Control

1. Delays are reported as the average control delay for the entire intersection at signalized intersections and the worst movement at unsignalized intersections.

2. LOS calculations are based on the methodology outlined in the *Highway Capacity Manual 6th Edition (HCM6)* and performed using Synchro II.

As shown in the table, all intersections, including the project driveways, are expected to operate at LOS D or better during the weekday peak-hours with the addition of the Project traffic. As a result, no additional intersection improvements are required and/or recommended.

8.4 Roadway Segment Analysis

Table 8-2 displays the LOS analysis for the study area roadway segments under the Opening Year 2026 with and without the Phase 3 Project traffic.

Table 8-2
Opening Year 2026 Roadway LOS Summary

Roadway Segment	Opening Year 2026			Opening Year 2026 w/Phases 1 to 3 Proj			Δ in V/C	Improvement?
	ADT	v/c Ratio	LOS	ADT	v/c Ratio	LOS		
SR-86								
North of Keystone Rd	16,378	0.44	B	18,102	0.49	B	0.046	No
Keystone Rd to Larsen Rd	15,654	0.42	B	17,378	0.47	B	0.047	No
Larsen Rd to Ralph Rd	15,059	0.41	B	16,783	0.45	B	0.047	No
Imperial Ave								
Ralph Rd to Neckel Rd	15,495	0.42	B	20,300	0.55	B	0.130	No
Neckel Rd to Worthington Rd	20,781	0.56	B	25,173	0.68	C	0.118	No
Worthington Rd to Aten Rd	22,523	0.61	B	26,493	0.72	C	0.107	No
South of Aten Rd	23,748	0.64	B	25,992	0.70	C	0.060	No

As shown in the table, all roadway segments would continue to function at LOS C or better with the addition of the project traffic. As a result, no additional improvements are required and/or recommended.

9 OPENING YEAR 2028

This section summarizes the operations at the study area intersections, roadway segments, and project driveways with the addition of the Phase 4 project traffic in the anticipated year of opening in 2028.

9.1 Roadway Network

No changes to the existing roadway network are proposed under this condition except for the construction of the west leg of the La Brucherie Road & Project Driveway intersection. **Figure 9-1** illustrates the intersection geometrics with the addition of the Phase 4 Project traffic.

9.2 Traffic Volumes

The Opening Year 2028 Baseline Conditions traffic volumes were developed by applying the annual 1.4 percent regional growth factor and including the cumulative traffic volumes. This growth rate was applied to the existing traffic volumes for seven years to estimate the Year 2028 baseline conditions.

Figure 9-2 illustrates the Opening Year 2028 Baseline traffic volumes. **Figure 9-3** illustrates the Opening Year 2028 Plus Phases 1 to 4 Project traffic volumes.

9.3 Intersection Analysis

Table 9-1 displays the LOS analysis results for the study intersections and project driveways under Opening Year 2028 Baseline and Plus Phases 1 to 4 Project conditions.

Appendix C contains the intersection LOS worksheets.

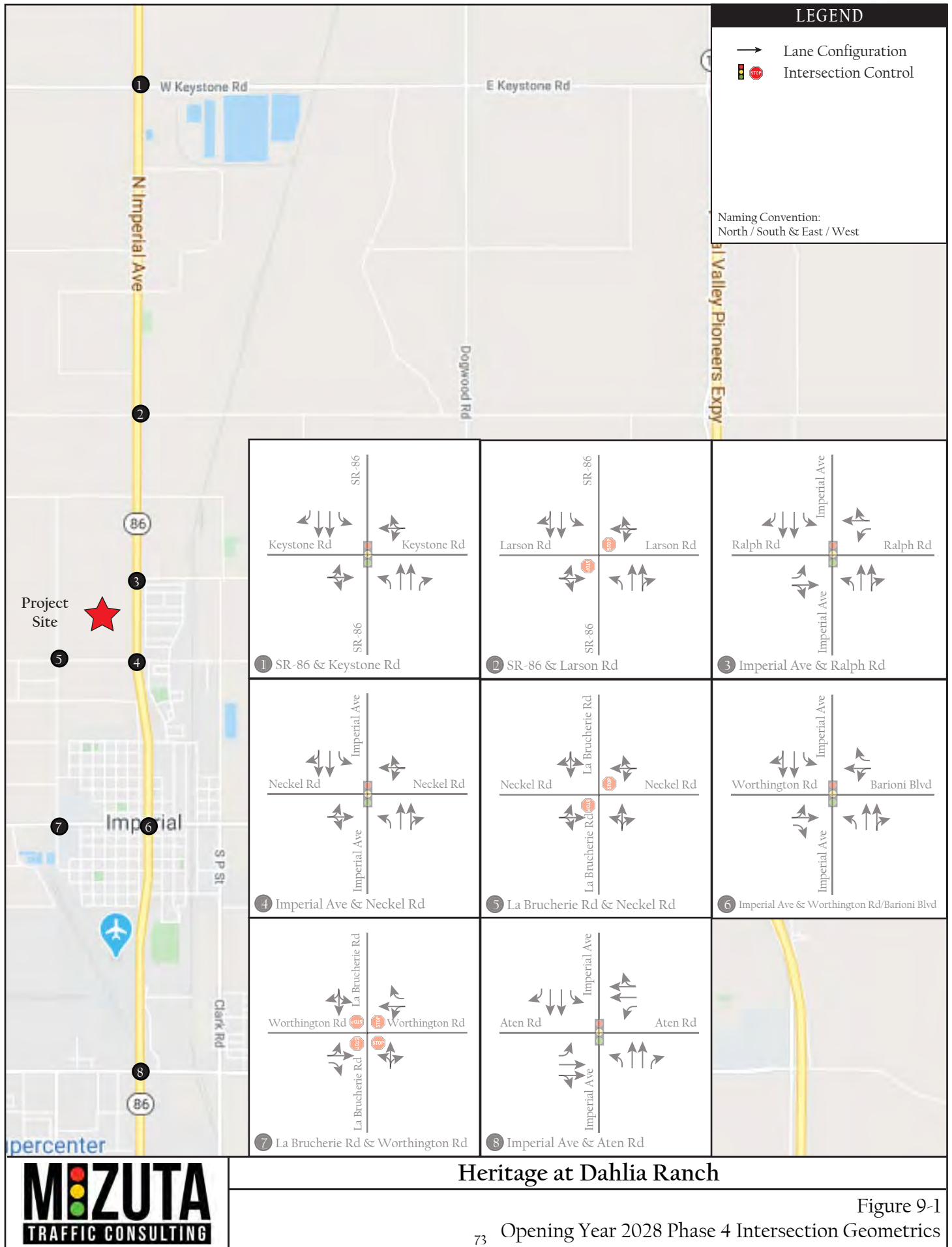

LEGEND

- Lane Configuration
- Intersection Control

Note:
Bolded values indicate roadway improvements associated with the respective project phase.

Naming Convention:
 North / South & East / West

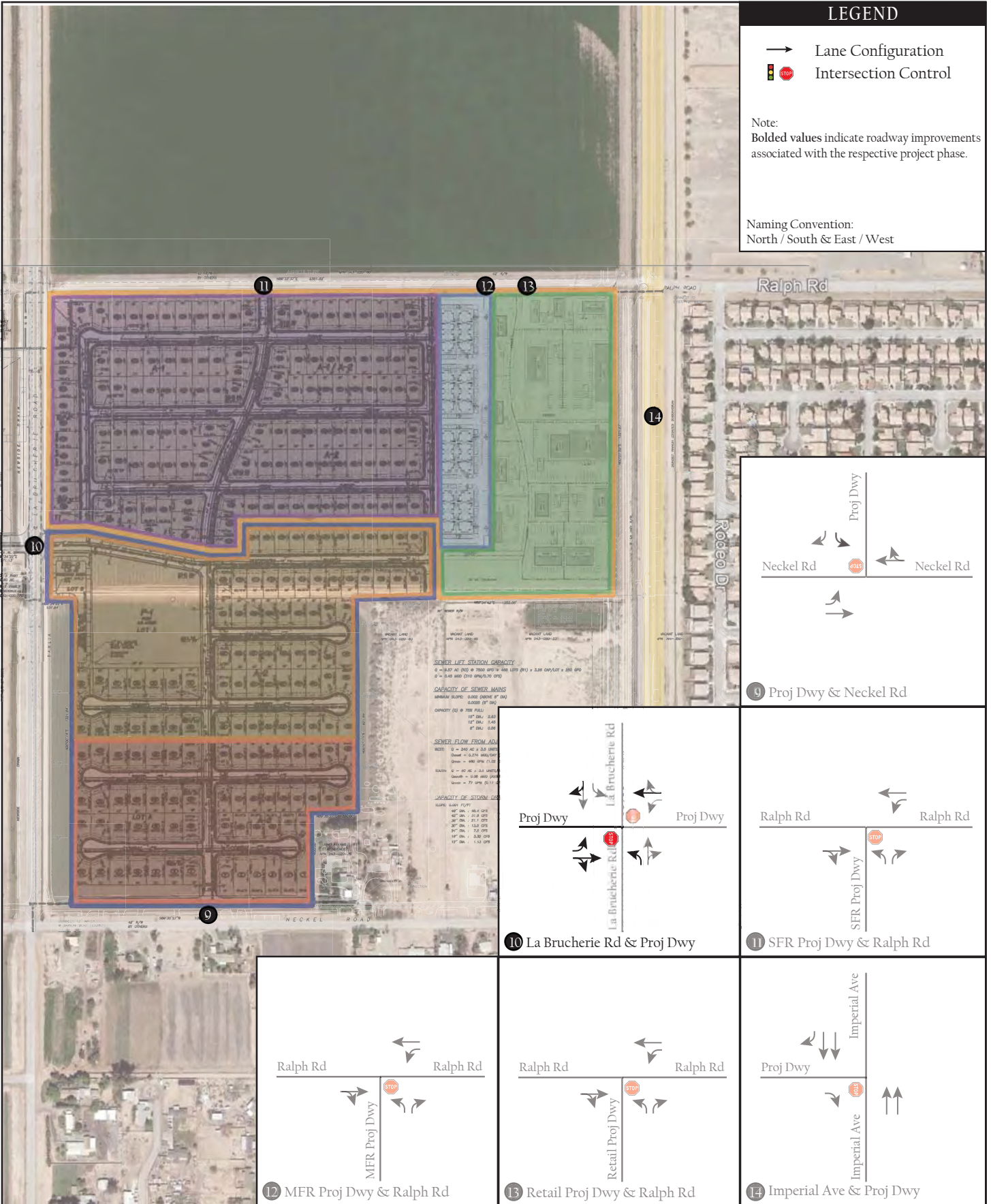

Heritage at Dahlia Ranch

Figure 9-1a

Opening Year 2028 Phase 4 Intersection Geometrics

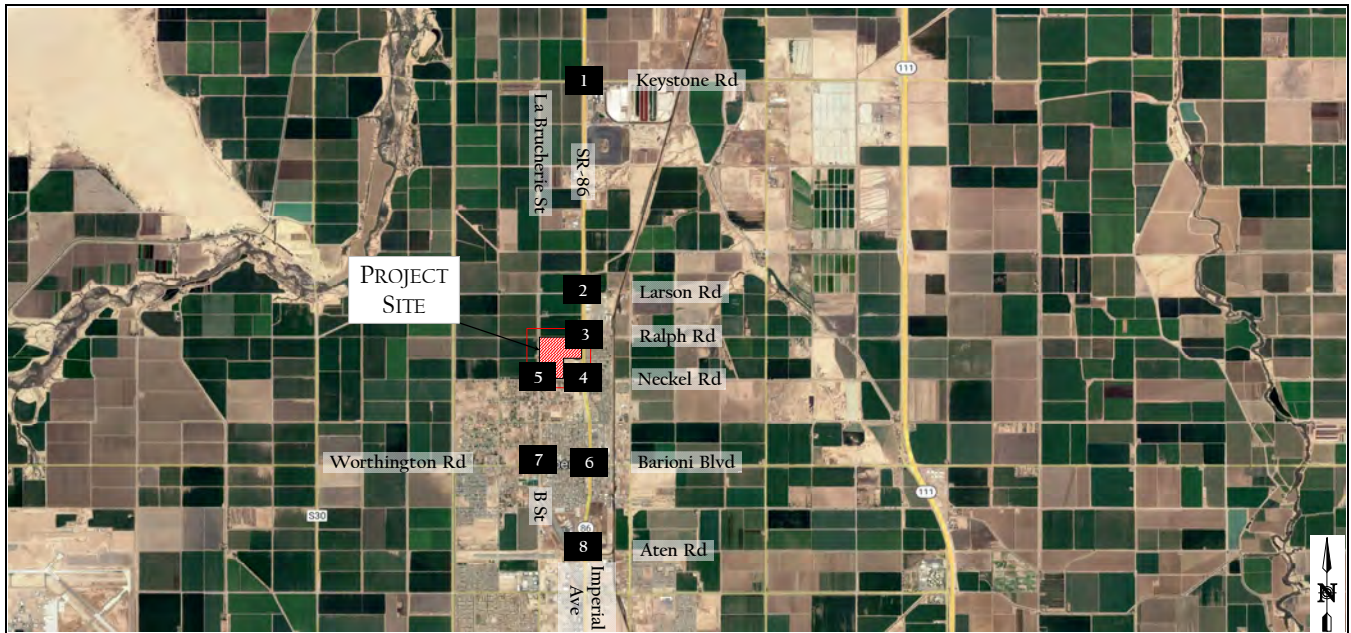

xx / yy - AM / PM Peak-Hour Turning Movement Volumes
 The naming convention for intersections is North / South & East / West

SR-86 & Keystone Rd		SR-86 & Larsen Rd		Imperial Ave & Ralph Rd		Imperial Ave & Neckel Rd	
40 / 36 ↘ ↙ 564 / 632 ↘ ↙ 48 / 56 ↘ ↙ 1	↘ ↙ 45 / 40 ↘ ↙ 25 / 29 ↘ ↙ 20 / 35	8 / 19 ↘ ↙ 569 / 670 ↘ ↙ 1 / 7 ↘ ↙ 2	↘ ↙ 6 / 6 ↘ ↙ 2 / 0 ↘ ↙ 1 / 8	545 / 611 ↘ ↙ 27 / 53 ↘ ↙ 3	↘ ↙ 45 / 23 ↘ ↙ 127 / 58	33 / 30 ↘ ↙ 612 / 568 ↘ ↙ 24 / 61 ↘ ↙ 4	↘ ↙ 87 / 68 ↘ ↙ 68 / 21 ↘ ↙ 232 / 141
35 / 44 ↘ ↙ 35 / 13 ↘ ↙ 12 / 21 ↘ ↙ 5	↘ ↙ 20 / 11 ↘ ↙ 519 / 591 ↘ ↙ 53 / 28	21 / 7 ↘ ↙ 3 / 4 ↘ ↙ 2 / 0 ↘ ↙ 6	0 / 1 ↘ ↙ 632 / 590 ↘ ↙ 1 / 8	546 / 621 ↘ ↙ 63 / 96 ↘ ↙ 7	36 / 13 ↘ ↙ 46 / 28 ↘ ↙ 13 / 4 ↘ ↙ 8	9 / 12 ↘ ↙ 493 / 659 ↘ ↙ 96 / 180	
La Brucherie Rd & Neckel Rd		Imperial Ave & Barioni Blvd / Worthington Rd		B St / La Brucherie Rd & Worthington Rd		Imperial Ave & Aten Rd	
1 / 8 ↘ ↙ 2 / 6 ↘ ↙ 1 / 0 ↘ ↙ 5	↘ ↙ 0 / 1 ↘ ↙ 47 / 47 ↘ ↙ 64 / 24	84 / 82 ↘ ↙ 796 / 711 ↘ ↙ 42 / 29 ↘ ↙ 6	↘ ↙ 83 / 55 ↘ ↙ 141 / 120 ↘ ↙ 58 / 58	68 / 25 ↘ ↙ 33 / 6 ↘ ↙ 114 / 40 ↘ ↙ 7	↘ ↙ 83 / 36 ↘ ↙ 347 / 245 ↘ ↙ 12 / 29	426 / 239 ↘ ↙ 815 / 636 ↘ ↙ 152 / 120 ↘ ↙ 8	↘ ↙ 151 / 131 ↘ ↙ 321 / 309 ↘ ↙ 140 / 191
4 / 2 ↘ ↙ 44 / 41 ↘ ↙ 24 / 9 ↘ ↙ 5	8 / 6 ↘ ↙ 7 / 7 ↘ ↙ 45 / 11	83 / 78 ↘ ↙ 145 / 79 ↘ ↙ 227 / 112 ↘ ↙ 6	99 / 120 ↘ ↙ 537 / 843 ↘ ↙ 54 / 15	65 / 28 ↘ ↙ 426 / 227 ↘ ↙ 128 / 35 ↘ ↙ 7	0 / 1 ↘ ↙ 1 / 0	208 / 229 ↘ ↙ 362 / 295 ↘ ↙ 67 / 73 ↘ ↙ 8	65 / 84 ↘ ↙ 399 / 814 ↘ ↙ 72 / 160

	<p>Heritage at Dahlia Ranch</p> <p>Opening Year 2028 Baseline Traffic Volumes</p>	<p>Figure 9-2</p>
--	---	-------------------

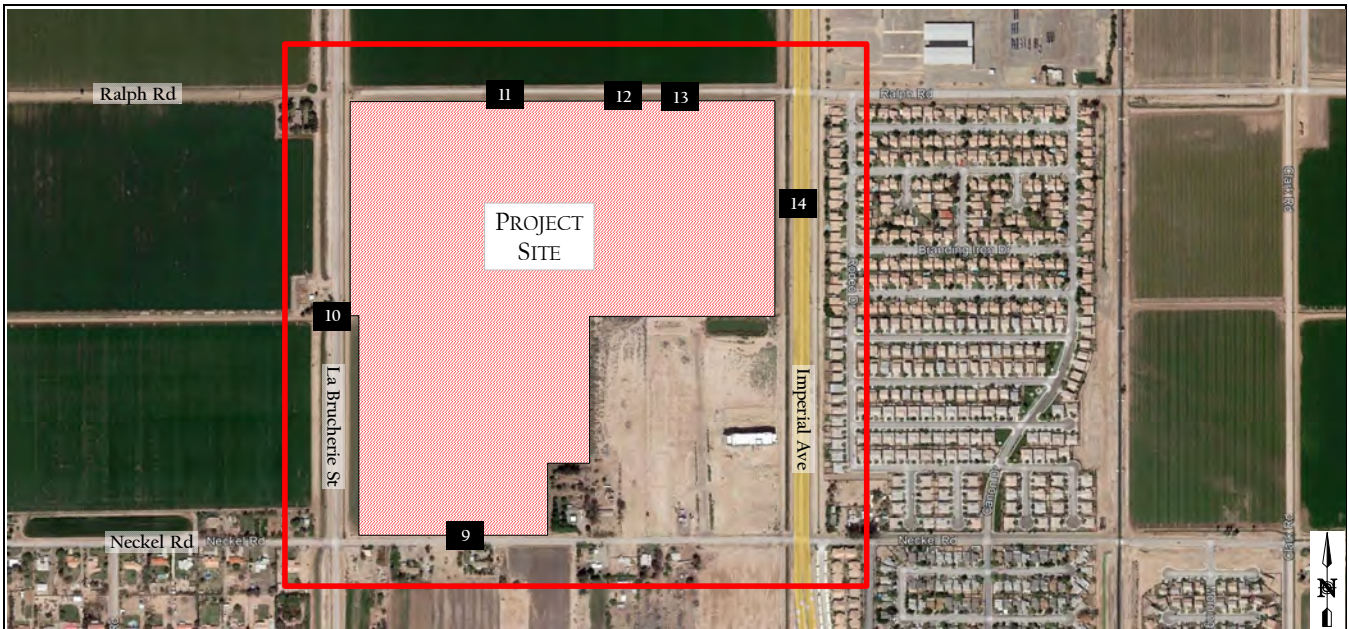

xx / yy - AM / PM Peak-Hour Turning Movement Volumes
 The naming convention for intersections is North / South & East / West

Proj Dwy & Neckel Rd	La Brucherie Rd & Proj Dwy	SFR Proj Dwy & Ralph Rd	MFR Proj Dwy & Ralph Rd
Does not exist	Does not exist	Does not exist	Does not exist
Retail Proj Dwy & Ralph Rd	Imperial Ave & Proj Dwy		
Does not exist	Does not exist		



Heritage at Dahlia Ranch
 Opening Year 2028 Baseline Traffic Volumes

Figure 9-2a

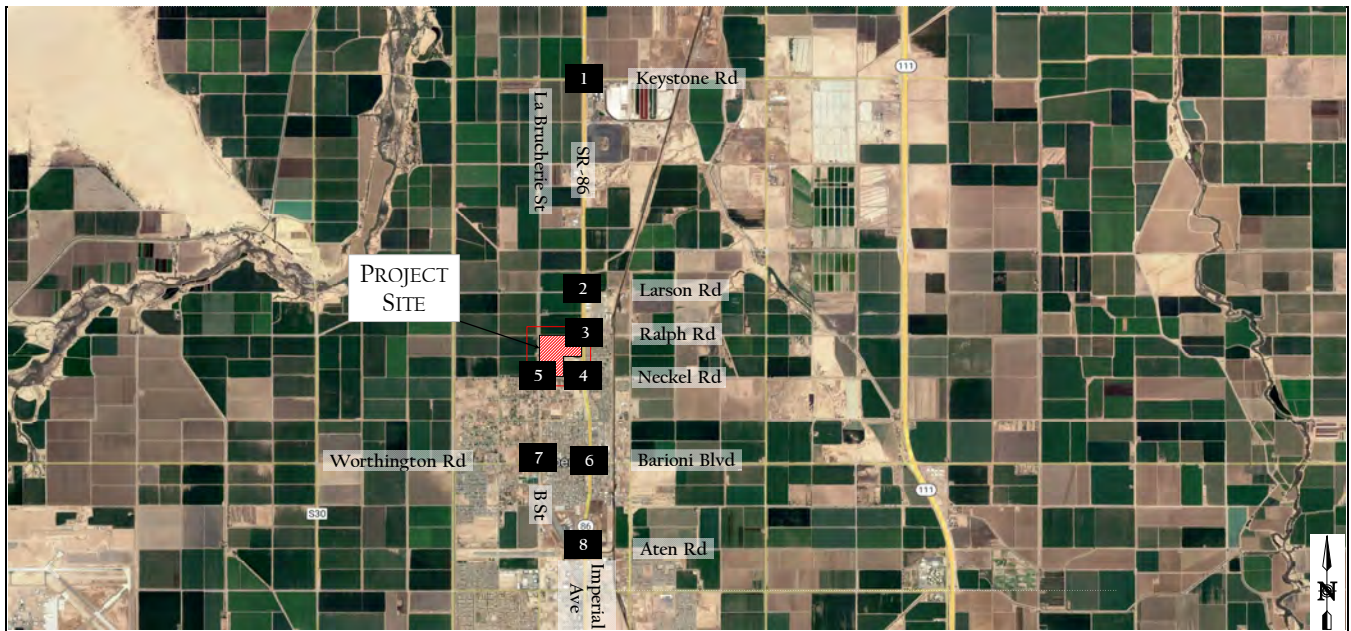

xx / yy - AM / PM Peak-Hour Turning Movement Volumes
 The naming convention for intersections is North / South & East / West

SR-86 & Keystone Rd		SR-86 & Larsen Rd		Imperial Ave & Ralph Rd		Imperial Ave & Neckel Rd	
40 / 36 ↘ ↙ 620 / 734 ↘ ↙ 48 / 56 ↘ ↙ 45 / 40 ↘ ↙ 25 / 29 ↘ ↙ 20 / 35	1	8 / 19 ↘ ↙ 625 / 772 ↘ ↙ 1 / 7 ↘ ↙ 6 / 6 ↘ ↙ 2 / 0 ↘ ↙ 1 / 8	2	39 / 84 ↘ ↙ 362 / 629 ↘ ↙ 27 / 53 ↘ ↙ 45 / 23 ↘ ↙ 17 / 18 ↘ ↙ 127 / 58	3	33 / 30 ↘ ↙ 750 / 723 ↘ ↙ 35 / 83 ↘ ↙ 104 / 86 ↘ ↙ 68 / 21 ↘ ↙ 232 / 141	4
35 / 44 ↘ ↙ 35 / 13 ↘ ↙ 12 / 21 ↘ ↙ 20 / 11 ↘ ↙ 601 / 672 ↘ ↙ 53 / 28		21 / 7 ↘ ↙ 3 / 4 ↘ ↙ 2 / 0 ↘ ↙ 0 / 1 ↘ ↙ 672 / 713 ↘ ↙ 1 / 8		82 / 81 ↘ ↙ 11 / 22 ↘ ↙ 106 / 90 ↘ ↙ 134 / 192 ↘ ↙ 546 / 621 ↘ ↙ 63 / 96		36 / 13 ↘ ↙ 46 / 28 ↘ ↙ 143 / 90 ↘ ↙ 54 / 159 ↘ ↙ 610 / 834 ↘ ↙ 96 / 180	
La Brucherie Rd & Neckel Rd		Imperial Ave & Barioni Blvd / Worthington Rd		B St / La Brucherie Rd & Worthington Rd		Imperial Ave & Aten Rd	
1 / 8 ↘ ↙ 36 / 42 ↘ ↙ 155 / 146 ↘ ↙ 94 / 193 ↘ ↙ 47 / 47 ↘ ↙ 71 / 29	5	84 / 82 ↘ ↙ 1022 / 910 ↘ ↙ 84 / 70 ↘ ↙ 111 / 107 ↘ ↙ 141 / 120 ↘ ↙ 58 / 58	6	110 / 66 ↘ ↙ 33 / 6 ↘ ↙ 114 / 40 ↘ ↙ 83 / 36 ↘ ↙ 347 / 245 ↘ ↙ 12 / 29	7	468 / 280 ↘ ↙ 959 / 755 ↘ ↙ 194 / 161 ↘ ↙ 179 / 183 ↘ ↙ 321 / 309 ↘ ↙ 140 / 191	8
4 / 2 ↘ ↙ 44 / 41 ↘ ↙ 24 / 9 ↘ ↙ 8 / 6 ↘ ↙ 33 / 50 ↘ ↙ 48 / 19		83 / 78 ↘ ↙ 145 / 79 ↘ ↙ 227 / 112 ↘ ↙ 99 / 120 ↘ ↙ 670 / 1114 ↘ ↙ 54 / 15		93 / 80 ↘ ↙ 426 / 227 ↘ ↙ 128 / 35 ↘ ↙ 0 / 1 ↘ ↙ 1 / 0		236 / 281 ↘ ↙ 362 / 295 ↘ ↙ 67 / 73 ↘ ↙ 65 / 84 ↘ ↙ 475 / 982 ↘ ↙ 72 / 160	

	Heritage at Dahlia Ranch Opening Year 2028 Plus Phases 1 to 4 Project Traffic Volumes	Figure 9-3
--	---	------------

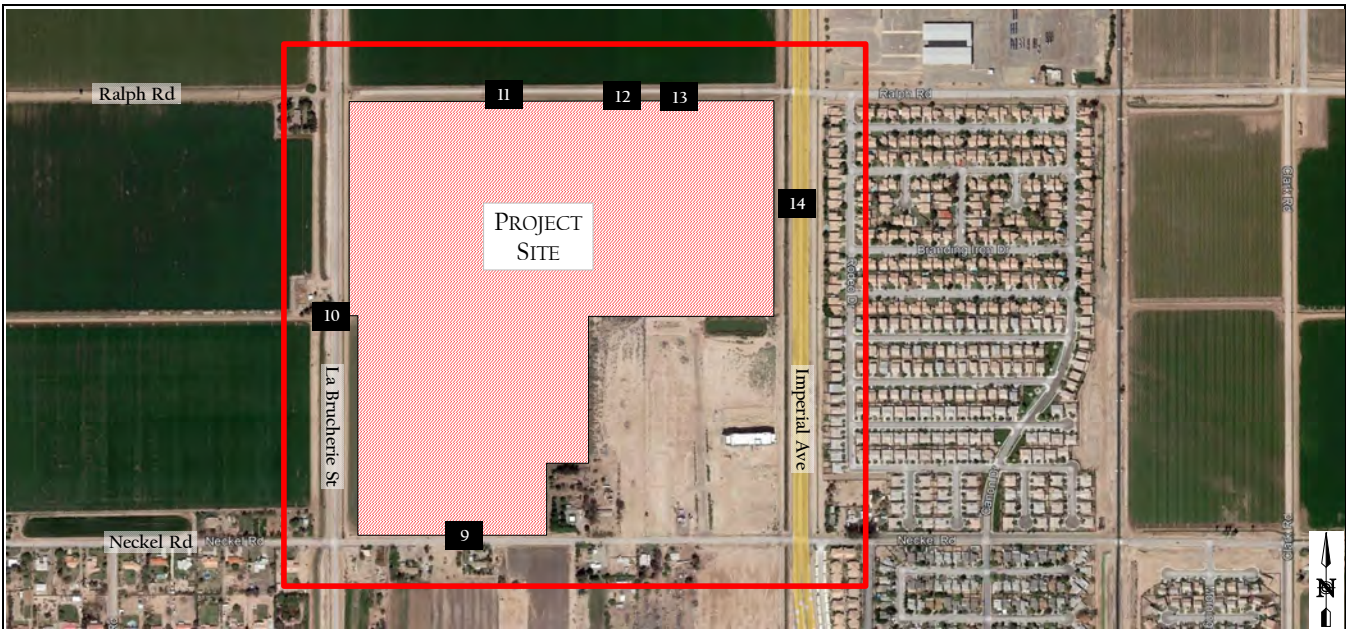

xx / yy - AM / PM Peak-Hour Turning Movement Volumes
 The naming convention for intersections is North / South & East / West

Proj Dwy & Neckel Rd	La Brucherie Rd & Proj Dwy	SFR Proj Dwy & Ralph Rd	MFR Proj Dwy & Ralph Rd
<p>7 / 5</p> <p>52 / 34</p> <p>18 / 59</p> <p>137 / 151</p> <p>9</p> <p>3 / 8</p> <p>174 / 97</p>	<p>8 / 25</p> <p>32 / 51</p> <p>7 / 5</p> <p>10</p> <p>22 / 15</p> <p>90 / 59</p> <p>30 / 101</p> <p>43 / 48</p> <p>3 / 8</p>	<p>36 / 63</p> <p>28 / 92</p> <p>11</p> <p>54 / 53</p> <p>81 / 53</p>	<p>59 / 153</p> <p>16 / 33</p> <p>12</p> <p>133 / 102</p> <p>2 / 4</p> <p>5 / 2</p> <p>42 / 17</p>
Retail Proj Dwy & Ralph Rd	Imperial Ave & Proj Dwy		
<p>52 / 150</p> <p>242 / 270</p> <p>13</p> <p>145 / 85</p> <p>30 / 34</p> <p>23 / 36</p> <p>116 / 180</p>	<p>30 / 34</p> <p>730 / 721</p> <p>14</p> <p>92 / 144</p> <p>775 / 922</p>		



Heritage at Dahlia Ranch
 Opening Year 2028 Plus Phases 1 to 4 Project Traffic Volumes

Figure 9-3a

Table 9-1
Opening Year 2028 Peak Hour Intersection LOS Summary

#	Intersection	Traffic Control	Peak Hour	Opening Year 2028		Opening Year 2028 w/Phases 1 to 4 Proj		Δ in Delay	Improvement?
				Delay ¹	LOS ²	Delay ¹	LOS ²		
1	SR-86 & Keystone Rd	Signal	AM	9.4	A	9.4	A	0.0	No
			PM	9.4	A	9.5	A	0.1	No
2	SR-86 & Larson Rd	TWSC	AM	16.3	C	17.6	C	1.3	No
			PM	19.1	C	21.6	C	2.5	No
3	Imperial Ave & Ralph Rd	Signal	AM	40.3	E	19.6	B	-20.7	No
			PM	34.0	D	24.1	C	-9.9	No
4	Imperial Ave & Neckel Rd	Signal	AM	24.9	C	50.1	D	25.2	No
			PM	20.4	C	54.0	D	33.6	No
5	La Brucherie Rd & Neckel Rd	TWSC	AM	10.4	B	20.7	C	10.3	No
			PM	9.8	A	15.5	C	5.7	No
6	Imperial Ave & Worthington Rd/Barioni Blvd	Signal	AM	42.9	D	48.4	D	5.5	No
			PM	28.3	C	33.3	C	5.0	No
7	La Brucherie Rd & Worthington Rd	AWSC	AM	25.7	D	34.2	D	8.5	No
			PM	11.7	B	13.3	B	1.6	No
8	Imperial Ave & Aten Rd	Signal	AM	40.2	D	51.6	D	11.4	No
			PM	31.2	C	52.8	D	21.6	No
9	Proj Dwy & Neckel Rd	OWSC	AM	DNE		10.9	B	10.9	No
			PM	DNE		10.5	B	10.5	No
10	La Brucherie Rd & Proj Dwy	TWSC	AM	DNE		10.4	B	10.4	No
			PM	DNE		12.1	B	12.1	No
11	SFR Proj Dwy & Ralph Rd	OWSC	AM	DNE		8.9	A	8.9	No
			PM	DNE		8.8	A	8.8	No
12	MFR Proj Dwy & Ralph Rd	OWSC	AM	DNE		9.3	A	9.3	No
			PM	DNE		10.7	B	10.7	No
13	Retail Proj Dwy & Ralph Rd	OWSC	AM	DNE		11.2	B	11.2	No
			PM	DNE		11.7	B	11.7	No
14	Imperial Ave & Proj Dwy	OWSC	AM	DNE		12.2	B	12.2	No
			PM	DNE		13.0	B	13.0	No

Notes:

OWSC: One-Way Stopped Control, TWSC: Two-Way Stopped Control, AWSC: All-Way Stopped Control

1. Delays are reported as the average control delay for the entire intersection at signalized intersections and the worst movement at unsignalized intersections.

2. LOS calculations are based on the methodology outlined in the *Highway Capacity Manual 6th Edition (HCM6)* and performed using Synchro II.

As shown in the table, all intersections, including the project driveways, are expected to operate at LOS D or better during the weekday peak-hours with the addition of the Project traffic. As a result, no additional intersection improvements are required and/or recommended.

9.4 Roadway Segment Analysis

Table 9-2 displays the LOS analysis for the study area roadway segments under the Opening Year 2028 with and without the Phase 4 Project traffic.

Table 9-2
Opening Year 2028 Roadway LOS Summary

Roadway Segment	Opening Year 2028			Opening Year 2028 w/Phases 1 to 4 Proj			Δ in V/C	Improvement?
	ADT	v/c Ratio	LOS	ADT	v/c Ratio	LOS		
SR-86								
North of Keystone Rd	17,233	0.47	B	19,338	0.52	B	0.057	No
Keystone Rd to Larsen Rd	16,491	0.45	B	18,596	0.50	B	0.057	No
Larsen Rd to Ralph Rd	15,881	0.43	B	17,986	0.49	B	0.057	No
Imperial Ave								
Ralph Rd to Neckel Rd	17,206	0.47	B	22,392	0.61	B	0.140	No
Neckel Rd to Worthington Rd	22,607	0.61	B	28,334	0.77	C	0.155	No
Worthington Rd to Aten Rd	24,181	0.65	B	29,295	0.79	C	0.138	No
South of Aten Rd	25,224	0.68	C	28,231	0.76	C	0.081	No

As shown in the table, all roadway segments would continue to function at LOS C or better with the addition of the project traffic. As a result, no additional improvements are required and/or recommended.

10 SUMMARY OF FINDINGS AND RECOMMENDATIONS

The following list summarizes the key findings for the Project:

- The Project consists of constructing 266 single family residential detached housing, 200 apartment units, and 92,120 sf of various commercial/retail uses on the vacant site generally bounded by Neckel Road to the north, Ralph Road to the south, Imperial Avenue to the east, and La Brucherie Road to the west.
- The project would be constructed over four phases.
 - Phase 1: 133 single family residential units (Year 2023)
 - Phase 2: 133 single family residential units (Year 2024)
 - Phase 3: 200 apartment units and 92,120 square feet (sf) of various commercial/retail (Year 2026)
 - Phase 4: 202 single family residential units (Year 2028)
- In Phase 1, the Project will construct an eastbound left-turn lane at the Project driveway off Neckel Road.
- In Phase 2, the Project will construct a southbound left-turn lane at the Project driveway off La Brucherie Road.
- In Phase 3, the Project will construct and extend Ralph Road west from Imperial Avenue until La Brucherie Road. The Imperial Avenue & Ralph Road intersection will be upgraded to include a traffic signal. The Project will construct a westbound left-turn lane along Ralph Road for entering traffic to access the multi-family and commercial/retail uses. Additionally, a southbound right-turn deceleration lane will be constructed at the new driveway along Imperial Highway.
- In Phase 4, the Project will construct the west leg of the La Brucherie Road & Project Driveway intersection. The Project will also construct a northbound left-turn lane along La Brucherie Road for entering traffic.
- The Project is forecasted to generate 11,785 daily trips with 691 AM peak-hour trips and 916 PM peak-hour trips at the project driveways.
- The Clark 54 cumulative project was added to the baseline traffic volumes and included in the analyses.
- All intersections, roadway segments, and the project driveways in the study area are expected to operate at an acceptable LOS D or better under all scenarios.

This traffic study has been prepared in accordance with the *County of Imperial Department of Public Works Traffic Study and Report Policy, June 29, 2007*. The proposed Project will not result in any deficient facilities in the study area and no improvements other than the ones listed above are required or recommended of the proposed Project.

Appendix A

SR-86 Relinquishment Map

STATE OF CALIFORNIA
 DEPARTMENT OF TRANSPORTATION

RELINQUISHMENT OF
 STATE HIGHWAY 86

IN IMPERIAL COUNTY, CITY OF IMPERIAL
 FROM TRESHILL ROAD TO RALPH ROAD

James W. Lindsey
 DISTRICT 11 RIGHT OF WAY ENGINEER
 DATE: Oct. 24 2016
 PROFESSIONAL LAND SURVEYOR
 L.S. 8355
 Exp. 12/31/2017
 STATE OF CALIFORNIA



NOTE:
 STATE'S RIGHTS ARE NOT EXTINGUISHED UNTIL
 RECORDATION OF RELATED CTC RESOLUTION.

CALIFORNIA TRANSPORTATION COMMISSION
 RESOLUTION DATE: 12-07-2016
 CTC NO.: R-3974

CTC RESOLUTION RECORDING DATA
 REC. DATE: 01-10-2017
 FILE NO.: 2017000522

STATE HIGHWAY MAP RECORDING DATA
 BOOK 5 PAGES 54
 FILE NO: 2016 022 081
 FILE AT THE REQUEST OF THE CALIFORNIA STATE
 TRANSPORTATION AGENCY, DEPARTMENT OF
 TRANSPORTATION, DISTRICT 11.

THIS 26TH DAY OF OCTOBER 20 16, AT 10:31 AM

COUNTY RECORDER FEE: 0
 CHUCK STOREY, COUNTY RECORDER

BY: *Chuck Storey*
 DEPUTY COUNTY RECORDER

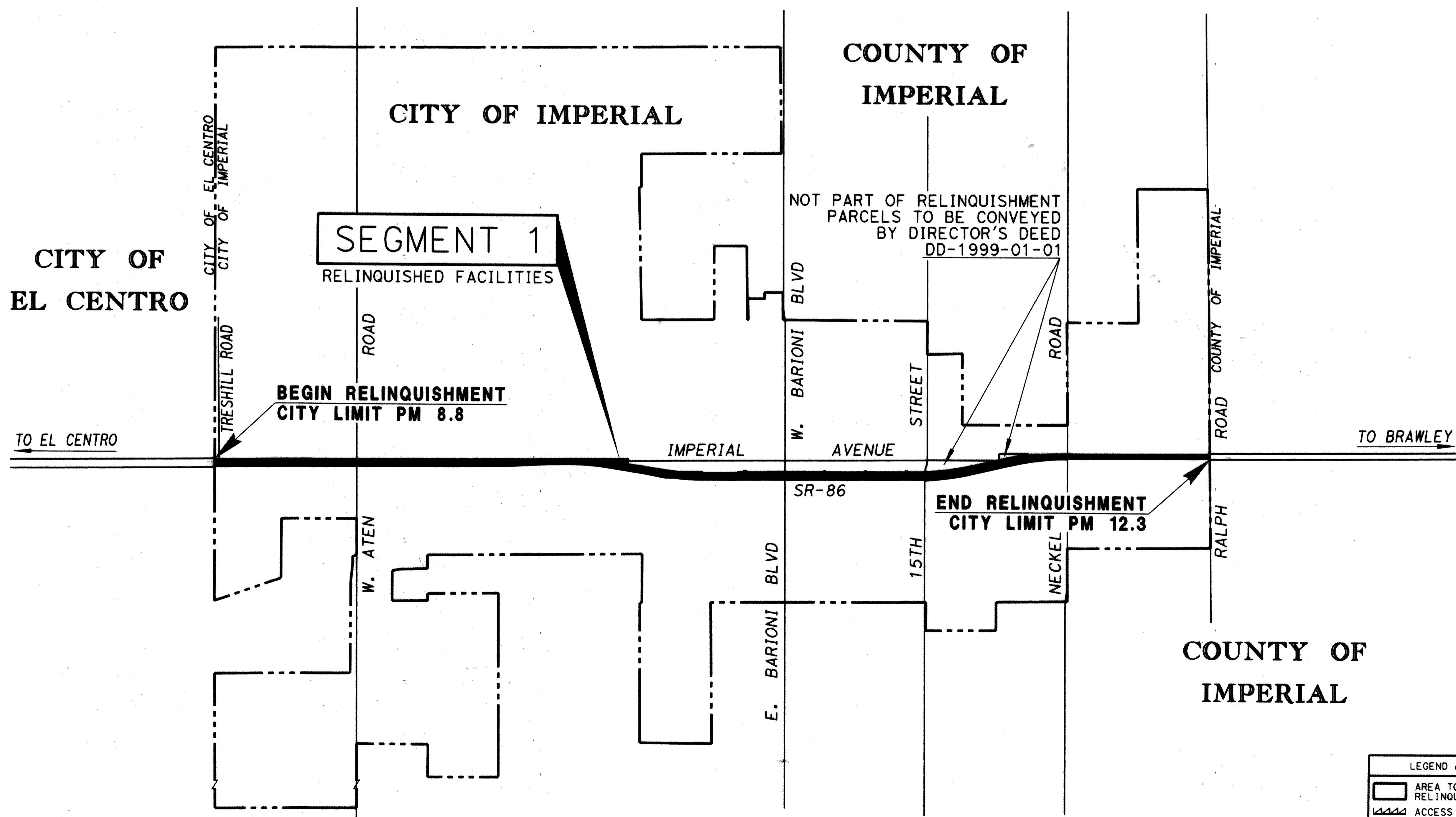

LEGEND & NOTES

- AREA TO BE RELINQUISHED
- ACCESS RELINQUISHED
- ACCESS DENIED
- ACCESS OPENING

P.N.: 1114000050
 E.A.:

STATE OF CALIFORNIA
 DEPARTMENT OF TRANSPORTATION
 DISTRICT 11

**RELINQUISHMENT
 MAP**

Relinquishment No. **R31136**

RIGHT OF WAY MAP NO.		SCALE	
COUNTY ROUTE	POST MILE	1" = 1000'	
IM 86	8.8 - 12.3		
		SHEET 1 OF 2	

Appendix B

Existing Traffic Volume Data

County of Imperial
 N/S: SR-86
 E/W: Keystone Road
 Weather: Clear

File Name : 01_CIM_SR-86_Keystone AM
 Site Code : 99921570
 Start Date : 10/13/2021
 Page No : 1

Groups Printed- Total Volume

Start Time	SR-86 Southbound				Keystone Road Westbound				SR-86 Northbound				Keystone Road Eastbound				Int. Total
	Left	Thru	Right	App. Total	Left	Thru	Right	App. Total	Left	Thru	Right	App. Total	Left	Thru	Right	App. Total	
07:00 AM	6	84	5	95	6	2	5	13	2	93	8	103	8	10	0	18	229
07:15 AM	10	124	10	144	0	5	3	8	7	115	11	133	8	8	4	20	305
07:30 AM	18	130	10	158	6	6	14	26	4	108	16	128	14	8	1	23	335
07:45 AM	10	125	8	143	7	6	12	25	6	132	15	153	9	11	0	20	341
Total	44	463	33	540	19	19	34	72	19	448	50	517	39	37	5	81	1210
08:00 AM	6	119	8	133	5	6	12	23	1	72	6	79	1	5	6	12	247
08:15 AM	6	88	5	99	7	4	8	19	3	103	6	112	9	2	3	14	244
08:30 AM	8	84	5	97	9	7	12	28	0	82	6	88	6	5	2	13	226
08:45 AM	6	90	7	103	3	0	14	17	1	91	4	96	6	4	1	11	227
Total	26	381	25	432	24	17	46	87	5	348	22	375	22	16	12	50	944
Grand Total	70	844	58	972	43	36	80	159	24	796	72	892	61	53	17	131	2154
Apprch %	7.2	86.8	6		27	22.6	50.3		2.7	89.2	8.1		46.6	40.5	13		
Total %	3.2	39.2	2.7	45.1	2	1.7	3.7	7.4	1.1	37	3.3	41.4	2.8	2.5	0.8	6.1	

Start Time	SR-86 Southbound				Keystone Road Westbound				SR-86 Northbound				Keystone Road Eastbound				Int. Total
	Left	Thru	Right	App. Total	Left	Thru	Right	App. Total	Left	Thru	Right	App. Total	Left	Thru	Right	App. Total	
07:15 AM	10	124	10	144	0	5	3	8	7	115	11	133	8	8	4	20	305
07:30 AM	18	130	10	158	6	6	14	26	4	108	16	128	14	8	1	23	335
07:45 AM	10	125	8	143	7	6	12	25	6	132	15	153	9	11	0	20	341
08:00 AM	6	119	8	133	5	6	12	23	1	72	6	79	1	5	6	12	247
Total Volume	44	498	36	578	18	23	41	82	18	427	48	493	32	32	11	75	1228
% App. Total	7.6	86.2	6.2		22	28	50		3.7	86.6	9.7		42.7	42.7	14.7		
PHF	.611	.958	.900	.915	.643	.958	.732	.788	.643	.809	.750	.806	.571	.727	.458	.815	.900

Peak Hour Analysis From 07:00 AM to 08:45 AM - Peak 1 of 1
 Peak Hour for Entire Intersection Begins at 07:15 AM

County of Imperial
 N/S: SR-86
 E/W: Keystone Road
 Weather: Clear

File Name : 01_CIM_SR-86_Keystone AM
 Site Code : 99921570
 Start Date : 10/13/2021
 Page No : 2

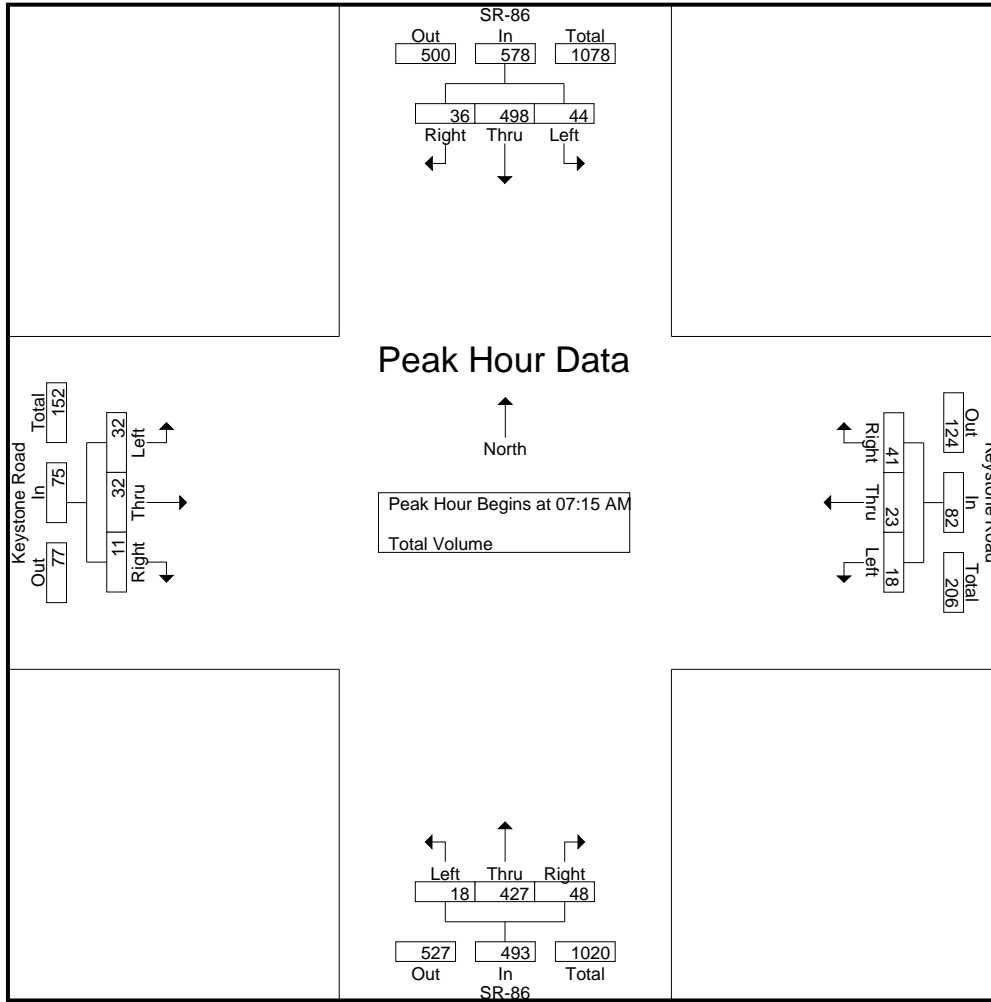

Peak Hour Analysis From 07:00 AM to 08:45 AM - Peak 1 of 1
 Peak Hour for Each Approach Begins at:

	07:15 AM				07:45 AM				07:00 AM				07:00 AM			
+0 mins.	10	124	10	144	7	6	12	25	2	93	8	103	8	10	0	18
+15 mins.	18	130	10	158	5	6	12	23	7	115	11	133	8	8	4	20
+30 mins.	10	125	8	143	7	4	8	19	4	108	16	128	14	8	1	23
+45 mins.	6	119	8	133	9	7	12	28	6	132	15	153	9	11	0	20
Total Volume	44	498	36	578	28	23	44	95	19	448	50	517	39	37	5	81
% App. Total	7.6	86.2	6.2		29.5	24.2	46.3		3.7	86.7	9.7		48.1	45.7	6.2	
PHF	.611	.958	.900	.915	.778	.821	.917	.848	.679	.848	.781	.845	.696	.841	.313	.880

County of Imperial
 N/S: SR-86
 E/W: Keystone Road
 Weather: Clear

File Name : 01_CIM_SR-86_Keystone PM
 Site Code : 99921570
 Start Date : 10/13/2021
 Page No : 1

Groups Printed- Total Volume

Start Time	SR-86 Southbound				Keystone Road Westbound				SR-86 Northbound				Keystone Road Eastbound				Int. Total
	Left	Thru	Right	App. Total	Left	Thru	Right	App. Total	Left	Thru	Right	App. Total	Left	Thru	Right	App. Total	
04:00 PM	7	116	8	131	7	6	7	20	4	108	5	117	9	3	1	13	281
04:15 PM	10	122	8	140	4	8	14	26	5	124	4	133	7	2	8	17	316
04:30 PM	9	108	7	124	7	7	15	29	3	103	6	112	10	2	4	16	281
04:45 PM	16	135	12	163	13	6	7	26	3	138	5	146	13	3	8	24	359
Total	42	481	35	558	31	27	43	101	15	473	20	508	39	10	21	70	1237
05:00 PM	13	126	8	147	6	6	5	17	1	133	7	141	1	2	3	6	311
05:15 PM	13	158	6	177	6	7	9	22	3	135	7	145	16	5	4	25	369
05:30 PM	9	115	5	129	6	2	10	18	2	112	4	118	9	1	0	10	275
05:45 PM	4	71	7	82	6	4	11	21	4	148	5	157	3	1	2	6	266
Total	39	470	26	535	24	19	35	78	10	528	23	561	29	9	9	47	1221
Grand Total	81	951	61	1093	55	46	78	179	25	1001	43	1069	68	19	30	117	2458
Apprch %	7.4	87	5.6		30.7	25.7	43.6		2.3	93.6	4		58.1	16.2	25.6		
Total %	3.3	38.7	2.5	44.5	2.2	1.9	3.2	7.3	1	40.7	1.7	43.5	2.8	0.8	1.2	4.8	

Start Time	SR-86 Southbound				Keystone Road Westbound				SR-86 Northbound				Keystone Road Eastbound				Int. Total
	Left	Thru	Right	App. Total	Left	Thru	Right	App. Total	Left	Thru	Right	App. Total	Left	Thru	Right	App. Total	
Peak Hour Analysis From 04:00 PM to 05:45 PM - Peak 1 of 1																	
Peak Hour for Entire Intersection Begins at 04:30 PM																	
04:30 PM	9	108	7	124	7	7	15	29	3	103	6	112	10	2	4	16	281
04:45 PM	16	135	12	163	13	6	7	26	3	138	5	146	13	3	8	24	359
05:00 PM	13	126	8	147	6	6	5	17	1	133	7	141	1	2	3	6	311
05:15 PM	13	158	6	177	6	7	9	22	3	135	7	145	16	5	4	25	369
Total Volume	51	527	33	611	32	26	36	94	10	509	25	544	40	12	19	71	1320
% App. Total	8.3	86.3	5.4		34	27.7	38.3		1.8	93.6	4.6		56.3	16.9	26.8		
PHF	.797	.834	.688	.863	.615	.929	.600	.810	.833	.922	.893	.932	.625	.600	.594	.710	.894

County of Imperial
 N/S: SR-86
 E/W: Keystone Road
 Weather: Clear

File Name : 01_CIM_SR-86_Keystone PM
 Site Code : 99921570
 Start Date : 10/13/2021
 Page No : 2

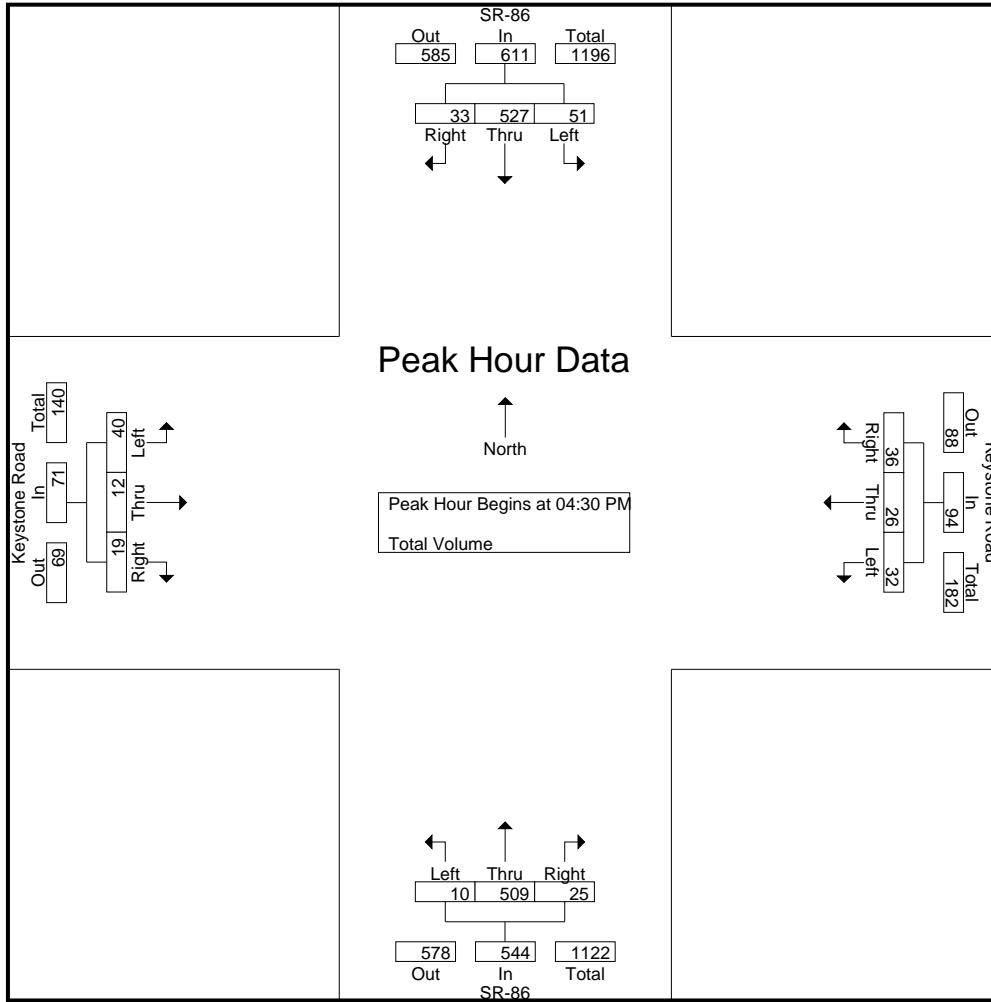

Peak Hour Analysis From 04:00 PM to 05:45 PM - Peak 1 of 1
 Peak Hour for Each Approach Begins at:

	04:45 PM				04:00 PM				05:00 PM				04:30 PM			
+0 mins.	16	135	12	163	7	6	7	20	1	133	7	141	10	2	4	16
+15 mins.	13	126	8	147	4	8	14	26	3	135	7	145	13	3	8	24
+30 mins.	13	158	6	177	7	7	15	29	2	112	4	118	1	2	3	6
+45 mins.	9	115	5	129	13	6	7	26	4	148	5	157	16	5	4	25
Total Volume	51	534	31	616	31	27	43	101	10	528	23	561	40	12	19	71
% App. Total	8.3	86.7	5		30.7	26.7	42.6		1.8	94.1	4.1		56.3	16.9	26.8	
PHF	.797	.845	.646	.870	.596	.844	.717	.871	.625	.892	.821	.893	.625	.600	.594	.710

County of Imperial
 N/S: SR-86
 E/W: Larsen Road
 Weather: Clear

File Name : 02_CIM_SR-86_Larsen AM
 Site Code : 99921570
 Start Date : 10/13/2021
 Page No : 1

Groups Printed- Total Volume

Start Time	SR-86 Southbound				Larsen Road Westbound				SR-86 Northbound				Larsen Road Eastbound				Int. Total
	Left	Thru	Right	App. Total	Left	Thru	Right	App. Total	Left	Thru	Right	App. Total	Left	Thru	Right	App. Total	
07:00 AM	0	67	0	67	0	0	1	1	1	99	1	101	7	2	0	9	178
07:15 AM	0	118	2	120	0	2	2	4	0	129	0	129	7	0	0	7	260
07:30 AM	0	128	1	129	0	0	1	1	0	142	0	142	3	1	0	4	276
07:45 AM	1	131	2	134	0	0	1	1	0	129	0	129	5	2	2	9	273
Total	1	444	5	450	0	2	5	7	1	499	1	501	22	5	2	29	987
08:00 AM	0	126	2	128	1	0	1	2	0	92	1	93	4	0	0	4	227
08:15 AM	0	95	4	99	1	1	1	3	0	98	1	99	2	2	2	6	207
08:30 AM	0	102	1	103	0	1	1	2	0	79	3	82	2	0	0	2	189
08:45 AM	0	94	0	94	0	1	0	1	1	102	1	104	4	0	0	4	203
Total	0	417	7	424	2	3	3	8	1	371	6	378	12	2	2	16	826
Grand Total	1	861	12	874	2	5	8	15	2	870	7	879	34	7	4	45	1813
Apprch %	0.1	98.5	1.4		13.3	33.3	53.3		0.2	99	0.8		75.6	15.6	8.9		
Total %	0.1	47.5	0.7	48.2	0.1	0.3	0.4	0.8	0.1	48	0.4	48.5	1.9	0.4	0.2	2.5	

Start Time	SR-86 Southbound				Larsen Road Westbound				SR-86 Northbound				Larsen Road Eastbound				Int. Total
	Left	Thru	Right	App. Total	Left	Thru	Right	App. Total	Left	Thru	Right	App. Total	Left	Thru	Right	App. Total	
07:15 AM	0	118	2	120	0	2	2	4	0	129	0	129	7	0	0	7	260
07:30 AM	0	128	1	129	0	0	1	1	0	142	0	142	3	1	0	4	276
07:45 AM	1	131	2	134	0	0	1	1	0	129	0	129	5	2	2	9	273
08:00 AM	0	126	2	128	1	0	1	2	0	92	1	93	4	0	0	4	227
Total Volume	1	503	7	511	1	2	5	8	0	492	1	493	19	3	2	24	1036
% App. Total	0.2	98.4	1.4		12.5	25	62.5		0	99.8	0.2		79.2	12.5	8.3		
PHF	.250	.960	.875	.953	.250	.250	.625	.500	.000	.866	.250	.868	.679	.375	.250	.667	.938

Peak Hour Analysis From 07:00 AM to 08:45 AM - Peak 1 of 1
 Peak Hour for Entire Intersection Begins at 07:15 AM

County of Imperial
 N/S: SR-86
 E/W: Larsen Road
 Weather: Clear

File Name : 02_CIM_SR-86_Larsen AM
 Site Code : 99921570
 Start Date : 10/13/2021
 Page No : 2

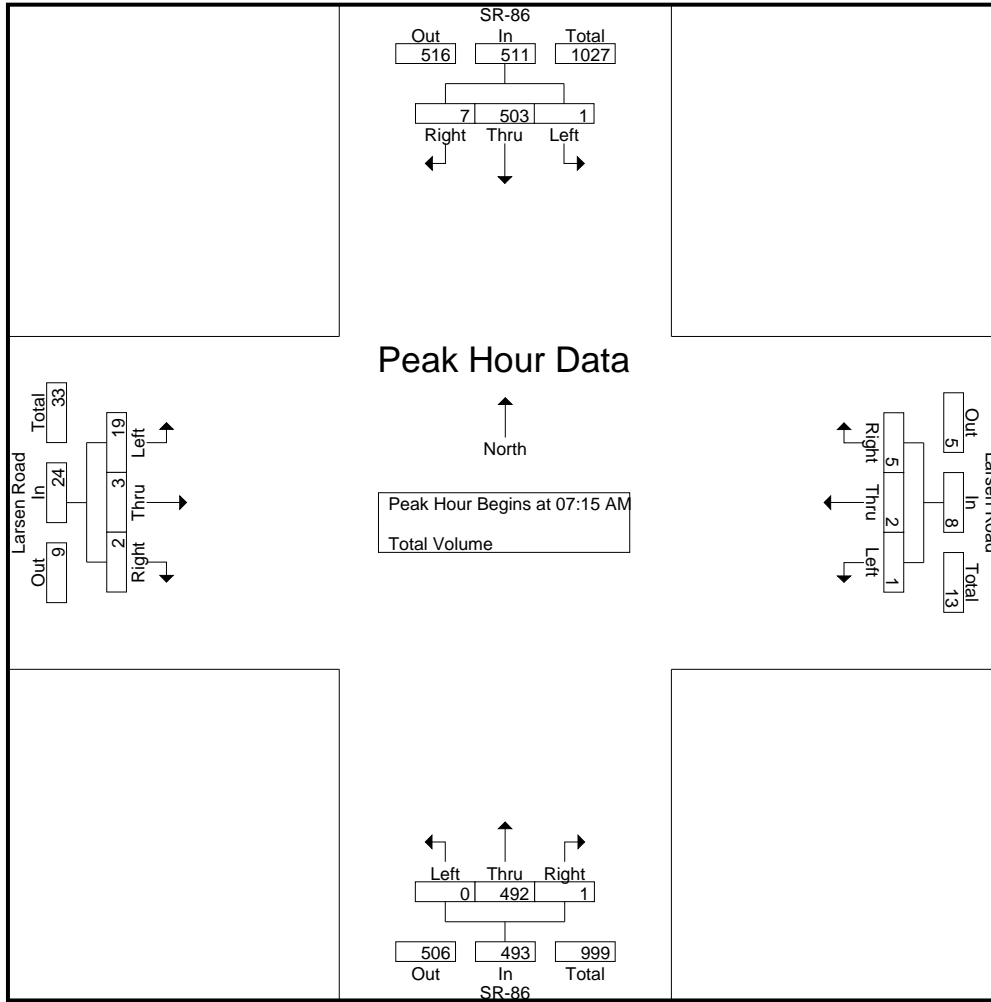

Peak Hour Analysis From 07:00 AM to 08:45 AM - Peak 1 of 1
 Peak Hour for Each Approach Begins at:

	07:15 AM				07:15 AM				07:00 AM				07:00 AM			
+0 mins.	0	118	2	120	0	2	2	4	1	99	1	101	7	2	0	9
+15 mins.	0	128	1	129	0	0	1	1	0	129	0	129	7	0	0	7
+30 mins.	1	131	2	134	0	0	1	1	0	142	0	142	3	1	0	4
+45 mins.	0	126	2	128	1	0	1	2	0	129	0	129	5	2	2	9
Total Volume	1	503	7	511	1	2	5	8	1	499	1	501	22	5	2	29
% App. Total	0.2	98.4	1.4		12.5	25	62.5		0.2	99.6	0.2		75.9	17.2	6.9	
PHF	.250	.960	.875	.953	.250	.250	.625	.500	.250	.879	.250	.882	.786	.625	.250	.806

County of Imperial
 N/S: SR-86
 E/W: Larsen Road
 Weather: Clear

File Name : 02_CIM_SR-86_Larsen PM
 Site Code : 99921570
 Start Date : 10/13/2021
 Page No : 1

Groups Printed- Total Volume

Start Time	SR-86 Southbound				Larsen Road Westbound				SR-86 Northbound				Larsen Road Eastbound				Int. Total
	Left	Thru	Right	App. Total	Left	Thru	Right	App. Total	Left	Thru	Right	App. Total	Left	Thru	Right	App. Total	
04:00 PM	1	136	6	143	1	0	1	2	1	116	1	118	1	0	0	1	264
04:15 PM	3	134	1	138	1	2	0	3	1	133	3	137	0	0	0	0	278
04:30 PM	1	127	3	131	2	1	1	4	2	113	3	118	0	2	2	4	257
04:45 PM	1	134	8	143	2	0	1	3	0	121	0	121	2	1	0	3	270
Total	6	531	18	555	6	3	3	12	4	483	7	494	3	3	2	8	1069
05:00 PM	2	154	4	160	0	0	0	0	0	154	1	155	1	1	0	2	317
05:15 PM	3	160	3	166	4	0	3	7	0	137	2	139	1	1	0	2	314
05:30 PM	0	114	2	116	1	0	1	2	1	134	4	139	2	1	0	3	260
05:45 PM	6	96	0	102	1	2	0	3	1	147	4	152	0	3	2	5	262
Total	11	524	9	544	6	2	4	12	2	572	11	585	4	6	2	12	1153
Grand Total	17	1055	27	1099	12	5	7	24	6	1055	18	1079	7	9	4	20	2222
Apprch %	1.5	96	2.5		50	20.8	29.2		0.6	97.8	1.7		35	45	20		
Total %	0.8	47.5	1.2	49.5	0.5	0.2	0.3	1.1	0.3	47.5	0.8	48.6	0.3	0.4	0.2	0.9	

Start Time	SR-86 Southbound				Larsen Road Westbound				SR-86 Northbound				Larsen Road Eastbound				Int. Total
	Left	Thru	Right	App. Total	Left	Thru	Right	App. Total	Left	Thru	Right	App. Total	Left	Thru	Right	App. Total	
04:45 PM	1	134	8	143	2	0	1	3	0	121	0	121	2	1	0	3	270
05:00 PM	2	154	4	160	0	0	0	0	0	154	1	155	1	1	0	2	317
05:15 PM	3	160	3	166	4	0	3	7	0	137	2	139	1	1	0	2	314
05:30 PM	0	114	2	116	1	0	1	2	1	134	4	139	2	1	0	3	260
Total Volume	6	562	17	585	7	0	5	12	1	546	7	554	6	4	0	10	1161
% App. Total	1	96.1	2.9		58.3	0	41.7		0.2	98.6	1.3		60	40	0		
PHF	.500	.878	.531	.881	.438	.000	.417	.429	.250	.886	.438	.894	.750	1.00	.000	.833	.916

Peak Hour Analysis From 04:00 PM to 05:45 PM - Peak 1 of 1
 Peak Hour for Entire Intersection Begins at 04:45 PM

County of Imperial
 N/S: SR-86
 E/W: Larsen Road
 Weather: Clear

File Name : 02_CIM_SR-86_Larsen PM
 Site Code : 99921570
 Start Date : 10/13/2021
 Page No : 2

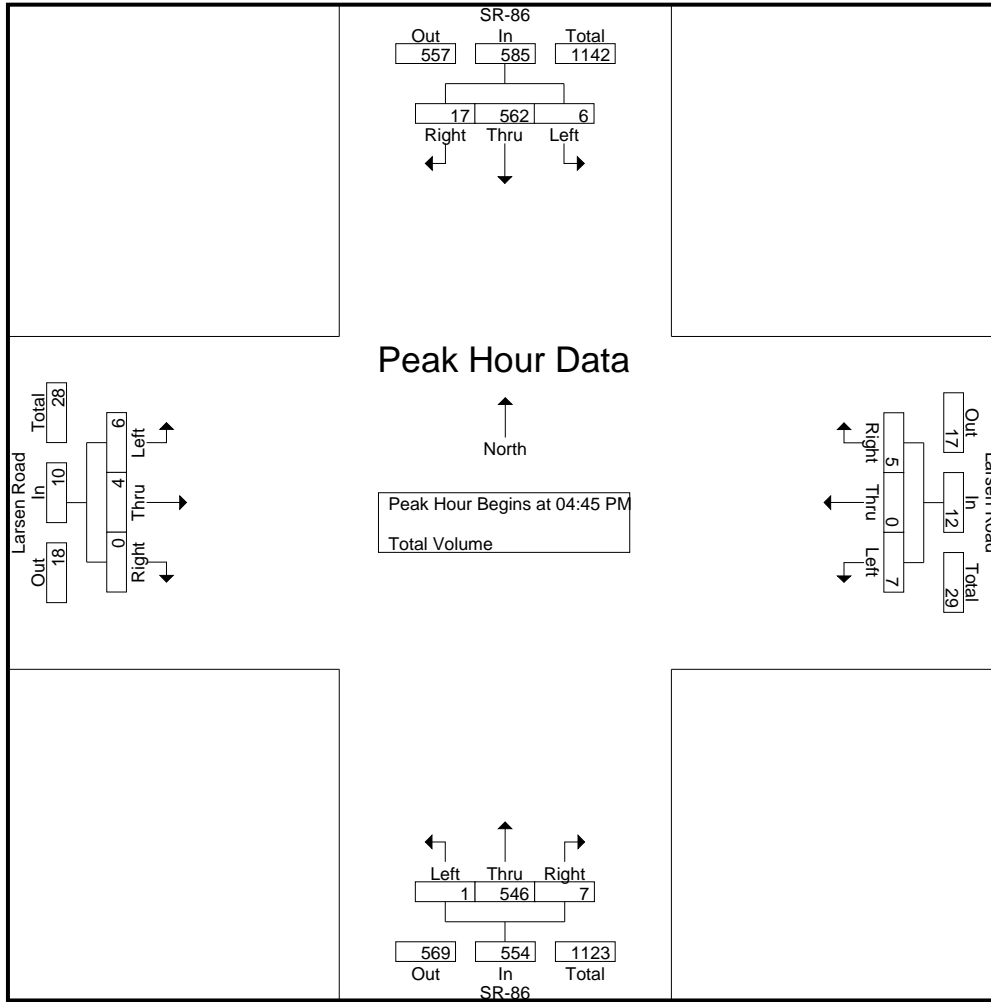

Peak Hour Analysis From 04:00 PM to 05:45 PM - Peak 1 of 1
 Peak Hour for Each Approach Begins at:

	04:30 PM				04:30 PM				05:00 PM				05:00 PM			
+0 mins.	1	127	3	131	2	1	1	4	0	154	1	155	1	1	0	2
+15 mins.	1	134	8	143	2	0	1	3	0	137	2	139	1	1	0	2
+30 mins.	2	154	4	160	0	0	0	0	1	134	4	139	2	1	0	3
+45 mins.	3	160	3	166	4	0	3	7	1	147	4	152	0	3	2	5
Total Volume	7	575	18	600	8	1	5	14	2	572	11	585	4	6	2	12
% App. Total	1.2	95.8	3		57.1	7.1	35.7		0.3	97.8	1.9		33.3	50	16.7	
PHF	.583	.898	.563	.904	.500	.250	.417	.500	.500	.929	.688	.944	.500	.500	.250	.600

City of Imperial
 N/S: SR-86
 E/W: Ralph Road
 Weather: Clear

File Name : 03_IPL_SR-86_Ralph AM
 Site Code : 99921570
 Start Date : 10/13/2021
 Page No : 1

Groups Printed- Total Volume

Start Time	SR-86 Southbound				Ralph Road Westbound				SR-86 Northbound				Ralph Road Eastbound				Int. Total
	Left	Thru	Right	App. Total	Left	Thru	Right	App. Total	Left	Thru	Right	App. Total	Left	Thru	Right	App. Total	
07:00 AM	2	65	0	67	5	0	10	15	0	86	5	91	0	0	0	0	173
07:15 AM	4	115	0	119	7	0	8	15	0	116	9	125	0	0	0	0	259
07:30 AM	7	130	0	137	16	0	4	20	0	138	6	144	0	0	0	0	301
07:45 AM	4	122	0	126	20	0	6	26	0	126	7	133	0	0	0	0	285
Total	17	432	0	449	48	0	28	76	0	466	27	493	0	0	0	0	1018
08:00 AM	4	119	0	123	14	0	4	18	0	91	18	109	0	0	0	0	250
08:15 AM	3	89	0	92	12	0	2	14	0	92	8	100	0	0	0	0	206
08:30 AM	4	101	0	105	5	0	3	8	0	79	3	82	0	0	0	0	195
08:45 AM	0	87	0	87	4	0	6	10	0	95	5	100	0	0	0	0	197
Total	11	396	0	407	35	0	15	50	0	357	34	391	0	0	0	0	848
Grand Total	28	828	0	856	83	0	43	126	0	823	61	884	0	0	0	0	1866
Apprch %	3.3	96.7	0		65.9	0	34.1		0	93.1	6.9		0	0	0		
Total %	1.5	44.4	0	45.9	4.4	0	2.3	6.8	0	44.1	3.3	47.4	0	0	0	0	

Start Time	SR-86 Southbound				Ralph Road Westbound				SR-86 Northbound				Ralph Road Eastbound				Int. Total
	Left	Thru	Right	App. Total	Left	Thru	Right	App. Total	Left	Thru	Right	App. Total	Left	Thru	Right	App. Total	
07:15 AM	4	115	0	119	7	0	8	15	0	116	9	125	0	0	0	0	259
07:30 AM	7	130	0	137	16	0	4	20	0	138	6	144	0	0	0	0	301
07:45 AM	4	122	0	126	20	0	6	26	0	126	7	133	0	0	0	0	285
08:00 AM	4	119	0	123	14	0	4	18	0	91	18	109	0	0	0	0	250
Total Volume	19	486	0	505	57	0	22	79	0	471	40	511	0	0	0	0	1095
% App. Total	3.8	96.2	0		72.2	0	27.8		0	92.2	7.8		0	0	0		
PHF	.679	.935	.000	.922	.713	.000	.688	.760	.000	.853	.556	.887	.000	.000	.000	.000	.909

Peak Hour Analysis From 07:00 AM to 08:45 AM - Peak 1 of 1
 Peak Hour for Entire Intersection Begins at 07:15 AM

City of Imperial
 N/S: SR-86
 E/W: Ralph Road
 Weather: Clear

File Name : 03_IPL_SR-86_Ralph AM
 Site Code : 99921570
 Start Date : 10/13/2021
 Page No : 2

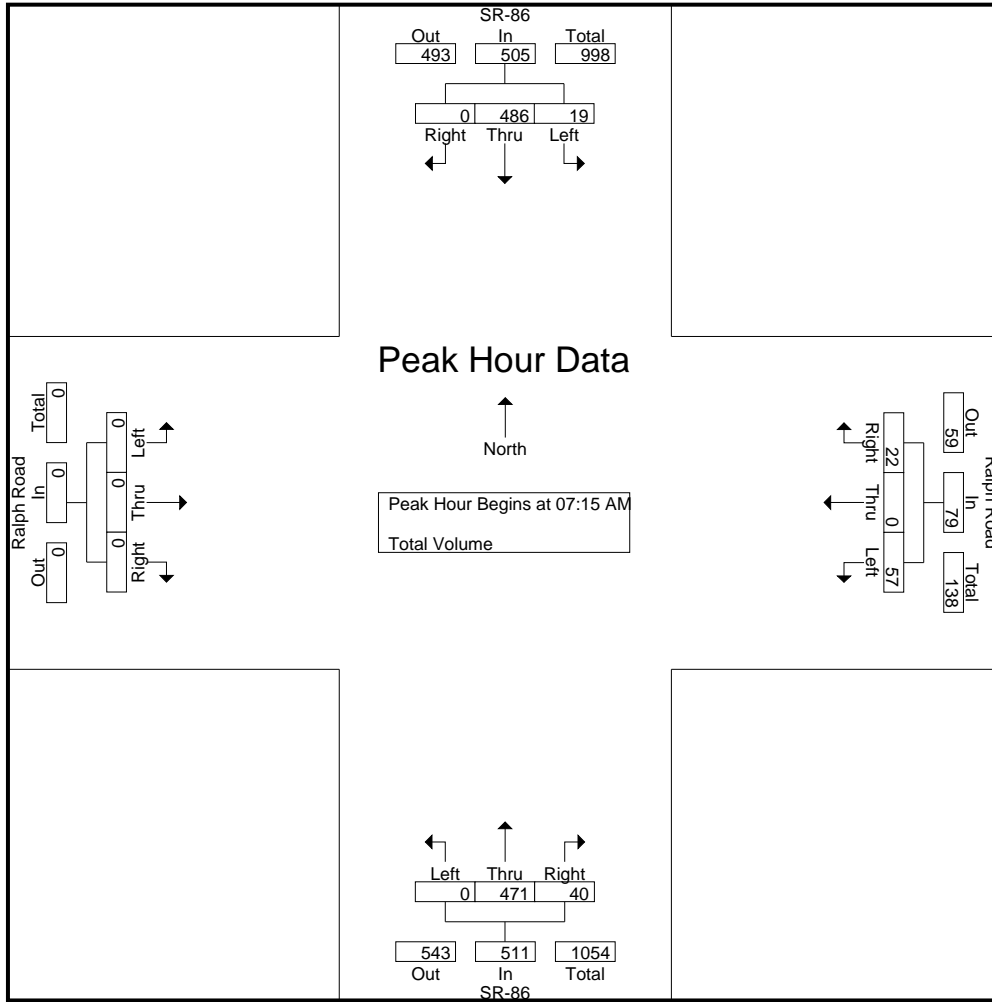

Peak Hour Analysis From 07:00 AM to 08:45 AM - Peak 1 of 1
 Peak Hour for Each Approach Begins at:

	07:15 AM				07:15 AM				07:15 AM				07:00 AM			
+0 mins.	4	115	0	119	7	0	8	15	0	116	9	125	0	0	0	0
+15 mins.	7	130	0	137	16	0	4	20	0	138	6	144	0	0	0	0
+30 mins.	4	122	0	126	20	0	6	26	0	126	7	133	0	0	0	0
+45 mins.	4	119	0	123	14	0	4	18	0	91	18	109	0	0	0	0
Total Volume	19	486	0	505	57	0	22	79	0	471	40	511	0	0	0	0
% App. Total	3.8	96.2	0		72.2	0	27.8		0	92.2	7.8		0	0	0	
PHF	.679	.935	.000	.922	.713	.000	.688	.760	.000	.853	.556	.887	.000	.000	.000	.000

City of Imperial
 N/S: SR-86
 E/W: Ralph Road
 Weather: Clear

File Name : 03_IPL_SR-86_Ralph PM
 Site Code : 99921570
 Start Date : 10/13/2021
 Page No : 1

Groups Printed- Total Volume

Start Time	SR-86 Southbound				Ralph Road Westbound				SR-86 Northbound				Ralph Road Eastbound				Int. Total
	Left	Thru	Right	App. Total	Left	Thru	Right	App. Total	Left	Thru	Right	App. Total	Left	Thru	Right	App. Total	
04:00 PM	5	132	0	137	10	0	2	12	0	106	8	114	0	0	0	0	263
04:15 PM	6	125	0	131	5	0	3	8	1	130	3	134	0	0	0	0	273
04:30 PM	8	116	0	124	10	0	6	16	0	114	8	122	0	0	0	0	262
04:45 PM	9	122	0	131	3	0	2	5	0	117	3	120	0	0	0	0	256
Total	28	495	0	523	28	0	13	41	1	467	22	490	0	0	0	0	1054
05:00 PM	9	137	0	146	3	0	3	6	0	144	7	151	0	0	0	0	303
05:15 PM	6	153	0	159	9	0	0	9	0	138	12	150	0	0	0	0	318
05:30 PM	5	115	0	120	4	0	5	9	0	148	7	155	0	0	0	0	284
05:45 PM	3	92	0	95	6	0	4	10	0	139	5	144	0	0	0	0	249
Total	23	497	0	520	22	0	12	34	0	569	31	600	0	0	0	0	1154
Grand Total	51	992	0	1043	50	0	25	75	1	1036	53	1090	0	0	0	0	2208
Apprch %	4.9	95.1	0		66.7	0	33.3		0.1	95	4.9		0	0	0		
Total %	2.3	44.9	0	47.2	2.3	0	1.1	3.4	0	46.9	2.4	49.4	0	0	0	0	

Start Time	SR-86 Southbound				Ralph Road Westbound				SR-86 Northbound				Ralph Road Eastbound				Int. Total
	Left	Thru	Right	App. Total	Left	Thru	Right	App. Total	Left	Thru	Right	App. Total	Left	Thru	Right	App. Total	
04:45 PM	9	122	0	131	3	0	2	5	0	117	3	120	0	0	0	0	256
05:00 PM	9	137	0	146	3	0	3	6	0	144	7	151	0	0	0	0	303
05:15 PM	6	153	0	159	9	0	0	9	0	138	12	150	0	0	0	0	318
05:30 PM	5	115	0	120	4	0	5	9	0	148	7	155	0	0	0	0	284
Total Volume	29	527	0	556	19	0	10	29	0	547	29	576	0	0	0	0	1161
% App. Total	5.2	94.8	0		65.5	0	34.5		0	95	5		0	0	0		
PHF	.806	.861	.000	.874	.528	.000	.500	.806	.000	.924	.604	.929	.000	.000	.000	.000	.913

Peak Hour Analysis From 04:00 PM to 05:45 PM - Peak 1 of 1
 Peak Hour for Entire Intersection Begins at 04:45 PM

City of Imperial
 N/S: SR-86
 E/W: Ralph Road
 Weather: Clear

File Name : 03_IPL_SR-86_Ralph PM
 Site Code : 99921570
 Start Date : 10/13/2021
 Page No : 2

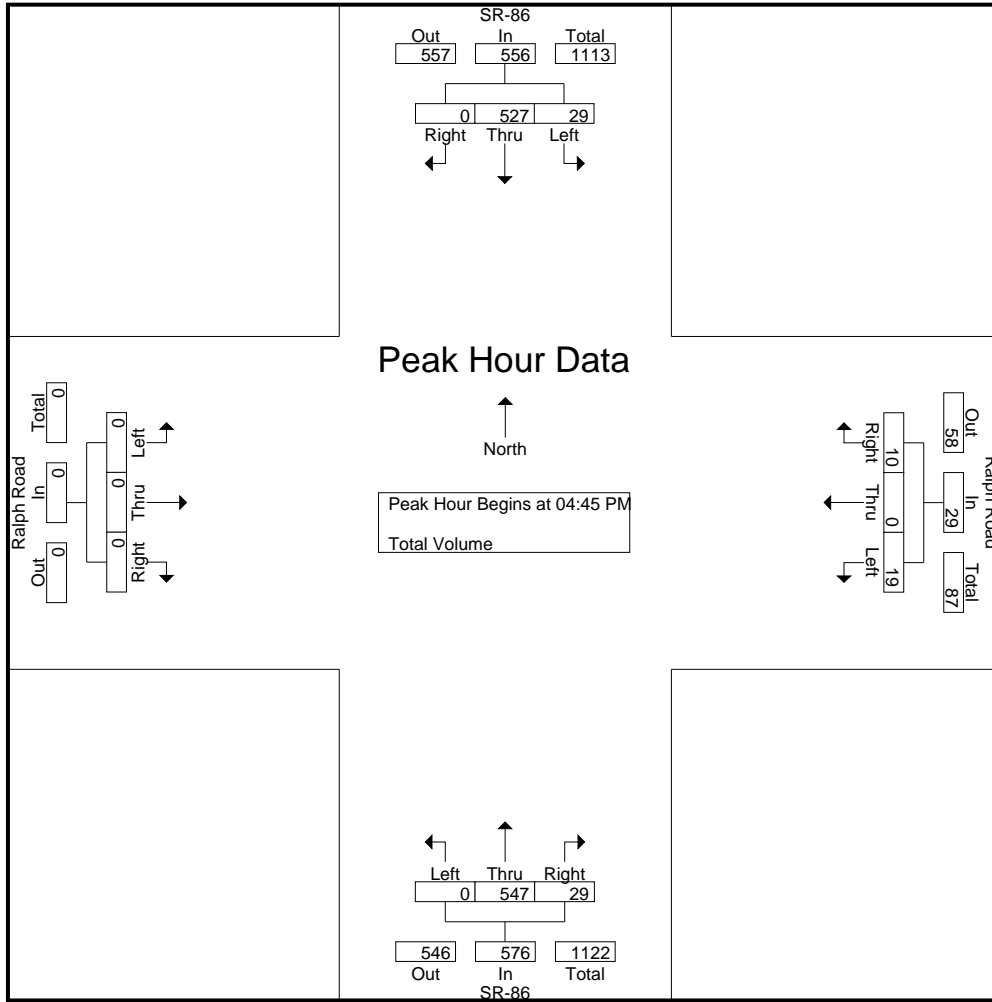

Peak Hour Analysis From 04:00 PM to 05:45 PM - Peak 1 of 1
 Peak Hour for Each Approach Begins at:

	04:30 PM				04:00 PM				05:00 PM				04:00 PM			
+0 mins.	8	116	0	124	10	0	2	12	0	144	7	151	0	0	0	0
+15 mins.	9	122	0	131	5	0	3	8	0	138	12	150	0	0	0	0
+30 mins.	9	137	0	146	10	0	6	16	0	148	7	155	0	0	0	0
+45 mins.	6	153	0	159	3	0	2	5	0	139	5	144	0	0	0	0
Total Volume	32	528	0	560	28	0	13	41	0	569	31	600	0	0	0	0
% App. Total	5.7	94.3	0		68.3	0	31.7		0	94.8	5.2		0	0	0	
PHF	.889	.863	.000	.881	.700	.000	.542	.641	.000	.961	.646	.968	.000	.000	.000	.000

City of Imperial
 N/S: SR-86
 E/W: Neckel Road
 Weather: Clear

File Name : 04_IPL_SR-86_Neckel AM
 Site Code : 99921570
 Start Date : 10/13/2021
 Page No : 1

Groups Printed- Total Volume

Start Time	SR-86 Southbound				Neckel Road Westbound				SR-86 Northbound				Neckel Road Eastbound				Int. Total
	Left	Thru	Right	App. Total	Left	Thru	Right	App. Total	Left	Thru	Right	App. Total	Left	Thru	Right	App. Total	
07:00 AM	2	62	3	67	12	15	17	44	3	80	4	87	9	7	2	18	216
07:15 AM	5	115	5	125	32	14	17	63	3	103	4	110	7	10	2	19	317
07:30 AM	4	123	6	133	43	19	16	78	1	132	8	141	14	9	2	25	377
07:45 AM	4	143	9	156	45	11	8	64	2	106	27	135	8	11	6	25	380
Total	15	443	23	481	132	59	58	249	9	421	43	473	38	37	12	87	1290
08:00 AM	1	116	10	127	18	18	13	49	2	89	24	115	4	12	2	18	309
08:15 AM	3	108	5	116	17	13	12	42	2	81	13	96	5	7	1	13	267
08:30 AM	5	95	2	102	13	6	11	30	1	74	15	90	5	5	3	13	235
08:45 AM	4	101	0	105	9	4	6	19	2	90	4	96	1	1	1	3	223
Total	13	420	17	450	57	41	42	140	7	334	56	397	15	25	7	47	1034
Grand Total	28	863	40	931	189	100	100	389	16	755	99	870	53	62	19	134	2324
Apprch %	3	92.7	4.3		48.6	25.7	25.7		1.8	86.8	11.4		39.6	46.3	14.2		
Total %	1.2	37.1	1.7	40.1	8.1	4.3	4.3	16.7	0.7	32.5	4.3	37.4	2.3	2.7	0.8	5.8	

Start Time	SR-86 Southbound				Neckel Road Westbound				SR-86 Northbound				Neckel Road Eastbound				Int. Total
	Left	Thru	Right	App. Total	Left	Thru	Right	App. Total	Left	Thru	Right	App. Total	Left	Thru	Right	App. Total	
Peak Hour Analysis From 07:00 AM to 08:45 AM - Peak 1 of 1																	
Peak Hour for Entire Intersection Begins at 07:15 AM																	
07:15 AM	5	115	5	125	32	14	17	63	3	103	4	110	7	10	2	19	317
07:30 AM	4	123	6	133	43	19	16	78	1	132	8	141	14	9	2	25	377
07:45 AM	4	143	9	156	45	11	8	64	2	106	27	135	8	11	6	25	380
08:00 AM	1	116	10	127	18	18	13	49	2	89	24	115	4	12	2	18	309
Total Volume	14	497	30	541	138	62	54	254	8	430	63	501	33	42	12	87	1383
% App. Total	2.6	91.9	5.5		54.3	24.4	21.3		1.6	85.8	12.6		37.9	48.3	13.8		
PHF	.700	.869	.750	.867	.767	.816	.794	.814	.667	.814	.583	.888	.589	.875	.500	.870	.910

City of Imperial
 N/S: SR-86
 E/W: Neckel Road
 Weather: Clear

File Name : 04_IPL_SR-86_Neckel AM
 Site Code : 99921570
 Start Date : 10/13/2021
 Page No : 2

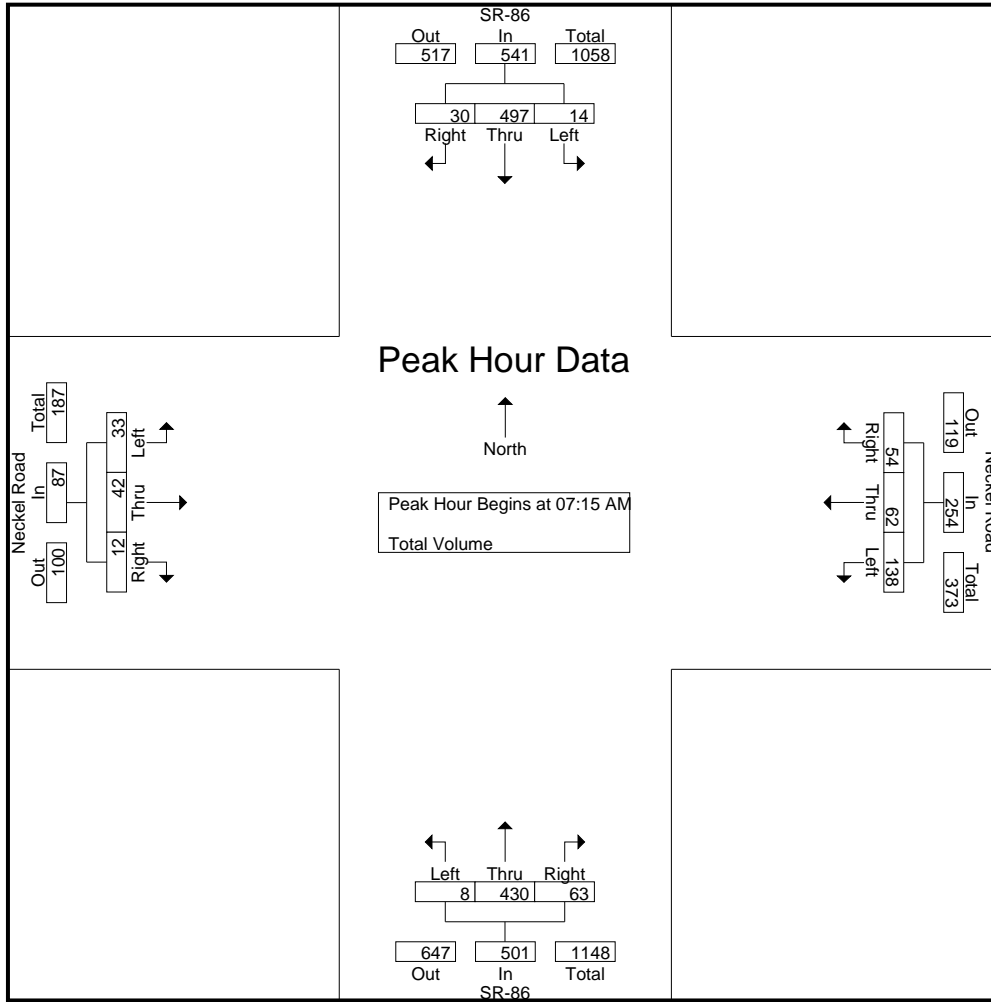

Peak Hour Analysis From 07:00 AM to 08:45 AM - Peak 1 of 1
 Peak Hour for Each Approach Begins at:

	07:15 AM				07:15 AM				07:15 AM				07:00 AM			
+0 mins.	5	115	5	125	32	14	17	63	3	103	4	110	9	7	2	18
+15 mins.	4	123	6	133	43	19	16	78	1	132	8	141	7	10	2	19
+30 mins.	4	143	9	156	45	11	8	64	2	106	27	135	14	9	2	25
+45 mins.	1	116	10	127	18	18	13	49	2	89	24	115	8	11	6	25
Total Volume	14	497	30	541	138	62	54	254	8	430	63	501	38	37	12	87
% App. Total	2.6	91.9	5.5		54.3	24.4	21.3		1.6	85.8	12.6		43.7	42.5	13.8	
PHF	.700	.869	.750	.867	.767	.816	.794	.814	.667	.814	.583	.888	.679	.841	.500	.870

City of Imperial
 N/S: SR-86
 E/W: Neckel Road
 Weather: Clear

File Name : 04_IPL_SR-86_Neckel PM
 Site Code : 99921570
 Start Date : 10/13/2021
 Page No : 1

Groups Printed- Total Volume

Start Time	SR-86 Southbound				Neckel Road Westbound				SR-86 Northbound				Neckel Road Eastbound				Int. Total
	Left	Thru	Right	App. Total	Left	Thru	Right	App. Total	Left	Thru	Right	App. Total	Left	Thru	Right	App. Total	
04:00 PM	7	131	8	146	23	8	16	47	4	109	20	133	0	11	3	14	340
04:15 PM	10	121	8	139	12	6	10	28	3	128	21	152	3	5	2	10	329
04:30 PM	7	114	11	132	8	4	10	22	5	113	18	136	0	12	3	15	305
04:45 PM	6	116	9	131	12	8	8	28	2	120	20	142	3	8	0	11	312
Total	30	482	36	548	55	26	44	125	14	470	79	563	6	36	8	50	1286
05:00 PM	9	130	5	144	19	5	7	31	4	132	12	148	2	5	0	7	330
05:15 PM	6	145	10	161	19	4	12	35	2	134	19	155	5	11	3	19	370
05:30 PM	8	106	9	123	16	5	15	36	3	140	29	172	3	4	0	7	338
05:45 PM	5	101	3	109	26	5	11	42	2	134	21	157	2	5	1	8	316
Total	28	482	27	537	80	19	45	144	11	540	81	632	12	25	4	41	1354
Grand Total	58	964	63	1085	135	45	89	269	25	1010	160	1195	18	61	12	91	2640
Apprch %	5.3	88.8	5.8		50.2	16.7	33.1		2.1	84.5	13.4		19.8	67	13.2		
Total %	2.2	36.5	2.4	41.1	5.1	1.7	3.4	10.2	0.9	38.3	6.1	45.3	0.7	2.3	0.5	3.4	

Start Time	SR-86 Southbound				Neckel Road Westbound				SR-86 Northbound				Neckel Road Eastbound				Int. Total
	Left	Thru	Right	App. Total	Left	Thru	Right	App. Total	Left	Thru	Right	App. Total	Left	Thru	Right	App. Total	
05:00 PM	9	130	5	144	19	5	7	31	4	132	12	148	2	5	0	7	330
05:15 PM	6	145	10	161	19	4	12	35	2	134	19	155	5	11	3	19	370
05:30 PM	8	106	9	123	16	5	15	36	3	140	29	172	3	4	0	7	338
05:45 PM	5	101	3	109	26	5	11	42	2	134	21	157	2	5	1	8	316
Total Volume	28	482	27	537	80	19	45	144	11	540	81	632	12	25	4	41	1354
% App. Total	5.2	89.8	5		55.6	13.2	31.2		1.7	85.4	12.8		29.3	61	9.8		
PHF	.778	.831	.675	.834	.769	.950	.750	.857	.688	.964	.698	.919	.600	.568	.333	.539	.915

Peak Hour Analysis From 04:00 PM to 05:45 PM - Peak 1 of 1
 Peak Hour for Entire Intersection Begins at 05:00 PM

City of Imperial
 N/S: SR-86
 E/W: Neckel Road
 Weather: Clear

File Name : 04_IPL_SR-86_Neckel PM
 Site Code : 99921570
 Start Date : 10/13/2021
 Page No : 2

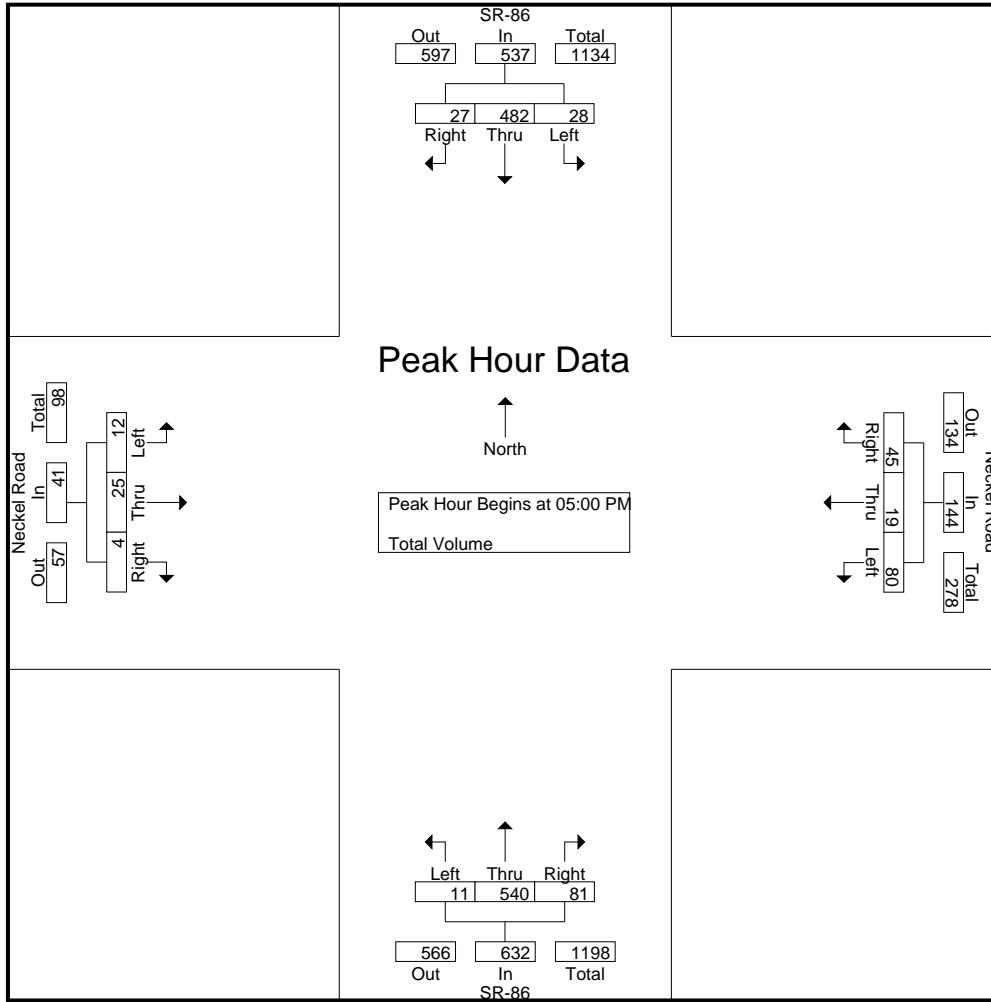

Peak Hour Analysis From 04:00 PM to 05:45 PM - Peak 1 of 1
 Peak Hour for Each Approach Begins at:

	04:30 PM				05:00 PM				05:00 PM				04:30 PM			
+0 mins.	7	114	11	132	19	5	7	31	4	132	12	148	0	12	3	15
+15 mins.	6	116	9	131	19	4	12	35	2	134	19	155	3	8	0	11
+30 mins.	9	130	5	144	16	5	15	36	3	140	29	172	2	5	0	7
+45 mins.	6	145	10	161	26	5	11	42	2	134	21	157	5	11	3	19
Total Volume	28	505	35	568	80	19	45	144	11	540	81	632	10	36	6	52
% App. Total	4.9	88.9	6.2		55.6	13.2	31.2		1.7	85.4	12.8		19.2	69.2	11.5	
PHF	.778	.871	.795	.882	.769	.950	.750	.857	.688	.964	.698	.919	.500	.750	.500	.684

City of Imperial
 N/S: La Brucherie Road
 E/W: Neckel Road
 Weather: Clear

File Name : 05_IPL_La B_Neckel AM
 Site Code : 99921570
 Start Date : 10/13/2021
 Page No : 1

Groups Printed- Total Volume

Start Time	La Brucherie Road Southbound				Neckel Road Westbound				La Brucherie Road Northbound				Neckel Road Eastbound				Int. Total
	Left	Thru	Right	App. Total	Left	Thru	Right	App. Total	Left	Thru	Right	App. Total	Left	Thru	Right	App. Total	
07:00 AM	0	0	0	0	3	15	0	18	1	3	7	11	1	9	0	10	39
07:15 AM	0	0	1	1	6	14	1	21	0	1	7	8	0	13	1	14	44
07:30 AM	0	1	0	1	16	14	0	30	2	0	9	11	2	16	11	29	71
07:45 AM	0	0	0	0	14	6	0	20	1	2	16	19	1	9	8	18	57
Total	0	1	1	2	39	49	1	89	4	6	39	49	4	47	20	71	211
08:00 AM	0	0	1	1	12	14	0	26	3	0	9	12	1	8	1	10	49
08:15 AM	1	1	0	2	16	9	0	25	1	4	7	12	0	7	2	9	48
08:30 AM	0	1	0	1	1	7	0	8	0	1	3	4	1	6	3	10	23
08:45 AM	0	0	0	0	1	2	2	5	1	1	1	3	1	3	3	7	15
Total	1	2	1	4	30	32	2	64	5	6	20	31	3	24	9	36	135
Grand Total	1	3	2	6	69	81	3	153	9	12	59	80	7	71	29	107	346
Apprch %	16.7	50	33.3		45.1	52.9	2		11.2	15	73.8		6.5	66.4	27.1		
Total %	0.3	0.9	0.6	1.7	19.9	23.4	0.9	44.2	2.6	3.5	17.1	23.1	2	20.5	8.4	30.9	

Start Time	La Brucherie Road Southbound				Neckel Road Westbound				La Brucherie Road Northbound				Neckel Road Eastbound				Int. Total
	Left	Thru	Right	App. Total	Left	Thru	Right	App. Total	Left	Thru	Right	App. Total	Left	Thru	Right	App. Total	
Peak Hour Analysis From 07:00 AM to 08:45 AM - Peak 1 of 1																	
Peak Hour for Entire Intersection Begins at 07:30 AM																	
07:30 AM	0	1	0	1	16	14	0	30	2	0	9	11	2	16	11	29	71
07:45 AM	0	0	0	0	14	6	0	20	1	2	16	19	1	9	8	18	57
08:00 AM	0	0	1	1	12	14	0	26	3	0	9	12	1	8	1	10	49
08:15 AM	1	1	0	2	16	9	0	25	1	4	7	12	0	7	2	9	48
Total Volume	1	2	1	4	58	43	0	101	7	6	41	54	4	40	22	66	225
% App. Total	25	50	25		57.4	42.6	0		13	11.1	75.9		6.1	60.6	33.3		
PHF	.250	.500	.250	.500	.906	.768	.000	.842	.583	.375	.641	.711	.500	.625	.500	.569	.792

City of Imperial
 N/S: La Brucherie Road
 E/W: Neckel Road
 Weather: Clear

File Name : 05_IPL_La B_Neckel AM
 Site Code : 99921570
 Start Date : 10/13/2021
 Page No : 2

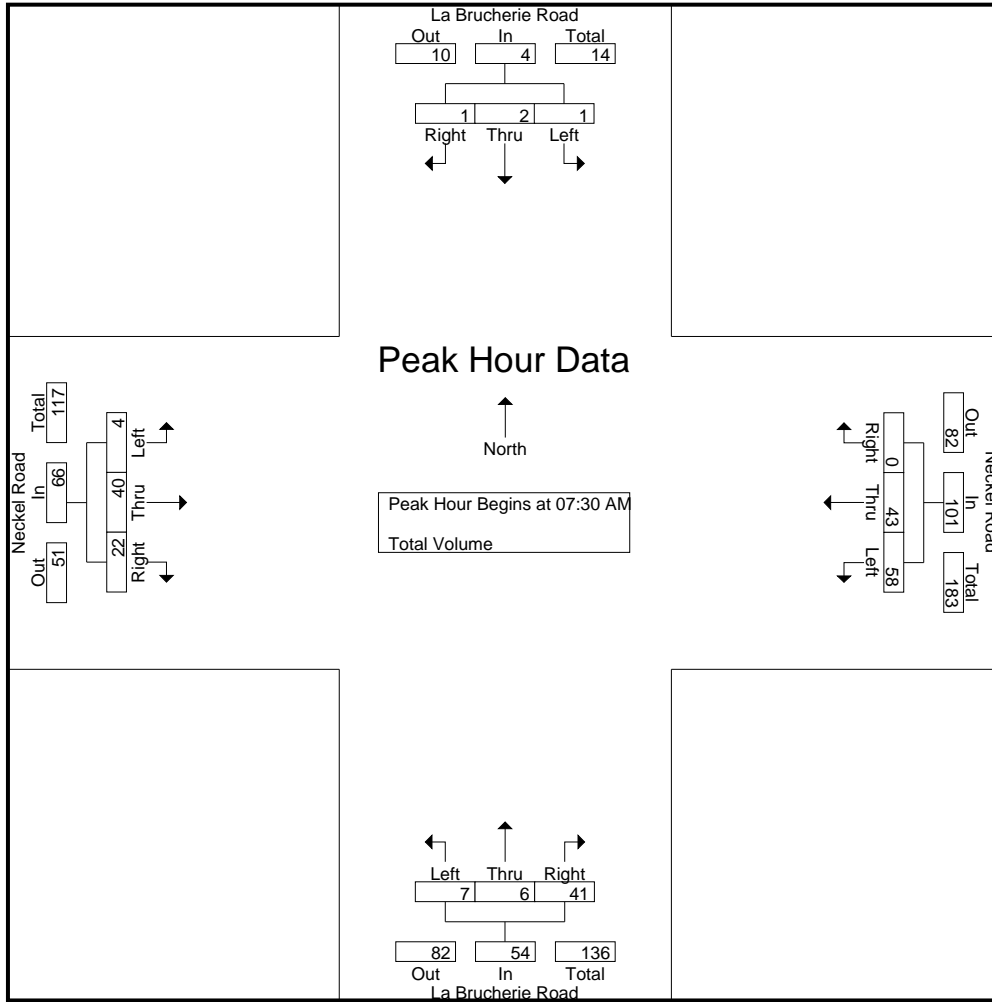

Peak Hour Analysis From 07:00 AM to 08:45 AM - Peak 1 of 1
 Peak Hour for Each Approach Begins at:

	07:30 AM				07:30 AM				07:30 AM				07:00 AM			
+0 mins.	0	1	0	1	16	14	0	30	2	0	9	11	1	9	0	10
+15 mins.	0	0	0	0	14	6	0	20	1	2	16	19	0	13	1	14
+30 mins.	0	0	1	1	12	14	0	26	3	0	9	12	2	16	11	29
+45 mins.	1	1	0	2	16	9	0	25	1	4	7	12	1	9	8	18
Total Volume	1	2	1	4	58	43	0	101	7	6	41	54	4	47	20	71
% App. Total	25	50	25		57.4	42.6	0		13	11.1	75.9		5.6	66.2	28.2	
PHF	.250	.500	.250	.500	.906	.768	.000	.842	.583	.375	.641	.711	.500	.734	.455	.612

City of Imperial
 N/S: La Brucherie Road
 E/W: Neckel Road
 Weather: Clear

File Name : 05_IPL_La B_Neckel PM
 Site Code : 99921570
 Start Date : 10/13/2021
 Page No : 1

Groups Printed- Total Volume

Start Time	La Brucherie Road Southbound				Neckel Road Westbound				La Brucherie Road Northbound				Neckel Road Eastbound				Int. Total
	Left	Thru	Right	App. Total	Left	Thru	Right	App. Total	Left	Thru	Right	App. Total	Left	Thru	Right	App. Total	
04:00 PM	0	0	2	2	9	8	0	17	1	0	1	2	1	13	3	17	38
04:15 PM	0	0	2	2	2	11	0	13	1	1	3	5	1	6	2	9	29
04:30 PM	0	1	1	2	6	14	1	21	3	3	3	9	0	13	1	14	46
04:45 PM	0	4	2	6	5	10	0	15	0	2	3	5	0	5	2	7	33
Total	0	5	7	12	22	43	1	66	5	6	10	21	2	37	8	47	146
05:00 PM	0	2	0	2	3	11	0	14	1	1	3	5	0	5	0	5	26
05:15 PM	0	2	0	2	4	10	0	14	2	4	4	10	0	11	2	13	39
05:30 PM	0	4	0	4	4	11	0	15	1	1	2	4	1	5	2	8	31
05:45 PM	1	0	2	3	4	7	0	11	1	1	1	3	0	6	2	8	25
Total	1	8	2	11	15	39	0	54	5	7	10	22	1	27	6	34	121
Grand Total	1	13	9	23	37	82	1	120	10	13	20	43	3	64	14	81	267
Apprch %	4.3	56.5	39.1		30.8	68.3	0.8		23.3	30.2	46.5		3.7	79	17.3		
Total %	0.4	4.9	3.4	8.6	13.9	30.7	0.4	44.9	3.7	4.9	7.5	16.1	1.1	24	5.2	30.3	

Start Time	La Brucherie Road Southbound				Neckel Road Westbound				La Brucherie Road Northbound				Neckel Road Eastbound				Int. Total
	Left	Thru	Right	App. Total	Left	Thru	Right	App. Total	Left	Thru	Right	App. Total	Left	Thru	Right	App. Total	
04:00 PM	0	0	2	2	9	8	0	17	1	0	1	2	1	13	3	17	38
04:15 PM	0	0	2	2	2	11	0	13	1	1	3	5	1	6	2	9	29
04:30 PM	0	1	1	2	6	14	1	21	3	3	3	9	0	13	1	14	46
04:45 PM	0	4	2	6	5	10	0	15	0	2	3	5	0	5	2	7	33
Total Volume	0	5	7	12	22	43	1	66	5	6	10	21	2	37	8	47	146
% App. Total	0	41.7	58.3		33.3	65.2	1.5		23.8	28.6	47.6		4.3	78.7	17		
PHF	.000	.313	.875	.500	.611	.768	.250	.786	.417	.500	.833	.583	.500	.712	.667	.691	.793

Peak Hour Analysis From 04:00 PM to 05:45 PM - Peak 1 of 1
 Peak Hour for Entire Intersection Begins at 04:00 PM

City of Imperial
 N/S: La Brucherie Road
 E/W: Neckel Road
 Weather: Clear

File Name : 05_IPL_La B_Neckel PM
 Site Code : 99921570
 Start Date : 10/13/2021
 Page No : 2

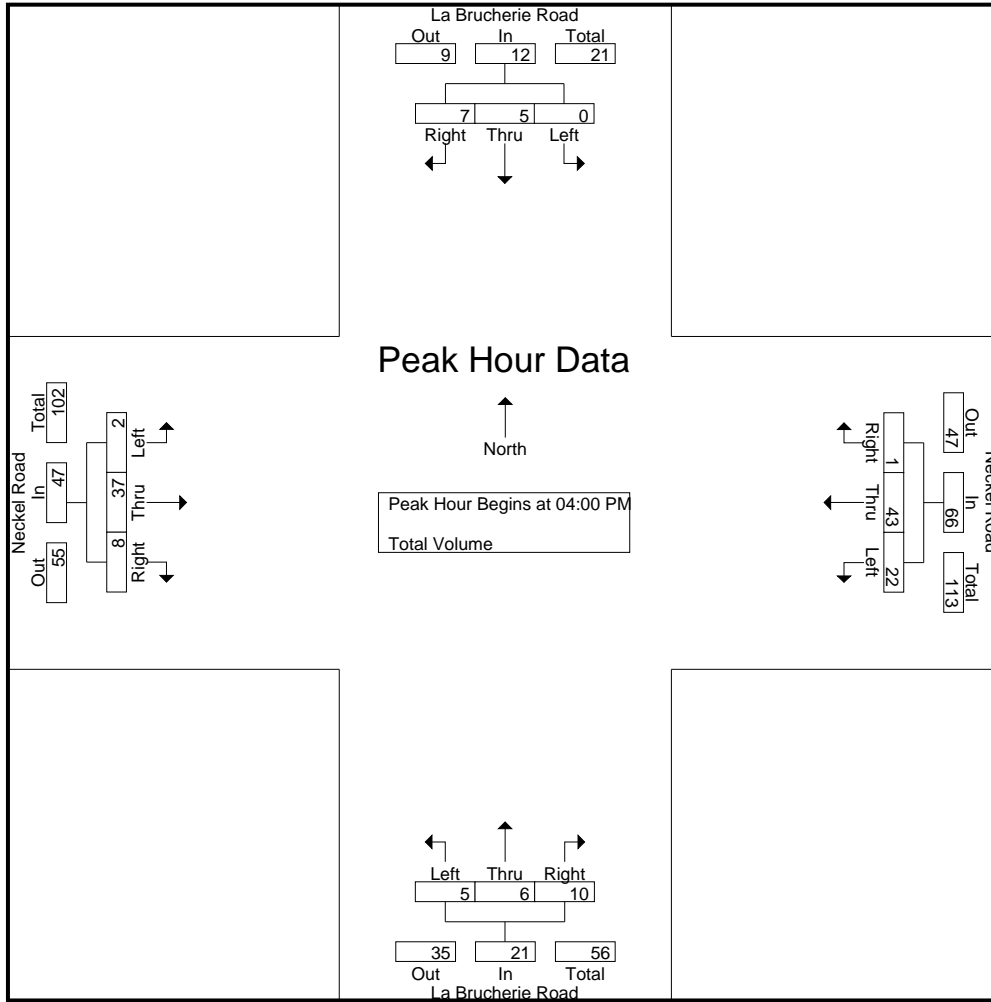

Peak Hour Analysis From 04:00 PM to 05:45 PM - Peak 1 of 1
 Peak Hour for Each Approach Begins at:

	04:45 PM				04:00 PM				04:30 PM				04:00 PM			
+0 mins.	0	4	2	6	9	8	0	17	3	3	3	9	1	13	3	17
+15 mins.	0	2	0	2	2	11	0	13	0	2	3	5	1	6	2	9
+30 mins.	0	2	0	2	6	14	1	21	1	1	3	5	0	13	1	14
+45 mins.	0	4	0	4	5	10	0	15	2	4	4	10	0	5	2	7
Total Volume	0	12	2	14	22	43	1	66	6	10	13	29	2	37	8	47
% App. Total	0	85.7	14.3		33.3	65.2	1.5		20.7	34.5	44.8		4.3	78.7	17	
PHF	.000	.750	.250	.583	.611	.768	.250	.786	.500	.625	.813	.725	.500	.712	.667	.691

City of Imperial
 N/S: SR-86
 E/W: Worthington Road/Barioni Boulevard
 Weather: Clear

File Name : 06_IPL_SR-86_Worthington AM
 Site Code : 99921570
 Start Date : 10/13/2021
 Page No : 1

Groups Printed- Total Volume

Start Time	SR-86 Southbound				Barioni Boulevard Westbound				SR-86 Northbound				Worthington Road Eastbound				Int. Total
	Left	Thru	Right	App. Total	Left	Thru	Right	App. Total	Left	Thru	Right	App. Total	Left	Thru	Right	App. Total	
07:00 AM	5	75	13	93	4	12	8	24	8	77	9	94	9	27	21	57	268
07:15 AM	6	130	11	147	8	17	20	45	13	95	18	126	10	22	34	66	384
07:30 AM	13	182	13	208	22	30	15	67	20	136	17	173	17	39	46	102	550
07:45 AM	8	162	8	178	8	33	25	66	22	140	13	175	21	30	59	110	529
Total	32	549	45	626	42	92	68	202	63	448	57	568	57	118	160	335	1731
08:00 AM	9	141	18	168	16	47	12	75	29	86	11	126	19	29	59	107	476
08:15 AM	8	128	15	151	7	18	23	48	19	90	8	117	11	34	42	87	403
08:30 AM	7	125	9	141	6	12	9	27	13	95	9	117	6	20	34	60	345
08:45 AM	5	122	7	134	7	16	7	30	8	89	5	102	5	14	19	38	304
Total	29	516	49	594	36	93	51	180	69	360	33	462	41	97	154	292	1528
Grand Total	61	1065	94	1220	78	185	119	382	132	808	90	1030	98	215	314	627	3259
Apprch %	5	87.3	7.7		20.4	48.4	31.2		12.8	78.4	8.7		15.6	34.3	50.1		
Total %	1.9	32.7	2.9	37.4	2.4	5.7	3.7	11.7	4.1	24.8	2.8	31.6	3	6.6	9.6	19.2	

Start Time	SR-86 Southbound				Barioni Boulevard Westbound				SR-86 Northbound				Worthington Road Eastbound				Int. Total
	Left	Thru	Right	App. Total	Left	Thru	Right	App. Total	Left	Thru	Right	App. Total	Left	Thru	Right	App. Total	
Peak Hour Analysis From 07:00 AM to 08:45 AM - Peak 1 of 1																	
Peak Hour for Entire Intersection Begins at 07:30 AM																	
07:30 AM	13	182	13	208	22	30	15	67	20	136	17	173	17	39	46	102	550
07:45 AM	8	162	8	178	8	33	25	66	22	140	13	175	21	30	59	110	529
08:00 AM	9	141	18	168	16	47	12	75	29	86	11	126	19	29	59	107	476
08:15 AM	8	128	15	151	7	18	23	48	19	90	8	117	11	34	42	87	403
Total Volume	38	613	54	705	53	128	75	256	90	452	49	591	68	132	206	406	1958
% App. Total	5.4	87	7.7		20.7	50	29.3		15.2	76.5	8.3		16.7	32.5	50.7		
PHF	.731	.842	.750	.847	.602	.681	.750	.853	.776	.807	.721	.844	.810	.846	.873	.923	.890

City of Imperial
 N/S: SR-86
 E/W: Worthington Road/Barioni Boulevard
 Weather: Clear

File Name : 06_IPL_SR-86_Worthington AM
 Site Code : 99921570
 Start Date : 10/13/2021
 Page No : 2

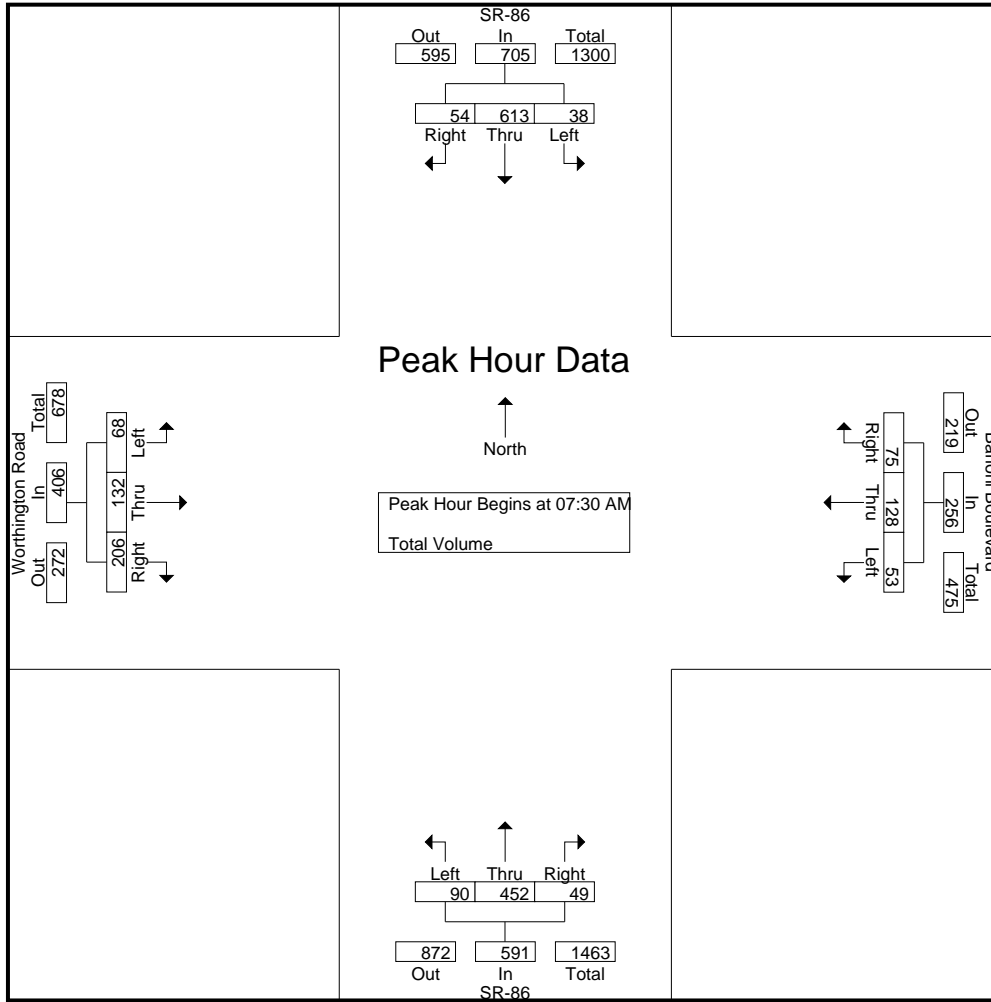

Peak Hour Analysis From 07:00 AM to 08:45 AM - Peak 1 of 1
 Peak Hour for Each Approach Begins at:

	07:30 AM				07:30 AM				07:15 AM				07:30 AM			
+0 mins.	13	182	13	208	22	30	15	67	13	95	18	126	17	39	46	102
+15 mins.	8	162	8	178	8	33	25	66	20	136	17	173	21	30	59	110
+30 mins.	9	141	18	168	16	47	12	75	22	140	13	175	19	29	59	107
+45 mins.	8	128	15	151	7	18	23	48	29	86	11	126	11	34	42	87
Total Volume	38	613	54	705	53	128	75	256	84	457	59	600	68	132	206	406
% App. Total	5.4	87	7.7		20.7	50	29.3		14	76.2	9.8		16.7	32.5	50.7	
PHF	.731	.842	.750	.847	.602	.681	.750	.853	.724	.816	.819	.857	.810	.846	.873	.923

City of Imperial
 N/S: SR-86
 E/W: Worthington Road/Barioni Boulevard
 Weather: Clear

File Name : 06_IPL_SR-86_Worthington PM
 Site Code : 99921570
 Start Date : 10/13/2021
 Page No : 1

Groups Printed- Total Volume

Start Time	SR-86 Southbound				Barioni Boulevard Westbound				SR-86 Northbound				Worthington Road Eastbound				Int. Total
	Left	Thru	Right	App. Total	Left	Thru	Right	App. Total	Left	Thru	Right	App. Total	Left	Thru	Right	App. Total	
04:00 PM	10	146	6	162	9	34	17	60	20	145	5	170	9	18	27	54	446
04:15 PM	4	124	9	137	10	30	13	53	17	155	4	176	8	21	31	60	426
04:30 PM	4	136	8	148	17	33	5	55	17	135	7	159	9	19	22	50	412
04:45 PM	10	118	11	139	4	31	7	42	29	147	2	178	9	21	29	59	418
Total	28	524	34	586	40	128	42	210	83	582	18	683	35	79	109	223	1702
05:00 PM	4	149	8	161	8	34	8	50	20	167	8	195	13	19	28	60	466
05:15 PM	6	186	25	217	15	27	19	61	31	163	2	196	7	18	17	42	516
05:30 PM	10	122	12	144	19	28	8	55	32	158	1	191	11	17	31	59	449
05:45 PM	6	120	16	142	11	20	15	46	26	160	3	189	16	18	26	60	437
Total	26	577	61	664	53	109	50	212	109	648	14	771	47	72	102	221	1868
Grand Total	54	1101	95	1250	93	237	92	422	192	1230	32	1454	82	151	211	444	3570
Apprch %	4.3	88.1	7.6		22	56.2	21.8		13.2	84.6	2.2		18.5	34	47.5		
Total %	1.5	30.8	2.7	35	2.6	6.6	2.6	11.8	5.4	34.5	0.9	40.7	2.3	4.2	5.9	12.4	

Start Time	SR-86 Southbound				Barioni Boulevard Westbound				SR-86 Northbound				Worthington Road Eastbound				Int. Total
	Left	Thru	Right	App. Total	Left	Thru	Right	App. Total	Left	Thru	Right	App. Total	Left	Thru	Right	App. Total	
05:00 PM	4	149	8	161	8	34	8	50	20	167	8	195	13	19	28	60	466
05:15 PM	6	186	25	217	15	27	19	61	31	163	2	196	7	18	17	42	516
05:30 PM	10	122	12	144	19	28	8	55	32	158	1	191	11	17	31	59	449
05:45 PM	6	120	16	142	11	20	15	46	26	160	3	189	16	18	26	60	437
Total Volume	26	577	61	664	53	109	50	212	109	648	14	771	47	72	102	221	1868
% App. Total	3.9	86.9	9.2		25	51.4	23.6		14.1	84	1.8		21.3	32.6	46.2		
PHF	.650	.776	.610	.765	.697	.801	.658	.869	.852	.970	.438	.983	.734	.947	.823	.921	.905

Peak Hour Analysis From 04:00 PM to 05:45 PM - Peak 1 of 1
 Peak Hour for Entire Intersection Begins at 05:00 PM

City of Imperial
 N/S: SR-86
 E/W: Worthington Road/Barioni Boulevard
 Weather: Clear

File Name : 06_IPL_SR-86_Worthington PM
 Site Code : 99921570
 Start Date : 10/13/2021
 Page No : 2

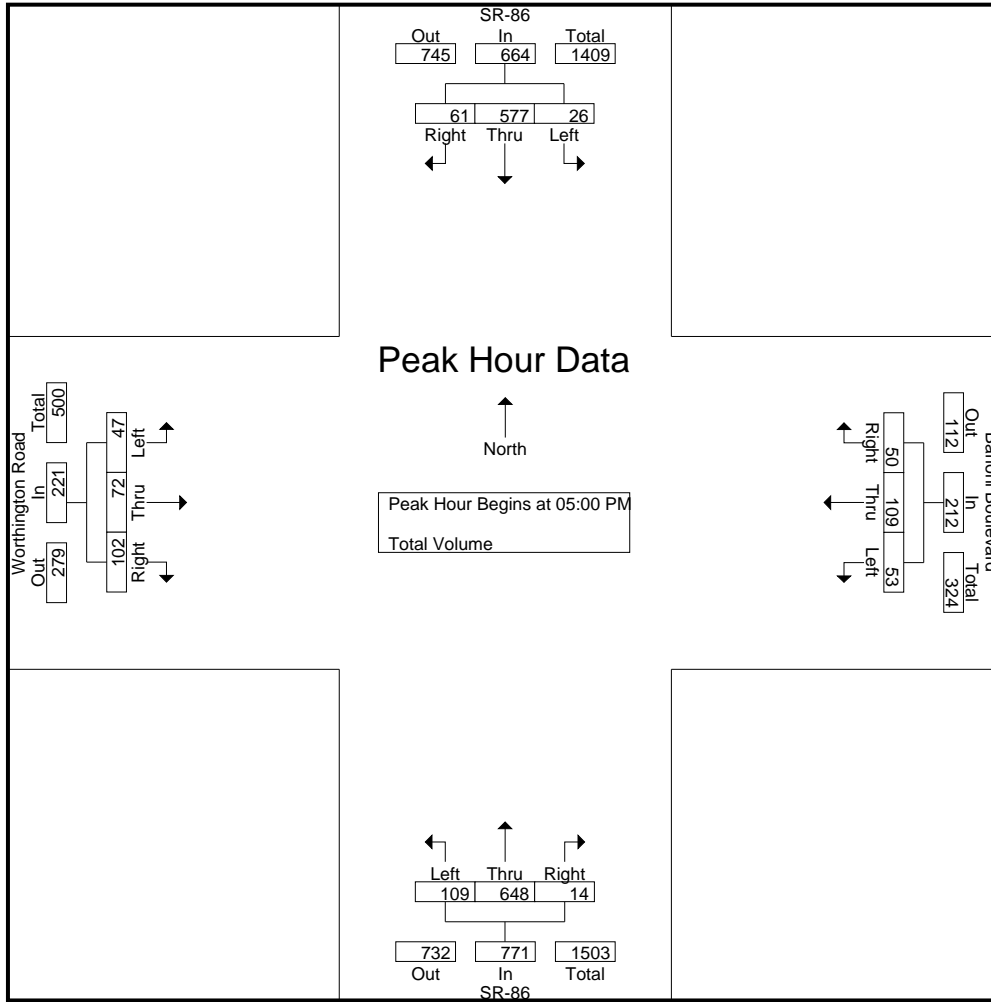

Peak Hour Analysis From 04:00 PM to 05:45 PM - Peak 1 of 1
 Peak Hour for Each Approach Begins at:

	04:30 PM				05:00 PM				05:00 PM				04:15 PM			
+0 mins.	4	136	8	148	8	34	8	50	20	167	8	195	8	21	31	60
+15 mins.	10	118	11	139	15	27	19	61	31	163	2	196	9	19	22	50
+30 mins.	4	149	8	161	19	28	8	55	32	158	1	191	9	21	29	59
+45 mins.	6	186	25	217	11	20	15	46	26	160	3	189	13	19	28	60
Total Volume	24	589	52	665	53	109	50	212	109	648	14	771	39	80	110	229
% App. Total	3.6	88.6	7.8		25	51.4	23.6		14.1	84	1.8		17	34.9	48	
PHF	.600	.792	.520	.766	.697	.801	.658	.869	.852	.970	.438	.983	.750	.952	.887	.954

City of Imperial
 N/S: La Brucherie Road/B Street
 E/W: Worthington Road
 Weather: Clear

File Name : 07_IPL_La B_Worthington AM
 Site Code : 99921570
 Start Date : 10/13/2021
 Page No : 1

Groups Printed- Total Volume

Start Time	La Brucherie Road Southbound				Worthington Road Westbound				B Street Northbound				Worthington Road Eastbound				Int. Total
	Left	Thru	Right	App. Total	Left	Thru	Right	App. Total	Left	Thru	Right	App. Total	Left	Thru	Right	App. Total	
07:00 AM	10	1	4	15	0	33	7	40	0	0	0	0	6	52	3	61	116
07:15 AM	12	4	5	21	2	31	5	38	0	0	0	0	9	59	9	77	136
07:30 AM	29	10	11	50	1	50	18	69	0	0	0	0	20	99	45	164	283
07:45 AM	29	16	15	60	2	89	26	117	0	0	1	1	13	99	52	164	342
Total	80	31	35	146	5	203	56	264	0	0	1	1	48	309	109	466	877
08:00 AM	13	3	16	32	4	86	16	106	0	0	0	0	13	85	18	116	254
08:15 AM	32	1	20	53	4	68	15	87	0	0	0	0	13	96	1	110	250
08:30 AM	3	0	4	7	1	25	2	28	0	0	0	0	5	30	0	35	70
08:45 AM	5	0	7	12	0	26	7	33	0	0	0	0	1	32	0	33	78
Total	53	4	47	104	9	205	40	254	0	0	0	0	32	243	19	294	652
Grand Total	133	35	82	250	14	408	96	518	0	0	1	1	80	552	128	760	1529
Apprch %	53.2	14	32.8		2.7	78.8	18.5		0	0	100		10.5	72.6	16.8		
Total %	8.7	2.3	5.4	16.4	0.9	26.7	6.3	33.9	0	0	0.1	0.1	5.2	36.1	8.4	49.7	

Start Time	La Brucherie Road Southbound				Worthington Road Westbound				B Street Northbound				Worthington Road Eastbound				Int. Total
	Left	Thru	Right	App. Total	Left	Thru	Right	App. Total	Left	Thru	Right	App. Total	Left	Thru	Right	App. Total	
07:30 AM	29	10	11	50	1	50	18	69	0	0	0	0	20	99	45	164	283
07:45 AM	29	16	15	60	2	89	26	117	0	0	1	1	13	99	52	164	342
08:00 AM	13	3	16	32	4	86	16	106	0	0	0	0	13	85	18	116	254
08:15 AM	32	1	20	53	4	68	15	87	0	0	0	0	13	96	1	110	250
Total Volume	103	30	62	195	11	293	75	379	0	0	1	1	59	379	116	554	1129
% App. Total	52.8	15.4	31.8		2.9	77.3	19.8		0	0	100		10.6	68.4	20.9		
PHF	.805	.469	.775	.813	.688	.823	.721	.810	.000	.000	.250	.250	.738	.957	.558	.845	.825

Peak Hour Analysis From 07:00 AM to 08:45 AM - Peak 1 of 1
 Peak Hour for Entire Intersection Begins at 07:30 AM

City of Imperial
 N/S: La Brucherie Road/B Street
 E/W: Worthington Road
 Weather: Clear

File Name : 07_IPL_La B_Worthington AM
 Site Code : 99921570
 Start Date : 10/13/2021
 Page No : 2

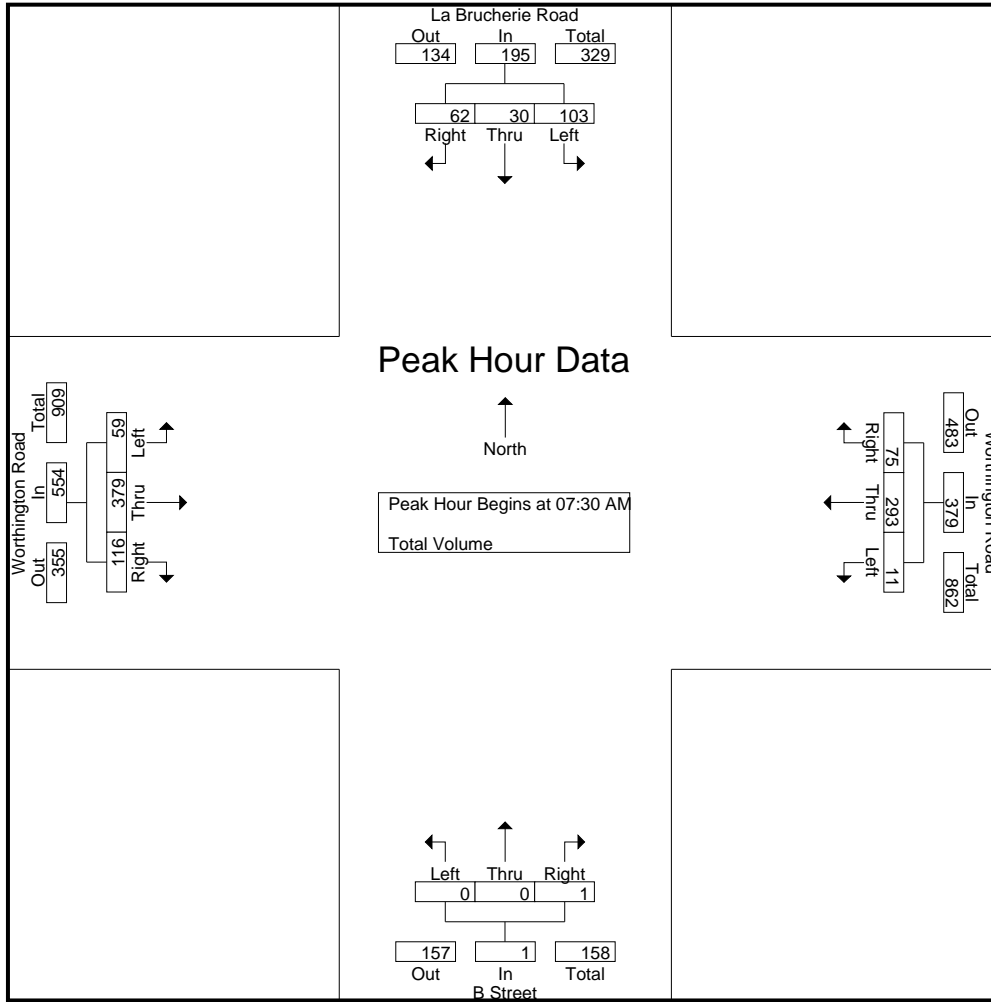

Peak Hour Analysis From 07:00 AM to 08:45 AM - Peak 1 of 1
 Peak Hour for Each Approach Begins at:

	07:30 AM				07:30 AM				07:00 AM				07:30 AM			
+0 mins.	29	10	11	50	1	50	18	69	0	0	0	0	20	99	45	164
+15 mins.	29	16	15	60	2	89	26	117	0	0	0	0	13	99	52	164
+30 mins.	13	3	16	32	4	86	16	106	0	0	0	0	13	85	18	116
+45 mins.	32	1	20	53	4	68	15	87	0	0	1	1	13	96	1	110
Total Volume	103	30	62	195	11	293	75	379	0	0	1	1	59	379	116	554
% App. Total	52.8	15.4	31.8		2.9	77.3	19.8		0	0	100		10.6	68.4	20.9	
PHF	.805	.469	.775	.813	.688	.823	.721	.810	.000	.000	.250	.250	.738	.957	.558	.845

City of Imperial
 N/S: La Brucherie Road/B Street
 E/W: Worthington Road
 Weather: Clear

File Name : 07_IPL_La B_Worthington PM
 Site Code : 99921570
 Start Date : 10/13/2021
 Page No : 1

Groups Printed- Total Volume

Start Time	La Brucherie Road Southbound				Worthington Road Westbound				B Street Northbound				Worthington Road Eastbound				Int. Total
	Left	Thru	Right	App. Total	Left	Thru	Right	App. Total	Left	Thru	Right	App. Total	Left	Thru	Right	App. Total	
04:00 PM	13	2	6	21	0	41	9	50	0	0	0	0	4	38	1	43	114
04:15 PM	6	0	5	11	0	40	7	47	0	0	0	0	11	36	0	47	105
04:30 PM	3	0	2	5	3	42	8	53	0	0	0	0	6	27	1	34	92
04:45 PM	8	1	7	16	1	50	7	58	0	0	0	0	5	46	1	52	126
Total	30	3	20	53	4	173	31	208	0	0	0	0	26	147	3	176	437
05:00 PM	11	1	3	15	0	50	7	57	0	0	0	0	5	33	3	41	113
05:15 PM	4	1	5	10	6	57	4	67	0	0	0	0	6	44	15	65	142
05:30 PM	15	2	7	24	8	61	12	81	0	0	0	0	8	57	8	73	178
05:45 PM	6	1	8	15	12	41	10	63	1	0	0	1	6	48	6	60	139
Total	36	5	23	64	26	209	33	268	1	0	0	1	25	182	32	239	572
Grand Total	66	8	43	117	30	382	64	476	1	0	0	1	51	329	35	415	1009
Apprch %	56.4	6.8	36.8		6.3	80.3	13.4		100	0	0		12.3	79.3	8.4		
Total %	6.5	0.8	4.3	11.6	3	37.9	6.3	47.2	0.1	0	0	0.1	5.1	32.6	3.5	41.1	

Start Time	La Brucherie Road Southbound				Worthington Road Westbound				B Street Northbound				Worthington Road Eastbound				Int. Total
	Left	Thru	Right	App. Total	Left	Thru	Right	App. Total	Left	Thru	Right	App. Total	Left	Thru	Right	App. Total	
Peak Hour Analysis From 04:00 PM to 05:45 PM - Peak 1 of 1																	
Peak Hour for Entire Intersection Begins at 05:00 PM																	
05:00 PM	11	1	3	15	0	50	7	57	0	0	0	0	5	33	3	41	113
05:15 PM	4	1	5	10	6	57	4	67	0	0	0	0	6	44	15	65	142
05:30 PM	15	2	7	24	8	61	12	81	0	0	0	0	8	57	8	73	178
05:45 PM	6	1	8	15	12	41	10	63	1	0	0	1	6	48	6	60	139
Total Volume	36	5	23	64	26	209	33	268	1	0	0	1	25	182	32	239	572
% App. Total	56.2	7.8	35.9		9.7	78	12.3		100	0	0		10.5	76.2	13.4		
PHF	.600	.625	.719	.667	.542	.857	.688	.827	.250	.000	.000	.250	.781	.798	.533	.818	.803

City of Imperial
 N/S: La Brucherie Road/B Street
 E/W: Worthington Road
 Weather: Clear

File Name : 07_IPL_La B_Worthington PM
 Site Code : 99921570
 Start Date : 10/13/2021
 Page No : 2

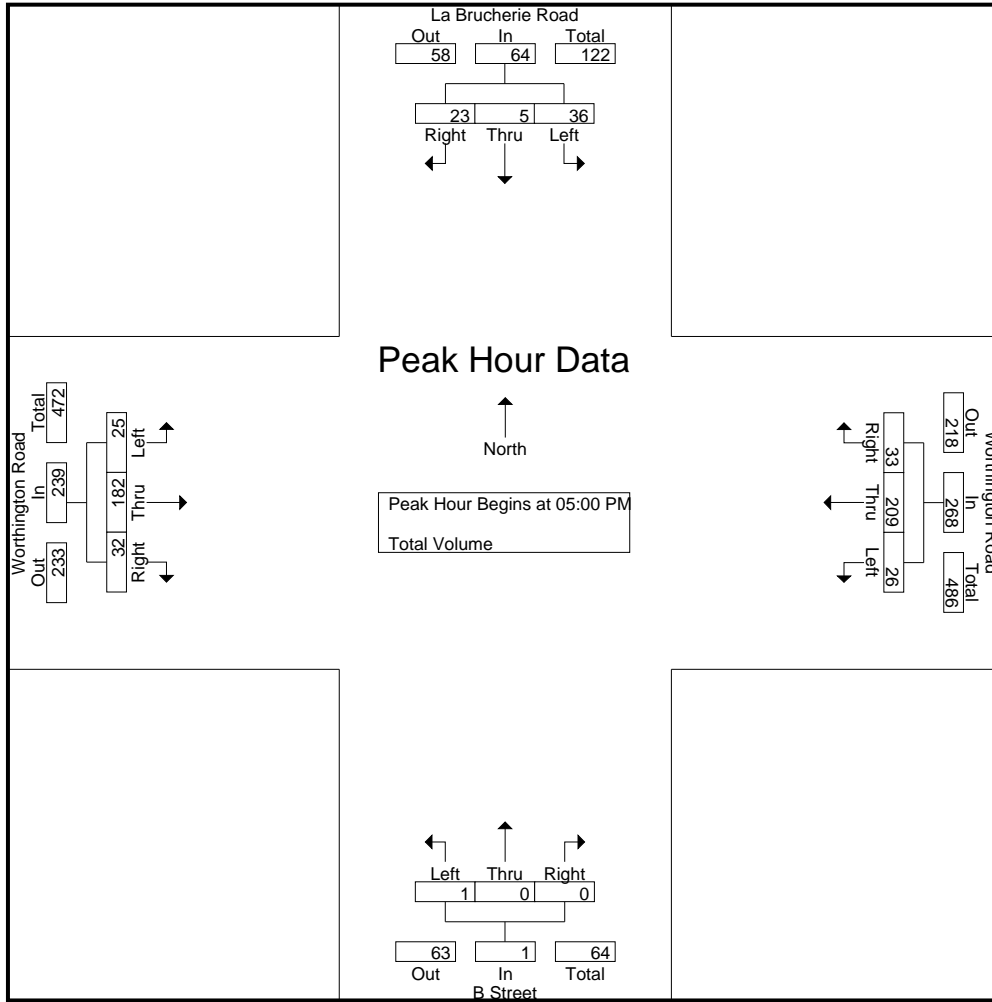

Peak Hour Analysis From 04:00 PM to 05:45 PM - Peak 1 of 1
 Peak Hour for Each Approach Begins at:

	04:45 PM				05:00 PM				05:00 PM				05:00 PM			
+0 mins.	8	1	7	16	0	50	7	57	0	0	0	0	5	33	3	41
+15 mins.	11	1	3	15	6	57	4	67	0	0	0	0	6	44	15	65
+30 mins.	4	1	5	10	8	61	12	81	0	0	0	0	8	57	8	73
+45 mins.	15	2	7	24	12	41	10	63	1	0	0	1	6	48	6	60
Total Volume	38	5	22	65	26	209	33	268	1	0	0	1	25	182	32	239
% App. Total	58.5	7.7	33.8		9.7	78	12.3		100	0	0		10.5	76.2	13.4	
PHF	.633	.625	.786	.677	.542	.857	.688	.827	.250	.000	.000	.250	.781	.798	.533	.818

City of Imperial
 N/S: SR-86 (Imperial Avenue)
 E/W: Aten Road
 Weather: Clear

File Name : 08_IPL_SR-86_Aten AM
 Site Code : 99921570
 Start Date : 10/13/2021
 Page No : 1

Groups Printed- Total Volume

Start Time	SR-86 Southbound				Aten Road Westbound				SR-86 Northbound				Aten Road Eastbound				Int. Total
	Left	Thru	Right	App. Total	Left	Thru	Right	App. Total	Left	Thru	Right	App. Total	Left	Thru	Right	App. Total	
07:00 AM	13	69	31	113	21	32	30	83	3	61	11	75	27	44	11	82	353
07:15 AM	26	99	42	167	14	55	32	101	9	73	8	90	50	67	11	128	486
07:30 AM	28	170	93	291	21	80	40	141	7	102	11	120	65	87	10	162	714
07:45 AM	39	185	123	347	21	95	44	160	13	83	20	116	54	102	14	170	793
Total	106	523	289	918	77	262	146	485	32	319	50	401	196	300	46	542	2346
08:00 AM	40	158	88	286	45	71	23	139	20	81	15	116	46	72	19	137	678
08:15 AM	31	139	61	231	40	45	30	115	19	68	19	106	16	67	18	101	553
08:30 AM	20	121	35	176	36	40	25	101	13	92	27	132	37	47	12	96	505
08:45 AM	25	122	34	181	30	50	18	98	18	83	20	121	26	49	11	86	486
Total	116	540	218	874	151	206	96	453	70	324	81	475	125	235	60	420	2222
Grand Total	222	1063	507	1792	228	468	242	938	102	643	131	876	321	535	106	962	4568
Apprch %	12.4	59.3	28.3		24.3	49.9	25.8		11.6	73.4	15		33.4	55.6	11		
Total %	4.9	23.3	11.1	39.2	5	10.2	5.3	20.5	2.2	14.1	2.9	19.2	7	11.7	2.3	21.1	

Start Time	SR-86 Southbound				Aten Road Westbound				SR-86 Northbound				Aten Road Eastbound				Int. Total
	Left	Thru	Right	App. Total	Left	Thru	Right	App. Total	Left	Thru	Right	App. Total	Left	Thru	Right	App. Total	
Peak Hour Analysis From 07:00 AM to 08:45 AM - Peak 1 of 1																	
Peak Hour for Entire Intersection Begins at 07:30 AM																	
07:30 AM	28	170	93	291	21	80	40	141	7	102	11	120	65	87	10	162	714
07:45 AM	39	185	123	347	21	95	44	160	13	83	20	116	54	102	14	170	793
08:00 AM	40	158	88	286	45	71	23	139	20	81	15	116	46	72	19	137	678
08:15 AM	31	139	61	231	40	45	30	115	19	68	19	106	16	67	18	101	553
Total Volume	138	652	365	1155	127	291	137	555	59	334	65	458	181	328	61	570	2738
% App. Total	11.9	56.5	31.6		22.9	52.4	24.7		12.9	72.9	14.2		31.8	57.5	10.7		
PHF	.863	.881	.742	.832	.706	.766	.778	.867	.738	.819	.813	.954	.696	.804	.803	.838	.863

City of Imperial
 N/S: SR-86 (Imperial Avenue)
 E/W: Aten Road
 Weather: Clear

File Name : 08_IPL_SR-86_Aten AM
 Site Code : 99921570
 Start Date : 10/13/2021
 Page No : 2

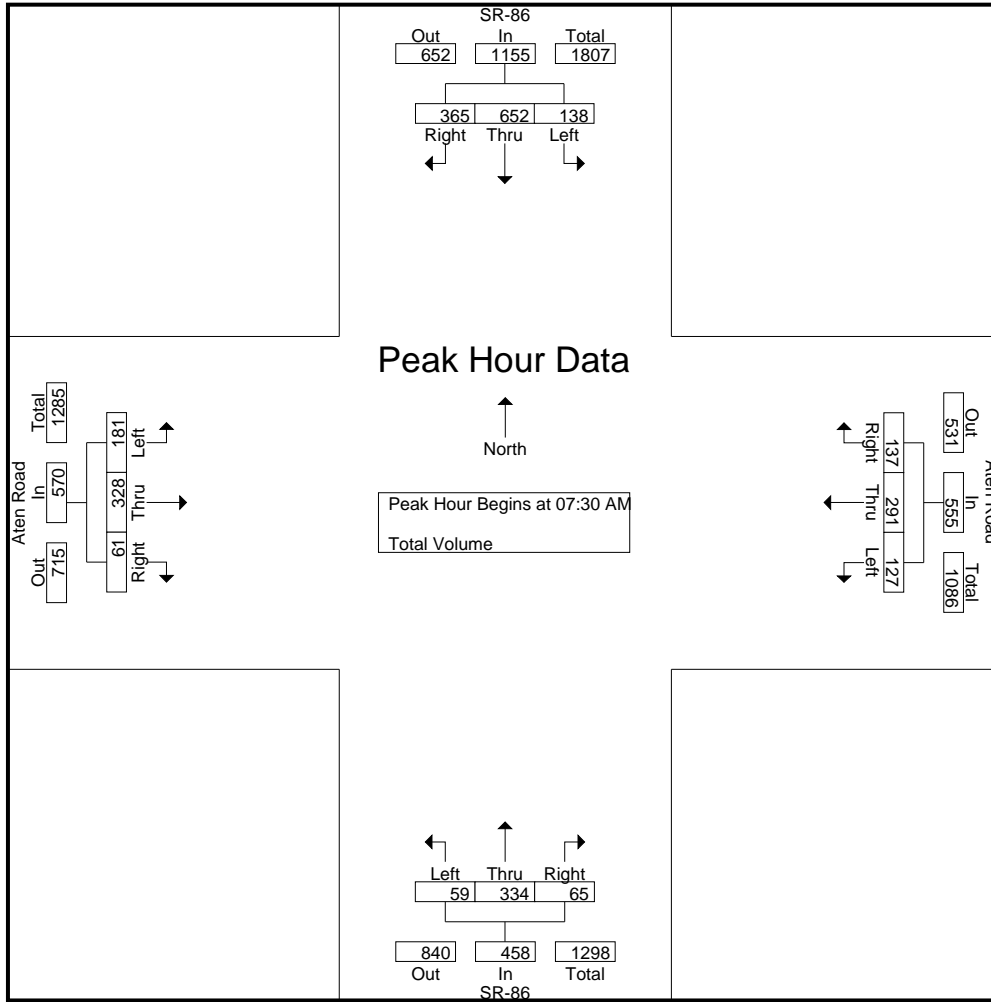

Peak Hour Analysis From 07:00 AM to 08:45 AM - Peak 1 of 1
 Peak Hour for Each Approach Begins at:

	07:30 AM				07:30 AM				08:00 AM				07:15 AM			
+0 mins.	28	170	93	291	21	80	40	141	20	81	15	116	50	67	11	128
+15 mins.	39	185	123	347	21	95	44	160	19	68	19	106	65	87	10	162
+30 mins.	40	158	88	286	45	71	23	139	13	92	27	132	54	102	14	170
+45 mins.	31	139	61	231	40	45	30	115	18	83	20	121	46	72	19	137
Total Volume	138	652	365	1155	127	291	137	555	70	324	81	475	215	328	54	597
% App. Total	11.9	56.5	31.6		22.9	52.4	24.7		14.7	68.2	17.1		36	54.9	9	
PHF	.863	.881	.742	.832	.706	.766	.778	.867	.875	.880	.750	.900	.827	.804	.711	.878

City of Imperial
 N/S: SR-86 (Imperial Avenue)
 E/W: Aten Road
 Weather: Clear

File Name : 08_IPL_SR-86_Aten PM
 Site Code : 99921570
 Start Date : 10/13/2021
 Page No : 1

Groups Printed- Total Volume

Start Time	SR-86 Southbound				Aten Road Westbound				SR-86 Northbound				Aten Road Eastbound				Int. Total
	Left	Thru	Right	App. Total	Left	Thru	Right	App. Total	Left	Thru	Right	App. Total	Left	Thru	Right	App. Total	
04:00 PM	24	139	38	201	44	74	26	144	14	156	35	205	47	62	21	130	680
04:15 PM	30	126	28	184	33	79	18	130	23	148	31	202	28	56	18	102	618
04:30 PM	16	127	32	175	48	69	26	143	11	125	33	169	48	60	23	131	618
04:45 PM	24	130	30	184	35	67	28	130	18	141	32	191	46	62	11	119	624
Total	94	522	128	744	160	289	98	547	66	570	131	767	169	240	73	482	2540
05:00 PM	22	109	63	194	42	68	23	133	24	142	43	209	49	80	20	149	685
05:15 PM	29	141	56	226	50	87	35	172	14	170	31	215	46	66	21	133	746
05:30 PM	34	143	54	231	46	58	33	137	20	193	39	252	43	60	14	117	737
05:45 PM	30	112	52	194	34	57	35	126	12	145	32	189	38	61	9	108	617
Total	115	505	225	845	172	270	126	568	70	650	145	865	176	267	64	507	2785
Grand Total	209	1027	353	1589	332	559	224	1115	136	1220	276	1632	345	507	137	989	5325
Apprch %	13.2	64.6	22.2		29.8	50.1	20.1		8.3	74.8	16.9		34.9	51.3	13.9		
Total %	3.9	19.3	6.6	29.8	6.2	10.5	4.2	20.9	2.6	22.9	5.2	30.6	6.5	9.5	2.6	18.6	

Start Time	SR-86 Southbound				Aten Road Westbound				SR-86 Northbound				Aten Road Eastbound				Int. Total
	Left	Thru	Right	App. Total	Left	Thru	Right	App. Total	Left	Thru	Right	App. Total	Left	Thru	Right	App. Total	
Peak Hour Analysis From 04:00 PM to 05:45 PM - Peak 1 of 1																	
Peak Hour for Entire Intersection Begins at 04:45 PM																	
04:45 PM	24	130	30	184	35	67	28	130	18	141	32	191	46	62	11	119	624
05:00 PM	22	109	63	194	42	68	23	133	24	142	43	209	49	80	20	149	685
05:15 PM	29	141	56	226	50	87	35	172	14	170	31	215	46	66	21	133	746
05:30 PM	34	143	54	231	46	58	33	137	20	193	39	252	43	60	14	117	737
Total Volume	109	523	203	835	173	280	119	572	76	646	145	867	184	268	66	518	2792
% App. Total	13.1	62.6	24.3		30.2	49	20.8		8.8	74.5	16.7		35.5	51.7	12.7		
PHF	.801	.914	.806	.904	.865	.805	.850	.831	.792	.837	.843	.860	.939	.838	.786	.869	.936

City of Imperial
 N/S: SR-86 (Imperial Avenue)
 E/W: Aten Road
 Weather: Clear

File Name : 08_IPL_SR-86_Aten PM
 Site Code : 99921570
 Start Date : 10/13/2021
 Page No : 2

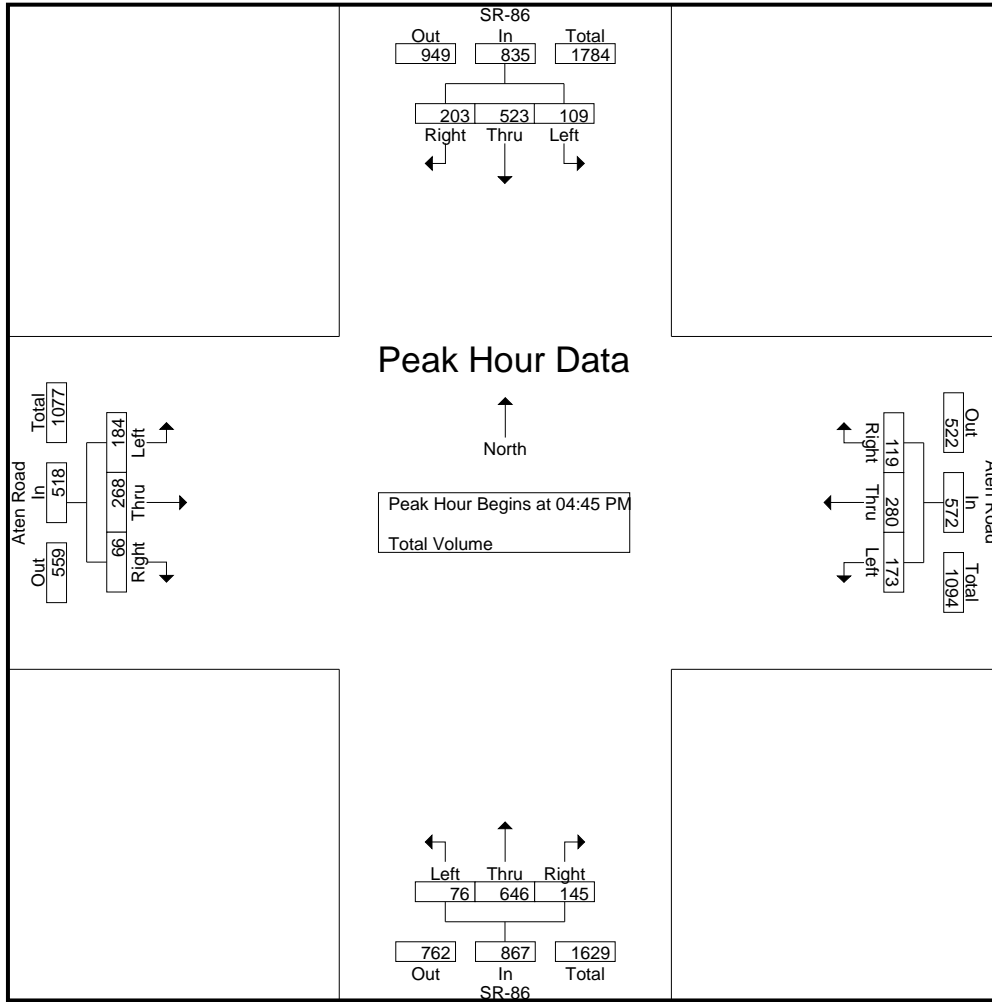

Peak Hour Analysis From 04:00 PM to 05:45 PM - Peak 1 of 1
 Peak Hour for Each Approach Begins at:

	05:00 PM				04:30 PM				04:45 PM				04:30 PM			
+0 mins.	22	109	63	194	48	69	26	143	18	141	32	191	48	60	23	131
+15 mins.	29	141	56	226	35	67	28	130	24	142	43	209	46	62	11	119
+30 mins.	34	143	54	231	42	68	23	133	14	170	31	215	49	80	20	149
+45 mins.	30	112	52	194	50	87	35	172	20	193	39	252	46	66	21	133
Total Volume	115	505	225	845	175	291	112	578	76	646	145	867	189	268	75	532
% App. Total	13.6	59.8	26.6		30.3	50.3	19.4		8.8	74.5	16.7		35.5	50.4	14.1	
PHF	.846	.883	.893	.915	.875	.836	.800	.840	.792	.837	.843	.860	.964	.838	.815	.893

Counts Unlimited, Inc.

City of Imperial
 La Brucherie Road
 B/ Ralph Road - Neckel Road
 24 Hour Directional Volume Count

PO Box 1178
 Corona, CA 92878
 Phone: (951) 268-6268
 email: counts@countsunlimited.com

IPL002
 Site Code: 999-21570

Start Time	13-Oct-21 Wed	Northbound		Hour Totals		Southbound		Hour Totals		Combined Totals	
		Morning	Afternoon	Morning	Afternoon	Morning	Afternoon	Morning	Afternoon	Morning	Afternoon
12:00		0	4			0	1				
12:15		0	3			0	1				
12:30		0	5			0	2				
12:45		0	4	0	16	0	3	0	7	0	23
01:00		0	1			0	2				
01:15		0	3			0	3				
01:30		1	3			0	1				
01:45		0	2	1	9	0	1	0	7	1	16
02:00		1	4			0	2				
02:15		0	2			0	2				
02:30		0	2			1	2				
02:45		0	3	1	11	0	3	1	9	2	20
03:00		0	2			0	1				
03:15		0	3			0	2				
03:30		2	2			0	2				
03:45		0	1	2	8	0	5	0	10	2	18
04:00		0	1			0	2				
04:15		0	2			0	2				
04:30		0	4			0	2				
04:45		0	2	0	9	0	6	0	12	0	21
05:00		0	1			0	2				
05:15		2	4			0	2				
05:30		3	2			1	4				
05:45		3	1	8	8	5	3	6	11	14	19
06:00		1	2			2	3				
06:15		4	2			1	1				
06:30		3	1			0	2				
06:45		4	1	12	6	0	0	3	6	15	12
07:00		4	0			0	1				
07:15		2	0			1	2				
07:30		2	1			1	0				
07:45		3	2	11	3	0	0	2	3	13	6
08:00		1	1			1	0				
08:15		4	0			2	0				
08:30		2	1			1	0				
08:45		4	0	11	2	0	0	4	0	15	2
09:00		4	2			1	1				
09:15		3	0			1	0				
09:30		2	1			2	0				
09:45		2	1	11	4	0	0	4	1	15	5
10:00		2	1			1	1				
10:15		4	3			0	0				
10:30		2	1			1	0				
10:45		3	0	11	5	0	0	2	1	13	6
11:00		5	1			1	0				
11:15		2	0			2	0				
11:30		2	0			2	0				
11:45		0	1	9	2	0	0	5	0	14	2
Total		77	83	77	83	27	67	27	67	104	150
Combined Total		160		160		94		94		254	
AM Peak	-	06:15	-	-	-	05:30	-	-	-	-	-
Vol.	-	15	-	-	-	9	-	-	-	-	-
P.H.F.	-	0.938	-	-	-	0.450	-	-	-	-	-
PM Peak	-	-	12:00	-	-	-	04:45	-	-	-	-
Vol.	-	-	16	-	-	-	14	-	-	-	-
P.H.F.	-	-	0.800	-	-	-	0.583	-	-	-	-
Percentage		48.1%	51.9%			28.7%	71.3%				
ADT/AADT		ADT 254		AADT 254							

Counts Unlimited, Inc.

City of Imperial
 Ralph Road
 B/ State Route 86 - Clark Road
 24 Hour Directional Volume Count

PO Box 1178
 Corona, CA 92878
 Phone: (951) 268-6268
 email: counts@countsunlimited.com

IPL003
 Site Code: 999-21570

Start Time	13-Oct-21 Wed	Eastbound		Hour Totals		Westbound		Hour Totals		Combined Totals	
		Morning	Afternoon	Morning	Afternoon	Morning	Afternoon	Morning	Afternoon	Morning	Afternoon
12:00		0	13			2	10				
12:15		0	5			0	13				
12:30		0	10			0	13				
12:45		0	17	0	45	0	15	2	51	2	96
01:00		2	17			0	12				
01:15		2	13			0	9				
01:30		1	11			4	4				
01:45		1	15	6	56	1	8	5	33	11	89
02:00		0	9			0	14				
02:15		0	8			1	7				
02:30		0	14			0	13				
02:45		0	11	0	42	1	8	2	42	2	84
03:00		1	7			2	10				
03:15		0	15			0	14				
03:30		1	15			3	5				
03:45		0	15	2	52	3	10	8	39	10	91
04:00		1	13			0	12				
04:15		1	9			1	8				
04:30		1	16			1	16				
04:45		1	12	4	50	2	5	4	41	8	91
05:00		0	16			6	6				
05:15		7	18			9	9				
05:30		1	12			6	9				
05:45		2	8	10	54	12	10	33	34	43	88
06:00		1	10			11	7				
06:15		4	9			1	11				
06:30		6	16			8	6				
06:45		1	12	12	47	16	5	36	29	48	76
07:00		7	17			15	6				
07:15		13	12			15	9				
07:30		13	8			20	6				
07:45		11	14	44	51	26	3	76	24	120	75
08:00		22	8			18	4				
08:15		11	7			14	5				
08:30		7	6			8	1				
08:45		5	4	45	25	10	3	50	13	95	38
09:00		8	6			2	9				
09:15		8	3			9	7				
09:30		7	5			8	4				
09:45		6	5	29	19	7	5	26	25	55	44
10:00		3	2			4	1				
10:15		3	1			6	0				
10:30		6	2			5	1				
10:45		8	3	20	8	7	1	22	3	42	11
11:00		7	2			6	0				
11:15		9	0			10	1				
11:30		5	1			7	1				
11:45		7	0	28	3	5	3	28	5	56	8
Total		200	452	200	452	292	339	292	339	492	791
Combined Total		652		652		631		631		1283	
AM Peak	-	07:15	-	-	-	07:15	-	-	-	-	-
Vol.	-	59	-	-	-	79	-	-	-	-	-
P.H.F.		0.670				0.760					
PM Peak	-	-	04:30	-	-	-	00:15	-	-	-	-
Vol.	-	-	62	-	-	-	53	-	-	-	-
P.H.F.			0.861				0.883				
Percentage		30.7%	69.3%			46.3%	53.7%				
ADT/AADT		ADT 1,283		AADT 1,283							

Counts Unlimited, Inc.

City of Imperial
 State Route 86
 B/ Barioni Boulevard - Aten Road
 24 Hour Directional Volume Count

PO Box 1178
 Corona, CA 92878
 Phone: (951) 268-6268
 email: counts@countsunlimited.com

IPL006
 Site Code: 999-21570

Start Time	13-Oct-21 Wed	Northbound		Hour Totals		Southbound		Hour Totals		Combined Totals	
		Morning	Afternoon	Morning	Afternoon	Morning	Afternoon	Morning	Afternoon	Morning	Afternoon
12:00		21	175			12	183				
12:15		10	181			8	163				
12:30		8	183			5	219				
12:45		9	210	48	749	14	260	39	825	87	1574
01:00		12	195			7	214				
01:15		5	165			8	200				
01:30		6	206			5	175				
01:45		8	167	31	733	10	160	30	749	61	1482
02:00		7	183			7	154				
02:15		6	152			4	187				
02:30		6	155			8	195				
02:45		7	160	26	650	9	194	28	730	54	1380
03:00		6	150			6	188				
03:15		12	161			13	209				
03:30		10	147			10	212				
03:45		13	141	41	599	17	208	46	817	87	1416
04:00		10	170			9	182				
04:15		20	176			15	165				
04:30		26	159			14	175				
04:45		40	178	96	683	40	151	78	673	174	1356
05:00		47	195			33	185				
05:15		77	196			38	218				
05:30		65	191			63	172				
05:45		89	189	278	771	71	157	205	732	483	1503
06:00		58	169			68	138				
06:15		63	141			49	150				
06:30		90	144			79	149				
06:45		123	147	334	601	116	123	312	560	646	1161
07:00		94	147			100	123				
07:15		126	123			172	107				
07:30		173	121			250	126				
07:45		175	115	568	506	229	107	751	463	1319	969
08:00		126	108			216	71				
08:15		117	118			177	79				
08:30		117	109			165	80				
08:45		102	118	462	453	148	64	706	294	1168	747
09:00		103	104			126	51				
09:15		96	72			142	58				
09:30		95	80			148	64				
09:45		111	45	405	301	161	52	577	225	982	526
10:00		127	46			152	42				
10:15		92	46			162	46				
10:30		122	46			145	34				
10:45		130	39	471	177	161	18	620	140	1091	317
11:00		134	25			130	18				
11:15		146	21			179	19				
11:30		141	22			182	15				
11:45		172	19	593	87	161	19	652	71	1245	158
Total		3353	6310	3353	6310	4044	6279	4044	6279	7397	12589
Combined Total		9663		9663		10323		10323		19986	
AM Peak	-	07:15	-	-	-	07:30	-	-	-	-	-
Vol.	-	600	-	-	-	872	-	-	-	-	-
P.H.F.	-	0.857	-	-	-	0.872	-	-	-	-	-
PM Peak	-	-	00:45	-	-	-	00:30	-	-	-	-
Vol.	-	-	776	-	-	-	893	-	-	-	-
P.H.F.	-	-	0.924	-	-	-	0.859	-	-	-	-
Percentage		34.7%	65.3%			39.2%	60.8%				
ADT/AADT		ADT 19,986	AADT 19,986								

Counts Unlimited, Inc.

City of Imperial
 State Route 86
 B/ Keystone Road - Larsen Road
 24 Hour Directional Volume Count

PO Box 1178
 Corona, CA 92878
 Phone: (951) 268-6268
 email: counts@countsunlimited.com

IPL007
 Site Code: 999-21570

Start Time	13-Oct-21 Wed	Northbound		Hour Totals		Southbound		Hour Totals		Combined Totals	
		Morning	Afternoon	Morning	Afternoon	Morning	Afternoon	Morning	Afternoon	Morning	Afternoon
12:00		11	95			9	113				
12:15		11	118			7	98				
12:30		6	108			9	140				
12:45		10	127	38	448	11	133	36	484	74	932
01:00		9	127			5	114				
01:15		7	111			8	101				
01:30		6	152			4	112				
01:45		7	124	29	514	6	119	23	446	52	960
02:00		3	130			3	99				
02:15		6	129			6	143				
02:30		6	106			3	128				
02:45		8	125	23	490	9	152	21	522	44	1012
03:00		8	121			4	127				
03:15		11	102			10	156				
03:30		12	141			11	185				
03:45		14	112	45	476	12	142	37	610	82	1086
04:00		14	117			7	124				
04:15		16	133			12	134				
04:30		28	112			17	119				
04:45		29	146	87	508	26	156	62	533	149	1041
05:00		41	141			25	135				
05:15		71	145			30	168				
05:30		70	118			62	121				
05:45		67	157	249	561	68	79	185	503	434	1064
06:00		68	126			42	90				
06:15		72	94			45	102				
06:30		93	98			82	77				
06:45		124	110	357	428	75	90	244	359	601	787
07:00		103	83			90	67				
07:15		133	90			128	71				
07:30		128	71			137	63				
07:45		153	67	517	311	132	58	487	259	1004	570
08:00		79	73			130	52				
08:15		112	61			98	49				
08:30		88	62			95	46				
08:45		96	80	375	276	94	36	417	183	792	459
09:00		88	71			99	42				
09:15		93	62			95	40				
09:30		68	50			120	41				
09:45		82	36	331	219	97	27	411	150	742	369
10:00		89	28			113	32				
10:15		69	35			91	29				
10:30		99	31			111	18				
10:45		93	31	350	125	95	15	410	94	760	219
11:00		94	18			105	12				
11:15		122	13			107	22				
11:30		110	16			93	11				
11:45		118	13	444	60	104	14	409	59	853	119
Total		2845	4416	2845	4416	2742	4202	2742	4202	5587	8618
Combined Total		7261		7261		6944		6944		14205	
AM Peak	-	07:00	-	-	-	07:15	-	-	-	-	-
Vol.	-	517	-	-	-	527	-	-	-	-	-
P.H.F.		0.845				0.962					
PM Peak	-	-	05:00	-	-	-	02:45	-	-	-	-
Vol.	-	-	561	-	-	-	620	-	-	-	-
P.H.F.			0.893				0.838				
Percentage		39.2%	60.8%			39.5%	60.5%				
ADT/AADT		ADT 14,205	AADT 14,205								

Counts Unlimited, Inc.

City of Imperial
 State Route 86
 B/ Larsen Road - Ralph Road
 24 Hour Directional Volume Count

PO Box 1178
 Corona, CA 92878
 Phone: (951) 268-6268
 email: counts@countsunlimited.com

IPL004
 Site Code: 999-21570

Start Time	13-Oct-21 Wed	Northbound		Hour Totals		Southbound		Hour Totals		Combined Totals	
		Morning	Afternoon	Morning	Afternoon	Morning	Afternoon	Morning	Afternoon	Morning	Afternoon
12:00		11	102			9	112				
12:15		9	109			8	96				
12:30		6	111			7	131				
12:45		9	126	35	448	13	130	37	469	72	917
01:00		10	118			3	106				
01:15		8	111			9	103				
01:30		4	140			2	98				
01:45		7	118	29	487	7	110	21	417	50	904
02:00		5	134			3	97				
02:15		7	102			4	139				
02:30		4	107			5	121				
02:45		8	121	24	464	10	147	22	504	46	968
03:00		9	104			4	123				
03:15		12	102			6	155				
03:30		12	116			11	158				
03:45		12	115	45	437	15	173	36	609	81	1046
04:00		12	108			7	137				
04:15		19	133			8	131				
04:30		23	120			13	124				
04:45		33	119	87	480	28	131	56	523	143	1003
05:00		42	147			24	146				
05:15		71	138			27	159				
05:30		62	153			44	120				
05:45		79	143	254	581	67	95	162	520	416	1101
06:00		66	117			42	70				
06:15		73	96			35	109				
06:30		110	85			69	70				
06:45		123	94	372	392	67	67	213	316	585	708
07:00		96	78			67	67				
07:15		124	85			119	64				
07:30		142	65			137	59				
07:45		132	70	494	298	126	54	449	244	943	542
08:00		95	62			113	55				
08:15		94	56			92	46				
08:30		82	55			105	47				
08:45		101	75	372	248	87	33	397	181	769	429
09:00		77	60			88	39				
09:15		80	56			87	49				
09:30		65	45			113	39				
09:45		68	23	290	184	108	35	396	162	686	346
10:00		92	38			115	38				
10:15		66	24			85	29				
10:30		87	30			104	23				
10:45		86	23	331	115	98	15	402	105	733	220
11:00		90	16			109	12				
11:15		119	14			103	16				
11:30		92	18			100	17				
11:45		108	15	409	63	99	13	411	58	820	121
Total		2742	4197	2742	4197	2602	4108	2602	4108	5344	8305
Combined Total		6939		6939		6710		6710		13649	
AM Peak	-	07:00	-	-	-	07:15	-	-	-	-	-
Vol.	-	494	-	-	-	495	-	-	-	-	-
P.H.F.		0.870				0.903					
PM Peak	-	-	05:00	-	-	-	03:15	-	-	-	-
Vol.	-	-	581	-	-	-	623	-	-	-	-
P.H.F.			0.949				0.900				
Percentage		39.5%	60.5%			38.8%	61.2%				
ADT/AADT		ADT 13,649	AADT 13,649								

Counts Unlimited, Inc.

City of Imperial
 State Route 86
 B/ Neckel Road - Barioni Boulevard
 24 Hour Directional Volume Count

PO Box 1178
 Corona, CA 92878
 Phone: (951) 268-6268
 email: counts@countsunlimited.com

IPL005
 Site Code: 999-21570

Start Time	13-Oct-21 Wed	Northbound		Hour Totals		Southbound		Hour Totals		Combined Totals	
		Morning	Afternoon	Morning	Afternoon	Morning	Afternoon	Morning	Afternoon	Morning	Afternoon
12:00		21	167			14	144				
12:15		11	176			7	150				
12:30		8	187			4	193				
12:45		10	197	50	727	13	240	38	727	88	1454
01:00		10	181			7	180				
01:15		7	159			9	168				
01:30		6	189			7	154				
01:45		6	167	29	696	7	129	30	631	59	1327
02:00		7	169			5	131				
02:15		8	150			5	151				
02:30		3	152			6	167				
02:45		5	140	23	611	10	160	26	609	49	1220
03:00		5	130			5	158				
03:15		12	148			9	191				
03:30		13	149			12	195				
03:45		15	131	45	558	17	178	43	722	88	1280
04:00		9	171			10	162				
04:15		18	176			14	137				
04:30		28	149			16	148				
04:45		40	163	95	659	38	139	78	586	173	1245
05:00		47	188			29	161				
05:15		71	189			42	217				
05:30		59	177			51	144				
05:45		73	191	250	745	70	142	192	664	442	1409
06:00		54	166			58	112				
06:15		73	129			45	131				
06:30		79	125			77	135				
06:45		114	137	320	557	106	101	286	479	606	1036
07:00		94	124			93	98				
07:15		125	116			147	92				
07:30		168	104			208	95				
07:45		186	112	573	456	178	91	626	376	1199	832
08:00		117	106			168	67				
08:15		124	117			151	63				
08:30		110	114			141	64				
08:45		101	113	452	450	134	57	594	251	1046	701
09:00		106	97			111	51				
09:15		103	67			120	46				
09:30		78	76			133	66				
09:45		96	43	383	283	143	45	507	208	890	491
10:00		117	45			135	45				
10:15		85	41			139	36				
10:30		108	43			118	28				
10:45		118	34	428	163	139	18	531	127	959	290
11:00		123	20			113	16				
11:15		138	21			151	20				
11:30		139	23			151	18				
11:45		162	18	562	82	126	22	541	76	1103	158
Total		3210	5987	3210	5987	3492	5456	3492	5456	6702	11443
Combined Total		9197		9197		8948		8948		18145	
AM Peak	-	07:15	-	-	-	07:30	-	-	-	-	-
Vol.	-	596	-	-	-	705	-	-	-	-	-
P.H.F.	-	0.801	-	-	-	0.847	-	-	-	-	-
PM Peak	-	-	05:00	-	-	-	00:30	-	-	-	-
Vol.	-	-	745	-	-	-	781	-	-	-	-
P.H.F.	-	-	0.945	-	-	-	0.814	-	-	-	-
Percentage		34.9%	65.1%			39.0%	61.0%				
ADT/AADT		ADT 18,145	AADT 18,145								

Counts Unlimited, Inc.

City of Imperial
 State Route 86
 B/ Ralph Road - Neckel Road
 24 Hour Directional Volume Count

PO Box 1178
 Corona, CA 92878
 Phone: (951) 268-6268
 email: counts@countsunlimited.com

IPL001
 Site Code: 999-21570

Start Time	13-Oct-21 Wed	Northbound		Hour Totals		Southbound		Hour Totals		Combined Totals	
		Morning	Afternoon	Morning	Afternoon	Morning	Afternoon	Morning	Afternoon	Morning	Afternoon
12:00		11	106			11	113				
12:15		9	109			8	104				
12:30		6	112			7	135				
12:45		9	138	35	465	13	140	39	492	74	957
01:00		12	129			3	112				
01:15		9	121			8	109				
01:30		4	146			5	97				
01:45		6	123	31	519	6	108	22	426	53	945
02:00		5	137			3	105				
02:15		7	106			5	142				
02:30		4	116			5	129				
02:45		7	124	23	483	10	147	23	523	46	1006
03:00		9	104			5	126				
03:15		12	110			6	162				
03:30		11	126			12	158				
03:45		10	118	42	458	16	171	39	617	81	1075
04:00		13	114			7	142				
04:15		19	134			8	130				
04:30		23	122			13	126				
04:45		33	120	88	490	29	125	57	523	145	1013
05:00		39	151			27	140				
05:15		65	150			23	162				
05:30		56	155			43	119				
05:45		76	144	236	600	74	98	167	519	403	1119
06:00		61	124			47	74				
06:15		74	99			33	114				
06:30		109	95			70	70				
06:45		118	103	362	421	77	69	227	327	589	748
07:00		91	89			70	67				
07:15		125	91			122	67				
07:30		144	71			146	63				
07:45		133	80	493	331	142	53	480	250	973	581
08:00		109	67			123	56				
08:15		100	58			101	46				
08:30		82	60			106	47				
08:45		100	79	391	264	91	36	421	185	812	449
09:00		80	56			85	38				
09:15		82	54			90	51				
09:30		67	50			115	43				
09:45		70	23	299	183	111	35	401	167	700	350
10:00		91	39			115	38				
10:15		66	25			88	29				
10:30		89	31			105	23				
10:45		91	23	337	118	102	13	410	103	747	221
11:00		94	18			112	12				
11:15		123	13			108	16				
11:30		95	19			105	18				
11:45		109	14	421	64	98	15	423	61	844	125
Total		2758	4396	2758	4396	2709	4193	2709	4193	5467	8589
Combined Total		7154		7154		6902		6902		14056	
AM Peak	-	07:15	-	-	-	07:15	-	-	-	-	-
Vol.	-	511	-	-	-	533	-	-	-	-	-
P.H.F.	-	0.887	-	-	-	0.913	-	-	-	-	-
PM Peak	-	-	05:00	-	-	-	03:15	-	-	-	-
Vol.	-	-	600	-	-	-	633	-	-	-	-
P.H.F.	-	-	0.968	-	-	-	0.925	-	-	-	-
Percentage		38.6%	61.4%			39.2%	60.8%				
ADT/AADT		ADT 14,056	AADT 14,056								

Counts Unlimited, Inc.

City of Imperial
 State Route 86
 N/ Keystone Road
 24 Hour Directional Volume Count

PO Box 1178
 Corona, CA 92878
 Phone: (951) 268-6268
 email: counts@countsunlimited.com

IPL008
 Site Code: 999-21570

Start Time	13-Oct-21 Wed	Northbound		Hour Totals		Southbound		Hour Totals		Combined Totals	
		Morning	Afternoon	Morning	Afternoon	Morning	Afternoon	Morning	Afternoon	Morning	Afternoon
12:00		13	101			10	113				
12:15		13	125			7	100				
12:30		7	116			11	142				
12:45		10	121	43	463	11	141	39	496	82	959
01:00		10	132			6	122				
01:15		9	111			7	100				
01:30		5	159			4	110				
01:45		7	123	31	525	6	119	23	451	54	976
02:00		3	127			3	104				
02:15		7	136			4	142				
02:30		6	118			4	133				
02:45		9	136	25	517	10	159	21	538	46	1055
03:00		8	126			4	127				
03:15		11	113			13	140				
03:30		10	149			9	180				
03:45		10	128	39	516	12	141	38	588	77	1104
04:00		12	124			9	131				
04:15		15	145			13	140				
04:30		29	128			20	124				
04:45		23	158	79	555	33	163	75	558	154	1113
05:00		37	139			32	147				
05:15		65	160			38	177				
05:30		66	131			72	129				
05:45		68	162	236	592	71	82	213	535	449	1127
06:00		69	131			45	100				
06:15		71	102			54	108				
06:30		84	115			96	81				
06:45		120	121	344	469	87	82	282	371	626	840
07:00		106	84			95	73				
07:15		126	95			144	77				
07:30		136	80			158	70				
07:45		153	71	521	330	143	67	540	287	1061	617
08:00		85	76			133	62				
08:15		120	68			99	56				
08:30		100	64			97	49				
08:45		111	85	416	293	103	35	432	202	848	495
09:00		89	72			104	45				
09:15		92	62			101	44				
09:30		74	60			131	42				
09:45		80	38	335	232	99	30	435	161	770	393
10:00		92	31			120	35				
10:15		70	37			95	32				
10:30		110	36			114	19				
10:45		94	35	366	139	94	14	423	100	789	239
11:00		95	20			116	15				
11:15		117	15			113	22				
11:30		111	17			100	13				
11:45		117	12	440	64	109	15	438	65	878	129
Total		2875	4695	2875	4695	2959	4352	2959	4352	5834	9047
Combined Total		7570		7570		7311		7311		14881	
AM Peak	-	07:00	-	-	-	07:15	-	-	-	-	-
Vol.	-	521	-	-	-	578	-	-	-	-	-
P.H.F.	-	0.851	-	-	-	0.915	-	-	-	-	-
PM Peak	-	-	05:00	-	-	-	04:45	-	-	-	-
Vol.	-	-	592	-	-	-	616	-	-	-	-
P.H.F.	-	-	0.914	-	-	-	0.870	-	-	-	-
Percentage		38.0%	62.0%			40.5%	59.5%				
ADT/AADT		ADT 14,881	AADT 14,881								

Counts Unlimited, Inc.

City of Imperial
 State Route 86
 S/ Aten Road
 24 Hour Directional Volume Count

PO Box 1178
 Corona, CA 92878
 Phone: (951) 268-6268
 email: counts@countsunlimited.com

IPL009
 Site Code: 999-21570

Start Time	13-Oct-21 Wed	Northbound		Hour Totals		Southbound		Hour Totals		Combined Totals	
		Morning	Afternoon	Morning	Afternoon	Morning	Afternoon	Morning	Afternoon	Morning	Afternoon
12:00		14	190			12	204				
12:15		13	201			10	202				
12:30		8	195			9	222				
12:45		12	203	47	789	12	276	43	904	90	1693
01:00		7	176			6	268				
01:15		5	199			5	230				
01:30		6	216			3	188				
01:45		4	193	22	784	13	162	27	848	49	1632
02:00		7	204			7	190				
02:15		7	177			3	201				
02:30		2	172			10	205				
02:45		7	180	23	733	6	224	26	820	49	1553
03:00		3	176			4	190				
03:15		9	179			12	177				
03:30		5	199			9	217				
03:45		9	167	26	721	13	219	38	803	64	1524
04:00		11	205			9	204				
04:15		17	202			8	177				
04:30		17	169			13	198				
04:45		28	191	73	767	22	176	52	755	125	1522
05:00		37	209			22	171				
05:15		52	215			41	212				
05:30		41	252			29	203				
05:45		64	189	194	865	67	155	159	741	353	1606
06:00		40	182			53	150				
06:15		50	170			51	180				
06:30		84	180			70	187				
06:45		87	157	261	689	115	146	289	663	550	1352
07:00		75	176			101	138				
07:15		90	140			124	136				
07:30		120	145			201	119				
07:45		116	146	401	607	220	114	646	507	1047	1114
08:00		116	119			222	101				
08:15		106	121			197	89				
08:30		132	120			169	81				
08:45		121	116	475	476	163	68	751	339	1226	815
09:00		115	97			138	71				
09:15		114	63			159	57				
09:30		136	86			161	52				
09:45		128	62	493	308	206	58	664	238	1157	546
10:00		121	64			179	47				
10:15		115	46			187	48				
10:30		156	50			187	33				
10:45		154	37	546	197	202	27	755	155	1301	352
11:00		167	28			186	22				
11:15		153	24			197	17				
11:30		177	24			186	15				
11:45		203	11	700	87	201	13	770	67	1470	154
Total		3261	7023	3261	7023	4220	6840	4220	6840	7481	13863
Combined Total		10284		10284		11060		11060		21344	
AM Peak	-	11:00	-	-	-	07:30	-	-	-	-	-
Vol.	-	700	-	-	-	840	-	-	-	-	-
P.H.F.	-	0.862	-	-	-	0.946	-	-	-	-	-
PM Peak	-	-	04:45	-	-	-	00:30	-	-	-	-
Vol.	-	-	867	-	-	-	996	-	-	-	-
P.H.F.	-	-	0.860	-	-	-	0.902	-	-	-	-
Percentage		31.7%	68.3%			38.2%	61.8%				
ADT/AADT		ADT 21,344		AADT 21,344							

Appendix C

Intersection LOS Worksheets

Heritage at Dalia Ranch
1: SR-86 & Keystone Rd

Existing Conditions
Timing Plan: AM PEAK

Movement	EBL	EBT	EBR	WBL	WBT	WBR	NBL	NBT	NBR	SBL	SBT	SBR
Lane Configurations												
Traffic Volume (veh/h)	32	32	11	18	23	41	18	427	48	44	498	36
Future Volume (veh/h)	32	32	11	18	23	41	18	427	48	44	498	36
Initial Q (Qb), veh	0	0	0	0	0	0	0	0	0	0	0	0
Ped-Bike Adj(A_pbT)	1.00		1.00	1.00		1.00	1.00		1.00	1.00		1.00
Parking Bus, Adj	1.00	1.00	1.00	1.00	1.00	1.00	1.00	1.00	1.00	1.00	1.00	1.00
Work Zone On Approach		No			No			No			No	
Adj Sat Flow, veh/h/ln	1870	1870	1870	1870	1870	1870	1870	1870	1870	1870	1870	1870
Adj Flow Rate, veh/h	36	36	12	20	26	46	20	474	53	49	553	40
Peak Hour Factor	0.90	0.90	0.90	0.90	0.90	0.90	0.90	0.90	0.90	0.90	0.90	0.90
Percent Heavy Veh, %	2	2	2	2	2	2	2	2	2	2	2	2
Cap, veh/h	262	109	31	192	73	109	46	989	441	101	1098	490
Arrive On Green	0.13	0.13	0.13	0.13	0.13	0.13	0.03	0.28	0.28	0.06	0.31	0.31
Sat Flow, veh/h	598	822	237	272	551	822	1781	3554	1585	1781	3554	1585
Grp Volume(v), veh/h	84	0	0	92	0	0	20	474	53	49	553	40
Grp Sat Flow(s),veh/h/ln	1657	0	0	1645	0	0	1781	1777	1585	1781	1777	1585
Q Serve(g_s), s	0.0	0.0	0.0	0.2	0.0	0.0	0.3	3.1	0.7	0.8	3.6	0.5
Cycle Q Clear(g_c), s	1.2	0.0	0.0	1.4	0.0	0.0	0.3	3.1	0.7	0.8	3.6	0.5
Prop In Lane	0.43		0.14	0.22		0.50	1.00		1.00	1.00		1.00
Lane Grp Cap(c), veh/h	403	0	0	374	0	0	46	989	441	101	1098	490
V/C Ratio(X)	0.21	0.00	0.00	0.25	0.00	0.00	0.44	0.48	0.12	0.49	0.50	0.08
Avail Cap(c_a), veh/h	1191	0	0	1182	0	0	316	2271	1013	316	2271	1013
HCM Platoon Ratio	1.00	1.00	1.00	1.00	1.00	1.00	1.00	1.00	1.00	1.00	1.00	1.00
Upstream Filter(l)	1.00	0.00	0.00	1.00	0.00	0.00	1.00	1.00	1.00	1.00	1.00	1.00
Uniform Delay (d), s/veh	11.1	0.0	0.0	11.2	0.0	0.0	13.5	8.5	7.6	12.9	8.0	6.9
Incr Delay (d2), s/veh	0.3	0.0	0.0	0.3	0.0	0.0	6.4	0.4	0.1	3.6	0.4	0.1
Initial Q Delay(d3),s/veh	0.0	0.0	0.0	0.0	0.0	0.0	0.0	0.0	0.0	0.0	0.0	0.0
%ile BackOfQ(50%),veh/ln	0.4	0.0	0.0	0.4	0.0	0.0	0.2	0.8	0.2	0.3	0.9	0.1
Unsig. Movement Delay, s/veh												
LnGrp Delay(d),s/veh	11.4	0.0	0.0	11.5	0.0	0.0	19.9	8.8	7.7	16.5	8.3	7.0
LnGrp LOS	B	A	A	B	A	A	B	A	A	B	A	A
Approach Vol, veh/h		84			92			547			642	
Approach Delay, s/veh		11.4			11.5			9.1			8.9	
Approach LOS		B			B			A			A	
Timer - Assigned Phs	1	2		4	5	6		8				
Phs Duration (G+Y+Rc), s	6.6	12.8		8.7	5.7	13.7		8.7				
Change Period (Y+Rc), s	5.0	5.0		5.0	5.0	5.0		5.0				
Max Green Setting (Gmax), s	5.0	18.0		18.0	5.0	18.0		18.0				
Max Q Clear Time (g_c+I1), s	2.8	5.1		3.2	2.3	5.6		3.4				
Green Ext Time (p_c), s	0.0	2.7		0.3	0.0	3.1		0.3				
Intersection Summary												
HCM 6th Ctrl Delay				9.3								
HCM 6th LOS				A								

Heritage at Dalia Ranch
2: SR-86 & Larson Rd

Existing Conditions
Timing Plan: AM PEAK

Intersection												
Int Delay, s/veh	0.6											
Movement	EBL	EBT	EBR	WBL	WBT	WBR	NBL	NBT	NBR	SBL	SBT	SBR
Lane Configurations		↕			↕		↕	↕		↕	↕	
Traffic Vol, veh/h	19	3	2	1	2	5	0	492	1	1	503	7
Future Vol, veh/h	19	3	2	1	2	5	0	492	1	1	503	7
Conflicting Peds, #/hr	0	0	0	0	0	0	0	0	0	0	0	0
Sign Control	Stop	Stop	Stop	Stop	Stop	Stop	Free	Free	Free	Free	Free	Free
RT Channelized	-	-	None	-	-	None	-	-	None	-	-	None
Storage Length	-	-	-	-	-	-	50	-	-	50	-	-
Veh in Median Storage, #	-	0	-	-	0	-	-	0	-	-	0	-
Grade, %	-	0	-	-	0	-	-	0	-	-	0	-
Peak Hour Factor	94	94	94	94	94	94	94	94	94	94	94	94
Heavy Vehicles, %	2	2	2	2	2	2	2	2	2	2	2	2
Mvmt Flow	20	3	2	1	2	5	0	523	1	1	535	7

Major/Minor	Minor2		Minor1			Major1			Major2			
Conflicting Flow All	804	1065	271	795	1068	262	542	0	0	524	0	0
Stage 1	541	541	-	524	524	-	-	-	-	-	-	-
Stage 2	263	524	-	271	544	-	-	-	-	-	-	-
Critical Hdwy	7.54	6.54	6.94	7.54	6.54	6.94	4.14	-	-	4.14	-	-
Critical Hdwy Stg 1	6.54	5.54	-	6.54	5.54	-	-	-	-	-	-	-
Critical Hdwy Stg 2	6.54	5.54	-	6.54	5.54	-	-	-	-	-	-	-
Follow-up Hdwy	3.52	4.02	3.32	3.52	4.02	3.32	2.22	-	-	2.22	-	-
Pot Cap-1 Maneuver	274	221	727	278	220	737	1023	-	-	1039	-	-
Stage 1	493	519	-	504	528	-	-	-	-	-	-	-
Stage 2	719	528	-	712	517	-	-	-	-	-	-	-
Platoon blocked, %								-	-	-	-	-
Mov Cap-1 Maneuver	270	221	727	274	220	737	1023	-	-	1039	-	-
Mov Cap-2 Maneuver	270	221	-	274	220	-	-	-	-	-	-	-
Stage 1	493	518	-	504	528	-	-	-	-	-	-	-
Stage 2	711	528	-	705	516	-	-	-	-	-	-	-

Approach	EB	WB	NB	SB
HCM Control Delay, s	19.3	14	0	0
HCM LOS	C	B		

Minor Lane/Major Mvmt	NBL	NBT	NBR	EBLn1WBLn1	SBL	SBT	SBR
Capacity (veh/h)	1023	-	-	277	410	1039	-
HCM Lane V/C Ratio	-	-	-	0.092	0.021	0.001	-
HCM Control Delay (s)	0	-	-	19.3	14	8.5	-
HCM Lane LOS	A	-	-	C	B	A	-
HCM 95th %tile Q(veh)	0	-	-	0.3	0.1	0	-

Intersection						
Int Delay, s/veh	1.5					
Movement	WBL	WBR	NBT	NBR	SBL	SBT
Lane Configurations	Y		↑↑		↑	↑↑
Traffic Vol, veh/h	57	22	471	40	19	486
Future Vol, veh/h	57	22	471	40	19	486
Conflicting Peds, #/hr	0	0	0	0	0	0
Sign Control	Stop	Stop	Free	Free	Free	Free
RT Channelized	-	None	-	None	-	None
Storage Length	0	-	-	-	140	-
Veh in Median Storage, #	0	-	0	-	-	0
Grade, %	0	-	0	-	-	0
Peak Hour Factor	91	91	91	91	91	91
Heavy Vehicles, %	2	2	2	2	2	2
Mvmt Flow	63	24	518	44	21	534

Major/Minor	Minor1	Major1	Major2		
Conflicting Flow All	849	281	0	0	562
Stage 1	540	-	-	-	-
Stage 2	309	-	-	-	-
Critical Hdwy	6.84	6.94	-	-	4.14
Critical Hdwy Stg 1	5.84	-	-	-	-
Critical Hdwy Stg 2	5.84	-	-	-	-
Follow-up Hdwy	3.52	3.32	-	-	2.22
Pot Cap-1 Maneuver	300	716	-	-	1005
Stage 1	548	-	-	-	-
Stage 2	718	-	-	-	-
Platoon blocked, %			-	-	-
Mov Cap-1 Maneuver	294	716	-	-	1005
Mov Cap-2 Maneuver	294	-	-	-	-
Stage 1	548	-	-	-	-
Stage 2	703	-	-	-	-

Approach	WB	NB	SB
HCM Control Delay, s	18.5	0	0.3
HCM LOS	C		

Minor Lane/Major Mvmt	NBT	NBRWBLn1	SBL	SBT
Capacity (veh/h)	-	-	352	1005
HCM Lane V/C Ratio	-	-	0.247	0.021
HCM Control Delay (s)	-	-	18.5	8.7
HCM Lane LOS	-	-	C	A
HCM 95th %tile Q(veh)	-	-	1	0.1

Heritage at Dalia Ranch
4: Imperial Ave & Neckel Rd

Existing Conditions
Timing Plan: AM PEAK

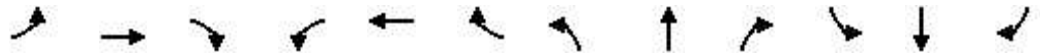

Movement	EBL	EBT	EBR	WBL	WBT	WBR	NBL	NBT	NBR	SBL	SBT	SBR
Lane Configurations		↕			↕		↕	↕		↕	↕	
Traffic Volume (veh/h)	33	42	12	138	62	54	8	430	63	14	497	30
Future Volume (veh/h)	33	42	12	138	62	54	8	430	63	14	497	30
Initial Q (Qb), veh	0	0	0	0	0	0	0	0	0	0	0	0
Ped-Bike Adj(A_pbT)	1.00		1.00	1.00		1.00	1.00		1.00	1.00		1.00
Parking Bus, Adj	1.00	1.00	1.00	1.00	1.00	1.00	1.00	1.00	1.00	1.00	1.00	1.00
Work Zone On Approach		No			No			No			No	
Adj Sat Flow, veh/h/ln	1870	1870	1870	1870	1870	1870	1870	1870	1870	1870	1870	1870
Adj Flow Rate, veh/h	36	46	13	152	68	59	9	473	69	15	546	33
Peak Hour Factor	0.91	0.91	0.91	0.91	0.91	0.91	0.91	0.91	0.91	0.91	0.91	0.91
Percent Heavy Veh, %	2	2	2	2	2	2	2	2	2	2	2	2
Cap, veh/h	53	67	19	203	91	79	21	749	109	34	844	51
Arrive On Green	0.08	0.08	0.08	0.21	0.21	0.21	0.01	0.24	0.24	0.02	0.25	0.25
Sat Flow, veh/h	679	868	245	957	428	371	1781	3114	452	1781	3405	205
Grp Volume(v), veh/h	95	0	0	279	0	0	9	269	273	15	284	295
Grp Sat Flow(s),veh/h/ln	1792	0	0	1756	0	0	1781	1777	1789	1781	1777	1833
Q Serve(g_s), s	2.3	0.0	0.0	6.6	0.0	0.0	0.2	6.0	6.1	0.4	6.4	6.4
Cycle Q Clear(g_c), s	2.3	0.0	0.0	6.6	0.0	0.0	0.2	6.0	6.1	0.4	6.4	6.4
Prop In Lane	0.38		0.14	0.54		0.21	1.00		0.25	1.00		0.11
Lane Grp Cap(c), veh/h	139	0	0	372	0	0	21	427	430	34	440	454
V/C Ratio(X)	0.68	0.00	0.00	0.75	0.00	0.00	0.43	0.63	0.63	0.44	0.65	0.65
Avail Cap(c_a), veh/h	727	0	0	713	0	0	201	761	766	201	761	785
HCM Platoon Ratio	1.00	1.00	1.00	1.00	1.00	1.00	1.00	1.00	1.00	1.00	1.00	1.00
Upstream Filter(l)	1.00	0.00	0.00	1.00	0.00	0.00	1.00	1.00	1.00	1.00	1.00	1.00
Uniform Delay (d), s/veh	19.9	0.0	0.0	16.4	0.0	0.0	21.8	15.1	15.1	21.5	14.9	15.0
Incr Delay (d2), s/veh	5.7	0.0	0.0	3.1	0.0	0.0	13.1	1.5	1.6	8.8	1.6	1.6
Initial Q Delay(d3),s/veh	0.0	0.0	0.0	0.0	0.0	0.0	0.0	0.0	0.0	0.0	0.0	0.0
%ile BackOfQ(50%),veh/ln	1.1	0.0	0.0	2.6	0.0	0.0	0.2	2.2	2.3	0.2	2.4	2.4
Unsig. Movement Delay, s/veh												
LnGrp Delay(d),s/veh	25.7	0.0	0.0	19.4	0.0	0.0	34.9	16.6	16.6	30.3	16.5	16.5
LnGrp LOS	C	A	A	B	A	A	C	B	B	C	B	B
Approach Vol, veh/h		95			279			551			594	
Approach Delay, s/veh		25.7			19.4			16.9			16.9	
Approach LOS		C			B			B			B	
Timer - Assigned Phs	1	2		4	5	6		8				
Phs Duration (G+Y+Rc), s	5.8	15.7		8.4	5.5	16.0		14.4				
Change Period (Y+Rc), s	5.0	5.0		5.0	5.0	5.0		5.0				
Max Green Setting (Gmax), s	5.0	19.0		18.0	5.0	19.0		18.0				
Max Q Clear Time (g_c+I1), s	2.4	8.1		4.3	2.2	8.4		8.6				
Green Ext Time (p_c), s	0.0	2.5		0.3	0.0	2.6		1.1				
Intersection Summary												
HCM 6th Ctrl Delay				17.9								
HCM 6th LOS				B								

Heritage at Dalia Ranch
5: La Brucherie Rd & Neckel Rd

Existing Conditions
Timing Plan: AM PEAK

Intersection												
Int Delay, s/veh	7.6											
Movement	EBL	EBT	EBR	WBL	WBT	WBR	NBL	NBT	NBR	SBL	SBT	SBR
Lane Configurations		↕			↕			↕			↕	
Traffic Vol, veh/h	4	40	22	58	43	0	7	6	41	1	2	1
Future Vol, veh/h	4	40	22	58	43	0	7	6	41	1	2	1
Conflicting Peds, #/hr	0	0	0	0	0	0	0	0	0	0	0	0
Sign Control	Stop	Stop	Stop	Stop	Stop	Stop	Free	Free	Free	Free	Free	Free
RT Channelized	-	-	None	-	-	None	-	-	None	-	-	None
Storage Length	-	-	-	-	-	-	-	-	-	-	-	-
Veh in Median Storage, #	-	0	-	-	0	-	-	0	-	-	0	-
Grade, %	-	0	-	-	0	-	-	0	-	-	0	-
Peak Hour Factor	79	79	79	79	79	79	79	79	79	79	79	79
Heavy Vehicles, %	2	2	2	2	2	2	2	2	2	2	2	2
Mvmt Flow	5	51	28	73	54	0	9	8	52	1	3	1

Major/Minor	Minor2		Minor1		Major1			Major2				
Conflicting Flow All	85	84	4	97	58	34	4	0	0	60	0	0
Stage 1	6	6	-	52	52	-	-	-	-	-	-	-
Stage 2	79	78	-	45	6	-	-	-	-	-	-	-
Critical Hdwy	7.12	6.52	6.22	7.12	6.52	6.22	4.12	-	-	4.12	-	-
Critical Hdwy Stg 1	6.12	5.52	-	6.12	5.52	-	-	-	-	-	-	-
Critical Hdwy Stg 2	6.12	5.52	-	6.12	5.52	-	-	-	-	-	-	-
Follow-up Hdwy	3.518	4.018	3.318	3.518	4.018	3.318	2.218	-	-	2.218	-	-
Pot Cap-1 Maneuver	901	806	1080	885	833	1039	1618	-	-	1544	-	-
Stage 1	1016	891	-	961	852	-	-	-	-	-	-	-
Stage 2	930	830	-	969	891	-	-	-	-	-	-	-
Platoon blocked, %								-	-	-	-	-
Mov Cap-1 Maneuver	851	800	1080	816	827	1039	1618	-	-	1544	-	-
Mov Cap-2 Maneuver	851	800	-	816	827	-	-	-	-	-	-	-
Stage 1	1010	890	-	955	847	-	-	-	-	-	-	-
Stage 2	865	825	-	889	890	-	-	-	-	-	-	-

Approach	EB		WB		NB		SB	
HCM Control Delay, s	9.5		10.2		0.9		1.8	
HCM LOS	A		B					

Minor Lane/Major Mvmt	NBL	NBT	NBR	EBLn1	WBLn1	SBL	SBT	SBR
Capacity (veh/h)	1618	-	-	879	821	1544	-	-
HCM Lane V/C Ratio	0.005	-	-	0.095	0.156	0.001	-	-
HCM Control Delay (s)	7.2	0	-	9.5	10.2	7.3	0	-
HCM Lane LOS	A	A	-	A	B	A	A	-
HCM 95th %tile Q(veh)	0	-	-	0.3	0.6	0	-	-

Heritage at Dalia Ranch
6: Imperial Ave & Worthington Rd/Barioni Blvd

Existing Conditions
Timing Plan: AM PEAK

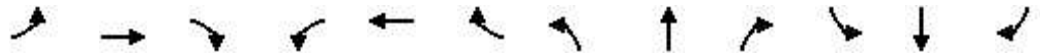

Movement	EBL	EBT	EBR	WBL	WBT	WBR	NBL	NBT	NBR	SBL	SBT	SBR
Lane Configurations		↕	↗		↕	↗	↗	↕↗		↗	↕↗	
Traffic Volume (veh/h)	68	132	206	53	128	75	90	452	49	38	613	54
Future Volume (veh/h)	68	132	206	53	128	75	90	452	49	38	613	54
Initial Q (Qb), veh	0	0	0	0	0	0	0	0	0	0	0	0
Ped-Bike Adj(A_pbT)	1.00		1.00	1.00		1.00	1.00		1.00	1.00		1.00
Parking Bus, Adj	1.00	1.00	1.00	1.00	1.00	1.00	1.00	1.00	1.00	1.00	1.00	1.00
Work Zone On Approach		No			No			No			No	
Adj Sat Flow, veh/h/ln	1870	1870	1870	1870	1870	1870	1870	1870	1870	1870	1870	1870
Adj Flow Rate, veh/h	76	148	231	60	144	84	101	508	55	43	689	61
Peak Hour Factor	0.89	0.89	0.89	0.89	0.89	0.89	0.89	0.89	0.89	0.89	0.89	0.89
Percent Heavy Veh, %	2	2	2	2	2	2	2	2	2	2	2	2
Cap, veh/h	119	232	303	82	198	241	129	941	102	75	860	76
Arrive On Green	0.19	0.19	0.19	0.15	0.15	0.15	0.07	0.29	0.29	0.04	0.26	0.26
Sat Flow, veh/h	624	1215	1585	542	1301	1585	1781	3235	349	1781	3302	292
Grp Volume(v), veh/h	224	0	231	204	0	84	101	278	285	43	370	380
Grp Sat Flow(s),veh/h/ln	1839	0	1585	1843	0	1585	1781	1777	1808	1781	1777	1818
Q Serve(g_s), s	6.9	0.0	8.5	6.5	0.0	2.9	3.4	8.1	8.2	1.5	12.0	12.1
Cycle Q Clear(g_c), s	6.9	0.0	8.5	6.5	0.0	2.9	3.4	8.1	8.2	1.5	12.0	12.1
Prop In Lane	0.34		1.00	0.29		1.00	1.00		0.19	1.00		0.16
Lane Grp Cap(c), veh/h	352	0	303	280	0	241	129	517	526	75	463	474
V/C Ratio(X)	0.64	0.00	0.76	0.73	0.00	0.35	0.78	0.54	0.54	0.57	0.80	0.80
Avail Cap(c_a), veh/h	536	0	462	537	0	462	144	546	556	144	546	559
HCM Platoon Ratio	1.00	1.00	1.00	1.00	1.00	1.00	1.00	1.00	1.00	1.00	1.00	1.00
Upstream Filter(I)	1.00	0.00	1.00	1.00	0.00	1.00	1.00	1.00	1.00	1.00	1.00	1.00
Uniform Delay (d), s/veh	23.0	0.0	23.7	25.0	0.0	23.5	28.2	18.4	18.4	29.0	21.3	21.4
Incr Delay (d2), s/veh	1.9	0.0	4.0	3.6	0.0	0.9	21.7	0.9	0.9	6.7	7.2	7.1
Initial Q Delay(d3),s/veh	0.0	0.0	0.0	0.0	0.0	0.0	0.0	0.0	0.0	0.0	0.0	0.0
%ile BackOfQ(50%),veh/ln	3.0	0.0	3.3	3.0	0.0	1.1	2.2	3.2	3.3	0.7	5.5	5.6
Unsig. Movement Delay, s/veh												
LnGrp Delay(d),s/veh	24.9	0.0	27.6	28.6	0.0	24.3	49.9	19.4	19.4	35.7	28.5	28.4
LnGrp LOS	C	A	C	C	A	C	D	B	B	D	C	C
Approach Vol, veh/h		455			288			664			793	
Approach Delay, s/veh		26.3			27.3			24.0			28.9	
Approach LOS		C			C			C			C	
Timer - Assigned Phs	1	2		4	5	6		8				
Phs Duration (G+Y+Rc), s	7.6	23.0		16.8	9.5	21.1		14.4				
Change Period (Y+Rc), s	5.0	5.0		5.0	5.0	5.0		5.0				
Max Green Setting (Gmax), s	5.0	19.0		18.0	5.0	19.0		18.0				
Max Q Clear Time (g_c+I1), s	3.5	10.2		10.5	5.4	14.1		8.5				
Green Ext Time (p_c), s	0.0	2.3		1.3	0.0	2.0		1.0				
Intersection Summary												
HCM 6th Ctrl Delay			26.7									
HCM 6th LOS			C									

Heritage at Dalia Ranch
7: La Brucherie Rd & Worthington Rd

Existing Conditions
Timing Plan: AM PEAK

Intersection												
Intersection Delay, s/veh	24.2											
Intersection LOS	C											

Movement	EBL	EBT	EBR	WBL	WBT	WBR	NBL	NBT	NBR	SBL	SBT	SBR
Lane Configurations		↔	↔		↔	↔		↔			↔	
Traffic Vol, veh/h	59	379	116	11	293	75	0	0	1	103	30	62
Future Vol, veh/h	59	379	116	11	293	75	0	0	1	103	30	62
Peak Hour Factor	0.83	0.83	0.83	0.83	0.83	0.83	0.83	0.83	0.83	0.83	0.83	0.83
Heavy Vehicles, %	2	2	2	2	2	2	2	2	2	2	2	2
Mvmt Flow	71	457	140	13	353	90	0	0	1	124	36	75
Number of Lanes	0	1	1	0	1	1	0	1	0	0	1	0

Approach	EB	WB	NB	SB
Opposing Approach	WB	EB	SB	NB
Opposing Lanes	2	2	1	1
Conflicting Approach Left	SB	NB	EB	WB
Conflicting Lanes Left	1	1	2	2
Conflicting Approach Right	NB	SB	WB	EB
Conflicting Lanes Right	1	1	2	2
HCM Control Delay	32.4	17.3	9.9	14.2
HCM LOS	D	C	A	B

Lane	NBLn1	EBLn1	EBLn2	WBLn1	WBLn2	SBLn1
Vol Left, %	0%	13%	0%	4%	0%	53%
Vol Thru, %	0%	87%	0%	96%	0%	15%
Vol Right, %	100%	0%	100%	0%	100%	32%
Sign Control	Stop	Stop	Stop	Stop	Stop	Stop
Traffic Vol by Lane	1	438	116	304	75	195
LT Vol	0	59	0	11	0	103
Through Vol	0	379	0	293	0	30
RT Vol	1	0	116	0	75	62
Lane Flow Rate	1	528	140	366	90	235
Geometry Grp	2	7	7	7	7	2
Degree of Util (X)	0.002	0.885	0.204	0.635	0.138	0.421
Departure Headway (Hd)	6.89	6.037	5.259	6.241	5.51	6.454
Convergence, Y/N	Yes	Yes	Yes	Yes	Yes	Yes
Cap	523	602	681	579	648	557
Service Time	4.89	3.789	3.009	3.999	3.268	4.518
HCM Lane V/C Ratio	0.002	0.877	0.206	0.632	0.139	0.422
HCM Control Delay	9.9	38.5	9.4	19.3	9.2	14.2
HCM Lane LOS	A	E	A	C	A	B
HCM 95th-tile Q	0	10.4	0.8	4.5	0.5	2.1

Heritage at Dalia Ranch
8: Imperial Ave & Aten Rd

Existing Conditions
Timing Plan: AM PEAK





















Movement	EBL	EBT	EBR	WBL	WBT	WBR	NBL	NBT	NBR	SBL	SBT	SBR
Lane Configurations												
Traffic Volume (veh/h)	181	328	61	127	291	137	59	334	65	138	652	365
Future Volume (veh/h)	181	328	61	127	291	137	59	334	65	138	652	365
Initial Q (Qb), veh	0	0	0	0	0	0	0	0	0	0	0	0
Ped-Bike Adj(A_pbT)	1.00		1.00	1.00		1.00	1.00		1.00	1.00		1.00
Parking Bus, Adj	1.00	1.00	1.00	1.00	1.00	1.00	1.00	1.00	1.00	1.00	1.00	1.00
Work Zone On Approach		No			No			No			No	
Adj Sat Flow, veh/h/ln	1870	1870	1870	1870	1870	1870	1870	1870	1870	1870	1870	1870
Adj Flow Rate, veh/h	210	381	71	148	338	159	69	388	76	160	758	424
Peak Hour Factor	0.86	0.86	0.86	0.86	0.86	0.86	0.86	0.86	0.86	0.86	0.86	0.86
Percent Heavy Veh, %	2	2	2	2	2	2	2	2	2	2	2	2
Cap, veh/h	253	690	127	187	456	210	96	901	402	199	1106	493
Arrive On Green	0.14	0.23	0.23	0.10	0.19	0.19	0.05	0.25	0.25	0.11	0.31	0.31
Sat Flow, veh/h	1781	2995	553	1781	2361	1090	1781	3554	1585	1781	3554	1585
Grp Volume(v), veh/h	210	225	227	148	253	244	69	388	76	160	758	424
Grp Sat Flow(s),veh/h/ln	1781	1777	1771	1781	1777	1674	1781	1777	1585	1781	1777	1585
Q Serve(g_s), s	7.7	7.4	7.6	5.4	8.9	9.2	2.5	6.1	2.5	5.9	12.5	16.8
Cycle Q Clear(g_c), s	7.7	7.4	7.6	5.4	8.9	9.2	2.5	6.1	2.5	5.9	12.5	16.8
Prop In Lane	1.00		0.31	1.00		0.65	1.00		1.00	1.00		1.00
Lane Grp Cap(c), veh/h	253	409	408	187	343	323	96	901	402	199	1106	493
V/C Ratio(X)	0.83	0.55	0.56	0.79	0.74	0.76	0.72	0.43	0.19	0.80	0.69	0.86
Avail Cap(c_a), veh/h	267	506	504	240	479	452	133	1012	451	214	1171	522
HCM Platoon Ratio	1.00	1.00	1.00	1.00	1.00	1.00	1.00	1.00	1.00	1.00	1.00	1.00
Upstream Filter(I)	1.00	1.00	1.00	1.00	1.00	1.00	1.00	1.00	1.00	1.00	1.00	1.00
Uniform Delay (d), s/veh	27.8	22.6	22.7	29.2	25.3	25.4	31.1	20.9	19.5	28.9	20.1	21.6
Incr Delay (d2), s/veh	18.6	1.1	1.2	12.9	3.7	4.6	10.6	0.3	0.2	18.6	1.6	13.1
Initial Q Delay(d3),s/veh	0.0	0.0	0.0	0.0	0.0	0.0	0.0	0.0	0.0	0.0	0.0	0.0
%ile BackOfQ(50%),veh/ln	4.4	3.1	3.1	2.9	3.9	3.9	1.3	2.4	0.9	3.4	5.0	7.5
Unsig. Movement Delay, s/veh												
LnGrp Delay(d),s/veh	46.5	23.8	23.9	42.1	29.0	30.1	41.7	21.2	19.8	47.6	21.7	34.7
LnGrp LOS	D	C	C	D	C	C	D	C	B	D	C	C
Approach Vol, veh/h		662			645			533			1342	
Approach Delay, s/veh		31.0			32.4			23.6			28.9	
Approach LOS		C			C			C			C	
Timer - Assigned Phs	1	2	3	4	5	6	7	8				
Phs Duration (G+Y+Rc), s	2.5	21.9	12.0	20.4	8.6	25.8	14.5	17.9				
Change Period (Y+Rc), s	5.0	5.0	5.0	5.0	5.0	5.0	5.0	5.0				
Max Green Setting (Gmax), s	19.0	19.0	9.0	19.0	5.0	22.0	10.0	18.0				
Max Q Clear Time (g_c+1), s	8.1	8.1	7.4	9.6	4.5	18.8	9.7	11.2				
Green Ext Time (p_c), s	0.0	2.1	0.1	1.8	0.0	2.0	0.0	1.7				

Intersection Summary

HCM 6th Ctrl Delay				29.2								
HCM 6th LOS				C								

Heritage at Dalia Ranch
1: SR-86 & Keystone Rd

Existing Conditions
Timing Plan: PM PEAK

												
Movement	EBL	EBT	EBR	WBL	WBT	WBR	NBL	NBT	NBR	SBL	SBT	SBR
Lane Configurations												
Traffic Volume (veh/h)	40	12	19	32	26	36	10	509	25	51	527	33
Future Volume (veh/h)	40	12	19	32	26	36	10	509	25	51	527	33
Initial Q (Qb), veh	0	0	0	0	0	0	0	0	0	0	0	0
Ped-Bike Adj(A_pbT)	1.00		1.00	1.00		1.00	1.00		1.00	1.00		1.00
Parking Bus, Adj	1.00	1.00	1.00	1.00	1.00	1.00	1.00	1.00	1.00	1.00	1.00	1.00
Work Zone On Approach		No			No			No			No	
Adj Sat Flow, veh/h/ln	1870	1870	1870	1870	1870	1870	1870	1870	1870	1870	1870	1870
Adj Flow Rate, veh/h	45	13	21	36	29	40	11	572	28	57	592	37
Peak Hour Factor	0.89	0.89	0.89	0.89	0.89	0.89	0.89	0.89	0.89	0.89	0.89	0.89
Percent Heavy Veh, %	2	2	2	2	2	2	2	2	2	2	2	2
Cap, veh/h	290	50	56	220	71	81	26	1111	495	112	1282	572
Arrive On Green	0.13	0.13	0.13	0.13	0.13	0.13	0.01	0.31	0.31	0.06	0.36	0.36
Sat Flow, veh/h	798	386	429	466	547	624	1781	3554	1585	1781	3554	1585
Grp Volume(v), veh/h	79	0	0	105	0	0	11	572	28	57	592	37
Grp Sat Flow(s),veh/h/ln	1613	0	0	1638	0	0	1781	1777	1585	1781	1777	1585
Q Serve(g_s), s	0.0	0.0	0.0	0.5	0.0	0.0	0.2	4.0	0.4	0.9	3.9	0.5
Cycle Q Clear(g_c), s	1.2	0.0	0.0	1.7	0.0	0.0	0.2	4.0	0.4	0.9	3.9	0.5
Prop In Lane	0.57		0.27	0.34		0.38	1.00		1.00	1.00		1.00
Lane Grp Cap(c), veh/h	396	0	0	372	0	0	26	1111	495	112	1282	572
V/C Ratio(X)	0.20	0.00	0.00	0.28	0.00	0.00	0.42	0.51	0.06	0.51	0.46	0.06
Avail Cap(c_a), veh/h	1074	0	0	1100	0	0	294	2461	1098	352	2578	1150
HCM Platoon Ratio	1.00	1.00	1.00	1.00	1.00	1.00	1.00	1.00	1.00	1.00	1.00	1.00
Upstream Filter(l)	1.00	0.00	0.00	1.00	0.00	0.00	1.00	1.00	1.00	1.00	1.00	1.00
Uniform Delay (d), s/veh	12.0	0.0	0.0	12.2	0.0	0.0	14.8	8.5	7.3	13.8	7.4	6.3
Incr Delay (d2), s/veh	0.2	0.0	0.0	0.4	0.0	0.0	10.6	0.4	0.0	3.5	0.3	0.0
Initial Q Delay(d3),s/veh	0.0	0.0	0.0	0.0	0.0	0.0	0.0	0.0	0.0	0.0	0.0	0.0
%ile BackOfQ(50%),veh/ln	0.4	0.0	0.0	0.5	0.0	0.0	0.1	1.1	0.1	0.4	0.9	0.1
Unsig. Movement Delay, s/veh												
LnGrp Delay(d),s/veh	12.3	0.0	0.0	12.6	0.0	0.0	25.4	8.9	7.3	17.3	7.7	6.4
LnGrp LOS	B	A	A	B	A	A	C	A	A	B	A	A
Approach Vol, veh/h		79			105			611			686	
Approach Delay, s/veh		12.3			12.6			9.1			8.4	
Approach LOS		B			B			A			A	
Timer - Assigned Phs	1	2		4	5	6		8				
Phs Duration (G+Y+Rc), s	6.9	14.5		8.9	5.4	15.9		8.9				
Change Period (Y+Rc), s	5.0	5.0		5.0	5.0	5.0		5.0				
Max Green Setting (Gmax), s	6.0	21.0		18.0	5.0	22.0		18.0				
Max Q Clear Time (g_c+I1), s	2.9	6.0		3.2	2.2	5.9		3.7				
Green Ext Time (p_c), s	0.0	3.5		0.3	0.0	3.8		0.4				
Intersection Summary												
HCM 6th Ctrl Delay				9.2								
HCM 6th LOS				A								

Intersection												
Int Delay, s/veh	0.4											
Movement	EBL	EBT	EBR	WBL	WBT	WBR	NBL	NBT	NBR	SBL	SBT	SBR
Lane Configurations		↕			↕		↕	↕		↕	↕	
Traffic Vol, veh/h	6	4	0	7	0	5	1	546	7	6	562	17
Future Vol, veh/h	6	4	0	7	0	5	1	546	7	6	562	17
Conflicting Peds, #/hr	0	0	0	0	0	0	0	0	0	0	0	0
Sign Control	Stop	Stop	Stop	Stop	Stop	Stop	Free	Free	Free	Free	Free	Free
RT Channelized	-	-	None	-	-	None	-	-	None	-	-	None
Storage Length	-	-	-	-	-	-	50	-	-	50	-	-
Veh in Median Storage, #	-	0	-	-	0	-	-	0	-	-	0	-
Grade, %	-	0	-	-	0	-	-	0	-	-	0	-
Peak Hour Factor	92	92	92	92	92	92	92	92	92	92	92	92
Heavy Vehicles, %	2	2	2	2	2	2	2	2	2	2	2	2
Mvmt Flow	7	4	0	8	0	5	1	593	8	7	611	18

Major/Minor	Minor2		Minor1		Major1		Major2					
Conflicting Flow All	933	1237	315	921	1242	301	629	0	0	601	0	0
Stage 1	634	634	-	599	599	-	-	-	-	-	-	-
Stage 2	299	603	-	322	643	-	-	-	-	-	-	-
Critical Hdwy	7.54	6.54	6.94	7.54	6.54	6.94	4.14	-	-	4.14	-	-
Critical Hdwy Stg 1	6.54	5.54	-	6.54	5.54	-	-	-	-	-	-	-
Critical Hdwy Stg 2	6.54	5.54	-	6.54	5.54	-	-	-	-	-	-	-
Follow-up Hdwy	3.52	4.02	3.32	3.52	4.02	3.32	2.22	-	-	2.22	-	-
Pot Cap-1 Maneuver	221	175	681	225	173	695	949	-	-	972	-	-
Stage 1	434	471	-	455	489	-	-	-	-	-	-	-
Stage 2	685	487	-	664	467	-	-	-	-	-	-	-
Platoon blocked, %								-	-	-	-	-
Mov Cap-1 Maneuver	218	174	681	219	172	695	949	-	-	972	-	-
Mov Cap-2 Maneuver	218	174	-	219	172	-	-	-	-	-	-	-
Stage 1	434	468	-	455	489	-	-	-	-	-	-	-
Stage 2	679	487	-	653	464	-	-	-	-	-	-	-

Approach	EB		WB		NB		SB	
HCM Control Delay, s	24.2		17.3		0		0.1	
HCM LOS	C		C					

Minor Lane/Major Mvmt	NBL	NBT	NBR	EBLn1	WBLn1	SBL	SBT	SBR
Capacity (veh/h)	949	-	-	198	306	972	-	-
HCM Lane V/C Ratio	0.001	-	-	0.055	0.043	0.007	-	-
HCM Control Delay (s)	8.8	-	-	24.2	17.3	8.7	-	-
HCM Lane LOS	A	-	-	C	C	A	-	-
HCM 95th %tile Q(veh)	0	-	-	0.2	0.1	0	-	-

Intersection						
Int Delay, s/veh	0.7					
Movement	WBL	WBR	NBT	NBR	SBL	SBT
Lane Configurations	W		T		T	T
Traffic Vol, veh/h	19	10	547	29	29	527
Future Vol, veh/h	19	10	547	29	29	527
Conflicting Peds, #/hr	0	0	0	0	0	0
Sign Control	Stop	Stop	Free	Free	Free	Free
RT Channelized	-	None	-	None	-	None
Storage Length	0	-	-	-	140	-
Veh in Median Storage, #	0	-	0	-	-	0
Grade, %	0	-	0	-	-	0
Peak Hour Factor	91	91	91	91	91	91
Heavy Vehicles, %	2	2	2	2	2	2
Mvmt Flow	21	11	601	32	32	579

Major/Minor	Minor1	Major1	Major2		
Conflicting Flow All	971	317	0	0	633
Stage 1	617	-	-	-	-
Stage 2	354	-	-	-	-
Critical Hdwy	6.84	6.94	-	-	4.14
Critical Hdwy Stg 1	5.84	-	-	-	-
Critical Hdwy Stg 2	5.84	-	-	-	-
Follow-up Hdwy	3.52	3.32	-	-	2.22
Pot Cap-1 Maneuver	250	679	-	-	946
Stage 1	501	-	-	-	-
Stage 2	681	-	-	-	-
Platoon blocked, %					
Mov Cap-1 Maneuver	242	679	-	-	946
Mov Cap-2 Maneuver	242	-	-	-	-
Stage 1	501	-	-	-	-
Stage 2	658	-	-	-	-

Approach	WB	NB	SB
HCM Control Delay, s	17.9	0	0.5
HCM LOS	C		

Minor Lane/Major Mvmt	NBT	NBRWBLn1	SBL	SBT
Capacity (veh/h)	-	-	311	946
HCM Lane V/C Ratio	-	-	0.102	0.034
HCM Control Delay (s)	-	-	17.9	8.9
HCM Lane LOS	-	-	C	A
HCM 95th %tile Q(veh)	-	-	0.3	0.1

Heritage at Dalia Ranch
4: Imperial Ave & Neckel Rd

Existing Conditions
Timing Plan: PM PEAK

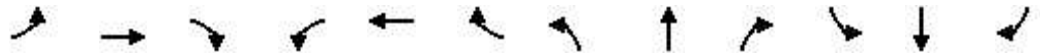

Movement	EBL	EBT	EBR	WBL	WBT	WBR	NBL	NBT	NBR	SBL	SBT	SBR
Lane Configurations		↕			↕		↕	↕		↕	↕	
Traffic Volume (veh/h)	12	25	4	80	19	45	11	540	81	28	482	27
Future Volume (veh/h)	12	25	4	80	19	45	11	540	81	28	482	27
Initial Q (Qb), veh	0	0	0	0	0	0	0	0	0	0	0	0
Ped-Bike Adj(A_pbT)	1.00		1.00	1.00		1.00	1.00		1.00	1.00		1.00
Parking Bus, Adj	1.00	1.00	1.00	1.00	1.00	1.00	1.00	1.00	1.00	1.00	1.00	1.00
Work Zone On Approach		No			No			No			No	
Adj Sat Flow, veh/h/ln	1870	1870	1870	1870	1870	1870	1870	1870	1870	1870	1870	1870
Adj Flow Rate, veh/h	13	27	4	87	21	49	12	587	88	30	524	29
Peak Hour Factor	0.92	0.92	0.92	0.92	0.92	0.92	0.92	0.92	0.92	0.92	0.92	0.92
Percent Heavy Veh, %	2	2	2	2	2	2	2	2	2	2	2	2
Cap, veh/h	26	54	8	121	29	68	28	905	135	63	1068	59
Arrive On Green	0.05	0.05	0.05	0.13	0.13	0.13	0.02	0.29	0.29	0.04	0.31	0.31
Sat Flow, veh/h	536	1113	165	956	231	539	1781	3100	464	1781	3424	189
Grp Volume(v), veh/h	44	0	0	157	0	0	12	336	339	30	271	282
Grp Sat Flow(s),veh/h/ln	1814	0	0	1726	0	0	1781	1777	1787	1781	1777	1836
Q Serve(g_s), s	1.0	0.0	0.0	3.5	0.0	0.0	0.3	6.6	6.7	0.7	5.0	5.0
Cycle Q Clear(g_c), s	1.0	0.0	0.0	3.5	0.0	0.0	0.3	6.6	6.7	0.7	5.0	5.0
Prop In Lane	0.30		0.09	0.55		0.31	1.00		0.26	1.00		0.10
Lane Grp Cap(c), veh/h	88	0	0	218	0	0	28	519	522	63	554	573
V/C Ratio(X)	0.50	0.00	0.00	0.72	0.00	0.00	0.43	0.65	0.65	0.48	0.49	0.49
Avail Cap(c_a), veh/h	813	0	0	773	0	0	222	840	845	222	840	869
HCM Platoon Ratio	1.00	1.00	1.00	1.00	1.00	1.00	1.00	1.00	1.00	1.00	1.00	1.00
Upstream Filter(l)	1.00	0.00	0.00	1.00	0.00	0.00	1.00	1.00	1.00	1.00	1.00	1.00
Uniform Delay (d), s/veh	18.6	0.0	0.0	16.9	0.0	0.0	19.6	12.4	12.4	19.0	11.2	11.2
Incr Delay (d2), s/veh	4.4	0.0	0.0	4.4	0.0	0.0	10.2	1.4	1.4	5.5	0.7	0.7
Initial Q Delay(d3),s/veh	0.0	0.0	0.0	0.0	0.0	0.0	0.0	0.0	0.0	0.0	0.0	0.0
%ile BackOfQ(50%),veh/ln	0.5	0.0	0.0	1.5	0.0	0.0	0.2	2.3	2.3	0.3	1.6	1.7
Unsig. Movement Delay, s/veh												
LnGrp Delay(d),s/veh	23.0	0.0	0.0	21.3	0.0	0.0	29.8	13.8	13.8	24.5	11.9	11.9
LnGrp LOS	C	A	A	C	A	A	C	B	B	C	B	B
Approach Vol, veh/h		44			157			687			583	
Approach Delay, s/veh		23.0			21.3			14.1			12.5	
Approach LOS		C			C			B			B	
Timer - Assigned Phs	1	2		4	5	6		8				
Phs Duration (G+Y+Rc), s	6.4	16.7		6.9	5.6	17.5		10.1				
Change Period (Y+Rc), s	5.0	5.0		5.0	5.0	5.0		5.0				
Max Green Setting (Gmax), s	5.0	19.0		18.0	5.0	19.0		18.0				
Max Q Clear Time (g_c+I1), s	2.7	8.7		3.0	2.3	7.0		5.5				
Green Ext Time (p_c), s	0.0	3.1		0.1	0.0	2.6		0.6				
Intersection Summary												
HCM 6th Ctrl Delay				14.5								
HCM 6th LOS				B								

Heritage at Dalia Ranch
5: La Brucherie Rd & Neckel Rd

Existing Conditions
Timing Plan: PM PEAK

Intersection												
Int Delay, s/veh	7.6											
Movement	EBL	EBT	EBR	WBL	WBT	WBR	NBL	NBT	NBR	SBL	SBT	SBR
Lane Configurations		↕			↕			↕			↕	
Traffic Vol, veh/h	2	37	8	22	43	1	5	6	10	0	5	7
Future Vol, veh/h	2	37	8	22	43	1	5	6	10	0	5	7
Conflicting Peds, #/hr	0	0	0	0	0	0	0	0	0	0	0	0
Sign Control	Stop	Stop	Stop	Stop	Stop	Stop	Free	Free	Free	Free	Free	Free
RT Channelized	-	-	None	-	-	None	-	-	None	-	-	None
Storage Length	-	-	-	-	-	-	-	-	-	-	-	-
Veh in Median Storage, #	-	0	-	-	0	-	-	0	-	-	0	-
Grade, %	-	0	-	-	0	-	-	0	-	-	0	-
Peak Hour Factor	79	79	79	79	79	79	79	79	79	79	79	79
Heavy Vehicles, %	2	2	2	2	2	2	2	2	2	2	2	2
Mvmt Flow	3	47	10	28	54	1	6	8	13	0	6	9

Major/Minor	Minor2		Minor1			Major1			Major2			
Conflicting Flow All	65	44	11	66	42	15	15	0	0	21	0	0
Stage 1	11	11	-	27	27	-	-	-	-	-	-	-
Stage 2	54	33	-	39	15	-	-	-	-	-	-	-
Critical Hdwy	7.12	6.52	6.22	7.12	6.52	6.22	4.12	-	-	4.12	-	-
Critical Hdwy Stg 1	6.12	5.52	-	6.12	5.52	-	-	-	-	-	-	-
Critical Hdwy Stg 2	6.12	5.52	-	6.12	5.52	-	-	-	-	-	-	-
Follow-up Hdwy	3.518	4.018	3.318	3.518	4.018	3.318	2.218	-	-	2.218	-	-
Pot Cap-1 Maneuver	929	848	1070	927	850	1065	1603	-	-	1595	-	-
Stage 1	1010	886	-	990	873	-	-	-	-	-	-	-
Stage 2	958	868	-	976	883	-	-	-	-	-	-	-
Platoon blocked, %								-	-	-	-	-
Mov Cap-1 Maneuver	880	845	1070	877	847	1065	1603	-	-	1595	-	-
Mov Cap-2 Maneuver	880	845	-	877	847	-	-	-	-	-	-	-
Stage 1	1006	886	-	986	870	-	-	-	-	-	-	-
Stage 2	893	865	-	916	883	-	-	-	-	-	-	-

Approach	EB		WB			NB			SB			
HCM Control Delay, s	9.4		9.6			1.7			0			
HCM LOS	A		A									

Minor Lane/Major Mvmt	NBL	NBT	NBR	EBLn1	WBLn1	SBL	SBT	SBR
Capacity (veh/h)	1603	-	-	878	859	1595	-	-
HCM Lane V/C Ratio	0.004	-	-	0.068	0.097	-	-	-
HCM Control Delay (s)	7.3	0	-	9.4	9.6	0	-	-
HCM Lane LOS	A	A	-	A	A	A	-	-
HCM 95th %tile Q(veh)	0	-	-	0.2	0.3	0	-	-

Heritage at Dalia Ranch
6: Imperial Ave & Worthington Rd/Barioni Blvd

Existing Conditions
Timing Plan: PM PEAK

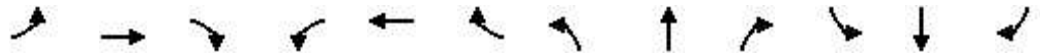

Movement	EBL	EBT	EBR	WBL	WBT	WBR	NBL	NBT	NBR	SBL	SBT	SBR
Lane Configurations		↕	↗		↕	↗	↗	↕↗		↗	↕↗	
Traffic Volume (veh/h)	47	72	102	53	109	50	109	648	14	26	577	61
Future Volume (veh/h)	47	72	102	53	109	50	109	648	14	26	577	61
Initial Q (Qb), veh	0	0	0	0	0	0	0	0	0	0	0	0
Ped-Bike Adj(A_pbT)	1.00		1.00	1.00		1.00	1.00		1.00	1.00		1.00
Parking Bus, Adj	1.00	1.00	1.00	1.00	1.00	1.00	1.00	1.00	1.00	1.00	1.00	1.00
Work Zone On Approach		No			No			No			No	
Adj Sat Flow, veh/h/ln	1870	1870	1870	1870	1870	1870	1870	1870	1870	1870	1870	1870
Adj Flow Rate, veh/h	52	79	112	58	120	55	120	712	15	29	634	67
Peak Hour Factor	0.91	0.91	0.91	0.91	0.91	0.91	0.91	0.91	0.91	0.91	0.91	0.91
Percent Heavy Veh, %	2	2	2	2	2	2	2	2	2	2	2	2
Cap, veh/h	87	131	188	85	176	225	154	1132	24	59	859	91
Arrive On Green	0.12	0.12	0.12	0.14	0.14	0.14	0.09	0.32	0.32	0.03	0.26	0.26
Sat Flow, veh/h	728	1106	1585	600	1241	1585	1781	3559	75	1781	3243	342
Grp Volume(v), veh/h	131	0	112	178	0	55	120	355	372	29	347	354
Grp Sat Flow(s),veh/h/ln	1834	0	1585	1840	0	1585	1781	1777	1857	1781	1777	1809
Q Serve(g_s), s	3.5	0.0	3.4	4.7	0.0	1.6	3.4	8.8	8.8	0.8	9.2	9.2
Cycle Q Clear(g_c), s	3.5	0.0	3.4	4.7	0.0	1.6	3.4	8.8	8.8	0.8	9.2	9.2
Prop In Lane	0.40		1.00	0.33		1.00	1.00		0.04	1.00		0.19
Lane Grp Cap(c), veh/h	218	0	188	261	0	225	154	565	591	59	470	479
V/C Ratio(X)	0.60	0.00	0.59	0.68	0.00	0.24	0.78	0.63	0.63	0.49	0.74	0.74
Avail Cap(c_a), veh/h	641	0	554	643	0	554	208	656	685	173	621	632
HCM Platoon Ratio	1.00	1.00	1.00	1.00	1.00	1.00	1.00	1.00	1.00	1.00	1.00	1.00
Upstream Filter(I)	1.00	0.00	1.00	1.00	0.00	1.00	1.00	1.00	1.00	1.00	1.00	1.00
Uniform Delay (d), s/veh	21.5	0.0	21.5	21.0	0.0	19.6	23.0	15.0	15.0	24.5	17.3	17.3
Incr Delay (d2), s/veh	2.6	0.0	3.0	3.1	0.0	0.6	12.5	1.5	1.4	6.3	3.2	3.2
Initial Q Delay(d3),s/veh	0.0	0.0	0.0	0.0	0.0	0.0	0.0	0.0	0.0	0.0	0.0	0.0
%ile BackOfQ(50%),veh/ln	1.5	0.0	1.3	2.1	0.0	0.6	1.8	3.3	3.4	0.4	3.7	3.8
Unsig. Movement Delay, s/veh												
LnGrp Delay(d),s/veh	24.2	0.0	24.5	24.1	0.0	20.2	35.6	16.5	16.4	30.8	20.5	20.5
LnGrp LOS	C	A	C	C	A	C	D	B	B	C	C	C
Approach Vol, veh/h		243			233			847			730	
Approach Delay, s/veh		24.3			23.2			19.2			20.9	
Approach LOS		C			C			B			C	
Timer - Assigned Phs	1	2		4	5	6		8				
Phs Duration (G+Y+Rc), s	6.7	21.4		11.1	9.4	18.6		12.3				
Change Period (Y+Rc), s	5.0	5.0		5.0	5.0	5.0		5.0				
Max Green Setting (Gmax), s	5.0	19.0		18.0	6.0	18.0		18.0				
Max Q Clear Time (g_c+I1), s	2.8	10.8		5.5	5.4	11.2		6.7				
Green Ext Time (p_c), s	0.0	2.9		0.8	0.0	2.4		0.8				
Intersection Summary												
HCM 6th Ctrl Delay				20.9								
HCM 6th LOS				C								

Heritage at Dalia Ranch
7: La Brucherie Rd & Worthington Rd

Existing Conditions
Timing Plan: PM PEAK

Intersection												
Intersection Delay, s/veh	10.4											
Intersection LOS	B											

Movement	EBL	EBT	EBR	WBL	WBT	WBR	NBL	NBT	NBR	SBL	SBT	SBR
Lane Configurations		↔	↔		↔	↔		↔			↔	
Traffic Vol, veh/h	25	182	32	26	209	33	1	0	0	36	5	23
Future Vol, veh/h	25	182	32	26	209	33	1	0	0	36	5	23
Peak Hour Factor	0.80	0.80	0.80	0.80	0.80	0.80	0.80	0.80	0.80	0.80	0.80	0.80
Heavy Vehicles, %	2	2	2	2	2	2	2	2	2	2	2	2
Mvmt Flow	31	228	40	33	261	41	1	0	0	45	6	29
Number of Lanes	0	1	1	0	1	1	0	1	0	0	1	0

Approach	EB	WB	NB	SB
Opposing Approach	WB	EB	SB	NB
Opposing Lanes	2	2	1	1
Conflicting Approach Left	SB	NB	EB	WB
Conflicting Lanes Left	1	1	2	2
Conflicting Approach Right	NB	SB	WB	EB
Conflicting Lanes Right	1	1	2	2
HCM Control Delay	10.3	10.8	8.8	9
HCM LOS	B	B	A	A

Lane	NBLn1	EBLn1	EBLn2	WBLn1	WBLn2	SBLn1
Vol Left, %	100%	12%	0%	11%	0%	56%
Vol Thru, %	0%	88%	0%	89%	0%	8%
Vol Right, %	0%	0%	100%	0%	100%	36%
Sign Control	Stop	Stop	Stop	Stop	Stop	Stop
Traffic Vol by Lane	1	207	32	235	33	64
LT Vol	1	25	0	26	0	36
Through Vol	0	182	0	209	0	5
RT Vol	0	0	32	0	33	23
Lane Flow Rate	1	259	40	294	41	80
Geometry Grp	2	7	7	7	7	2
Degree of Util (X)	0.002	0.366	0.048	0.412	0.049	0.117
Departure Headway (Hd)	5.73	5.09	4.326	5.055	4.296	5.281
Convergence, Y/N	Yes	Yes	Yes	Yes	Yes	Yes
Cap	622	706	827	711	832	677
Service Time	3.792	2.823	2.058	2.788	2.028	3.326
HCM Lane V/C Ratio	0.002	0.367	0.048	0.414	0.049	0.118
HCM Control Delay	8.8	10.8	7.3	11.3	7.3	9
HCM Lane LOS	A	B	A	B	A	A
HCM 95th-tile Q	0	1.7	0.2	2	0.2	0.4

Heritage at Dalia Ranch
8: Imperial Ave & Aten Rd

Existing Conditions
Timing Plan: PM PEAK



Movement	EBL	EBT	EBR	WBL	WBT	WBR	NBL	NBT	NBR	SBL	SBT	SBR
Lane Configurations	↖	↖		↖	↖		↖	↖	↖	↖	↖	↖
Traffic Volume (veh/h)	184	268	66	173	280	119	76	646	145	109	523	203
Future Volume (veh/h)	184	268	66	173	280	119	76	646	145	109	523	203
Initial Q (Qb), veh	0	0	0	0	0	0	0	0	0	0	0	0
Ped-Bike Adj(A_pbT)	1.00		1.00	1.00		1.00	1.00		1.00	1.00		1.00
Parking Bus, Adj	1.00	1.00	1.00	1.00	1.00	1.00	1.00	1.00	1.00	1.00	1.00	1.00
Work Zone On Approach		No			No			No			No	
Adj Sat Flow, veh/h/ln	1870	1870	1870	1870	1870	1870	1870	1870	1870	1870	1870	1870
Adj Flow Rate, veh/h	196	285	70	184	298	127	81	687	154	116	556	216
Peak Hour Factor	0.94	0.94	0.94	0.94	0.94	0.94	0.94	0.94	0.94	0.94	0.94	0.94
Percent Heavy Veh, %	2	2	2	2	2	2	2	2	2	2	2	2
Cap, veh/h	244	532	128	231	440	183	111	921	411	149	996	444
Arrive On Green	0.14	0.19	0.19	0.13	0.18	0.18	0.06	0.26	0.26	0.08	0.28	0.28
Sat Flow, veh/h	1781	2838	686	1781	2445	1019	1781	3554	1585	1781	3554	1585
Grp Volume(v), veh/h	196	177	178	184	215	210	81	687	154	116	556	216
Grp Sat Flow(s),veh/h/ln	1781	1777	1747	1781	1777	1687	1781	1777	1585	1781	1777	1585
Q Serve(g_s), s	6.3	5.3	5.4	5.9	6.6	6.9	2.6	10.4	4.7	3.8	7.8	6.7
Cycle Q Clear(g_c), s	6.3	5.3	5.4	5.9	6.6	6.9	2.6	10.4	4.7	3.8	7.8	6.7
Prop In Lane	1.00		0.39	1.00		0.60	1.00		1.00	1.00		1.00
Lane Grp Cap(c), veh/h	244	333	327	231	320	304	111	921	411	149	996	444
V/C Ratio(X)	0.80	0.53	0.55	0.80	0.67	0.69	0.73	0.75	0.37	0.78	0.56	0.49
Avail Cap(c_a), veh/h	333	544	535	333	544	516	182	1148	512	212	1209	539
HCM Platoon Ratio	1.00	1.00	1.00	1.00	1.00	1.00	1.00	1.00	1.00	1.00	1.00	1.00
Upstream Filter(I)	1.00	1.00	1.00	1.00	1.00	1.00	1.00	1.00	1.00	1.00	1.00	1.00
Uniform Delay (d), s/veh	24.6	21.6	21.6	24.8	22.5	22.6	27.1	20.0	17.9	26.4	18.1	17.6
Incr Delay (d2), s/veh	9.5	1.3	1.4	8.3	2.4	2.8	8.8	2.1	0.6	11.1	0.5	0.8
Initial Q Delay(d3),s/veh	0.0	0.0	0.0	0.0	0.0	0.0	0.0	0.0	0.0	0.0	0.0	0.0
%ile BackOfQ(50%),veh/ln	3.1	2.2	2.2	2.9	2.8	2.8	1.3	4.2	1.6	2.0	3.0	2.3
Unsig. Movement Delay, s/veh												
LnGrp Delay(d),s/veh	34.1	22.9	23.0	33.1	24.9	25.4	35.9	22.1	18.4	37.5	18.5	18.5
LnGrp LOS	C	C	C	C	C	C	D	C	B	D	B	B
Approach Vol, veh/h		551			609			922			888	
Approach Delay, s/veh		26.9			27.6			22.7			21.0	
Approach LOS		C			C			C			C	
Timer - Assigned Phs	1	2	3	4	5	6	7	8				
Phs Duration (G+Y+Rc), s	9.9	20.2	12.6	16.0	8.7	21.5	13.1	15.6				
Change Period (Y+Rc), s	5.0	5.0	5.0	5.0	5.0	5.0	5.0	5.0				
Max Green Setting (Gmax), s	19.0	19.0	11.0	18.0	6.0	20.0	11.0	18.0				
Max Q Clear Time (g_c+1/3), s	12.4	12.4	7.9	7.4	4.6	9.8	8.3	8.9				
Green Ext Time (p_c), s	0.0	2.8	0.1	1.5	0.0	3.3	0.1	1.7				
Intersection Summary												
HCM 6th Ctrl Delay											24.0	
HCM 6th LOS											C	

Heritage at Dalia Ranch
1: SR-86 & Keystone Rd

Opening Year 2023
Timing Plan: AM PEAK

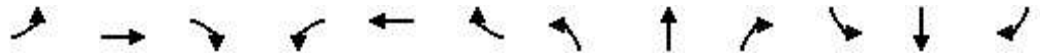

Movement	EBL	EBT	EBR	WBL	WBT	WBR	NBL	NBT	NBR	SBL	SBT	SBR
Lane Configurations		↕			↕		↕	↕↕	↕	↕	↕↕	↕
Traffic Volume (veh/h)	33	33	11	19	24	42	19	439	49	45	512	37
Future Volume (veh/h)	33	33	11	19	24	42	19	439	49	45	512	37
Initial Q (Qb), veh	0	0	0	0	0	0	0	0	0	0	0	0
Ped-Bike Adj(A_pbT)	1.00		1.00	1.00		1.00	1.00		1.00	1.00		1.00
Parking Bus, Adj	1.00	1.00	1.00	1.00	1.00	1.00	1.00	1.00	1.00	1.00	1.00	1.00
Work Zone On Approach		No			No			No			No	
Adj Sat Flow, veh/h/ln	1870	1870	1870	1870	1870	1870	1870	1870	1870	1870	1870	1870
Adj Flow Rate, veh/h	37	37	12	21	27	47	21	488	54	50	569	41
Peak Hour Factor	0.90	0.90	0.90	0.90	0.90	0.90	0.90	0.90	0.90	0.90	0.90	0.90
Percent Heavy Veh, %	2	2	2	2	2	2	2	2	2	2	2	2
Cap, veh/h	261	111	31	191	74	109	48	1003	447	102	1111	496
Arrive On Green	0.13	0.13	0.13	0.13	0.13	0.13	0.03	0.28	0.28	0.06	0.31	0.31
Sat Flow, veh/h	598	829	231	276	556	814	1781	3554	1585	1781	3554	1585
Grp Volume(v), veh/h	86	0	0	95	0	0	21	488	54	50	569	41
Grp Sat Flow(s),veh/h/ln	1659	0	0	1646	0	0	1781	1777	1585	1781	1777	1585
Q Serve(g_s), s	0.0	0.0	0.0	0.2	0.0	0.0	0.3	3.3	0.7	0.8	3.7	0.5
Cycle Q Clear(g_c), s	1.2	0.0	0.0	1.4	0.0	0.0	0.3	3.3	0.7	0.8	3.7	0.5
Prop In Lane	0.43		0.14	0.22		0.49	1.00		1.00	1.00		1.00
Lane Grp Cap(c), veh/h	403	0	0	374	0	0	48	1003	447	102	1111	496
V/C Ratio(X)	0.21	0.00	0.00	0.25	0.00	0.00	0.44	0.49	0.12	0.49	0.51	0.08
Avail Cap(c_a), veh/h	1178	0	0	1169	0	0	313	2247	1002	313	2247	1002
HCM Platoon Ratio	1.00	1.00	1.00	1.00	1.00	1.00	1.00	1.00	1.00	1.00	1.00	1.00
Upstream Filter(l)	1.00	0.00	0.00	1.00	0.00	0.00	1.00	1.00	1.00	1.00	1.00	1.00
Uniform Delay (d), s/veh	11.2	0.0	0.0	11.3	0.0	0.0	13.6	8.5	7.6	13.0	8.0	6.9
Incr Delay (d2), s/veh	0.3	0.0	0.0	0.4	0.0	0.0	6.2	0.4	0.1	3.6	0.4	0.1
Initial Q Delay(d3),s/veh	0.0	0.0	0.0	0.0	0.0	0.0	0.0	0.0	0.0	0.0	0.0	0.0
%ile BackOfQ(50%),veh/ln	0.4	0.0	0.0	0.4	0.0	0.0	0.2	0.8	0.2	0.3	0.9	0.1
Unsig. Movement Delay, s/veh												
LnGrp Delay(d),s/veh	11.5	0.0	0.0	11.7	0.0	0.0	19.8	8.9	7.7	16.6	8.4	7.0
LnGrp LOS	B	A	A	B	A	A	B	A	A	B	A	A
Approach Vol, veh/h		86			95			563			660	
Approach Delay, s/veh		11.5			11.7			9.2			8.9	
Approach LOS		B			B			A			A	
Timer - Assigned Phs	1	2		4	5	6		8				
Phs Duration (G+Y+Rc), s	6.6	13.0		8.8	5.8	13.9		8.8				
Change Period (Y+Rc), s	5.0	5.0		5.0	5.0	5.0		5.0				
Max Green Setting (Gmax), s	5.0	18.0		18.0	5.0	18.0		18.0				
Max Q Clear Time (g_c+I1), s	2.8	5.3		3.2	2.3	5.7		3.4				
Green Ext Time (p_c), s	0.0	2.8		0.3	0.0	3.2		0.4				
Intersection Summary												
HCM 6th Ctrl Delay				9.4								
HCM 6th LOS				A								

Intersection												
Int Delay, s/veh	0.4											
Movement	EBL	EBT	EBR	WBL	WBT	WBR	NBL	NBT	NBR	SBL	SBT	SBR
Lane Configurations		↕			↕		↕	↕		↕	↕	
Traffic Vol, veh/h	20	3	2	1	2	5	0	506	1	1	517	7
Future Vol, veh/h	20	3	2	1	2	5	0	506	1	1	517	7
Conflicting Peds, #/hr	0	0	0	0	0	0	0	0	0	0	0	0
Sign Control	Stop	Stop	Stop	Stop	Stop	Stop	Free	Free	Free	Free	Free	Free
RT Channelized	-	-	None	-	-	None	-	-	None	-	-	None
Storage Length	-	-	-	-	-	-	50	-	-	50	-	-
Veh in Median Storage, #	-	1	-	-	1	-	-	0	-	-	0	-
Grade, %	-	0	-	-	0	-	-	0	-	-	0	-
Peak Hour Factor	94	94	94	94	94	94	94	94	94	94	94	94
Heavy Vehicles, %	2	2	2	2	2	2	2	2	2	2	2	2
Mvmt Flow	21	3	2	1	2	5	0	538	1	1	550	7

Major/Minor	Minor2		Minor1		Major1			Major2				
Conflicting Flow All	826	1095	279	818	1098	270	557	0	0	539	0	0
Stage 1	556	556	-	539	539	-	-	-	-	-	-	-
Stage 2	270	539	-	279	559	-	-	-	-	-	-	-
Critical Hdwy	7.54	6.54	6.94	7.54	6.54	6.94	4.14	-	-	4.14	-	-
Critical Hdwy Stg 1	6.54	5.54	-	6.54	5.54	-	-	-	-	-	-	-
Critical Hdwy Stg 2	6.54	5.54	-	6.54	5.54	-	-	-	-	-	-	-
Follow-up Hdwy	3.52	4.02	3.32	3.52	4.02	3.32	2.22	-	-	2.22	-	-
Pot Cap-1 Maneuver	264	212	718	268	211	728	1010	-	-	1025	-	-
Stage 1	483	511	-	494	520	-	-	-	-	-	-	-
Stage 2	713	520	-	704	509	-	-	-	-	-	-	-
Platoon blocked, %								-	-	-	-	-
Mov Cap-1 Maneuver	261	212	718	265	211	728	1010	-	-	1025	-	-
Mov Cap-2 Maneuver	373	332	-	379	331	-	-	-	-	-	-	-
Stage 1	483	510	-	494	520	-	-	-	-	-	-	-
Stage 2	705	520	-	697	508	-	-	-	-	-	-	-

Approach	EB		WB		NB		SB	
HCM Control Delay, s	15.1		12.1		0		0	
HCM LOS	C		B					

Minor Lane/Major Mvmt	NBL	NBT	NBR	EBLn1	WBLn1	SBL	SBT	SBR
Capacity (veh/h)	1010	-	-	382	515	1025	-	-
HCM Lane V/C Ratio	-	-	-	0.07	0.017	0.001	-	-
HCM Control Delay (s)	0	-	-	15.1	12.1	8.5	-	-
HCM Lane LOS	A	-	-	C	B	A	-	-
HCM 95th %tile Q(veh)	0	-	-	0.2	0.1	0	-	-

Intersection						
Int Delay, s/veh	1.5					
Movement	WBL	WBR	NBT	NBR	SBL	SBT
Lane Configurations	↔		↑↑		↔	↑↑
Traffic Vol, veh/h	59	23	484	41	20	500
Future Vol, veh/h	59	23	484	41	20	500
Conflicting Peds, #/hr	0	0	0	0	0	0
Sign Control	Stop	Stop	Free	Free	Free	Free
RT Channelized	-	None	-	None	-	None
Storage Length	0	-	-	-	140	-
Veh in Median Storage, #	0	-	0	-	-	0
Grade, %	0	-	0	-	-	0
Peak Hour Factor	91	91	91	91	91	91
Heavy Vehicles, %	2	2	2	2	2	2
Mvmt Flow	65	25	532	45	22	549

Major/Minor	Minor1	Major1	Major2		
Conflicting Flow All	874	289	0	0	577
Stage 1	555	-	-	-	-
Stage 2	319	-	-	-	-
Critical Hdwy	6.84	6.94	-	-	4.14
Critical Hdwy Stg 1	5.84	-	-	-	-
Critical Hdwy Stg 2	5.84	-	-	-	-
Follow-up Hdwy	3.52	3.32	-	-	2.22
Pot Cap-1 Maneuver	289	708	-	-	993
Stage 1	539	-	-	-	-
Stage 2	710	-	-	-	-
Platoon blocked, %			-	-	-
Mov Cap-1 Maneuver	283	708	-	-	993
Mov Cap-2 Maneuver	283	-	-	-	-
Stage 1	539	-	-	-	-
Stage 2	694	-	-	-	-

Approach	WB	NB	SB
HCM Control Delay, s	19.4	0	0.3
HCM LOS	C		

Minor Lane/Major Mvmt	NBT	NBRWBLn1	SBL	SBT
Capacity (veh/h)	-	-	340	993
HCM Lane V/C Ratio	-	-	0.265	0.022
HCM Control Delay (s)	-	-	19.4	8.7
HCM Lane LOS	-	-	C	A
HCM 95th %tile Q(veh)	-	-	1	0.1

Heritage at Dalia Ranch
4: Imperial Ave & Neckel Rd

Opening Year 2023
Timing Plan: AM PEAK

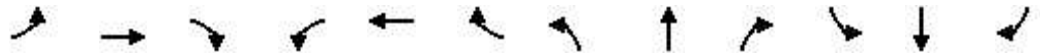

Movement	EBL	EBT	EBR	WBL	WBT	WBR	NBL	NBT	NBR	SBL	SBT	SBR
Lane Configurations		↕			↕		↕	↕		↕	↕	
Traffic Volume (veh/h)	34	43	12	142	64	56	8	442	65	14	511	31
Future Volume (veh/h)	34	43	12	142	64	56	8	442	65	14	511	31
Initial Q (Qb), veh	0	0	0	0	0	0	0	0	0	0	0	0
Ped-Bike Adj(A_pbT)	1.00		1.00	1.00		1.00	1.00		1.00	1.00		1.00
Parking Bus, Adj	1.00	1.00	1.00	1.00	1.00	1.00	1.00	1.00	1.00	1.00	1.00	1.00
Work Zone On Approach		No			No			No			No	
Adj Sat Flow, veh/h/ln	1870	1870	1870	1870	1870	1870	1870	1870	1870	1870	1870	1870
Adj Flow Rate, veh/h	37	47	13	156	70	62	9	486	71	15	562	34
Peak Hour Factor	0.91	0.91	0.91	0.91	0.91	0.91	0.91	0.91	0.91	0.91	0.91	0.91
Percent Heavy Veh, %	2	2	2	2	2	2	2	2	2	2	2	2
Cap, veh/h	53	68	19	206	92	82	21	759	110	34	855	52
Arrive On Green	0.08	0.08	0.08	0.22	0.22	0.22	0.01	0.24	0.24	0.02	0.25	0.25
Sat Flow, veh/h	684	869	240	951	427	378	1781	3113	453	1781	3405	206
Grp Volume(v), veh/h	97	0	0	288	0	0	9	276	281	15	293	303
Grp Sat Flow(s),veh/h/ln	1793	0	0	1755	0	0	1781	1777	1789	1781	1777	1833
Q Serve(g_s), s	2.4	0.0	0.0	7.0	0.0	0.0	0.2	6.3	6.4	0.4	6.7	6.7
Cycle Q Clear(g_c), s	2.4	0.0	0.0	7.0	0.0	0.0	0.2	6.3	6.4	0.4	6.7	6.7
Prop In Lane	0.38		0.13	0.54		0.22	1.00		0.25	1.00		0.11
Lane Grp Cap(c), veh/h	140	0	0	380	0	0	21	433	436	34	446	460
V/C Ratio(X)	0.69	0.00	0.00	0.76	0.00	0.00	0.43	0.64	0.64	0.44	0.66	0.66
Avail Cap(c_a), veh/h	714	0	0	699	0	0	197	747	752	197	747	771
HCM Platoon Ratio	1.00	1.00	1.00	1.00	1.00	1.00	1.00	1.00	1.00	1.00	1.00	1.00
Upstream Filter(l)	1.00	0.00	0.00	1.00	0.00	0.00	1.00	1.00	1.00	1.00	1.00	1.00
Uniform Delay (d), s/veh	20.3	0.0	0.0	16.6	0.0	0.0	22.2	15.3	15.3	21.9	15.2	15.2
Incr Delay (d2), s/veh	6.1	0.0	0.0	3.1	0.0	0.0	13.1	1.6	1.6	8.8	1.6	1.6
Initial Q Delay(d3),s/veh	0.0	0.0	0.0	0.0	0.0	0.0	0.0	0.0	0.0	0.0	0.0	0.0
%ile BackOfQ(50%),veh/ln	1.1	0.0	0.0	2.7	0.0	0.0	0.2	2.3	2.4	0.2	2.5	2.6
Unsig. Movement Delay, s/veh												
LnGrp Delay(d),s/veh	26.4	0.0	0.0	19.7	0.0	0.0	35.3	16.9	16.9	30.8	16.8	16.8
LnGrp LOS	C	A	A	B	A	A	D	B	B	C	B	B
Approach Vol, veh/h		97			288			566				611
Approach Delay, s/veh		26.4			19.7			17.2				17.2
Approach LOS		C			B			B				B
Timer - Assigned Phs	1	2		4	5	6		8				
Phs Duration (G+Y+Rc), s	5.9	16.0		8.5	5.5	16.3		14.8				
Change Period (Y+Rc), s	5.0	5.0		5.0	5.0	5.0		5.0				
Max Green Setting (Gmax), s	5.0	19.0		18.0	5.0	19.0		18.0				
Max Q Clear Time (g_c+I1), s	2.4	8.4		4.4	2.2	8.7		9.0				
Green Ext Time (p_c), s	0.0	2.5		0.3	0.0	2.6		1.1				
Intersection Summary												
HCM 6th Ctrl Delay				18.2								
HCM 6th LOS				B								

Intersection												
Int Delay, s/veh	7.6											
Movement	EBL	EBT	EBR	WBL	WBT	WBR	NBL	NBT	NBR	SBL	SBT	SBR
Lane Configurations		↕			↕			↕			↕	
Traffic Vol, veh/h	4	41	23	60	44	0	7	6	42	1	2	1
Future Vol, veh/h	4	41	23	60	44	0	7	6	42	1	2	1
Conflicting Peds, #/hr	0	0	0	0	0	0	0	0	0	0	0	0
Sign Control	Stop	Stop	Stop	Stop	Stop	Stop	Free	Free	Free	Free	Free	Free
RT Channelized	-	-	None	-	-	None	-	-	None	-	-	None
Storage Length	-	-	-	-	-	-	-	-	-	-	-	-
Veh in Median Storage, #	-	0	-	-	0	-	-	0	-	-	0	-
Grade, %	-	0	-	-	0	-	-	0	-	-	0	-
Peak Hour Factor	79	79	79	79	79	79	79	79	79	79	79	79
Heavy Vehicles, %	2	2	2	2	2	2	2	2	2	2	2	2
Mvmt Flow	5	52	29	76	56	0	9	8	53	1	3	1

Major/Minor	Minor2		Minor1		Major1			Major2				
Conflicting Flow All	87	85	4	99	59	35	4	0	0	61	0	0
Stage 1	6	6	-	53	53	-	-	-	-	-	-	-
Stage 2	81	79	-	46	6	-	-	-	-	-	-	-
Critical Hdwy	7.12	6.52	6.22	7.12	6.52	6.22	4.12	-	-	4.12	-	-
Critical Hdwy Stg 1	6.12	5.52	-	6.12	5.52	-	-	-	-	-	-	-
Critical Hdwy Stg 2	6.12	5.52	-	6.12	5.52	-	-	-	-	-	-	-
Follow-up Hdwy	3.518	4.018	3.318	3.518	4.018	3.318	2.218	-	-	2.218	-	-
Pot Cap-1 Maneuver	899	805	1080	883	832	1038	1618	-	-	1542	-	-
Stage 1	1016	891	-	960	851	-	-	-	-	-	-	-
Stage 2	927	829	-	968	891	-	-	-	-	-	-	-
Platoon blocked, %								-	-	-	-	-
Mov Cap-1 Maneuver	848	799	1080	812	826	1038	1618	-	-	1542	-	-
Mov Cap-2 Maneuver	848	799	-	812	826	-	-	-	-	-	-	-
Stage 1	1010	890	-	954	846	-	-	-	-	-	-	-
Stage 2	861	824	-	886	890	-	-	-	-	-	-	-

Approach	EB		WB		NB		SB	
HCM Control Delay, s	9.5		10.2		0.9		1.8	
HCM LOS	A		B					

Minor Lane/Major Mvmt	NBL	NBT	NBR	EBLn1	WBLn1	SBL	SBT	SBR
Capacity (veh/h)	1618	-	-	879	818	1542	-	-
HCM Lane V/C Ratio	0.005	-	-	0.098	0.161	0.001	-	-
HCM Control Delay (s)	7.2	0	-	9.5	10.2	7.3	0	-
HCM Lane LOS	A	A	-	A	B	A	A	-
HCM 95th %tile Q(veh)	0	-	-	0.3	0.6	0	-	-

Heritage at Dalia Ranch
6: Imperial Ave & Worthington Rd/Barioni Blvd

Opening Year 2023
Timing Plan: AM PEAK

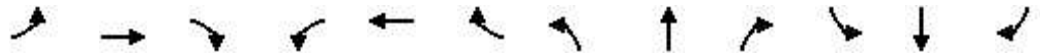

Movement	EBL	EBT	EBR	WBL	WBT	WBR	NBL	NBT	NBR	SBL	SBT	SBR
Lane Configurations		↕	↗		↕	↗	↗	↕↗		↗	↕↗	
Traffic Volume (veh/h)	70	136	212	54	132	77	93	465	50	39	630	56
Future Volume (veh/h)	70	136	212	54	132	77	93	465	50	39	630	56
Initial Q (Qb), veh	0	0	0	0	0	0	0	0	0	0	0	0
Ped-Bike Adj(A_pbT)	1.00		1.00	1.00		1.00	1.00		1.00	1.00		1.00
Parking Bus, Adj	1.00	1.00	1.00	1.00	1.00	1.00	1.00	1.00	1.00	1.00	1.00	1.00
Work Zone On Approach		No			No			No			No	
Adj Sat Flow, veh/h/ln	1870	1870	1870	1870	1870	1870	1870	1870	1870	1870	1870	1870
Adj Flow Rate, veh/h	79	153	238	61	148	87	104	522	56	44	708	63
Peak Hour Factor	0.89	0.89	0.89	0.89	0.89	0.89	0.89	0.89	0.89	0.89	0.89	0.89
Percent Heavy Veh, %	2	2	2	2	2	2	2	2	2	2	2	2
Cap, veh/h	122	235	308	83	201	244	133	953	102	76	865	77
Arrive On Green	0.19	0.19	0.19	0.15	0.15	0.15	0.07	0.29	0.29	0.04	0.26	0.26
Sat Flow, veh/h	626	1213	1585	538	1305	1585	1781	3238	346	1781	3301	294
Grp Volume(v), veh/h	232	0	238	209	0	87	104	286	292	44	381	390
Grp Sat Flow(s),veh/h/ln	1839	0	1585	1843	0	1585	1781	1777	1808	1781	1777	1818
Q Serve(g_s), s	7.4	0.0	9.0	6.9	0.0	3.1	3.6	8.6	8.6	1.5	12.8	12.8
Cycle Q Clear(g_c), s	7.4	0.0	9.0	6.9	0.0	3.1	3.6	8.6	8.6	1.5	12.8	12.8
Prop In Lane	0.34		1.00	0.29		1.00	1.00		0.19	1.00		0.16
Lane Grp Cap(c), veh/h	357	0	308	284	0	244	133	523	532	76	466	476
V/C Ratio(X)	0.65	0.00	0.77	0.74	0.00	0.36	0.78	0.55	0.55	0.58	0.82	0.82
Avail Cap(c_a), veh/h	522	0	449	523	0	449	140	532	541	140	532	544
HCM Platoon Ratio	1.00	1.00	1.00	1.00	1.00	1.00	1.00	1.00	1.00	1.00	1.00	1.00
Upstream Filter(l)	1.00	0.00	1.00	1.00	0.00	1.00	1.00	1.00	1.00	1.00	1.00	1.00
Uniform Delay (d), s/veh	23.6	0.0	24.3	25.6	0.0	24.0	28.9	18.8	18.9	29.8	22.0	22.0
Incr Delay (d2), s/veh	2.0	0.0	5.0	3.7	0.0	0.9	23.3	1.1	1.1	6.9	8.7	8.6
Initial Q Delay(d3),s/veh	0.0	0.0	0.0	0.0	0.0	0.0	0.0	0.0	0.0	0.0	0.0	0.0
%ile BackOfQ(50%),veh/ln	3.2	0.0	3.6	3.1	0.0	1.2	2.3	3.4	3.5	0.8	6.0	6.2
Unsig. Movement Delay, s/veh												
LnGrp Delay(d),s/veh	25.6	0.0	29.3	29.3	0.0	24.9	52.1	20.0	20.0	36.7	30.7	30.6
LnGrp LOS	C	A	C	C	A	C	D	B	B	D	C	C
Approach Vol, veh/h		470			296			682			815	
Approach Delay, s/veh		27.4			28.0			24.9			31.0	
Approach LOS		C			C			C			C	
Timer - Assigned Phs	1	2		4	5	6		8				
Phs Duration (G+Y+Rc), s	7.7	23.7		17.3	9.7	21.6		14.8				
Change Period (Y+Rc), s	5.0	5.0		5.0	5.0	5.0		5.0				
Max Green Setting (Gmax), s	5.0	19.0		18.0	5.0	19.0		18.0				
Max Q Clear Time (g_c+I1), s	3.5	10.6		11.0	5.6	14.8		8.9				
Green Ext Time (p_c), s	0.0	2.3		1.3	0.0	1.8		1.0				
Intersection Summary												
HCM 6th Ctrl Delay				28.0								
HCM 6th LOS				C								

Intersection												
Intersection Delay, s/veh	19.3											
Intersection LOS	C											

Movement	EBL	EBT	EBR	WBL	WBT	WBR	NBL	NBT	NBR	SBL	SBT	SBR
Lane Configurations		↔	↔		↔	↔		↔			↔	
Traffic Vol, veh/h	61	390	119	11	301	77	0	0	1	106	31	64
Future Vol, veh/h	61	390	119	11	301	77	0	0	1	106	31	64
Peak Hour Factor	0.92	0.92	0.92	0.92	0.92	0.92	0.92	0.92	0.92	0.92	0.92	0.92
Heavy Vehicles, %	2	2	2	2	2	2	2	2	2	2	2	2
Mvmt Flow	66	424	129	12	327	84	0	0	1	115	34	70
Number of Lanes	0	1	1	0	1	1	0	1	0	0	1	0

Approach	EB	WB	NB	SB
Opposing Approach	WB	EB	SB	NB
Opposing Lanes	2	2	1	1
Conflicting Approach Left	SB	NB	EB	WB
Conflicting Lanes Left	1	1	2	2
Conflicting Approach Right	NB	SB	WB	EB
Conflicting Lanes Right	1	1	2	2
HCM Control Delay	24.3	15.1	9.6	13.2
HCM LOS	C	C	A	B

Lane	NBLn1	EBLn1	EBLn2	WBLn1	WBLn2	SBLn1
Vol Left, %	0%	14%	0%	4%	0%	53%
Vol Thru, %	0%	86%	0%	96%	0%	15%
Vol Right, %	100%	0%	100%	0%	100%	32%
Sign Control	Stop	Stop	Stop	Stop	Stop	Stop
Traffic Vol by Lane	1	451	119	312	77	201
LT Vol	0	61	0	11	0	106
Through Vol	0	390	0	301	0	31
RT Vol	1	0	119	0	77	64
Lane Flow Rate	1	490	129	339	84	218
Geometry Grp	2	7	7	7	7	2
Degree of Util (X)	0.002	0.802	0.184	0.572	0.124	0.381
Departure Headway (Hd)	6.471	5.889	5.111	6.068	5.339	6.275
Convergence, Y/N	Yes	Yes	Yes	Yes	Yes	Yes
Cap	549	613	701	593	670	572
Service Time	4.559	3.629	2.851	3.815	3.086	4.328
HCM Lane V/C Ratio	0.002	0.799	0.184	0.572	0.125	0.381
HCM Control Delay	9.6	28.3	9	16.7	8.8	13.2
HCM Lane LOS	A	D	A	C	A	B
HCM 95th-tile Q	0	7.9	0.7	3.6	0.4	1.8

Heritage at Dalia Ranch
8: Imperial Ave & Aten Rd

Opening Year 2023
Timing Plan: AM PEAK



Movement	EBL	EBT	EBR	WBL	WBT	WBR	NBL	NBT	NBR	SBL	SBT	SBR
Lane Configurations												
Traffic Volume (veh/h)	186	337	63	131	299	141	61	343	67	142	670	375
Future Volume (veh/h)	186	337	63	131	299	141	61	343	67	142	670	375
Initial Q (Qb), veh	0	0	0	0	0	0	0	0	0	0	0	0
Ped-Bike Adj(A_pbT)	1.00		1.00	1.00		1.00	1.00		1.00	1.00		1.00
Parking Bus, Adj	1.00	1.00	1.00	1.00	1.00	1.00	1.00	1.00	1.00	1.00	1.00	1.00
Work Zone On Approach		No			No			No			No	
Adj Sat Flow, veh/h/ln	1870	1870	1870	1870	1870	1870	1870	1870	1870	1870	1870	1870
Adj Flow Rate, veh/h	216	392	73	152	348	164	71	399	78	165	779	436
Peak Hour Factor	0.86	0.86	0.86	0.86	0.86	0.86	0.86	0.86	0.86	0.86	0.86	0.86
Percent Heavy Veh, %	2	2	2	2	2	2	2	2	2	2	2	2
Cap, veh/h	258	700	129	191	462	214	97	893	398	204	1107	494
Arrive On Green	0.14	0.23	0.23	0.11	0.20	0.20	0.05	0.25	0.25	0.11	0.31	0.31
Sat Flow, veh/h	1781	2995	553	1781	2359	1092	1781	3554	1585	1781	3554	1585
Grp Volume(v), veh/h	216	231	234	152	261	251	71	399	78	165	779	436
Grp Sat Flow(s),veh/h/ln	1781	1777	1771	1781	1777	1674	1781	1777	1585	1781	1777	1585
Q Serve(g_s), s	8.0	7.8	7.9	5.7	9.4	9.7	2.7	6.5	2.6	6.2	13.2	17.8
Cycle Q Clear(g_c), s	8.0	7.8	7.9	5.7	9.4	9.7	2.7	6.5	2.6	6.2	13.2	17.8
Prop In Lane	1.00		0.31	1.00		0.65	1.00		1.00	1.00		1.00
Lane Grp Cap(c), veh/h	258	415	414	191	348	328	97	893	398	204	1107	494
V/C Ratio(X)	0.84	0.56	0.56	0.80	0.75	0.77	0.73	0.45	0.20	0.81	0.70	0.88
Avail Cap(c_a), veh/h	261	495	494	235	469	442	131	991	442	209	1147	512
HCM Platoon Ratio	1.00	1.00	1.00	1.00	1.00	1.00	1.00	1.00	1.00	1.00	1.00	1.00
Upstream Filter(I)	1.00	1.00	1.00	1.00	1.00	1.00	1.00	1.00	1.00	1.00	1.00	1.00
Uniform Delay (d), s/veh	28.4	23.0	23.1	29.7	25.8	25.9	31.7	21.5	20.1	29.4	20.7	22.3
Incr Delay (d2), s/veh	20.4	1.2	1.2	14.3	4.5	5.6	13.2	0.4	0.2	20.3	1.9	16.1
Initial Q Delay(d3),s/veh	0.0	0.0	0.0	0.0	0.0	0.0	0.0	0.0	0.0	0.0	0.0	0.0
%ile BackOfQ(50%),veh/ln	4.7	3.2	3.3	3.1	4.2	4.2	1.5	2.6	1.0	3.7	5.4	8.3
Unsig. Movement Delay, s/veh												
LnGrp Delay(d),s/veh	48.8	24.2	24.3	44.0	30.3	31.5	45.0	21.9	20.3	49.7	22.6	38.4
LnGrp LOS	D	C	C	D	C	C	D	C	C	D	C	D
Approach Vol, veh/h		681			664			548			1380	
Approach Delay, s/veh		32.0			33.9			24.6			30.8	
Approach LOS		C			C			C			C	
Timer - Assigned Phs	1	2	3	4	5	6	7	8				
Phs Duration (G+Y+Rc), s	22.8	22.1	12.3	20.9	8.7	26.2	14.9	18.3				
Change Period (Y+Rc), s	5.0	5.0	5.0	5.0	5.0	5.0	5.0	5.0				
Max Green Setting (Gmax), s	19.0	19.0	9.0	19.0	5.0	22.0	10.0	18.0				
Max Q Clear Time (g_c+1/2), s	8.5	8.5	7.7	9.9	4.7	19.8	10.0	11.7				
Green Ext Time (p_c), s	0.0	2.1	0.0	1.9	0.0	1.4	0.0	1.7				
Intersection Summary												
HCM 6th Ctrl Delay											30.7	
HCM 6th LOS											C	

Heritage at Dalia Ranch
1: SR-86 & Keystone Rd

Opening Year 2023
Timing Plan: PM PEAK

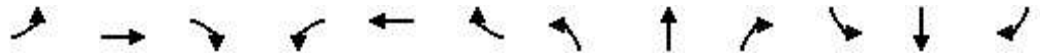

Movement	EBL	EBT	EBR	WBL	WBT	WBR	NBL	NBT	NBR	SBL	SBT	SBR
Lane Configurations		↕			↕		↕	↕↕	↕	↕	↕↕	↕
Traffic Volume (veh/h)	41	12	20	33	27	37	10	523	26	52	542	34
Future Volume (veh/h)	41	12	20	33	27	37	10	523	26	52	542	34
Initial Q (Qb), veh	0	0	0	0	0	0	0	0	0	0	0	0
Ped-Bike Adj(A_pbT)	1.00		1.00	1.00		1.00	1.00		1.00	1.00		1.00
Parking Bus, Adj	1.00	1.00	1.00	1.00	1.00	1.00	1.00	1.00	1.00	1.00	1.00	1.00
Work Zone On Approach		No			No			No			No	
Adj Sat Flow, veh/h/ln	1870	1870	1870	1870	1870	1870	1870	1870	1870	1870	1870	1870
Adj Flow Rate, veh/h	46	13	22	37	30	42	11	588	29	58	609	38
Peak Hour Factor	0.89	0.89	0.89	0.89	0.89	0.89	0.89	0.89	0.89	0.89	0.89	0.89
Percent Heavy Veh, %	2	2	2	2	2	2	2	2	2	2	2	2
Cap, veh/h	288	50	57	217	71	83	26	1127	502	113	1301	580
Arrive On Green	0.13	0.13	0.13	0.13	0.13	0.13	0.01	0.32	0.32	0.06	0.37	0.37
Sat Flow, veh/h	795	383	439	461	547	631	1781	3554	1585	1781	3554	1585
Grp Volume(v), veh/h	81	0	0	109	0	0	11	588	29	58	609	38
Grp Sat Flow(s),veh/h/ln	1617	0	0	1639	0	0	1781	1777	1585	1781	1777	1585
Q Serve(g_s), s	0.0	0.0	0.0	0.5	0.0	0.0	0.2	4.2	0.4	1.0	4.0	0.5
Cycle Q Clear(g_c), s	1.3	0.0	0.0	1.8	0.0	0.0	0.2	4.2	0.4	1.0	4.0	0.5
Prop In Lane	0.57		0.27	0.34		0.39	1.00		1.00	1.00		1.00
Lane Grp Cap(c), veh/h	395	0	0	371	0	0	26	1127	502	113	1301	580
V/C Ratio(X)	0.20	0.00	0.00	0.29	0.00	0.00	0.42	0.52	0.06	0.51	0.47	0.07
Avail Cap(c_a), veh/h	1061	0	0	1086	0	0	290	2432	1085	348	2547	1136
HCM Platoon Ratio	1.00	1.00	1.00	1.00	1.00	1.00	1.00	1.00	1.00	1.00	1.00	1.00
Upstream Filter(l)	1.00	0.00	0.00	1.00	0.00	0.00	1.00	1.00	1.00	1.00	1.00	1.00
Uniform Delay (d), s/veh	12.1	0.0	0.0	12.4	0.0	0.0	15.0	8.6	7.3	13.9	7.4	6.3
Incr Delay (d2), s/veh	0.3	0.0	0.0	0.4	0.0	0.0	10.6	0.4	0.0	3.6	0.3	0.0
Initial Q Delay(d3),s/veh	0.0	0.0	0.0	0.0	0.0	0.0	0.0	0.0	0.0	0.0	0.0	0.0
%ile BackOfQ(50%),veh/ln	0.4	0.0	0.0	0.6	0.0	0.0	0.1	1.1	0.1	0.4	1.0	0.1
Unsig. Movement Delay, s/veh												
LnGrp Delay(d),s/veh	12.4	0.0	0.0	12.8	0.0	0.0	25.6	9.0	7.3	17.5	7.7	6.4
LnGrp LOS	B	A	A	B	A	A	C	A	A	B	A	A
Approach Vol, veh/h		81			109			628			705	
Approach Delay, s/veh		12.4			12.8			9.2			8.4	
Approach LOS		B			B			A			A	
Timer - Assigned Phs	1	2		4	5	6		8				
Phs Duration (G+Y+Rc), s	7.0	14.7		9.0	5.4	16.2		9.0				
Change Period (Y+Rc), s	5.0	5.0		5.0	5.0	5.0		5.0				
Max Green Setting (Gmax), s	6.0	21.0		18.0	5.0	22.0		18.0				
Max Q Clear Time (g_c+I1), s	3.0	6.2		3.3	2.2	6.0		3.8				
Green Ext Time (p_c), s	0.0	3.6		0.3	0.0	3.9		0.4				
Intersection Summary												
HCM 6th Ctrl Delay				9.3								
HCM 6th LOS				A								

Intersection												
Int Delay, s/veh	0.3											
Movement	EBL	EBT	EBR	WBL	WBT	WBR	NBL	NBT	NBR	SBL	SBT	SBR
Lane Configurations		↕			↕		↕	↕		↕	↕	
Traffic Vol, veh/h	6	4	0	7	0	5	1	561	7	6	578	17
Future Vol, veh/h	6	4	0	7	0	5	1	561	7	6	578	17
Conflicting Peds, #/hr	0	0	0	0	0	0	0	0	0	0	0	0
Sign Control	Stop	Stop	Stop	Stop	Stop	Stop	Free	Free	Free	Free	Free	Free
RT Channelized	-	-	None	-	-	None	-	-	None	-	-	None
Storage Length	-	-	-	-	-	-	50	-	-	50	-	-
Veh in Median Storage, #	-	1	-	-	1	-	-	0	-	-	0	-
Grade, %	-	0	-	-	0	-	-	0	-	-	0	-
Peak Hour Factor	92	92	92	92	92	92	92	92	92	92	92	92
Heavy Vehicles, %	2	2	2	2	2	2	2	2	2	2	2	2
Mvmt Flow	7	4	0	8	0	5	1	610	8	7	628	18

Major/Minor	Minor2		Minor1		Major1			Major2				
Conflicting Flow All	958	1271	323	946	1276	309	646	0	0	618	0	0
Stage 1	651	651	-	616	616	-	-	-	-	-	-	-
Stage 2	307	620	-	330	660	-	-	-	-	-	-	-
Critical Hdwy	7.54	6.54	6.94	7.54	6.54	6.94	4.14	-	-	4.14	-	-
Critical Hdwy Stg 1	6.54	5.54	-	6.54	5.54	-	-	-	-	-	-	-
Critical Hdwy Stg 2	6.54	5.54	-	6.54	5.54	-	-	-	-	-	-	-
Follow-up Hdwy	3.52	4.02	3.32	3.52	4.02	3.32	2.22	-	-	2.22	-	-
Pot Cap-1 Maneuver	212	167	673	216	165	687	935	-	-	958	-	-
Stage 1	424	463	-	445	480	-	-	-	-	-	-	-
Stage 2	678	478	-	657	458	-	-	-	-	-	-	-
Platoon blocked, %								-	-	-	-	-
Mov Cap-1 Maneuver	209	166	673	212	164	687	935	-	-	958	-	-
Mov Cap-2 Maneuver	324	288	-	332	288	-	-	-	-	-	-	-
Stage 1	424	460	-	445	480	-	-	-	-	-	-	-
Stage 2	672	478	-	646	455	-	-	-	-	-	-	-

Approach	EB		WB		NB		SB	
HCM Control Delay, s	17.1		13.8		0		0.1	
HCM LOS	C		B					

Minor Lane/Major Mvmt	NBL	NBT	NBR	EBLn1	WBLn1	SBL	SBT	SBR
Capacity (veh/h)	935	-	-	309	423	958	-	-
HCM Lane V/C Ratio	0.001	-	-	0.035	0.031	0.007	-	-
HCM Control Delay (s)	8.9	-	-	17.1	13.8	8.8	-	-
HCM Lane LOS	A	-	-	C	B	A	-	-
HCM 95th %tile Q(veh)	0	-	-	0.1	0.1	0	-	-

Intersection						
Int Delay, s/veh	0.7					
Movement	WBL	WBR	NBT	NBR	SBL	SBT
Lane Configurations	↔		↑↓		↔	↑↑
Traffic Vol, veh/h	20	10	562	30	30	542
Future Vol, veh/h	20	10	562	30	30	542
Conflicting Peds, #/hr	0	0	0	0	0	0
Sign Control	Stop	Stop	Free	Free	Free	Free
RT Channelized	-	None	-	None	-	None
Storage Length	0	-	-	-	140	-
Veh in Median Storage, #	0	-	0	-	-	0
Grade, %	0	-	0	-	-	0
Peak Hour Factor	91	91	91	91	91	91
Heavy Vehicles, %	2	2	2	2	2	2
Mvmt Flow	22	11	618	33	33	596

Major/Minor	Minor1	Major1	Major2			
Conflicting Flow All	999	326	0	0	651	0
Stage 1	635	-	-	-	-	-
Stage 2	364	-	-	-	-	-
Critical Hdwy	6.84	6.94	-	-	4.14	-
Critical Hdwy Stg 1	5.84	-	-	-	-	-
Critical Hdwy Stg 2	5.84	-	-	-	-	-
Follow-up Hdwy	3.52	3.32	-	-	2.22	-
Pot Cap-1 Maneuver	240	670	-	-	931	-
Stage 1	490	-	-	-	-	-
Stage 2	673	-	-	-	-	-
Platoon blocked, %			-	-		
Mov Cap-1 Maneuver	232	670	-	-	931	-
Mov Cap-2 Maneuver	232	-	-	-	-	-
Stage 1	490	-	-	-	-	-
Stage 2	649	-	-	-	-	-

Approach	WB	NB	SB
HCM Control Delay, s	18.6	0	0.5
HCM LOS	C		

Minor Lane/Major Mvmt	NBT	NBRWBLn1	SBL	SBT
Capacity (veh/h)	-	-	297	931
HCM Lane V/C Ratio	-	-	0.111	0.035
HCM Control Delay (s)	-	-	18.6	9
HCM Lane LOS	-	-	C	A
HCM 95th %tile Q(veh)	-	-	0.4	0.1

Heritage at Dalia Ranch
4: Imperial Ave & Neckel Rd

Opening Year 2023
Timing Plan: PM PEAK

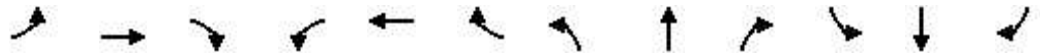

Movement	EBL	EBT	EBR	WBL	WBT	WBR	NBL	NBT	NBR	SBL	SBT	SBR
Lane Configurations		↕			↕		↕	↕		↕	↕	
Traffic Volume (veh/h)	12	26	4	82	20	46	11	555	83	29	496	28
Future Volume (veh/h)	12	26	4	82	20	46	11	555	83	29	496	28
Initial Q (Qb), veh	0	0	0	0	0	0	0	0	0	0	0	0
Ped-Bike Adj(A_pbT)	1.00		1.00	1.00		1.00	1.00		1.00	1.00		1.00
Parking Bus, Adj	1.00	1.00	1.00	1.00	1.00	1.00	1.00	1.00	1.00	1.00	1.00	1.00
Work Zone On Approach		No			No			No			No	
Adj Sat Flow, veh/h/ln	1870	1870	1870	1870	1870	1870	1870	1870	1870	1870	1870	1870
Adj Flow Rate, veh/h	13	28	4	89	22	50	12	603	90	32	539	30
Peak Hour Factor	0.92	0.92	0.92	0.92	0.92	0.92	0.92	0.92	0.92	0.92	0.92	0.92
Percent Heavy Veh, %	2	2	2	2	2	2	2	2	2	2	2	2
Cap, veh/h	26	55	8	123	31	69	28	916	136	66	1085	60
Arrive On Green	0.05	0.05	0.05	0.13	0.13	0.13	0.02	0.30	0.30	0.04	0.32	0.32
Sat Flow, veh/h	524	1129	161	954	236	536	1781	3102	462	1781	3423	190
Grp Volume(v), veh/h	45	0	0	161	0	0	12	345	348	32	279	290
Grp Sat Flow(s),veh/h/ln	1815	0	0	1726	0	0	1781	1777	1787	1781	1777	1836
Q Serve(g_s), s	1.0	0.0	0.0	3.7	0.0	0.0	0.3	6.9	7.0	0.7	5.2	5.2
Cycle Q Clear(g_c), s	1.0	0.0	0.0	3.7	0.0	0.0	0.3	6.9	7.0	0.7	5.2	5.2
Prop In Lane	0.29		0.09	0.55		0.31	1.00		0.26	1.00		0.10
Lane Grp Cap(c), veh/h	89	0	0	223	0	0	28	525	528	66	563	582
V/C Ratio(X)	0.51	0.00	0.00	0.72	0.00	0.00	0.43	0.66	0.66	0.48	0.50	0.50
Avail Cap(c_a), veh/h	799	0	0	760	0	0	218	826	830	218	826	853
HCM Platoon Ratio	1.00	1.00	1.00	1.00	1.00	1.00	1.00	1.00	1.00	1.00	1.00	1.00
Upstream Filter(I)	1.00	0.00	0.00	1.00	0.00	0.00	1.00	1.00	1.00	1.00	1.00	1.00
Uniform Delay (d), s/veh	19.0	0.0	0.0	17.1	0.0	0.0	19.9	12.6	12.6	19.3	11.3	11.3
Incr Delay (d2), s/veh	4.4	0.0	0.0	4.3	0.0	0.0	10.3	1.4	1.4	5.3	0.7	0.7
Initial Q Delay(d3),s/veh	0.0	0.0	0.0	0.0	0.0	0.0	0.0	0.0	0.0	0.0	0.0	0.0
%ile BackOfQ(50%),veh/ln	0.5	0.0	0.0	1.5	0.0	0.0	0.2	2.4	2.4	0.4	1.7	1.8
Unsig. Movement Delay, s/veh												
LnGrp Delay(d),s/veh	23.4	0.0	0.0	21.4	0.0	0.0	30.2	14.0	14.0	24.6	12.0	12.0
LnGrp LOS	C	A	A	C	A	A	C	B	B	C	B	B
Approach Vol, veh/h		45			161			705			601	
Approach Delay, s/veh		23.4			21.4			14.3			12.7	
Approach LOS		C			C			B			B	
Timer - Assigned Phs	1	2		4	5	6		8				
Phs Duration (G+Y+Rc), s	6.5	17.1		7.0	5.6	18.0		10.3				
Change Period (Y+Rc), s	5.0	5.0		5.0	5.0	5.0		5.0				
Max Green Setting (Gmax), s	5.0	19.0		18.0	5.0	19.0		18.0				
Max Q Clear Time (g_c+I1), s	2.7	9.0		3.0	2.3	7.2		5.7				
Green Ext Time (p_c), s	0.0	3.1		0.1	0.0	2.7		0.6				

Intersection Summary

HCM 6th Ctrl Delay	14.7
HCM 6th LOS	B

Intersection												
Int Delay, s/veh	7.7											
Movement	EBL	EBT	EBR	WBL	WBT	WBR	NBL	NBT	NBR	SBL	SBT	SBR
Lane Configurations		↕			↕			↕			↕	
Traffic Vol, veh/h	2	38	8	23	44	1	5	6	10	0	5	7
Future Vol, veh/h	2	38	8	23	44	1	5	6	10	0	5	7
Conflicting Peds, #/hr	0	0	0	0	0	0	0	0	0	0	0	0
Sign Control	Stop	Stop	Stop	Stop	Stop	Stop	Free	Free	Free	Free	Free	Free
RT Channelized	-	-	None	-	-	None	-	-	None	-	-	None
Storage Length	-	-	-	-	-	-	-	-	-	-	-	-
Veh in Median Storage, #	-	0	-	-	0	-	-	0	-	-	0	-
Grade, %	-	0	-	-	0	-	-	0	-	-	0	-
Peak Hour Factor	79	79	79	79	79	79	79	79	79	79	79	79
Heavy Vehicles, %	2	2	2	2	2	2	2	2	2	2	2	2
Mvmt Flow	3	48	10	29	56	1	6	8	13	0	6	9

Major/Minor	Minor2		Minor1		Major1			Major2				
Conflicting Flow All	66	44	11	67	42	15	15	0	0	21	0	0
Stage 1	11	11	-	27	27	-	-	-	-	-	-	-
Stage 2	55	33	-	40	15	-	-	-	-	-	-	-
Critical Hdwy	7.12	6.52	6.22	7.12	6.52	6.22	4.12	-	-	4.12	-	-
Critical Hdwy Stg 1	6.12	5.52	-	6.12	5.52	-	-	-	-	-	-	-
Critical Hdwy Stg 2	6.12	5.52	-	6.12	5.52	-	-	-	-	-	-	-
Follow-up Hdwy	3.518	4.018	3.318	3.518	4.018	3.318	2.218	-	-	2.218	-	-
Pot Cap-1 Maneuver	927	848	1070	926	850	1065	1603	-	-	1595	-	-
Stage 1	1010	886	-	990	873	-	-	-	-	-	-	-
Stage 2	957	868	-	975	883	-	-	-	-	-	-	-
Platoon blocked, %								-	-	-	-	-
Mov Cap-1 Maneuver	877	845	1070	875	847	1065	1603	-	-	1595	-	-
Mov Cap-2 Maneuver	877	845	-	875	847	-	-	-	-	-	-	-
Stage 1	1006	886	-	986	870	-	-	-	-	-	-	-
Stage 2	891	865	-	913	883	-	-	-	-	-	-	-

Approach	EB		WB		NB		SB	
HCM Control Delay, s	9.4		9.7		1.7		0	
HCM LOS	A		A					

Minor Lane/Major Mvmt	NBL	NBT	NBR	EBLn1	WBLn1	SBL	SBT	SBR
Capacity (veh/h)	1603	-	-	877	859	1595	-	-
HCM Lane V/C Ratio	0.004	-	-	0.069	0.1	-	-	-
HCM Control Delay (s)	7.3	0	-	9.4	9.7	0	-	-
HCM Lane LOS	A	A	-	A	A	A	-	-
HCM 95th %tile Q(veh)	0	-	-	0.2	0.3	0	-	-

Heritage at Dalia Ranch
6: Imperial Ave & Worthington Rd/Barioni Blvd

Opening Year 2023
Timing Plan: PM PEAK

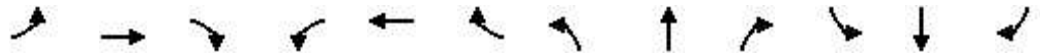

Movement	EBL	EBT	EBR	WBL	WBT	WBR	NBL	NBT	NBR	SBL	SBT	SBR
Lane Configurations		↖	↗		↖	↗	↖	↗	↖	↗	↖	↗
Traffic Volume (veh/h)	48	74	105	54	112	51	112	666	14	27	593	63
Future Volume (veh/h)	48	74	105	54	112	51	112	666	14	27	593	63
Initial Q (Qb), veh	0	0	0	0	0	0	0	0	0	0	0	0
Ped-Bike Adj(A_pbT)	1.00		1.00	1.00		1.00	1.00		1.00	1.00		1.00
Parking Bus, Adj	1.00	1.00	1.00	1.00	1.00	1.00	1.00	1.00	1.00	1.00	1.00	1.00
Work Zone On Approach		No			No			No			No	
Adj Sat Flow, veh/h/ln	1870	1870	1870	1870	1870	1870	1870	1870	1870	1870	1870	1870
Adj Flow Rate, veh/h	53	81	115	59	123	56	123	732	15	30	652	69
Peak Hour Factor	0.91	0.91	0.91	0.91	0.91	0.91	0.91	0.91	0.91	0.91	0.91	0.91
Percent Heavy Veh, %	2	2	2	2	2	2	2	2	2	2	2	2
Cap, veh/h	87	133	191	86	179	227	157	1147	24	60	868	92
Arrive On Green	0.12	0.12	0.12	0.14	0.14	0.14	0.09	0.32	0.32	0.03	0.27	0.27
Sat Flow, veh/h	725	1109	1585	597	1244	1585	1781	3561	73	1781	3243	343
Grp Volume(v), veh/h	134	0	115	182	0	56	123	365	382	30	357	364
Grp Sat Flow(s),veh/h/ln	1834	0	1585	1841	0	1585	1781	1777	1857	1781	1777	1809
Q Serve(g_s), s	3.6	0.0	3.6	4.9	0.0	1.6	3.6	9.2	9.2	0.9	9.7	9.7
Cycle Q Clear(g_c), s	3.6	0.0	3.6	4.9	0.0	1.6	3.6	9.2	9.2	0.9	9.7	9.7
Prop In Lane	0.40		1.00	0.32		1.00	1.00		0.04	1.00		0.19
Lane Grp Cap(c), veh/h	220	0	191	264	0	227	157	572	598	60	475	484
V/C Ratio(X)	0.61	0.00	0.60	0.69	0.00	0.25	0.78	0.64	0.64	0.50	0.75	0.75
Avail Cap(c_a), veh/h	628	0	543	630	0	543	203	642	671	169	608	619
HCM Platoon Ratio	1.00	1.00	1.00	1.00	1.00	1.00	1.00	1.00	1.00	1.00	1.00	1.00
Upstream Filter(l)	1.00	0.00	1.00	1.00	0.00	1.00	1.00	1.00	1.00	1.00	1.00	1.00
Uniform Delay (d), s/veh	22.0	0.0	21.9	21.4	0.0	20.0	23.5	15.2	15.2	25.0	17.6	17.7
Incr Delay (d2), s/veh	2.7	0.0	3.1	3.2	0.0	0.6	13.7	1.8	1.7	6.3	3.9	3.9
Initial Q Delay(d3),s/veh	0.0	0.0	0.0	0.0	0.0	0.0	0.0	0.0	0.0	0.0	0.0	0.0
%ile BackOfQ(50%),veh/ln	1.6	0.0	1.4	2.2	0.0	0.6	2.0	3.5	3.7	0.4	4.0	4.1
Unsig. Movement Delay, s/veh												
LnGrp Delay(d),s/veh	24.6	0.0	25.0	24.6	0.0	20.5	37.2	17.0	16.9	31.2	21.5	21.5
LnGrp LOS	C	A	C	C	A	C	D	B	B	C	C	C
Approach Vol, veh/h		249			238			870			751	
Approach Delay, s/veh		24.8			23.6			19.8			21.9	
Approach LOS		C			C			B			C	
Timer - Assigned Phs	1	2		4	5	6		8				
Phs Duration (G+Y+Rc), s	6.8	21.9		11.3	9.6	19.1		12.5				
Change Period (Y+Rc), s	5.0	5.0		5.0	5.0	5.0		5.0				
Max Green Setting (Gmax), s	5.0	19.0		18.0	6.0	18.0		18.0				
Max Q Clear Time (g_c+I1), s	2.9	11.2		5.6	5.6	11.7		6.9				
Green Ext Time (p_c), s	0.0	2.8		0.8	0.0	2.4		0.8				
Intersection Summary												
HCM 6th Ctrl Delay			21.6									
HCM 6th LOS			C									

Intersection												
Intersection Delay, s/veh	10.5											
Intersection LOS	B											

Movement	EBL	EBT	EBR	WBL	WBT	WBR	NBL	NBT	NBR	SBL	SBT	SBR
Lane Configurations		↔	↔		↔	↔		↔			↔	
Traffic Vol, veh/h	26	187	33	27	215	34	1	0	0	37	5	24
Future Vol, veh/h	26	187	33	27	215	34	1	0	0	37	5	24
Peak Hour Factor	0.80	0.80	0.80	0.80	0.80	0.80	0.80	0.80	0.80	0.80	0.80	0.80
Heavy Vehicles, %	2	2	2	2	2	2	2	2	2	2	2	2
Mvmt Flow	33	234	41	34	269	43	1	0	0	46	6	30
Number of Lanes	0	1	1	0	1	1	0	1	0	0	1	0

Approach	EB	WB	NB	SB
Opposing Approach	WB	EB	SB	NB
Opposing Lanes	2	2	1	1
Conflicting Approach Left	SB	NB	EB	WB
Conflicting Lanes Left	1	1	2	2
Conflicting Approach Right	NB	SB	WB	EB
Conflicting Lanes Right	1	1	2	2
HCM Control Delay	10.4	11	8.9	9.1
HCM LOS	B	B	A	A

Lane	NBLn1	EBLn1	EBLn2	WBLn1	WBLn2	SBLn1
Vol Left, %	100%	12%	0%	11%	0%	56%
Vol Thru, %	0%	88%	0%	89%	0%	8%
Vol Right, %	0%	0%	100%	0%	100%	36%
Sign Control	Stop	Stop	Stop	Stop	Stop	Stop
Traffic Vol by Lane	1	213	33	242	34	66
LT Vol	1	26	0	27	0	37
Through Vol	0	187	0	215	0	5
RT Vol	0	0	33	0	34	24
Lane Flow Rate	1	266	41	302	42	82
Geometry Grp	2	7	7	7	7	2
Degree of Util (X)	0.002	0.378	0.05	0.426	0.051	0.122
Departure Headway (Hd)	5.78	5.11	4.345	5.073	4.314	5.32
Convergence, Y/N	Yes	Yes	Yes	Yes	Yes	Yes
Cap	616	703	823	708	828	672
Service Time	3.847	2.846	2.08	2.809	2.049	3.368
HCM Lane V/C Ratio	0.002	0.378	0.05	0.427	0.051	0.122
HCM Control Delay	8.9	10.9	7.3	11.5	7.3	9.1
HCM Lane LOS	A	B	A	B	A	A
HCM 95th-tile Q	0	1.8	0.2	2.1	0.2	0.4

Heritage at Dalia Ranch
8: Imperial Ave & Aten Rd

Opening Year 2023
Timing Plan: PM PEAK



Movement	EBL	EBT	EBR	WBL	WBT	WBR	NBL	NBT	NBR	SBL	SBT	SBR
Lane Configurations												
Traffic Volume (veh/h)	189	276	68	178	288	122	78	664	149	112	538	209
Future Volume (veh/h)	189	276	68	178	288	122	78	664	149	112	538	209
Initial Q (Qb), veh	0	0	0	0	0	0	0	0	0	0	0	0
Ped-Bike Adj(A_pbT)	1.00		1.00	1.00		1.00	1.00		1.00	1.00		1.00
Parking Bus, Adj	1.00	1.00	1.00	1.00	1.00	1.00	1.00	1.00	1.00	1.00	1.00	1.00
Work Zone On Approach		No			No			No			No	
Adj Sat Flow, veh/h/ln	1870	1870	1870	1870	1870	1870	1870	1870	1870	1870	1870	1870
Adj Flow Rate, veh/h	201	294	72	189	306	130	83	706	159	119	572	222
Peak Hour Factor	0.94	0.94	0.94	0.94	0.94	0.94	0.94	0.94	0.94	0.94	0.94	0.94
Percent Heavy Veh, %	2	2	2	2	2	2	2	2	2	2	2	2
Cap, veh/h	249	536	129	236	445	185	111	927	413	152	1010	450
Arrive On Green	0.14	0.19	0.19	0.13	0.18	0.18	0.06	0.26	0.26	0.09	0.28	0.28
Sat Flow, veh/h	1781	2840	684	1781	2447	1017	1781	3554	1585	1781	3554	1585
Grp Volume(v), veh/h	201	182	184	189	220	216	83	706	159	119	572	222
Grp Sat Flow(s),veh/h/ln	1781	1777	1747	1781	1777	1687	1781	1777	1585	1781	1777	1585
Q Serve(g_s), s	6.6	5.6	5.7	6.2	7.0	7.2	2.8	11.0	5.0	3.9	8.3	7.0
Cycle Q Clear(g_c), s	6.6	5.6	5.7	6.2	7.0	7.2	2.8	11.0	5.0	3.9	8.3	7.0
Prop In Lane	1.00		0.39	1.00		0.60	1.00		1.00	1.00		1.00
Lane Grp Cap(c), veh/h	249	336	330	236	323	307	111	927	413	152	1010	450
V/C Ratio(X)	0.81	0.54	0.56	0.80	0.68	0.70	0.75	0.76	0.38	0.78	0.57	0.49
Avail Cap(c_a), veh/h	325	531	522	325	531	504	177	1121	500	207	1180	526
HCM Platoon Ratio	1.00	1.00	1.00	1.00	1.00	1.00	1.00	1.00	1.00	1.00	1.00	1.00
Upstream Filter(l)	1.00	1.00	1.00	1.00	1.00	1.00	1.00	1.00	1.00	1.00	1.00	1.00
Uniform Delay (d), s/veh	25.1	22.1	22.1	25.3	23.0	23.1	27.8	20.5	18.3	27.0	18.4	17.9
Incr Delay (d2), s/veh	10.8	1.4	1.5	9.5	2.5	2.9	9.6	2.5	0.6	12.4	0.5	0.8
Initial Q Delay(d3),s/veh	0.0	0.0	0.0	0.0	0.0	0.0	0.0	0.0	0.0	0.0	0.0	0.0
%ile BackOfQ(50%),veh/ln	3.4	2.3	2.3	3.1	2.9	2.9	1.4	4.5	1.7	2.1	3.2	2.4
Unsig. Movement Delay, s/veh												
LnGrp Delay(d),s/veh	35.9	23.4	23.6	34.8	25.6	26.1	37.4	23.1	18.9	39.4	18.9	18.8
LnGrp LOS	D	C	C	C	C	C	D	C	B	D	B	B
Approach Vol, veh/h		567			625			948			913	
Approach Delay, s/veh		27.9			28.5			23.6			21.5	
Approach LOS		C			C			C			C	
Timer - Assigned Phs	1	2	3	4	5	6	7	8				
Phs Duration (G+Y+Rc), s	20.2	20.7	13.0	16.4	8.8	22.1	13.4	15.9				
Change Period (Y+Rc), s	5.0	5.0	5.0	5.0	5.0	5.0	5.0	5.0				
Max Green Setting (Gmax), s	19.0	19.0	11.0	18.0	6.0	20.0	11.0	18.0				
Max Q Clear Time (g_c+1/3), s	13.0	13.0	8.2	7.7	4.8	10.3	8.6	9.2				
Green Ext Time (p_c), s	0.0	2.7	0.1	1.5	0.0	3.3	0.1	1.7				
Intersection Summary												
HCM 6th Ctrl Delay											24.8	
HCM 6th LOS											C	

Heritage at Dalia Ranch
1: SR-86 & Keystone Rd

Opening Year 2023 + P1 Proj
Timing Plan: AM PEAK

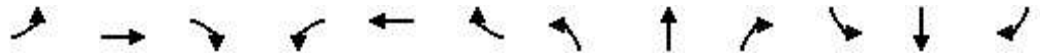

Movement	EBL	EBT	EBR	WBL	WBT	WBR	NBL	NBT	NBR	SBL	SBT	SBR
Lane Configurations		↕			↕		↕	↕↕	↕	↕	↕↕	↕
Traffic Volume (veh/h)	33	33	11	19	24	42	19	454	49	45	517	37
Future Volume (veh/h)	33	33	11	19	24	42	19	454	49	45	517	37
Initial Q (Qb), veh	0	0	0	0	0	0	0	0	0	0	0	0
Ped-Bike Adj(A_pbT)	1.00		1.00	1.00		1.00	1.00		1.00	1.00		1.00
Parking Bus, Adj	1.00	1.00	1.00	1.00	1.00	1.00	1.00	1.00	1.00	1.00	1.00	1.00
Work Zone On Approach		No			No			No			No	
Adj Sat Flow, veh/h/ln	1870	1870	1870	1870	1870	1870	1870	1870	1870	1870	1870	1870
Adj Flow Rate, veh/h	37	37	12	21	27	47	21	504	54	50	574	41
Peak Hour Factor	0.90	0.90	0.90	0.90	0.90	0.90	0.90	0.90	0.90	0.90	0.90	0.90
Percent Heavy Veh, %	2	2	2	2	2	2	2	2	2	2	2	2
Cap, veh/h	259	110	31	190	74	108	48	1021	455	102	1129	503
Arrive On Green	0.13	0.13	0.13	0.13	0.13	0.13	0.03	0.29	0.29	0.06	0.32	0.32
Sat Flow, veh/h	598	830	232	276	556	814	1781	3554	1585	1781	3554	1585
Grp Volume(v), veh/h	86	0	0	95	0	0	21	504	54	50	574	41
Grp Sat Flow(s),veh/h/ln	1659	0	0	1646	0	0	1781	1777	1585	1781	1777	1585
Q Serve(g_s), s	0.0	0.0	0.0	0.2	0.0	0.0	0.3	3.4	0.7	0.8	3.8	0.5
Cycle Q Clear(g_c), s	1.2	0.0	0.0	1.4	0.0	0.0	0.3	3.4	0.7	0.8	3.8	0.5
Prop In Lane	0.43		0.14	0.22		0.49	1.00		1.00	1.00		1.00
Lane Grp Cap(c), veh/h	400	0	0	372	0	0	48	1021	455	102	1129	503
V/C Ratio(X)	0.21	0.00	0.00	0.26	0.00	0.00	0.44	0.49	0.12	0.49	0.51	0.08
Avail Cap(c_a), veh/h	1169	0	0	1160	0	0	310	2228	994	310	2228	994
HCM Platoon Ratio	1.00	1.00	1.00	1.00	1.00	1.00	1.00	1.00	1.00	1.00	1.00	1.00
Upstream Filter(l)	1.00	0.00	0.00	1.00	0.00	0.00	1.00	1.00	1.00	1.00	1.00	1.00
Uniform Delay (d), s/veh	11.3	0.0	0.0	11.4	0.0	0.0	13.8	8.5	7.6	13.1	8.0	6.9
Incr Delay (d2), s/veh	0.3	0.0	0.0	0.4	0.0	0.0	6.2	0.4	0.1	3.6	0.4	0.1
Initial Q Delay(d3),s/veh	0.0	0.0	0.0	0.0	0.0	0.0	0.0	0.0	0.0	0.0	0.0	0.0
%ile BackOfQ(50%),veh/ln	0.4	0.0	0.0	0.4	0.0	0.0	0.2	0.9	0.2	0.3	0.9	0.1
Unsig. Movement Delay, s/veh												
LnGrp Delay(d),s/veh	11.6	0.0	0.0	11.8	0.0	0.0	20.0	8.9	7.7	16.7	8.3	6.9
LnGrp LOS	B	A	A	B	A	A	B	A	A	B	A	A
Approach Vol, veh/h		86			95			579			665	
Approach Delay, s/veh		11.6			11.8			9.2			8.9	
Approach LOS		B			B			A			A	
Timer - Assigned Phs	1	2		4	5	6		8				
Phs Duration (G+Y+Rc), s	6.6	13.2		8.8	5.8	14.1		8.8				
Change Period (Y+Rc), s	5.0	5.0		5.0	5.0	5.0		5.0				
Max Green Setting (Gmax), s	5.0	18.0		18.0	5.0	18.0		18.0				
Max Q Clear Time (g_c+I1), s	2.8	5.4		3.2	2.3	5.8		3.4				
Green Ext Time (p_c), s	0.0	2.9		0.3	0.0	3.2		0.4				
Intersection Summary												
HCM 6th Ctrl Delay				9.3								
HCM 6th LOS				A								

Intersection												
Int Delay, s/veh	0.4											
Movement	EBL	EBT	EBR	WBL	WBT	WBR	NBL	NBT	NBR	SBL	SBT	SBR
Lane Configurations		↕			↕		↕	↕		↕	↕	
Traffic Vol, veh/h	20	3	2	1	2	5	0	521	1	1	522	7
Future Vol, veh/h	20	3	2	1	2	5	0	521	1	1	522	7
Conflicting Peds, #/hr	0	0	0	0	0	0	0	0	0	0	0	0
Sign Control	Stop	Stop	Stop	Stop	Stop	Stop	Free	Free	Free	Free	Free	Free
RT Channelized	-	-	None	-	-	None	-	-	None	-	-	None
Storage Length	-	-	-	-	-	-	50	-	-	50	-	-
Veh in Median Storage, #	-	1	-	-	1	-	-	0	-	-	0	-
Grade, %	-	0	-	-	0	-	-	0	-	-	0	-
Peak Hour Factor	94	94	94	94	94	94	94	94	94	94	94	94
Heavy Vehicles, %	2	2	2	2	2	2	2	2	2	2	2	2
Mvmt Flow	21	3	2	1	2	5	0	554	1	1	555	7

Major/Minor	Minor2		Minor1		Major1			Major2				
Conflicting Flow All	839	1116	281	836	1119	278	562	0	0	555	0	0
Stage 1	561	561	-	555	555	-	-	-	-	-	-	-
Stage 2	278	555	-	281	564	-	-	-	-	-	-	-
Critical Hdwy	7.54	6.54	6.94	7.54	6.54	6.94	4.14	-	-	4.14	-	-
Critical Hdwy Stg 1	6.54	5.54	-	6.54	5.54	-	-	-	-	-	-	-
Critical Hdwy Stg 2	6.54	5.54	-	6.54	5.54	-	-	-	-	-	-	-
Follow-up Hdwy	3.52	4.02	3.32	3.52	4.02	3.32	2.22	-	-	2.22	-	-
Pot Cap-1 Maneuver	259	206	716	260	205	719	1005	-	-	1011	-	-
Stage 1	480	508	-	484	511	-	-	-	-	-	-	-
Stage 2	705	511	-	702	507	-	-	-	-	-	-	-
Platoon blocked, %								-	-	-	-	-
Mov Cap-1 Maneuver	256	206	716	257	205	719	1005	-	-	1011	-	-
Mov Cap-2 Maneuver	369	326	-	371	326	-	-	-	-	-	-	-
Stage 1	480	507	-	484	511	-	-	-	-	-	-	-
Stage 2	697	511	-	695	506	-	-	-	-	-	-	-

Approach	EB		WB		NB		SB	
HCM Control Delay, s	15.2		12.2		0		0	
HCM LOS	C		B					

Minor Lane/Major Mvmt	NBL	NBT	NBR	EBLn1	WBLn1	SBL	SBT	SBR
Capacity (veh/h)	1005	-	-	378	507	1011	-	-
HCM Lane V/C Ratio	-	-	-	0.07	0.017	0.001	-	-
HCM Control Delay (s)	0	-	-	15.2	12.2	8.6	-	-
HCM Lane LOS	A	-	-	C	B	A	-	-
HCM 95th %tile Q(veh)	0	-	-	0.2	0.1	0	-	-

Intersection						
Int Delay, s/veh	1.6					
Movement	WBL	WBR	NBT	NBR	SBL	SBT
Lane Configurations	TT		TT		T	TT
Traffic Vol, veh/h	59	23	499	41	20	505
Future Vol, veh/h	59	23	499	41	20	505
Conflicting Peds, #/hr	0	0	0	0	0	0
Sign Control	Stop	Stop	Free	Free	Free	Free
RT Channelized	-	None	-	None	-	None
Storage Length	0	-	-	-	140	-
Veh in Median Storage, #	0	-	0	-	-	0
Grade, %	0	-	0	-	-	0
Peak Hour Factor	91	91	91	91	91	91
Heavy Vehicles, %	2	2	2	2	2	2
Mvmt Flow	65	25	548	45	22	555

Major/Minor	Minor1	Major1	Major2		
Conflicting Flow All	893	297	0	0	593
Stage 1	571	-	-	-	-
Stage 2	322	-	-	-	-
Critical Hdwy	6.84	6.94	-	-	4.14
Critical Hdwy Stg 1	5.84	-	-	-	-
Critical Hdwy Stg 2	5.84	-	-	-	-
Follow-up Hdwy	3.52	3.32	-	-	2.22
Pot Cap-1 Maneuver	281	699	-	-	979
Stage 1	529	-	-	-	-
Stage 2	707	-	-	-	-
Platoon blocked, %			-	-	-
Mov Cap-1 Maneuver	275	699	-	-	979
Mov Cap-2 Maneuver	275	-	-	-	-
Stage 1	529	-	-	-	-
Stage 2	691	-	-	-	-

Approach	WB	NB	SB
HCM Control Delay, s	19.9	0	0.3
HCM LOS	C		

Minor Lane/Major Mvmt	NBT	NBRWBLn1	SBL	SBT
Capacity (veh/h)	-	-	331	979
HCM Lane V/C Ratio	-	-	0.272	0.022
HCM Control Delay (s)	-	-	19.9	8.8
HCM Lane LOS	-	-	C	A
HCM 95th %tile Q(veh)	-	-	1.1	0.1

Heritage at Dalia Ranch
4: Imperial Ave & Neckel Rd

Opening Year 2023 + P1 Proj
Timing Plan: AM PEAK

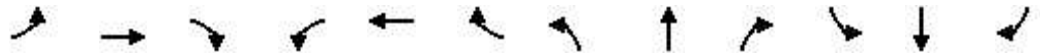

Movement	EBL	EBT	EBR	WBL	WBT	WBR	NBL	NBT	NBR	SBL	SBT	SBR
Lane Configurations		↕			↕		↕	↕		↕	↕	
Traffic Volume (veh/h)	49	43	64	142	64	56	26	442	65	14	511	36
Future Volume (veh/h)	49	43	64	142	64	56	26	442	65	14	511	36
Initial Q (Qb), veh	0	0	0	0	0	0	0	0	0	0	0	0
Ped-Bike Adj(A_pbT)	1.00		1.00	1.00		1.00	1.00		1.00	1.00		1.00
Parking Bus, Adj	1.00	1.00	1.00	1.00	1.00	1.00	1.00	1.00	1.00	1.00	1.00	1.00
Work Zone On Approach		No			No			No			No	
Adj Sat Flow, veh/h/ln	1870	1870	1870	1870	1870	1870	1870	1870	1870	1870	1870	1870
Adj Flow Rate, veh/h	54	47	70	156	70	62	29	486	71	15	562	40
Peak Hour Factor	0.91	0.91	0.91	0.91	0.91	0.91	0.91	0.91	0.91	0.91	0.91	0.91
Percent Heavy Veh, %	2	2	2	2	2	2	2	2	2	2	2	2
Cap, veh/h	73	63	94	199	89	79	59	788	115	33	804	57
Arrive On Green	0.13	0.13	0.13	0.21	0.21	0.21	0.03	0.25	0.25	0.02	0.24	0.24
Sat Flow, veh/h	542	472	703	951	427	378	1781	3113	453	1781	3365	239
Grp Volume(v), veh/h	171	0	0	288	0	0	29	276	281	15	296	306
Grp Sat Flow(s),veh/h/ln	1717	0	0	1755	0	0	1781	1777	1789	1781	1777	1827
Q Serve(g_s), s	5.0	0.0	0.0	8.1	0.0	0.0	0.8	7.2	7.2	0.4	7.9	8.0
Cycle Q Clear(g_c), s	5.0	0.0	0.0	8.1	0.0	0.0	0.8	7.2	7.2	0.4	7.9	8.0
Prop In Lane	0.32		0.41	0.54		0.22	1.00		0.25	1.00		0.13
Lane Grp Cap(c), veh/h	231	0	0	368	0	0	59	450	453	33	424	436
V/C Ratio(X)	0.74	0.00	0.00	0.78	0.00	0.00	0.49	0.61	0.62	0.45	0.70	0.70
Avail Cap(c_a), veh/h	593	0	0	607	0	0	171	648	653	171	648	667
HCM Platoon Ratio	1.00	1.00	1.00	1.00	1.00	1.00	1.00	1.00	1.00	1.00	1.00	1.00
Upstream Filter(l)	1.00	0.00	0.00	1.00	0.00	0.00	1.00	1.00	1.00	1.00	1.00	1.00
Uniform Delay (d), s/veh	21.7	0.0	0.0	19.4	0.0	0.0	24.8	17.2	17.2	25.3	18.1	18.1
Incr Delay (d2), s/veh	4.7	0.0	0.0	3.7	0.0	0.0	6.3	1.4	1.4	9.2	2.1	2.1
Initial Q Delay(d3),s/veh	0.0	0.0	0.0	0.0	0.0	0.0	0.0	0.0	0.0	0.0	0.0	0.0
%ile BackOfQ(50%),veh/ln	2.1	0.0	0.0	3.3	0.0	0.0	0.4	2.8	2.8	0.3	3.1	3.2
Unsig. Movement Delay, s/veh												
LnGrp Delay(d),s/veh	26.3	0.0	0.0	23.1	0.0	0.0	31.1	18.6	18.6	34.5	20.2	20.2
LnGrp LOS	C	A	A	C	A	A	C	B	B	C	C	C
Approach Vol, veh/h		171			288			586			617	
Approach Delay, s/veh		26.3			23.1			19.2			20.5	
Approach LOS		C			C			B			C	
Timer - Assigned Phs	1	2		4	5	6		8				
Phs Duration (G+Y+Rc), s	6.0	18.2		12.0	6.7	17.4		15.9				
Change Period (Y+Rc), s	5.0	5.0		5.0	5.0	5.0		5.0				
Max Green Setting (Gmax), s	5.0	19.0		18.0	5.0	19.0		18.0				
Max Q Clear Time (g_c+I1), s	2.4	9.2		7.0	2.8	10.0		10.1				
Green Ext Time (p_c), s	0.0	2.4		0.6	0.0	2.5		1.0				
Intersection Summary												
HCM 6th Ctrl Delay				21.1								
HCM 6th LOS				C								

Intersection												
Int Delay, s/veh	7.7											
Movement	EBL	EBT	EBR	WBL	WBT	WBR	NBL	NBT	NBR	SBL	SBT	SBR
Lane Configurations		↕			↕			↕			↕	
Traffic Vol, veh/h	4	41	23	67	44	0	7	6	45	1	2	1
Future Vol, veh/h	4	41	23	67	44	0	7	6	45	1	2	1
Conflicting Peds, #/hr	0	0	0	0	0	0	0	0	0	0	0	0
Sign Control	Stop	Stop	Stop	Stop	Stop	Stop	Free	Free	Free	Free	Free	Free
RT Channelized	-	-	None	-	-	None	-	-	None	-	-	None
Storage Length	-	-	-	-	-	-	-	-	-	-	-	-
Veh in Median Storage, #	-	0	-	-	0	-	-	0	-	-	0	-
Grade, %	-	0	-	-	0	-	-	0	-	-	0	-
Peak Hour Factor	79	79	79	79	79	79	79	79	79	79	79	79
Heavy Vehicles, %	2	2	2	2	2	2	2	2	2	2	2	2
Mvmt Flow	5	52	29	85	56	0	9	8	57	1	3	1

Major/Minor	Minor2		Minor1		Major1			Major2				
Conflicting Flow All	89	89	4	101	61	37	4	0	0	65	0	0
Stage 1	6	6	-	55	55	-	-	-	-	-	-	-
Stage 2	83	83	-	46	6	-	-	-	-	-	-	-
Critical Hdwy	7.12	6.52	6.22	7.12	6.52	6.22	4.12	-	-	4.12	-	-
Critical Hdwy Stg 1	6.12	5.52	-	6.12	5.52	-	-	-	-	-	-	-
Critical Hdwy Stg 2	6.12	5.52	-	6.12	5.52	-	-	-	-	-	-	-
Follow-up Hdwy	3.518	4.018	3.318	3.518	4.018	3.318	2.218	-	-	2.218	-	-
Pot Cap-1 Maneuver	896	801	1080	880	830	1035	1618	-	-	1537	-	-
Stage 1	1016	891	-	957	849	-	-	-	-	-	-	-
Stage 2	925	826	-	968	891	-	-	-	-	-	-	-
Platoon blocked, %								-	-	-	-	-
Mov Cap-1 Maneuver	845	795	1080	810	824	1035	1618	-	-	1537	-	-
Mov Cap-2 Maneuver	845	795	-	810	824	-	-	-	-	-	-	-
Stage 1	1010	890	-	951	844	-	-	-	-	-	-	-
Stage 2	859	821	-	886	890	-	-	-	-	-	-	-

Approach	EB		WB		NB		SB	
HCM Control Delay, s	9.6		10.3		0.9		1.8	
HCM LOS	A		B					

Minor Lane/Major Mvmt	NBL	NBT	NBR	EBLn1	WBLn1	SBL	SBT	SBR
Capacity (veh/h)	1618	-	-	876	815	1537	-	-
HCM Lane V/C Ratio	0.005	-	-	0.098	0.172	0.001	-	-
HCM Control Delay (s)	7.2	0	-	9.6	10.3	7.3	0	-
HCM Lane LOS	A	A	-	A	B	A	A	-
HCM 95th %tile Q(veh)	0	-	-	0.3	0.6	0	-	-

Heritage at Dalia Ranch
6: Imperial Ave & Worthington Rd/Barioni Blvd

Opening Year 2023 + P1 Proj
Timing Plan: AM PEAK



Movement	EBL	EBT	EBR	WBL	WBT	WBR	NBL	NBT	NBR	SBL	SBT	SBR
Lane Configurations		↕	↗		↕	↗	↖	↕↗		↖	↕↗	
Traffic Volume (veh/h)	70	136	212	54	132	80	93	480	50	46	674	56
Future Volume (veh/h)	70	136	212	54	132	80	93	480	50	46	674	56
Initial Q (Qb), veh	0	0	0	0	0	0	0	0	0	0	0	0
Ped-Bike Adj(A_pbT)	1.00		1.00	1.00		1.00	1.00		1.00	1.00		1.00
Parking Bus, Adj	1.00	1.00	1.00	1.00	1.00	1.00	1.00	1.00	1.00	1.00	1.00	1.00
Work Zone On Approach		No			No			No			No	
Adj Sat Flow, veh/h/ln	1870	1870	1870	1870	1870	1870	1870	1870	1870	1870	1870	1870
Adj Flow Rate, veh/h	79	153	238	61	148	90	104	539	56	52	757	63
Peak Hour Factor	0.89	0.89	0.89	0.89	0.89	0.89	0.89	0.89	0.89	0.89	0.89	0.89
Percent Heavy Veh, %	2	2	2	2	2	2	2	2	2	2	2	2
Cap, veh/h	121	234	306	83	200	243	133	967	100	84	896	75
Arrive On Green	0.19	0.19	0.19	0.15	0.15	0.15	0.07	0.30	0.30	0.05	0.27	0.27
Sat Flow, veh/h	626	1213	1585	538	1305	1585	1781	3250	337	1781	3321	276
Grp Volume(v), veh/h	232	0	238	209	0	90	104	294	301	52	405	415
Grp Sat Flow(s),veh/h/ln	1839	0	1585	1843	0	1585	1781	1777	1810	1781	1777	1821
Q Serve(g_s), s	7.5	0.0	9.2	7.0	0.0	3.3	3.7	9.0	9.1	1.9	13.9	13.9
Cycle Q Clear(g_c), s	7.5	0.0	9.2	7.0	0.0	3.3	3.7	9.0	9.1	1.9	13.9	13.9
Prop In Lane	0.34		1.00	0.29		1.00	1.00		0.19	1.00		0.15
Lane Grp Cap(c), veh/h	355	0	306	283	0	243	133	528	538	84	479	491
V/C Ratio(X)	0.65	0.00	0.78	0.74	0.00	0.37	0.78	0.56	0.56	0.62	0.84	0.85
Avail Cap(c_a), veh/h	512	0	441	513	0	441	138	528	538	138	522	535
HCM Platoon Ratio	1.00	1.00	1.00	1.00	1.00	1.00	1.00	1.00	1.00	1.00	1.00	1.00
Upstream Filter(l)	1.00	0.00	1.00	1.00	0.00	1.00	1.00	1.00	1.00	1.00	1.00	1.00
Uniform Delay (d), s/veh	24.1	0.0	24.8	26.1	0.0	24.6	29.4	19.1	19.1	30.2	22.3	22.3
Incr Delay (d2), s/veh	2.0	0.0	5.4	3.8	0.0	0.9	24.0	1.3	1.3	7.3	11.4	11.2
Initial Q Delay(d3),s/veh	0.0	0.0	0.0	0.0	0.0	0.0	0.0	0.0	0.0	0.0	0.0	0.0
%ile BackOfQ(50%),veh/ln	3.3	0.0	3.7	3.2	0.0	1.2	2.4	3.6	3.7	0.9	6.9	7.0
Unsig. Movement Delay, s/veh												
LnGrp Delay(d),s/veh	26.1	0.0	30.2	29.9	0.0	25.5	53.4	20.4	20.4	37.6	33.7	33.5
LnGrp LOS	C	A	C	C	A	C	D	C	C	D	C	C
Approach Vol, veh/h		470			299			699				872
Approach Delay, s/veh		28.2			28.6			25.3				33.9
Approach LOS		C			C			C				C
Timer - Assigned Phs	1	2		4	5	6		8				
Phs Duration (G+Y+Rc), s	8.0	24.2		17.5	9.8	22.4		14.9				
Change Period (Y+Rc), s	5.0	5.0		5.0	5.0	5.0		5.0				
Max Green Setting (Gmax), s	5.0	19.0		18.0	5.0	19.0		18.0				
Max Q Clear Time (g_c+I1), s	3.9	11.1		11.2	5.7	15.9		9.0				
Green Ext Time (p_c), s	0.0	2.3		1.3	0.0	1.5		1.0				
Intersection Summary												
HCM 6th Ctrl Delay				29.5								
HCM 6th LOS				C								

Intersection

Intersection Delay, s/veh 19.8

Intersection LOS C

Movement	EBL	EBT	EBR	WBL	WBT	WBR	NBL	NBT	NBR	SBL	SBT	SBR
Lane Configurations		↔	↔		↔	↔		↔			↔	
Traffic Vol, veh/h	64	390	119	11	301	77	0	0	1	106	31	71
Future Vol, veh/h	64	390	119	11	301	77	0	0	1	106	31	71
Peak Hour Factor	0.92	0.92	0.92	0.92	0.92	0.92	0.92	0.92	0.92	0.92	0.92	0.92
Heavy Vehicles, %	2	2	2	2	2	2	2	2	2	2	2	2
Mvmt Flow	70	424	129	12	327	84	0	0	1	115	34	77
Number of Lanes	0	1	1	0	1	1	0	1	0	0	1	0

Approach	EB	WB	NB	SB
Opposing Approach	WB	EB	SB	NB
Opposing Lanes	2	2	1	1
Conflicting Approach Left	SB	NB	EB	WB
Conflicting Lanes Left	1	1	2	2
Conflicting Approach Right	NB	SB	WB	EB
Conflicting Lanes Right	1	1	2	2
HCM Control Delay	25.2	15.3	9.6	13.4
HCM LOS	D	C	A	B

Lane	NBLn1	EBLn1	EBLn2	WBLn1	WBLn2	SBLn1
Vol Left, %	0%	14%	0%	4%	0%	51%
Vol Thru, %	0%	86%	0%	96%	0%	15%
Vol Right, %	100%	0%	100%	0%	100%	34%
Sign Control	Stop	Stop	Stop	Stop	Stop	Stop
Traffic Vol by Lane	1	454	119	312	77	208
LT Vol	0	64	0	11	0	106
Through Vol	0	390	0	301	0	31
RT Vol	1	0	119	0	77	71
Lane Flow Rate	1	493	129	339	84	226
Geometry Grp	2	7	7	7	7	2
Degree of Util (X)	0.002	0.812	0.185	0.575	0.125	0.394
Departure Headway (Hd)	6.515	5.923	5.142	6.105	5.376	6.274
Convergence, Y/N	Yes	Yes	Yes	Yes	Yes	Yes
Cap	545	612	696	590	665	572
Service Time	4.607	3.667	2.885	3.856	3.127	4.328
HCM Lane V/C Ratio	0.002	0.806	0.185	0.575	0.126	0.395
HCM Control Delay	9.6	29.4	9.1	16.9	8.9	13.4
HCM Lane LOS	A	D	A	C	A	B
HCM 95th-tile Q	0	8.2	0.7	3.6	0.4	1.9

Heritage at Dalia Ranch
8: Imperial Ave & Aten Rd

Opening Year 2023 + P1 Proj
Timing Plan: AM PEAK



Movement	EBL	EBT	EBR	WBL	WBT	WBR	NBL	NBT	NBR	SBL	SBT	SBR
Lane Configurations												
Traffic Volume (veh/h)	189	337	63	131	299	144	61	353	67	149	700	382
Future Volume (veh/h)	189	337	63	131	299	144	61	353	67	149	700	382
Initial Q (Qb), veh	0	0	0	0	0	0	0	0	0	0	0	0
Ped-Bike Adj(A_pbT)	1.00		1.00	1.00		1.00	1.00		1.00	1.00		1.00
Parking Bus, Adj	1.00	1.00	1.00	1.00	1.00	1.00	1.00	1.00	1.00	1.00	1.00	1.00
Work Zone On Approach		No			No			No			No	
Adj Sat Flow, veh/h/ln	1870	1870	1870	1870	1870	1870	1870	1870	1870	1870	1870	1870
Adj Flow Rate, veh/h	220	392	73	152	348	167	71	410	78	173	814	444
Peak Hour Factor	0.86	0.86	0.86	0.86	0.86	0.86	0.86	0.86	0.86	0.86	0.86	0.86
Percent Heavy Veh, %	2	2	2	2	2	2	2	2	2	2	2	2
Cap, veh/h	259	704	130	190	460	217	96	890	397	208	1112	496
Arrive On Green	0.15	0.23	0.23	0.11	0.20	0.20	0.05	0.25	0.25	0.12	0.31	0.31
Sat Flow, veh/h	1781	2995	553	1781	2344	1105	1781	3554	1585	1781	3554	1585
Grp Volume(v), veh/h	220	231	234	152	262	253	71	410	78	173	814	444
Grp Sat Flow(s),veh/h/ln	1781	1777	1771	1781	1777	1672	1781	1777	1585	1781	1777	1585
Q Serve(g_s), s	8.3	7.9	8.0	5.7	9.6	9.8	2.7	6.7	2.7	6.5	14.0	18.4
Cycle Q Clear(g_c), s	8.3	7.9	8.0	5.7	9.6	9.8	2.7	6.7	2.7	6.5	14.0	18.4
Prop In Lane	1.00		0.31	1.00		0.66	1.00		1.00	1.00		1.00
Lane Grp Cap(c), veh/h	259	417	416	190	349	328	96	890	397	208	1112	496
V/C Ratio(X)	0.85	0.55	0.56	0.80	0.75	0.77	0.74	0.46	0.20	0.83	0.73	0.90
Avail Cap(c_a), veh/h	259	492	490	233	466	438	130	983	439	208	1139	508
HCM Platoon Ratio	1.00	1.00	1.00	1.00	1.00	1.00	1.00	1.00	1.00	1.00	1.00	1.00
Upstream Filter(l)	1.00	1.00	1.00	1.00	1.00	1.00	1.00	1.00	1.00	1.00	1.00	1.00
Uniform Delay (d), s/veh	28.6	23.1	23.2	29.9	26.0	26.1	32.0	21.8	20.3	29.7	21.0	22.5
Incr Delay (d2), s/veh	22.3	1.1	1.2	14.6	4.7	5.9	13.7	0.4	0.2	24.3	2.4	18.0
Initial Q Delay(d3),s/veh	0.0	0.0	0.0	0.0	0.0	0.0	0.0	0.0	0.0	0.0	0.0	0.0
%ile BackOfQ(50%),veh/ln	5.0	3.2	3.3	3.1	4.3	4.2	1.5	2.7	1.0	4.1	5.8	8.8
Unsig. Movement Delay, s/veh												
LnGrp Delay(d),s/veh	50.8	24.2	24.3	44.5	30.8	32.0	45.7	22.2	20.5	53.9	23.4	40.6
LnGrp LOS	D	C	C	D	C	C	D	C	C	D	C	D
Approach Vol, veh/h		685			667			559			1431	
Approach Delay, s/veh		32.8			34.4			24.9			32.4	
Approach LOS		C			C			C			C	
Timer - Assigned Phs	1	2	3	4	5	6	7	8				
Phs Duration (G+Y+Rc), s	3.0	22.2	12.3	21.1	8.7	26.5	15.0	18.5				
Change Period (Y+Rc), s	5.0	5.0	5.0	5.0	5.0	5.0	5.0	5.0				
Max Green Setting (Gmax), s	3.0	19.0	9.0	19.0	5.0	22.0	10.0	18.0				
Max Q Clear Time (g_c+1/3), s	3.0	8.7	7.7	10.0	4.7	20.4	10.3	11.8				
Green Ext Time (p_c), s	0.0	2.1	0.0	1.9	0.0	1.1	0.0	1.6				
Intersection Summary												
HCM 6th Ctrl Delay											31.6	
HCM 6th LOS											C	

Intersection						
Int Delay, s/veh	2.6					
Movement	EBL	EBT	WBT	WBR	SBL	SBR
Lane Configurations	↖	↗	↖		↖	↗
Traffic Vol, veh/h	3	89	103	23	67	7
Future Vol, veh/h	3	89	103	23	67	7
Conflicting Peds, #/hr	0	0	0	0	0	0
Sign Control	Free	Free	Free	Free	Stop	Stop
RT Channelized	-	None	-	None	-	None
Storage Length	50	-	-	-	0	0
Veh in Median Storage, #	-	0	0	-	0	-
Grade, %	-	0	0	-	0	-
Peak Hour Factor	92	92	92	92	92	92
Heavy Vehicles, %	2	2	2	2	2	2
Mvmt Flow	3	97	112	25	73	8

Major/Minor	Major1	Major2	Minor2		
Conflicting Flow All	137	0	-	0	228
Stage 1	-	-	-	-	125
Stage 2	-	-	-	-	103
Critical Hdwy	4.12	-	-	-	6.42
Critical Hdwy Stg 1	-	-	-	-	5.42
Critical Hdwy Stg 2	-	-	-	-	5.42
Follow-up Hdwy	2.218	-	-	-	3.518
Pot Cap-1 Maneuver	1447	-	-	-	760
Stage 1	-	-	-	-	901
Stage 2	-	-	-	-	921
Platoon blocked, %		-	-	-	
Mov Cap-1 Maneuver	1447	-	-	-	758
Mov Cap-2 Maneuver	-	-	-	-	758
Stage 1	-	-	-	-	899
Stage 2	-	-	-	-	921

Approach	EB	WB	SB
HCM Control Delay, s	0.2	0	10.2
HCM LOS			B

Minor Lane/Major Mvmt	EBL	EBT	WBT	WBR	SBLn1	SBLn2
Capacity (veh/h)	1447	-	-	-	758	926
HCM Lane V/C Ratio	0.002	-	-	-	0.096	0.008
HCM Control Delay (s)	7.5	-	-	-	10.3	8.9
HCM Lane LOS	A	-	-	-	B	A
HCM 95th %tile Q(veh)	0	-	-	-	0.3	0

Heritage at Dalia Ranch
1: SR-86 & Keystone Rd

Opening Year 2023 + P1 Proj
Timing Plan: PM PEAK

Movement	EBL	EBT	EBR	WBL	WBT	WBR	NBL	NBT	NBR	SBL	SBT	SBR
Lane Configurations												
Traffic Volume (veh/h)	41	12	20	33	27	37	10	533	26	52	559	34
Future Volume (veh/h)	41	12	20	33	27	37	10	533	26	52	559	34
Initial Q (Qb), veh	0	0	0	0	0	0	0	0	0	0	0	0
Ped-Bike Adj(A_pbT)	1.00		1.00	1.00		1.00	1.00		1.00	1.00		1.00
Parking Bus, Adj	1.00	1.00	1.00	1.00	1.00	1.00	1.00	1.00	1.00	1.00	1.00	1.00
Work Zone On Approach		No			No			No			No	
Adj Sat Flow, veh/h/ln	1870	1870	1870	1870	1870	1870	1870	1870	1870	1870	1870	1870
Adj Flow Rate, veh/h	46	13	22	37	30	42	11	599	29	58	628	38
Peak Hour Factor	0.89	0.89	0.89	0.89	0.89	0.89	0.89	0.89	0.89	0.89	0.89	0.89
Percent Heavy Veh, %	2	2	2	2	2	2	2	2	2	2	2	2
Cap, veh/h	286	50	57	216	71	82	26	1138	508	113	1312	585
Arrive On Green	0.13	0.13	0.13	0.13	0.13	0.13	0.01	0.32	0.32	0.06	0.37	0.37
Sat Flow, veh/h	795	383	439	461	547	632	1781	3554	1585	1781	3554	1585
Grp Volume(v), veh/h	81	0	0	109	0	0	11	599	29	58	628	38
Grp Sat Flow(s),veh/h/ln	1618	0	0	1639	0	0	1781	1777	1585	1781	1777	1585
Q Serve(g_s), s	0.0	0.0	0.0	0.5	0.0	0.0	0.2	4.3	0.4	1.0	4.2	0.5
Cycle Q Clear(g_c), s	1.3	0.0	0.0	1.8	0.0	0.0	0.2	4.3	0.4	1.0	4.2	0.5
Prop In Lane	0.57		0.27	0.34		0.39	1.00		1.00	1.00		1.00
Lane Grp Cap(c), veh/h	393	0	0	370	0	0	26	1138	508	113	1312	585
V/C Ratio(X)	0.21	0.00	0.00	0.29	0.00	0.00	0.42	0.53	0.06	0.51	0.48	0.06
Avail Cap(c_a), veh/h	1055	0	0	1080	0	0	289	2418	1078	346	2533	1130
HCM Platoon Ratio	1.00	1.00	1.00	1.00	1.00	1.00	1.00	1.00	1.00	1.00	1.00	1.00
Upstream Filter(l)	1.00	0.00	0.00	1.00	0.00	0.00	1.00	1.00	1.00	1.00	1.00	1.00
Uniform Delay (d), s/veh	12.2	0.0	0.0	12.4	0.0	0.0	15.1	8.6	7.3	14.0	7.5	6.3
Incr Delay (d2), s/veh	0.3	0.0	0.0	0.4	0.0	0.0	10.6	0.4	0.0	3.6	0.3	0.0
Initial Q Delay(d3),s/veh	0.0	0.0	0.0	0.0	0.0	0.0	0.0	0.0	0.0	0.0	0.0	0.0
%ile BackOfQ(50%),veh/ln	0.4	0.0	0.0	0.6	0.0	0.0	0.1	1.1	0.1	0.4	1.0	0.1
Unsig. Movement Delay, s/veh												
LnGrp Delay(d),s/veh	12.5	0.0	0.0	12.9	0.0	0.0	25.7	9.0	7.3	17.6	7.7	6.3
LnGrp LOS	B	A	A	B	A	A	C	A	A	B	A	A
Approach Vol, veh/h		81			109			639			724	
Approach Delay, s/veh		12.5			12.9			9.2			8.4	
Approach LOS		B			B			A			A	
Timer - Assigned Phs	1	2		4	5	6		8				
Phs Duration (G+Y+Rc), s	7.0	14.9		9.0	5.5	16.4		9.0				
Change Period (Y+Rc), s	5.0	5.0		5.0	5.0	5.0		5.0				
Max Green Setting (Gmax), s	6.0	21.0		18.0	5.0	22.0		18.0				
Max Q Clear Time (g_c+I1), s	3.0	6.3		3.3	2.2	6.2		3.8				
Green Ext Time (p_c), s	0.0	3.6		0.3	0.0	4.0		0.4				
Intersection Summary												
HCM 6th Ctrl Delay				9.3								
HCM 6th LOS				A								

Intersection												
Int Delay, s/veh	0.3											
Movement	EBL	EBT	EBR	WBL	WBT	WBR	NBL	NBT	NBR	SBL	SBT	SBR
Lane Configurations		↕			↕		↕	↕		↕	↕	
Traffic Vol, veh/h	6	4	0	7	0	5	1	571	7	6	595	17
Future Vol, veh/h	6	4	0	7	0	5	1	571	7	6	595	17
Conflicting Peds, #/hr	0	0	0	0	0	0	0	0	0	0	0	0
Sign Control	Stop	Stop	Stop	Stop	Stop	Stop	Free	Free	Free	Free	Free	Free
RT Channelized	-	-	None	-	-	None	-	-	None	-	-	None
Storage Length	-	-	-	-	-	-	50	-	-	50	-	-
Veh in Median Storage, #	-	1	-	-	1	-	-	0	-	-	0	-
Grade, %	-	0	-	-	0	-	-	0	-	-	0	-
Peak Hour Factor	92	92	92	92	92	92	92	92	92	92	92	92
Heavy Vehicles, %	2	2	2	2	2	2	2	2	2	2	2	2
Mvmt Flow	7	4	0	8	0	5	1	621	8	7	647	18

Major/Minor	Minor2		Minor1		Major1			Major2				
Conflicting Flow All	983	1301	333	967	1306	315	665	0	0	629	0	0
Stage 1	670	670	-	627	627	-	-	-	-	-	-	-
Stage 2	313	631	-	340	679	-	-	-	-	-	-	-
Critical Hdwy	7.54	6.54	6.94	7.54	6.54	6.94	4.14	-	-	4.14	-	-
Critical Hdwy Stg 1	6.54	5.54	-	6.54	5.54	-	-	-	-	-	-	-
Critical Hdwy Stg 2	6.54	5.54	-	6.54	5.54	-	-	-	-	-	-	-
Follow-up Hdwy	3.52	4.02	3.32	3.52	4.02	3.32	2.22	-	-	2.22	-	-
Pot Cap-1 Maneuver	203	160	663	209	159	681	920	-	-	949	-	-
Stage 1	413	454	-	438	474	-	-	-	-	-	-	-
Stage 2	672	473	-	648	449	-	-	-	-	-	-	-
Platoon blocked, %								-	-	-	-	-
Mov Cap-1 Maneuver	200	159	663	205	158	681	920	-	-	949	-	-
Mov Cap-2 Maneuver	315	282	-	325	282	-	-	-	-	-	-	-
Stage 1	413	451	-	438	474	-	-	-	-	-	-	-
Stage 2	666	473	-	637	446	-	-	-	-	-	-	-

Approach	EB		WB		NB			SB		
HCM Control Delay, s	17.4		13.9		0			0.1		
HCM LOS	C		B							

Minor Lane/Major Mvmt	NBL	NBT	NBR	EBLn1	WBLn1	SBL	SBT	SBR
Capacity (veh/h)	920	-	-	301	416	949	-	-
HCM Lane V/C Ratio	0.001	-	-	0.036	0.031	0.007	-	-
HCM Control Delay (s)	8.9	-	-	17.4	13.9	8.8	-	-
HCM Lane LOS	A	-	-	C	B	A	-	-
HCM 95th %tile Q(veh)	0	-	-	0.1	0.1	0	-	-

Intersection						
Int Delay, s/veh	0.7					
Movement	WBL	WBR	NBT	NBR	SBL	SBT
Lane Configurations	↔		↑↓		↔	↑↑
Traffic Vol, veh/h	20	10	572	30	30	559
Future Vol, veh/h	20	10	572	30	30	559
Conflicting Peds, #/hr	0	0	0	0	0	0
Sign Control	Stop	Stop	Free	Free	Free	Free
RT Channelized	-	None	-	None	-	None
Storage Length	0	-	-	-	140	-
Veh in Median Storage, #	0	-	0	-	-	0
Grade, %	0	-	0	-	-	0
Peak Hour Factor	91	91	91	91	91	91
Heavy Vehicles, %	2	2	2	2	2	2
Mvmt Flow	22	11	629	33	33	614

Major/Minor	Minor1	Major1	Major2			
Conflicting Flow All	1019	331	0	0	662	0
Stage 1	646	-	-	-	-	-
Stage 2	373	-	-	-	-	-
Critical Hdwy	6.84	6.94	-	-	4.14	-
Critical Hdwy Stg 1	5.84	-	-	-	-	-
Critical Hdwy Stg 2	5.84	-	-	-	-	-
Follow-up Hdwy	3.52	3.32	-	-	2.22	-
Pot Cap-1 Maneuver	233	665	-	-	922	-
Stage 1	484	-	-	-	-	-
Stage 2	666	-	-	-	-	-
Platoon blocked, %			-	-		
Mov Cap-1 Maneuver	225	665	-	-	922	-
Mov Cap-2 Maneuver	225	-	-	-	-	-
Stage 1	484	-	-	-	-	-
Stage 2	642	-	-	-	-	-

Approach	WB	NB	SB
HCM Control Delay, s	19.1	0	0.5
HCM LOS	C		

Minor Lane/Major Mvmt	NBT	NBRWBLn1	SBL	SBT
Capacity (veh/h)	-	-	289	922
HCM Lane V/C Ratio	-	-	0.114	0.036
HCM Control Delay (s)	-	-	19.1	9
HCM Lane LOS	-	-	C	A
HCM 95th %tile Q(veh)	-	-	0.4	0.1

Heritage at Dalia Ranch
4: Imperial Ave & Neckel Rd

Opening Year 2023 + P1 Proj
Timing Plan: PM PEAK

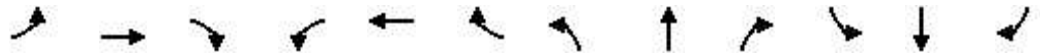

Movement	EBL	EBT	EBR	WBL	WBT	WBR	NBL	NBT	NBR	SBL	SBT	SBR
Lane Configurations		↕			↕		↕	↕		↕	↕	
Traffic Volume (veh/h)	22	26	38	82	20	46	70	555	83	29	496	45
Future Volume (veh/h)	22	26	38	82	20	46	70	555	83	29	496	45
Initial Q (Qb), veh	0	0	0	0	0	0	0	0	0	0	0	0
Ped-Bike Adj(A_pbT)	1.00		1.00	1.00		1.00	1.00		1.00	1.00		1.00
Parking Bus, Adj	1.00	1.00	1.00	1.00	1.00	1.00	1.00	1.00	1.00	1.00	1.00	1.00
Work Zone On Approach		No			No			No			No	
Adj Sat Flow, veh/h/ln	1870	1870	1870	1870	1870	1870	1870	1870	1870	1870	1870	1870
Adj Flow Rate, veh/h	24	28	41	89	22	50	76	603	90	32	539	49
Peak Hour Factor	0.92	0.92	0.92	0.92	0.92	0.92	0.92	0.92	0.92	0.92	0.92	0.92
Percent Heavy Veh, %	2	2	2	2	2	2	2	2	2	2	2	2
Cap, veh/h	35	40	59	123	30	69	124	897	134	66	846	77
Arrive On Green	0.08	0.08	0.08	0.13	0.13	0.13	0.07	0.29	0.29	0.04	0.26	0.26
Sat Flow, veh/h	442	516	755	954	236	536	1781	3102	462	1781	3295	299
Grp Volume(v), veh/h	93	0	0	161	0	0	76	345	348	32	290	298
Grp Sat Flow(s),veh/h/ln	1712	0	0	1726	0	0	1781	1777	1787	1781	1777	1817
Q Serve(g_s), s	2.3	0.0	0.0	3.8	0.0	0.0	1.8	7.3	7.4	0.8	6.2	6.2
Cycle Q Clear(g_c), s	2.3	0.0	0.0	3.8	0.0	0.0	1.8	7.3	7.4	0.8	6.2	6.2
Prop In Lane	0.26		0.44	0.55		0.31	1.00		0.26	1.00		0.16
Lane Grp Cap(c), veh/h	134	0	0	222	0	0	124	514	517	66	456	467
V/C Ratio(X)	0.70	0.00	0.00	0.72	0.00	0.00	0.61	0.67	0.67	0.49	0.64	0.64
Avail Cap(c_a), veh/h	719	0	0	725	0	0	208	788	792	208	788	805
HCM Platoon Ratio	1.00	1.00	1.00	1.00	1.00	1.00	1.00	1.00	1.00	1.00	1.00	1.00
Upstream Filter(l)	1.00	0.00	0.00	1.00	0.00	0.00	1.00	1.00	1.00	1.00	1.00	1.00
Uniform Delay (d), s/veh	19.3	0.0	0.0	17.9	0.0	0.0	19.4	13.4	13.4	20.2	14.1	14.2
Incr Delay (d2), s/veh	6.3	0.0	0.0	4.4	0.0	0.0	4.9	1.5	1.5	5.5	1.5	1.5
Initial Q Delay(d3),s/veh	0.0	0.0	0.0	0.0	0.0	0.0	0.0	0.0	0.0	0.0	0.0	0.0
%ile BackOfQ(50%),veh/ln	1.0	0.0	0.0	1.6	0.0	0.0	0.8	2.6	2.6	0.4	2.2	2.3
Unsig. Movement Delay, s/veh												
LnGrp Delay(d),s/veh	25.6	0.0	0.0	22.4	0.0	0.0	24.2	15.0	15.0	25.7	15.6	15.6
LnGrp LOS	C	A	A	C	A	A	C	B	B	C	B	B
Approach Vol, veh/h		93			161			769			620	
Approach Delay, s/veh		25.6			22.4			15.9			16.1	
Approach LOS		C			C			B			B	
Timer - Assigned Phs	1	2		4	5	6		8				
Phs Duration (G+Y+Rc), s	6.6	17.4		8.3	8.0	16.0		10.5				
Change Period (Y+Rc), s	5.0	5.0		5.0	5.0	5.0		5.0				
Max Green Setting (Gmax), s	5.0	19.0		18.0	5.0	19.0		18.0				
Max Q Clear Time (g_c+I1), s	2.8	9.4		4.3	3.8	8.2		5.8				
Green Ext Time (p_c), s	0.0	3.0		0.3	0.0	2.7		0.6				
Intersection Summary												
HCM 6th Ctrl Delay				17.2								
HCM 6th LOS				B								

Intersection												
Int Delay, s/veh	7.4											
Movement	EBL	EBT	EBR	WBL	WBT	WBR	NBL	NBT	NBR	SBL	SBT	SBR
Lane Configurations		↕			↕			↕			↕	
Traffic Vol, veh/h	2	38	8	28	44	1	5	6	18	0	5	7
Future Vol, veh/h	2	38	8	28	44	1	5	6	18	0	5	7
Conflicting Peds, #/hr	0	0	0	0	0	0	0	0	0	0	0	0
Sign Control	Stop	Stop	Stop	Stop	Stop	Stop	Free	Free	Free	Free	Free	Free
RT Channelized	-	-	None	-	-	None	-	-	None	-	-	None
Storage Length	-	-	-	-	-	-	-	-	-	-	-	-
Veh in Median Storage, #	-	0	-	-	0	-	-	0	-	-	0	-
Grade, %	-	0	-	-	0	-	-	0	-	-	0	-
Peak Hour Factor	79	79	79	79	79	79	79	79	79	79	79	79
Heavy Vehicles, %	2	2	2	2	2	2	2	2	2	2	2	2
Mvmt Flow	3	48	10	35	56	1	6	8	23	0	6	9

Major/Minor	Minor2		Minor1		Major1			Major2				
Conflicting Flow All	71	54	11	72	47	20	15	0	0	31	0	0
Stage 1	11	11	-	32	32	-	-	-	-	-	-	-
Stage 2	60	43	-	40	15	-	-	-	-	-	-	-
Critical Hdwy	7.12	6.52	6.22	7.12	6.52	6.22	4.12	-	-	4.12	-	-
Critical Hdwy Stg 1	6.12	5.52	-	6.12	5.52	-	-	-	-	-	-	-
Critical Hdwy Stg 2	6.12	5.52	-	6.12	5.52	-	-	-	-	-	-	-
Follow-up Hdwy	3.518	4.018	3.318	3.518	4.018	3.318	2.218	-	-	2.218	-	-
Pot Cap-1 Maneuver	920	837	1070	919	845	1058	1603	-	-	1582	-	-
Stage 1	1010	886	-	984	868	-	-	-	-	-	-	-
Stage 2	951	859	-	975	883	-	-	-	-	-	-	-
Platoon blocked, %								-	-	-	-	-
Mov Cap-1 Maneuver	869	834	1070	868	842	1058	1603	-	-	1582	-	-
Mov Cap-2 Maneuver	869	834	-	868	842	-	-	-	-	-	-	-
Stage 1	1006	886	-	980	865	-	-	-	-	-	-	-
Stage 2	885	856	-	913	883	-	-	-	-	-	-	-

Approach	EB		WB		NB		SB	
HCM Control Delay, s	9.5		9.7		1.3		0	
HCM LOS	A		A					

Minor Lane/Major Mvmt	NBL	NBT	NBR	EBLn1	WBLn1	SBL	SBT	SBR
Capacity (veh/h)	1603	-	-	867	854	1582	-	-
HCM Lane V/C Ratio	0.004	-	-	0.07	0.108	-	-	-
HCM Control Delay (s)	7.3	0	-	9.5	9.7	0	-	-
HCM Lane LOS	A	A	-	A	A	A	-	-
HCM 95th %tile Q(veh)	0	-	-	0.2	0.4	0	-	-

Heritage at Dalia Ranch
6: Imperial Ave & Worthington Rd/Barioni Blvd

Opening Year 2023 + P1 Proj
Timing Plan: PM PEAK

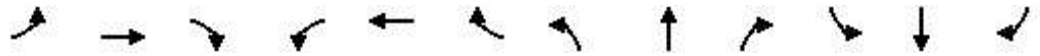

Movement	EBL	EBT	EBR	WBL	WBT	WBR	NBL	NBT	NBR	SBL	SBT	SBR
Lane Configurations		↖	↗		↖	↗	↖	↗	↖	↗	↖	↗
Traffic Volume (veh/h)	48	74	105	54	112	59	112	716	14	32	622	63
Future Volume (veh/h)	48	74	105	54	112	59	112	716	14	32	622	63
Initial Q (Qb), veh	0	0	0	0	0	0	0	0	0	0	0	0
Ped-Bike Adj(A_pbT)	1.00		1.00	1.00		1.00	1.00		1.00	1.00		1.00
Parking Bus, Adj	1.00	1.00	1.00	1.00	1.00	1.00	1.00	1.00	1.00	1.00	1.00	1.00
Work Zone On Approach		No			No			No			No	
Adj Sat Flow, veh/h/ln	1870	1870	1870	1870	1870	1870	1870	1870	1870	1870	1870	1870
Adj Flow Rate, veh/h	53	81	115	59	123	65	123	787	15	35	684	69
Peak Hour Factor	0.91	0.91	0.91	0.91	0.91	0.91	0.91	0.91	0.91	0.91	0.91	0.91
Percent Heavy Veh, %	2	2	2	2	2	2	2	2	2	2	2	2
Cap, veh/h	87	133	190	86	179	228	157	1155	22	68	892	90
Arrive On Green	0.12	0.12	0.12	0.14	0.14	0.14	0.09	0.32	0.32	0.04	0.27	0.27
Sat Flow, veh/h	725	1109	1585	597	1244	1585	1781	3567	68	1781	3260	329
Grp Volume(v), veh/h	134	0	115	182	0	65	123	392	410	35	373	380
Grp Sat Flow(s),veh/h/ln	1834	0	1585	1841	0	1585	1781	1777	1858	1781	1777	1811
Q Serve(g_s), s	3.7	0.0	3.7	5.0	0.0	2.0	3.6	10.2	10.2	1.0	10.3	10.3
Cycle Q Clear(g_c), s	3.7	0.0	3.7	5.0	0.0	2.0	3.6	10.2	10.2	1.0	10.3	10.3
Prop In Lane	0.40		1.00	0.32		1.00	1.00		0.04	1.00		0.18
Lane Grp Cap(c), veh/h	219	0	190	265	0	228	157	575	602	68	486	495
V/C Ratio(X)	0.61	0.00	0.61	0.69	0.00	0.28	0.78	0.68	0.68	0.52	0.77	0.77
Avail Cap(c_a), veh/h	618	0	534	621	0	534	200	632	661	167	599	611
HCM Platoon Ratio	1.00	1.00	1.00	1.00	1.00	1.00	1.00	1.00	1.00	1.00	1.00	1.00
Upstream Filter(l)	1.00	0.00	1.00	1.00	0.00	1.00	1.00	1.00	1.00	1.00	1.00	1.00
Uniform Delay (d), s/veh	22.3	0.0	22.3	21.7	0.0	20.4	23.8	15.7	15.7	25.2	17.8	17.8
Incr Delay (d2), s/veh	2.7	0.0	3.1	3.2	0.0	0.7	14.2	2.6	2.5	6.0	4.7	4.7
Initial Q Delay(d3),s/veh	0.0	0.0	0.0	0.0	0.0	0.0	0.0	0.0	0.0	0.0	0.0	0.0
%ile BackOfQ(50%),veh/ln	1.6	0.0	1.4	2.2	0.0	0.7	2.0	4.0	4.2	0.5	4.4	4.4
Unsig. Movement Delay, s/veh												
LnGrp Delay(d),s/veh	25.1	0.0	25.4	24.9	0.0	21.1	38.0	18.3	18.2	31.2	22.6	22.5
LnGrp LOS	C	A	C	C	A	C	D	B	B	C	C	C
Approach Vol, veh/h		249			247			925			788	
Approach Delay, s/veh		25.2			23.9			20.9			22.9	
Approach LOS		C			C			C			C	
Timer - Assigned Phs	1	2		4	5	6		8				
Phs Duration (G+Y+Rc), s	7.0	22.3		11.4	9.7	19.6		12.7				
Change Period (Y+Rc), s	5.0	5.0		5.0	5.0	5.0		5.0				
Max Green Setting (Gmax), s	5.0	19.0		18.0	6.0	18.0		18.0				
Max Q Clear Time (g_c+I1), s	3.0	12.2		5.7	5.6	12.3		7.0				
Green Ext Time (p_c), s	0.0	2.8		0.8	0.0	2.3		0.9				
Intersection Summary												
HCM 6th Ctrl Delay			22.4									
HCM 6th LOS			C									

Heritage at Dalia Ranch
7: La Brucherie Rd & Worthington Rd

Opening Year 2023 + P1 Proj
Timing Plan: PM PEAK

Intersection												
Intersection Delay, s/veh	10.7											
Intersection LOS	B											

Movement	EBL	EBT	EBR	WBL	WBT	WBR	NBL	NBT	NBR	SBL	SBT	SBR
Lane Configurations		↔	↔		↔	↔		↔			↔	
Traffic Vol, veh/h	34	187	33	27	215	34	1	0	0	37	5	29
Future Vol, veh/h	34	187	33	27	215	34	1	0	0	37	5	29
Peak Hour Factor	0.80	0.80	0.80	0.80	0.80	0.80	0.80	0.80	0.80	0.80	0.80	0.80
Heavy Vehicles, %	2	2	2	2	2	2	2	2	2	2	2	2
Mvmt Flow	43	234	41	34	269	43	1	0	0	46	6	36
Number of Lanes	0	1	1	0	1	1	0	1	0	0	1	0

Approach	EB	WB	NB	SB
Opposing Approach	WB	EB	SB	NB
Opposing Lanes	2	2	1	1
Conflicting Approach Left	SB	NB	EB	WB
Conflicting Lanes Left	1	1	2	2
Conflicting Approach Right	NB	SB	WB	EB
Conflicting Lanes Right	1	1	2	2
HCM Control Delay	10.7	11.1	8.9	9.2
HCM LOS	B	B	A	A

Lane	NBLn1	EBLn1	EBLn2	WBLn1	WBLn2	SBLn1
Vol Left, %	100%	15%	0%	11%	0%	52%
Vol Thru, %	0%	85%	0%	89%	0%	7%
Vol Right, %	0%	0%	100%	0%	100%	41%
Sign Control	Stop	Stop	Stop	Stop	Stop	Stop
Traffic Vol by Lane	1	221	33	242	34	71
LT Vol	1	34	0	27	0	37
Through Vol	0	187	0	215	0	5
RT Vol	0	0	33	0	34	29
Lane Flow Rate	1	276	41	302	42	89
Geometry Grp	2	7	7	7	7	2
Degree of Util (X)	0.002	0.395	0.05	0.429	0.051	0.131
Departure Headway (Hd)	5.82	5.145	4.363	5.102	4.342	5.311
Convergence, Y/N	Yes	Yes	Yes	Yes	Yes	Yes
Cap	611	699	818	705	822	673
Service Time	3.893	2.884	2.103	2.84	2.08	3.364
HCM Lane V/C Ratio	0.002	0.395	0.05	0.428	0.051	0.132
HCM Control Delay	8.9	11.2	7.3	11.6	7.3	9.2
HCM Lane LOS	A	B	A	B	A	A
HCM 95th-tile Q	0	1.9	0.2	2.2	0.2	0.4

Heritage at Dalia Ranch
8: Imperial Ave & Aten Rd

Opening Year 2023 + P1 Proj
Timing Plan: PM PEAK



Movement	EBL	EBT	EBR	WBL	WBT	WBR	NBL	NBT	NBR	SBL	SBT	SBR
Lane Configurations												
Traffic Volume (veh/h)	197	276	68	178	288	130	78	698	149	117	557	214
Future Volume (veh/h)	197	276	68	178	288	130	78	698	149	117	557	214
Initial Q (Qb), veh	0	0	0	0	0	0	0	0	0	0	0	0
Ped-Bike Adj(A_pbT)	1.00		1.00	1.00		1.00	1.00		1.00	1.00		1.00
Parking Bus, Adj	1.00	1.00	1.00	1.00	1.00	1.00	1.00	1.00	1.00	1.00	1.00	1.00
Work Zone On Approach		No			No			No			No	
Adj Sat Flow, veh/h/ln	1870	1870	1870	1870	1870	1870	1870	1870	1870	1870	1870	1870
Adj Flow Rate, veh/h	210	294	72	189	306	138	83	743	159	124	593	228
Peak Hour Factor	0.94	0.94	0.94	0.94	0.94	0.94	0.94	0.94	0.94	0.94	0.94	0.94
Percent Heavy Veh, %	2	2	2	2	2	2	2	2	2	2	2	2
Cap, veh/h	257	552	133	235	437	193	109	940	419	158	1039	463
Arrive On Green	0.14	0.19	0.19	0.13	0.18	0.18	0.06	0.26	0.26	0.09	0.29	0.29
Sat Flow, veh/h	1781	2840	684	1781	2399	1058	1781	3554	1585	1781	3554	1585
Grp Volume(v), veh/h	210	182	184	189	225	219	83	743	159	124	593	228
Grp Sat Flow(s),veh/h/ln	1781	1777	1747	1781	1777	1680	1781	1777	1585	1781	1777	1585
Q Serve(g_s), s	7.1	5.7	5.9	6.4	7.4	7.7	2.9	12.1	5.1	4.3	8.9	7.4
Cycle Q Clear(g_c), s	7.1	5.7	5.9	6.4	7.4	7.7	2.9	12.1	5.1	4.3	8.9	7.4
Prop In Lane	1.00		0.39	1.00		0.63	1.00		1.00	1.00		1.00
Lane Grp Cap(c), veh/h	257	345	340	235	323	306	109	940	419	158	1039	463
V/C Ratio(X)	0.82	0.53	0.54	0.80	0.70	0.72	0.76	0.79	0.38	0.78	0.57	0.49
Avail Cap(c_a), veh/h	314	512	504	314	512	484	171	1081	482	200	1138	508
HCM Platoon Ratio	1.00	1.00	1.00	1.00	1.00	1.00	1.00	1.00	1.00	1.00	1.00	1.00
Upstream Filter(l)	1.00	1.00	1.00	1.00	1.00	1.00	1.00	1.00	1.00	1.00	1.00	1.00
Uniform Delay (d), s/veh	25.9	22.6	22.6	26.3	23.9	24.0	28.9	21.4	18.8	27.9	18.8	18.3
Incr Delay (d2), s/veh	13.0	1.2	1.3	10.6	2.7	3.1	10.5	3.5	0.6	14.5	0.6	0.8
Initial Q Delay(d3),s/veh	0.0	0.0	0.0	0.0	0.0	0.0	0.0	0.0	0.0	0.0	0.0	0.0
%ile BackOfQ(50%),veh/ln	3.8	2.4	2.4	3.3	3.1	3.1	1.5	5.1	1.8	2.4	3.4	2.6
Unsig. Movement Delay, s/veh												
LnGrp Delay(d),s/veh	38.9	23.8	24.0	36.9	26.6	27.2	39.3	24.9	19.3	42.4	19.3	19.1
LnGrp LOS	D	C	C	D	C	C	D	C	B	D	B	B
Approach Vol, veh/h		576			633			985			945	
Approach Delay, s/veh		29.4			29.9			25.2			22.3	
Approach LOS		C			C			C			C	
Timer - Assigned Phs	1	2	3	4	5	6	7	8				
Phs Duration (G+Y+Rc), s	10.5	21.5	13.2	17.1	8.8	23.2	14.0	16.4				
Change Period (Y+Rc), s	5.0	5.0	5.0	5.0	5.0	5.0	5.0	5.0				
Max Green Setting (Gmax), s	19.0	19.0	11.0	18.0	6.0	20.0	11.0	18.0				
Max Q Clear Time (g_c+1/3), s	14.1	14.1	8.4	7.9	4.9	10.9	9.1	9.7				
Green Ext Time (p_c), s	0.0	2.4	0.1	1.5	0.0	3.3	0.1	1.7				
Intersection Summary												
HCM 6th Ctrl Delay											26.0	
HCM 6th LOS											C	

Intersection						
Int Delay, s/veh	2.2					
Movement	EBL	EBT	WBT	WBR	SBL	SBR
Lane Configurations	↙	↑	↗		↙	↗
Traffic Vol, veh/h	8	42	59	76	43	5
Future Vol, veh/h	8	42	59	76	43	5
Conflicting Peds, #/hr	0	0	0	0	0	0
Sign Control	Free	Free	Free	Free	Stop	Stop
RT Channelized	-	None	-	None	-	None
Storage Length	50	-	-	-	0	0
Veh in Median Storage, #	-	0	0	-	0	-
Grade, %	-	0	0	-	0	-
Peak Hour Factor	92	92	92	92	92	92
Heavy Vehicles, %	2	2	2	2	2	2
Mvmt Flow	9	46	64	83	47	5

Major/Minor	Major1	Major2	Minor2		
Conflicting Flow All	147	0	-	0	170
Stage 1	-	-	-	-	106
Stage 2	-	-	-	-	64
Critical Hdwy	4.12	-	-	-	6.42
Critical Hdwy Stg 1	-	-	-	-	5.42
Critical Hdwy Stg 2	-	-	-	-	5.42
Follow-up Hdwy	2.218	-	-	-	3.518
Pot Cap-1 Maneuver	1435	-	-	-	820
Stage 1	-	-	-	-	918
Stage 2	-	-	-	-	959
Platoon blocked, %		-	-	-	
Mov Cap-1 Maneuver	1435	-	-	-	815
Mov Cap-2 Maneuver	-	-	-	-	815
Stage 1	-	-	-	-	912
Stage 2	-	-	-	-	959

Approach	EB	WB	SB
HCM Control Delay, s	1.2	0	9.6
HCM LOS			A

Minor Lane/Major Mvmt	EBL	EBT	WBT	WBR	SBLn1	SBLn2
Capacity (veh/h)	1435	-	-	-	815	948
HCM Lane V/C Ratio	0.006	-	-	-	0.057	0.006
HCM Control Delay (s)	7.5	-	-	-	9.7	8.8
HCM Lane LOS	A	-	-	-	A	A
HCM 95th %tile Q(veh)	0	-	-	-	0.2	0

Heritage at Dalia Ranch
1: SR-86 & Keystone Rd

Opening Year 2024
Timing Plan: AM PEAK

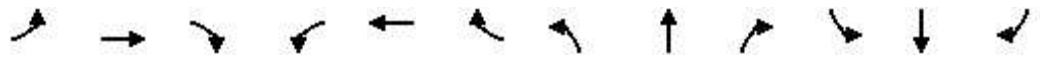

Movement	EBL	EBT	EBR	WBL	WBT	WBR	NBL	NBT	NBR	SBL	SBT	SBR
Lane Configurations		↕			↕		↕	↕↕	↕	↕	↕↕	↕
Traffic Volume (veh/h)	33	33	11	19	24	43	19	445	50	46	519	38
Future Volume (veh/h)	33	33	11	19	24	43	19	445	50	46	519	38
Initial Q (Qb), veh	0	0	0	0	0	0	0	0	0	0	0	0
Ped-Bike Adj(A_pbT)	1.00		1.00	1.00		1.00	1.00		1.00	1.00		1.00
Parking Bus, Adj	1.00	1.00	1.00	1.00	1.00	1.00	1.00	1.00	1.00	1.00	1.00	1.00
Work Zone On Approach		No			No			No			No	
Adj Sat Flow, veh/h/ln	1870	1870	1870	1870	1870	1870	1870	1870	1870	1870	1870	1870
Adj Flow Rate, veh/h	37	37	12	21	27	48	21	494	56	51	577	42
Peak Hour Factor	0.90	0.90	0.90	0.90	0.90	0.90	0.90	0.90	0.90	0.90	0.90	0.90
Percent Heavy Veh, %	2	2	2	2	2	2	2	2	2	2	2	2
Cap, veh/h	260	111	31	190	74	110	48	1009	450	104	1121	500
Arrive On Green	0.13	0.13	0.13	0.13	0.13	0.13	0.03	0.28	0.28	0.06	0.32	0.32
Sat Flow, veh/h	598	831	232	272	550	823	1781	3554	1585	1781	3554	1585
Grp Volume(v), veh/h	86	0	0	96	0	0	21	494	56	51	577	42
Grp Sat Flow(s),veh/h/ln	1660	0	0	1645	0	0	1781	1777	1585	1781	1777	1585
Q Serve(g_s), s	0.0	0.0	0.0	0.2	0.0	0.0	0.3	3.3	0.8	0.8	3.8	0.5
Cycle Q Clear(g_c), s	1.2	0.0	0.0	1.5	0.0	0.0	0.3	3.3	0.8	0.8	3.8	0.5
Prop In Lane	0.43		0.14	0.22		0.50	1.00		1.00	1.00		1.00
Lane Grp Cap(c), veh/h	402	0	0	373	0	0	48	1009	450	104	1121	500
V/C Ratio(X)	0.21	0.00	0.00	0.26	0.00	0.00	0.44	0.49	0.12	0.49	0.51	0.08
Avail Cap(c_a), veh/h	1172	0	0	1163	0	0	311	2235	997	311	2235	997
HCM Platoon Ratio	1.00	1.00	1.00	1.00	1.00	1.00	1.00	1.00	1.00	1.00	1.00	1.00
Upstream Filter(l)	1.00	0.00	0.00	1.00	0.00	0.00	1.00	1.00	1.00	1.00	1.00	1.00
Uniform Delay (d), s/veh	11.3	0.0	0.0	11.4	0.0	0.0	13.7	8.5	7.6	13.1	8.0	6.9
Incr Delay (d2), s/veh	0.3	0.0	0.0	0.4	0.0	0.0	6.2	0.4	0.1	3.6	0.4	0.1
Initial Q Delay(d3),s/veh	0.0	0.0	0.0	0.0	0.0	0.0	0.0	0.0	0.0	0.0	0.0	0.0
%ile BackOfQ(50%),veh/ln	0.4	0.0	0.0	0.4	0.0	0.0	0.2	0.9	0.2	0.3	0.9	0.1
Unsig. Movement Delay, s/veh												
LnGrp Delay(d),s/veh	11.5	0.0	0.0	11.7	0.0	0.0	19.9	8.9	7.7	16.6	8.4	7.0
LnGrp LOS	B	A	A	B	A	A	B	A	A	B	A	A
Approach Vol, veh/h		86			96			571			670	
Approach Delay, s/veh		11.5			11.7			9.2			8.9	
Approach LOS		B			B			A			A	
Timer - Assigned Phs	1	2		4	5	6		8				
Phs Duration (G+Y+Rc), s	6.7	13.1		8.8	5.8	14.0		8.8				
Change Period (Y+Rc), s	5.0	5.0		5.0	5.0	5.0		5.0				
Max Green Setting (Gmax), s	5.0	18.0		18.0	5.0	18.0		18.0				
Max Q Clear Time (g_c+I1), s	2.8	5.3		3.2	2.3	5.8		3.5				
Green Ext Time (p_c), s	0.0	2.8		0.3	0.0	3.2		0.4				
Intersection Summary												
HCM 6th Ctrl Delay				9.4								
HCM 6th LOS				A								

Intersection												
Int Delay, s/veh	0.4											
Movement	EBL	EBT	EBR	WBL	WBT	WBR	NBL	NBT	NBR	SBL	SBT	SBR
Lane Configurations		↕			↕		↕	↕		↕	↕	
Traffic Vol, veh/h	20	3	2	1	2	5	0	513	1	1	524	7
Future Vol, veh/h	20	3	2	1	2	5	0	513	1	1	524	7
Conflicting Peds, #/hr	0	0	0	0	0	0	0	0	0	0	0	0
Sign Control	Stop	Stop	Stop	Stop	Stop	Stop	Free	Free	Free	Free	Free	Free
RT Channelized	-	-	None	-	-	None	-	-	None	-	-	None
Storage Length	-	-	-	-	-	-	50	-	-	50	-	-
Veh in Median Storage, #	-	1	-	-	1	-	-	0	-	-	0	-
Grade, %	-	0	-	-	0	-	-	0	-	-	0	-
Peak Hour Factor	94	94	94	94	94	94	94	94	94	94	94	94
Heavy Vehicles, %	2	2	2	2	2	2	2	2	2	2	2	2
Mvmt Flow	21	3	2	1	2	5	0	546	1	1	557	7

Major/Minor	Minor2		Minor1		Major1			Major2				
Conflicting Flow All	837	1110	282	829	1113	274	564	0	0	547	0	0
Stage 1	563	563	-	547	547	-	-	-	-	-	-	-
Stage 2	274	547	-	282	566	-	-	-	-	-	-	-
Critical Hdwy	7.54	6.54	6.94	7.54	6.54	6.94	4.14	-	-	4.14	-	-
Critical Hdwy Stg 1	6.54	5.54	-	6.54	5.54	-	-	-	-	-	-	-
Critical Hdwy Stg 2	6.54	5.54	-	6.54	5.54	-	-	-	-	-	-	-
Follow-up Hdwy	3.52	4.02	3.32	3.52	4.02	3.32	2.22	-	-	2.22	-	-
Pot Cap-1 Maneuver	259	208	715	263	207	724	1004	-	-	1018	-	-
Stage 1	478	507	-	489	516	-	-	-	-	-	-	-
Stage 2	709	516	-	701	506	-	-	-	-	-	-	-
Platoon blocked, %								-	-	-	-	-
Mov Cap-1 Maneuver	256	208	715	260	207	724	1004	-	-	1018	-	-
Mov Cap-2 Maneuver	369	328	-	374	327	-	-	-	-	-	-	-
Stage 1	478	506	-	489	516	-	-	-	-	-	-	-
Stage 2	701	516	-	694	505	-	-	-	-	-	-	-

Approach	EB		WB		NB		SB	
HCM Control Delay, s	15.2		12.2		0		0	
HCM LOS	C		B					

Minor Lane/Major Mvmt	NBL	NBT	NBR	EBLn1	WBLn1	SBL	SBT	SBR
Capacity (veh/h)	1004	-	-	378	510	1018	-	-
HCM Lane V/C Ratio	-	-	-	0.07	0.017	0.001	-	-
HCM Control Delay (s)	0	-	-	15.2	12.2	8.5	-	-
HCM Lane LOS	A	-	-	C	B	A	-	-
HCM 95th %tile Q(veh)	0	-	-	0.2	0.1	0	-	-

Intersection						
Int Delay, s/veh	1.6					
Movement	WBL	WBR	NBT	NBR	SBL	SBT
Lane Configurations						
Traffic Vol, veh/h	59	23	491	42	20	507
Future Vol, veh/h	59	23	491	42	20	507
Conflicting Peds, #/hr	0	0	0	0	0	0
Sign Control	Stop	Stop	Free	Free	Free	Free
RT Channelized	-	None	-	None	-	None
Storage Length	0	-	-	-	140	-
Veh in Median Storage, #	0	-	0	-	-	0
Grade, %	0	-	0	-	-	0
Peak Hour Factor	91	91	91	91	91	91
Heavy Vehicles, %	2	2	2	2	2	2
Mvmt Flow	65	25	540	46	22	557

Major/Minor	Minor1	Major1	Major2		
Conflicting Flow All	886	293	0	0	586
Stage 1	563	-	-	-	-
Stage 2	323	-	-	-	-
Critical Hdwy	6.84	6.94	-	-	4.14
Critical Hdwy Stg 1	5.84	-	-	-	-
Critical Hdwy Stg 2	5.84	-	-	-	-
Follow-up Hdwy	3.52	3.32	-	-	2.22
Pot Cap-1 Maneuver	284	703	-	-	985
Stage 1	534	-	-	-	-
Stage 2	706	-	-	-	-
Platoon blocked, %			-	-	-
Mov Cap-1 Maneuver	278	703	-	-	985
Mov Cap-2 Maneuver	278	-	-	-	-
Stage 1	534	-	-	-	-
Stage 2	690	-	-	-	-

Approach	WB	NB	SB
HCM Control Delay, s	19.7	0	0.3
HCM LOS	C		

Minor Lane/Major Mvmt	NBT	NBRWBLn1	SBL	SBT
Capacity (veh/h)	-	-	335	985
HCM Lane V/C Ratio	-	-	0.269	0.022
HCM Control Delay (s)	-	-	19.7	8.7
HCM Lane LOS	-	-	C	A
HCM 95th %tile Q(veh)	-	-	1.1	0.1

Heritage at Dalia Ranch
4: Imperial Ave & Neckel Rd

Opening Year 2024
Timing Plan: AM PEAK



Movement	EBL	EBT	EBR	WBL	WBT	WBR	NBL	NBT	NBR	SBL	SBT	SBR
Lane Configurations		↕			↕		↕	↕		↕	↕	
Traffic Volume (veh/h)	34	44	13	144	65	56	8	448	66	15	518	31
Future Volume (veh/h)	34	44	13	144	65	56	8	448	66	15	518	31
Initial Q (Qb), veh	0	0	0	0	0	0	0	0	0	0	0	0
Ped-Bike Adj(A_pbT)	1.00		1.00	1.00		1.00	1.00		1.00	1.00		1.00
Parking Bus, Adj	1.00	1.00	1.00	1.00	1.00	1.00	1.00	1.00	1.00	1.00	1.00	1.00
Work Zone On Approach		No			No			No			No	
Adj Sat Flow, veh/h/ln	1870	1870	1870	1870	1870	1870	1870	1870	1870	1870	1870	1870
Adj Flow Rate, veh/h	37	48	14	158	71	62	9	492	73	16	569	34
Peak Hour Factor	0.91	0.91	0.91	0.91	0.91	0.91	0.91	0.91	0.91	0.91	0.91	0.91
Percent Heavy Veh, %	2	2	2	2	2	2	2	2	2	2	2	2
Cap, veh/h	52	68	20	208	93	82	21	758	112	36	860	51
Arrive On Green	0.08	0.08	0.08	0.22	0.22	0.22	0.01	0.24	0.24	0.02	0.25	0.25
Sat Flow, veh/h	669	869	253	953	428	374	1781	3106	459	1781	3407	203
Grp Volume(v), veh/h	99	0	0	291	0	0	9	281	284	16	296	307
Grp Sat Flow(s),veh/h/ln	1791	0	0	1755	0	0	1781	1777	1788	1781	1777	1834
Q Serve(g_s), s	2.5	0.0	0.0	7.1	0.0	0.0	0.2	6.5	6.5	0.4	6.8	6.8
Cycle Q Clear(g_c), s	2.5	0.0	0.0	7.1	0.0	0.0	0.2	6.5	6.5	0.4	6.8	6.8
Prop In Lane	0.37		0.14	0.54		0.21	1.00		0.26	1.00		0.11
Lane Grp Cap(c), veh/h	140	0	0	383	0	0	21	434	436	36	449	463
V/C Ratio(X)	0.70	0.00	0.00	0.76	0.00	0.00	0.43	0.65	0.65	0.45	0.66	0.66
Avail Cap(c_a), veh/h	708	0	0	694	0	0	196	741	746	196	741	765
HCM Platoon Ratio	1.00	1.00	1.00	1.00	1.00	1.00	1.00	1.00	1.00	1.00	1.00	1.00
Upstream Filter(I)	1.00	0.00	0.00	1.00	0.00	0.00	1.00	1.00	1.00	1.00	1.00	1.00
Uniform Delay (d), s/veh	20.5	0.0	0.0	16.7	0.0	0.0	22.3	15.4	15.5	22.1	15.3	15.3
Incr Delay (d2), s/veh	6.3	0.0	0.0	3.1	0.0	0.0	13.1	1.6	1.7	8.5	1.7	1.6
Initial Q Delay(d3),s/veh	0.0	0.0	0.0	0.0	0.0	0.0	0.0	0.0	0.0	0.0	0.0	0.0
%ile BackOfQ(50%),veh/ln	1.2	0.0	0.0	2.8	0.0	0.0	0.2	2.4	2.5	0.2	2.5	2.6
Unsig. Movement Delay, s/veh												
LnGrp Delay(d),s/veh	26.8	0.0	0.0	19.8	0.0	0.0	35.5	17.1	17.1	30.5	16.9	16.9
LnGrp LOS	C	A	A	B	A	A	D	B	B	C	B	B
Approach Vol, veh/h		99			291			574			619	
Approach Delay, s/veh		26.8			19.8			17.4			17.3	
Approach LOS		C			B			B			B	
Timer - Assigned Phs	1	2		4	5	6		8				
Phs Duration (G+Y+Rc), s	5.9	16.1		8.6	5.5	16.5		14.9				
Change Period (Y+Rc), s	5.0	5.0		5.0	5.0	5.0		5.0				
Max Green Setting (Gmax), s	5.0	19.0		18.0	5.0	19.0		18.0				
Max Q Clear Time (g_c+I1), s	2.4	8.5		4.5	2.2	8.8		9.1				
Green Ext Time (p_c), s	0.0	2.5		0.3	0.0	2.7		1.1				
Intersection Summary												
HCM 6th Ctrl Delay				18.4								
HCM 6th LOS				B								

Intersection												
Int Delay, s/veh	7.7											
Movement	EBL	EBT	EBR	WBL	WBT	WBR	NBL	NBT	NBR	SBL	SBT	SBR
Lane Configurations		↕			↕			↕			↕	
Traffic Vol, veh/h	4	42	23	60	45	0	7	6	43	1	2	1
Future Vol, veh/h	4	42	23	60	45	0	7	6	43	1	2	1
Conflicting Peds, #/hr	0	0	0	0	0	0	0	0	0	0	0	0
Sign Control	Stop	Stop	Stop	Stop	Stop	Stop	Free	Free	Free	Free	Free	Free
RT Channelized	-	-	None	-	-	None	-	-	None	-	-	None
Storage Length	-	-	-	-	-	-	-	-	-	-	-	-
Veh in Median Storage, #	-	0	-	-	0	-	-	0	-	-	0	-
Grade, %	-	0	-	-	0	-	-	0	-	-	0	-
Peak Hour Factor	79	79	79	79	79	79	79	79	79	79	79	79
Heavy Vehicles, %	2	2	2	2	2	2	2	2	2	2	2	2
Mvmt Flow	5	53	29	76	57	0	9	8	54	1	3	1

Major/Minor	Minor2		Minor1		Major1			Major2				
Conflicting Flow All	88	86	4	100	59	35	4	0	0	62	0	0
Stage 1	6	6	-	53	53	-	-	-	-	-	-	-
Stage 2	82	80	-	47	6	-	-	-	-	-	-	-
Critical Hdwy	7.12	6.52	6.22	7.12	6.52	6.22	4.12	-	-	4.12	-	-
Critical Hdwy Stg 1	6.12	5.52	-	6.12	5.52	-	-	-	-	-	-	-
Critical Hdwy Stg 2	6.12	5.52	-	6.12	5.52	-	-	-	-	-	-	-
Follow-up Hdwy	3.518	4.018	3.318	3.518	4.018	3.318	2.218	-	-	2.218	-	-
Pot Cap-1 Maneuver	897	804	1080	881	832	1038	1618	-	-	1541	-	-
Stage 1	1016	891	-	960	851	-	-	-	-	-	-	-
Stage 2	926	828	-	967	891	-	-	-	-	-	-	-
Platoon blocked, %								-	-	-	-	-
Mov Cap-1 Maneuver	845	798	1080	810	826	1038	1618	-	-	1541	-	-
Mov Cap-2 Maneuver	845	798	-	810	826	-	-	-	-	-	-	-
Stage 1	1010	890	-	954	846	-	-	-	-	-	-	-
Stage 2	858	823	-	884	890	-	-	-	-	-	-	-

Approach	EB		WB		NB		SB	
HCM Control Delay, s	9.6		10.3		0.9		1.8	
HCM LOS	A		B					

Minor Lane/Major Mvmt	NBL	NBT	NBR	EBLn1	WBLn1	SBL	SBT	SBR
Capacity (veh/h)	1618	-	-	877	817	1541	-	-
HCM Lane V/C Ratio	0.005	-	-	0.1	0.163	0.001	-	-
HCM Control Delay (s)	7.2	0	-	9.6	10.3	7.3	0	-
HCM Lane LOS	A	A	-	A	B	A	A	-
HCM 95th %tile Q(veh)	0	-	-	0.3	0.6	0	-	-

Heritage at Dalia Ranch
6: Imperial Ave & Worthington Rd/Barioni Blvd

Opening Year 2024
Timing Plan: AM PEAK



Movement	EBL	EBT	EBR	WBL	WBT	WBR	NBL	NBT	NBR	SBL	SBT	SBR
Lane Configurations		↕	↗		↕	↗	↗	↕↗		↗	↕↗	
Traffic Volume (veh/h)	71	138	215	55	133	78	94	471	51	40	639	56
Future Volume (veh/h)	71	138	215	55	133	78	94	471	51	40	639	56
Initial Q (Qb), veh	0	0	0	0	0	0	0	0	0	0	0	0
Ped-Bike Adj(A_pbT)	1.00		1.00	1.00		1.00	1.00		1.00	1.00		1.00
Parking Bus, Adj	1.00	1.00	1.00	1.00	1.00	1.00	1.00	1.00	1.00	1.00	1.00	1.00
Work Zone On Approach		No			No			No			No	
Adj Sat Flow, veh/h/ln	1870	1870	1870	1870	1870	1870	1870	1870	1870	1870	1870	1870
Adj Flow Rate, veh/h	80	155	242	62	149	88	106	529	57	45	718	63
Peak Hour Factor	0.89	0.89	0.89	0.89	0.89	0.89	0.89	0.89	0.89	0.89	0.89	0.89
Percent Heavy Veh, %	2	2	2	2	2	2	2	2	2	2	2	2
Cap, veh/h	123	237	310	84	201	245	136	958	103	76	868	76
Arrive On Green	0.20	0.20	0.20	0.15	0.15	0.15	0.08	0.30	0.30	0.04	0.26	0.26
Sat Flow, veh/h	626	1213	1585	542	1302	1585	1781	3237	348	1781	3305	290
Grp Volume(v), veh/h	235	0	242	211	0	88	106	290	296	45	386	395
Grp Sat Flow(s),veh/h/ln	1839	0	1585	1843	0	1585	1781	1777	1808	1781	1777	1818
Q Serve(g_s), s	7.6	0.0	9.3	7.0	0.0	3.2	3.8	8.8	8.9	1.6	13.2	13.2
Cycle Q Clear(g_c), s	7.6	0.0	9.3	7.0	0.0	3.2	3.8	8.8	8.9	1.6	13.2	13.2
Prop In Lane	0.34		1.00	0.29		1.00	1.00		0.19	1.00		0.16
Lane Grp Cap(c), veh/h	360	0	310	285	0	245	136	526	535	76	467	478
V/C Ratio(X)	0.65	0.00	0.78	0.74	0.00	0.36	0.78	0.55	0.55	0.59	0.83	0.83
Avail Cap(c_a), veh/h	515	0	444	516	0	444	138	526	535	138	525	537
HCM Platoon Ratio	1.00	1.00	1.00	1.00	1.00	1.00	1.00	1.00	1.00	1.00	1.00	1.00
Upstream Filter(I)	1.00	0.00	1.00	1.00	0.00	1.00	1.00	1.00	1.00	1.00	1.00	1.00
Uniform Delay (d), s/veh	23.9	0.0	24.6	26.0	0.0	24.3	29.2	19.1	19.1	30.2	22.3	22.3
Incr Delay (d2), s/veh	2.0	0.0	5.6	3.8	0.0	0.9	24.2	1.2	1.3	7.0	9.6	9.4
Initial Q Delay(d3),s/veh	0.0	0.0	0.0	0.0	0.0	0.0	0.0	0.0	0.0	0.0	0.0	0.0
%ile BackOfQ(50%),veh/ln	3.3	0.0	3.8	3.2	0.0	1.2	2.4	3.5	3.6	0.8	6.3	6.5
Unsig. Movement Delay, s/veh												
LnGrp Delay(d),s/veh	25.9	0.0	30.2	29.7	0.0	25.2	53.4	20.3	20.3	37.2	31.9	31.8
LnGrp LOS	C	A	C	C	A	C	D	C	C	D	C	C
Approach Vol, veh/h		477			299			692			826	
Approach Delay, s/veh		28.0			28.4			25.4			32.1	
Approach LOS		C			C			C			C	
Timer - Assigned Phs	1	2		4	5	6		8				
Phs Duration (G+Y+Rc), s	7.8	24.0		17.6	9.9	21.9		14.9				
Change Period (Y+Rc), s	5.0	5.0		5.0	5.0	5.0		5.0				
Max Green Setting (Gmax), s	5.0	19.0		18.0	5.0	19.0		18.0				
Max Q Clear Time (g_c+I1), s	3.6	10.9		11.3	5.8	15.2		9.0				
Green Ext Time (p_c), s	0.0	2.2		1.3	0.0	1.7		1.0				

Intersection Summary

HCM 6th Ctrl Delay	28.8
HCM 6th LOS	C

Intersection

Intersection Delay, s/veh 19.9

Intersection LOS C

Movement	EBL	EBT	EBR	WBL	WBT	WBR	NBL	NBT	NBR	SBL	SBT	SBR
Lane Configurations		↔	↔		↔	↔		↔			↔	
Traffic Vol, veh/h	62	395	121	11	305	78	0	0	1	107	31	65
Future Vol, veh/h	62	395	121	11	305	78	0	0	1	107	31	65
Peak Hour Factor	0.92	0.92	0.92	0.92	0.92	0.92	0.92	0.92	0.92	0.92	0.92	0.92
Heavy Vehicles, %	2	2	2	2	2	2	2	2	2	2	2	2
Mvmt Flow	67	429	132	12	332	85	0	0	1	116	34	71
Number of Lanes	0	1	1	0	1	1	0	1	0	0	1	0

Approach	EB	WB	NB	SB
Opposing Approach	WB	EB	SB	NB
Opposing Lanes	2	2	1	1
Conflicting Approach Left	SB	NB	EB	WB
Conflicting Lanes Left	1	1	2	2
Conflicting Approach Right	NB	SB	WB	EB
Conflicting Lanes Right	1	1	2	2
HCM Control Delay	25.3	15.4	9.6	13.3
HCM LOS	D	C	A	B

Lane	NBLn1	EBLn1	EBLn2	WBLn1	WBLn2	SBLn1
Vol Left, %	0%	14%	0%	3%	0%	53%
Vol Thru, %	0%	86%	0%	97%	0%	15%
Vol Right, %	100%	0%	100%	0%	100%	32%
Sign Control	Stop	Stop	Stop	Stop	Stop	Stop
Traffic Vol by Lane	1	457	121	316	78	203
LT Vol	0	62	0	11	0	107
Through Vol	0	395	0	305	0	31
RT Vol	1	0	121	0	78	65
Lane Flow Rate	1	497	132	343	85	221
Geometry Grp	2	7	7	7	7	2
Degree of Util (X)	0.002	0.815	0.187	0.581	0.126	0.386
Departure Headway (Hd)	6.519	5.91	5.131	6.094	5.365	6.304
Convergence, Y/N	Yes	Yes	Yes	Yes	Yes	Yes
Cap	545	611	698	591	666	569
Service Time	4.607	3.651	2.872	3.84	3.111	4.356
HCM Lane V/C Ratio	0.002	0.813	0.189	0.58	0.128	0.388
HCM Control Delay	9.6	29.6	9.1	17	8.9	13.3
HCM Lane LOS	A	D	A	C	A	B
HCM 95th-tile Q	0	8.3	0.7	3.7	0.4	1.8

Heritage at Dalia Ranch
8: Imperial Ave & Aten Rd

Opening Year 2024
Timing Plan: AM PEAK



Movement	EBL	EBT	EBR	WBL	WBT	WBR	NBL	NBT	NBR	SBL	SBT	SBR
Lane Configurations												
Traffic Volume (veh/h)	189	342	64	132	303	143	62	348	68	144	680	381
Future Volume (veh/h)	189	342	64	132	303	143	62	348	68	144	680	381
Initial Q (Qb), veh	0	0	0	0	0	0	0	0	0	0	0	0
Ped-Bike Adj(A_pbT)	1.00		1.00	1.00		1.00	1.00		1.00	1.00		1.00
Parking Bus, Adj	1.00	1.00	1.00	1.00	1.00	1.00	1.00	1.00	1.00	1.00	1.00	1.00
Work Zone On Approach		No		No		No		No		No		No
Adj Sat Flow, veh/h/ln	1870	1870	1870	1870	1870	1870	1870	1870	1870	1870	1870	1870
Adj Flow Rate, veh/h	220	398	74	153	352	166	72	405	79	167	791	443
Peak Hour Factor	0.86	0.86	0.86	0.86	0.86	0.86	0.86	0.86	0.86	0.86	0.86	0.86
Percent Heavy Veh, %	2	2	2	2	2	2	2	2	2	2	2	2
Cap, veh/h	259	704	130	192	464	215	97	892	398	206	1110	495
Arrive On Green	0.15	0.23	0.23	0.11	0.20	0.20	0.05	0.25	0.25	0.12	0.31	0.31
Sat Flow, veh/h	1781	2995	552	1781	2358	1093	1781	3554	1585	1781	3554	1585
Grp Volume(v), veh/h	220	235	237	153	264	254	72	405	79	167	791	443
Grp Sat Flow(s),veh/h/ln	1781	1777	1771	1781	1777	1674	1781	1777	1585	1781	1777	1585
Q Serve(g_s), s	8.3	8.0	8.1	5.8	9.6	9.9	2.7	6.6	2.7	6.3	13.5	18.3
Cycle Q Clear(g_c), s	8.3	8.0	8.1	5.8	9.6	9.9	2.7	6.6	2.7	6.3	13.5	18.3
Prop In Lane	1.00		0.31	1.00		0.65	1.00		1.00	1.00		1.00
Lane Grp Cap(c), veh/h	259	417	416	192	350	330	97	892	398	206	1110	495
V/C Ratio(X)	0.85	0.56	0.57	0.80	0.75	0.77	0.74	0.45	0.20	0.81	0.71	0.90
Avail Cap(c_a), veh/h	259	491	490	233	465	438	130	983	438	207	1138	507
HCM Platoon Ratio	1.00	1.00	1.00	1.00	1.00	1.00	1.00	1.00	1.00	1.00	1.00	1.00
Upstream Filter(l)	1.00	1.00	1.00	1.00	1.00	1.00	1.00	1.00	1.00	1.00	1.00	1.00
Uniform Delay (d), s/veh	28.6	23.2	23.2	29.9	26.0	26.1	32.0	21.8	20.3	29.7	20.9	22.6
Incr Delay (d2), s/veh	22.4	1.2	1.2	14.8	4.8	6.0	14.5	0.4	0.2	20.9	2.1	18.0
Initial Q Delay(d3),s/veh	0.0	0.0	0.0	0.0	0.0	0.0	0.0	0.0	0.0	0.0	0.0	0.0
%ile BackOfQ(50%),veh/ln	5.0	3.3	3.4	3.2	4.3	4.3	1.5	2.6	1.0	3.8	5.5	8.8
Unsig. Movement Delay, s/veh												
LnGrp Delay(d),s/veh	51.0	24.4	24.5	44.7	30.9	32.1	46.5	22.1	20.5	50.6	23.0	40.6
LnGrp LOS	D	C	C	D	C	C	D	C	C	D	C	D
Approach Vol, veh/h		692			671			556			1401	
Approach Delay, s/veh		32.9			34.5			25.1			31.8	
Approach LOS		C			C			C			C	
Timer - Assigned Phs	1	2	3	4	5	6	7	8				
Phs Duration (G+Y+Rc), s	22.9	22.2	12.4	21.1	8.7	26.5	15.0	18.5				
Change Period (Y+Rc), s	5.0	5.0	5.0	5.0	5.0	5.0	5.0	5.0				
Max Green Setting (Gmax), s	19.0	19.0	9.0	19.0	5.0	22.0	10.0	18.0				
Max Q Clear Time (g_c+1/3), s	8.6	8.6	7.8	10.1	4.7	20.3	10.3	11.9				
Green Ext Time (p_c), s	0.0	2.1	0.0	1.9	0.0	1.1	0.0	1.6				
Intersection Summary												
HCM 6th Ctrl Delay				31.4								
HCM 6th LOS				C								

Intersection												
Int Delay, s/veh	0.3											
Movement	EBL	EBT	EBR	WBL	WBT	WBR	NBL	NBT	NBR	SBL	SBT	SBR
Lane Configurations		↕			↕		↕	↕		↕	↕	
Traffic Vol, veh/h	6	4	0	7	0	5	1	569	7	6	586	18
Future Vol, veh/h	6	4	0	7	0	5	1	569	7	6	586	18
Conflicting Peds, #/hr	0	0	0	0	0	0	0	0	0	0	0	0
Sign Control	Stop	Stop	Stop	Stop	Stop	Stop	Free	Free	Free	Free	Free	Free
RT Channelized	-	-	None	-	-	None	-	-	None	-	-	None
Storage Length	-	-	-	-	-	-	50	-	-	50	-	-
Veh in Median Storage, #	-	1	-	-	1	-	-	0	-	-	0	-
Grade, %	-	0	-	-	0	-	-	0	-	-	0	-
Peak Hour Factor	92	92	92	92	92	92	92	92	92	92	92	92
Heavy Vehicles, %	2	2	2	2	2	2	2	2	2	2	2	2
Mvmt Flow	7	4	0	8	0	5	1	618	8	7	637	20

Major/Minor	Minor2		Minor1		Major1			Major2				
Conflicting Flow All	972	1289	329	959	1295	313	657	0	0	626	0	0
Stage 1	661	661	-	624	624	-	-	-	-	-	-	-
Stage 2	311	628	-	335	671	-	-	-	-	-	-	-
Critical Hdwy	7.54	6.54	6.94	7.54	6.54	6.94	4.14	-	-	4.14	-	-
Critical Hdwy Stg 1	6.54	5.54	-	6.54	5.54	-	-	-	-	-	-	-
Critical Hdwy Stg 2	6.54	5.54	-	6.54	5.54	-	-	-	-	-	-	-
Follow-up Hdwy	3.52	4.02	3.32	3.52	4.02	3.32	2.22	-	-	2.22	-	-
Pot Cap-1 Maneuver	207	162	667	211	161	683	926	-	-	952	-	-
Stage 1	418	458	-	440	476	-	-	-	-	-	-	-
Stage 2	674	474	-	653	453	-	-	-	-	-	-	-
Platoon blocked, %								-	-	-	-	-
Mov Cap-1 Maneuver	204	161	667	207	160	683	926	-	-	952	-	-
Mov Cap-2 Maneuver	319	284	-	327	284	-	-	-	-	-	-	-
Stage 1	418	455	-	440	476	-	-	-	-	-	-	-
Stage 2	668	474	-	642	450	-	-	-	-	-	-	-

Approach	EB		WB		NB		SB	
HCM Control Delay, s	17.3		13.9		0		0.1	
HCM LOS	C		B					

Minor Lane/Major Mvmt	NBL	NBT	NBR	EBLn1	WBLn1	SBL	SBT	SBR
Capacity (veh/h)	926	-	-	304	418	952	-	-
HCM Lane V/C Ratio	0.001	-	-	0.036	0.031	0.007	-	-
HCM Control Delay (s)	8.9	-	-	17.3	13.9	8.8	-	-
HCM Lane LOS	A	-	-	C	B	A	-	-
HCM 95th %tile Q(veh)	0	-	-	0.1	0.1	0	-	-

Intersection						
Int Delay, s/veh	0.7					
Movement	WBL	WBR	NBT	NBR	SBL	SBT
Lane Configurations	↔		↑↓		↔	↑↑
Traffic Vol, veh/h	20	10	570	30	30	549
Future Vol, veh/h	20	10	570	30	30	549
Conflicting Peds, #/hr	0	0	0	0	0	0
Sign Control	Stop	Stop	Free	Free	Free	Free
RT Channelized	-	None	-	None	-	None
Storage Length	0	-	-	-	140	-
Veh in Median Storage, #	0	-	0	-	-	0
Grade, %	0	-	0	-	-	0
Peak Hour Factor	91	91	91	91	91	91
Heavy Vehicles, %	2	2	2	2	2	2
Mvmt Flow	22	11	626	33	33	603

Major/Minor	Minor1	Major1	Major2		
Conflicting Flow All	1011	330	0	0	659
Stage 1	643	-	-	-	-
Stage 2	368	-	-	-	-
Critical Hdwy	6.84	6.94	-	-	4.14
Critical Hdwy Stg 1	5.84	-	-	-	-
Critical Hdwy Stg 2	5.84	-	-	-	-
Follow-up Hdwy	3.52	3.32	-	-	2.22
Pot Cap-1 Maneuver	236	666	-	-	925
Stage 1	485	-	-	-	-
Stage 2	670	-	-	-	-
Platoon blocked, %			-	-	-
Mov Cap-1 Maneuver	228	666	-	-	925
Mov Cap-2 Maneuver	228	-	-	-	-
Stage 1	485	-	-	-	-
Stage 2	646	-	-	-	-

Approach	WB	NB	SB
HCM Control Delay, s	18.9	0	0.5
HCM LOS	C		

Minor Lane/Major Mvmt	NBT	NBRWBLn1	SBL	SBT
Capacity (veh/h)	-	-	292	925
HCM Lane V/C Ratio	-	-	0.113	0.036
HCM Control Delay (s)	-	-	18.9	9
HCM Lane LOS	-	-	C	A
HCM 95th %tile Q(veh)	-	-	0.4	0.1

Intersection												
Int Delay, s/veh	7.7											
Movement	EBL	EBT	EBR	WBL	WBT	WBR	NBL	NBT	NBR	SBL	SBT	SBR
Lane Configurations		↕			↕			↕			↕	
Traffic Vol, veh/h	2	39	8	23	45	1	5	6	10	0	5	7
Future Vol, veh/h	2	39	8	23	45	1	5	6	10	0	5	7
Conflicting Peds, #/hr	0	0	0	0	0	0	0	0	0	0	0	0
Sign Control	Stop	Stop	Stop	Stop	Stop	Stop	Free	Free	Free	Free	Free	Free
RT Channelized	-	-	None	-	-	None	-	-	None	-	-	None
Storage Length	-	-	-	-	-	-	-	-	-	-	-	-
Veh in Median Storage, #	-	0	-	-	0	-	-	0	-	-	0	-
Grade, %	-	0	-	-	0	-	-	0	-	-	0	-
Peak Hour Factor	79	79	79	79	79	79	79	79	79	79	79	79
Heavy Vehicles, %	2	2	2	2	2	2	2	2	2	2	2	2
Mvmt Flow	3	49	10	29	57	1	6	8	13	0	6	9

Major/Minor	Minor2		Minor1		Major1			Major2				
Conflicting Flow All	67	44	11	67	42	15	15	0	0	21	0	0
Stage 1	11	11	-	27	27	-	-	-	-	-	-	-
Stage 2	56	33	-	40	15	-	-	-	-	-	-	-
Critical Hdwy	7.12	6.52	6.22	7.12	6.52	6.22	4.12	-	-	4.12	-	-
Critical Hdwy Stg 1	6.12	5.52	-	6.12	5.52	-	-	-	-	-	-	-
Critical Hdwy Stg 2	6.12	5.52	-	6.12	5.52	-	-	-	-	-	-	-
Follow-up Hdwy	3.518	4.018	3.318	3.518	4.018	3.318	2.218	-	-	2.218	-	-
Pot Cap-1 Maneuver	926	848	1070	926	850	1065	1603	-	-	1595	-	-
Stage 1	1010	886	-	990	873	-	-	-	-	-	-	-
Stage 2	956	868	-	975	883	-	-	-	-	-	-	-
Platoon blocked, %								-	-	-	-	-
Mov Cap-1 Maneuver	875	845	1070	873	847	1065	1603	-	-	1595	-	-
Mov Cap-2 Maneuver	875	845	-	873	847	-	-	-	-	-	-	-
Stage 1	1006	886	-	986	870	-	-	-	-	-	-	-
Stage 2	889	865	-	912	883	-	-	-	-	-	-	-

Approach	EB		WB		NB		SB	
HCM Control Delay, s	9.4		9.7		1.7		0	
HCM LOS	A		A					

Minor Lane/Major Mvmt	NBL	NBT	NBR	EBLn1	WBLn1	SBL	SBT	SBR
Capacity (veh/h)	1603	-	-	876	858	1595	-	-
HCM Lane V/C Ratio	0.004	-	-	0.071	0.102	-	-	-
HCM Control Delay (s)	7.3	0	-	9.4	9.7	0	-	-
HCM Lane LOS	A	A	-	A	A	A	-	-
HCM 95th %tile Q(veh)	0	-	-	0.2	0.3	0	-	-

Intersection

Intersection Delay, s/veh 10.6

Intersection LOS B

Movement	EBL	EBT	EBR	WBL	WBT	WBR	NBL	NBT	NBR	SBL	SBT	SBR
Lane Configurations		↔	↔		↔	↔		↔			↔	
Traffic Vol, veh/h	26	190	33	27	218	34	1	0	0	38	5	24
Future Vol, veh/h	26	190	33	27	218	34	1	0	0	38	5	24
Peak Hour Factor	0.80	0.80	0.80	0.80	0.80	0.80	0.80	0.80	0.80	0.80	0.80	0.80
Heavy Vehicles, %	2	2	2	2	2	2	2	2	2	2	2	2
Mvmt Flow	33	238	41	34	273	43	1	0	0	48	6	30
Number of Lanes	0	1	1	0	1	1	0	1	0	0	1	0

Approach	EB	WB	NB	SB
Opposing Approach	WB	EB	SB	NB
Opposing Lanes	2	2	1	1
Conflicting Approach Left	SB	NB	EB	WB
Conflicting Lanes Left	1	1	2	2
Conflicting Approach Right	NB	SB	WB	EB
Conflicting Lanes Right	1	1	2	2
HCM Control Delay	10.5	11.1	8.9	9.2
HCM LOS	B	B	A	A

Lane	NBLn1	EBLn1	EBLn2	WBLn1	WBLn2	SBLn1
Vol Left, %	100%	12%	0%	11%	0%	57%
Vol Thru, %	0%	88%	0%	89%	0%	7%
Vol Right, %	0%	0%	100%	0%	100%	36%
Sign Control	Stop	Stop	Stop	Stop	Stop	Stop
Traffic Vol by Lane	1	216	33	245	34	67
LT Vol	1	26	0	27	0	38
Through Vol	0	190	0	218	0	5
RT Vol	0	0	33	0	34	24
Lane Flow Rate	1	270	41	306	42	84
Geometry Grp	2	7	7	7	7	2
Degree of Util (X)	0.002	0.384	0.05	0.432	0.051	0.124
Departure Headway (Hd)	5.802	5.117	4.352	5.081	4.322	5.342
Convergence, Y/N	Yes	Yes	Yes	Yes	Yes	Yes
Cap	613	702	821	707	827	669
Service Time	3.87	2.853	2.089	2.816	2.057	3.391
HCM Lane V/C Ratio	0.002	0.385	0.05	0.433	0.051	0.126
HCM Control Delay	8.9	11	7.3	11.6	7.3	9.2
HCM Lane LOS	A	B	A	B	A	A
HCM 95th-tile Q	0	1.8	0.2	2.2	0.2	0.4

Heritage at Dalia Ranch
1: SR-86 & Keystone Rd

Opening Year 2024 + P1-2 Proj
Timing Plan: AM PEAK

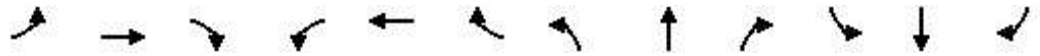

Movement	EBL	EBT	EBR	WBL	WBT	WBR	NBL	NBT	NBR	SBL	SBT	SBR
Lane Configurations		↕			↕		↕	↕↕	↕	↕	↕↕	↕
Traffic Volume (veh/h)	33	33	11	19	24	43	19	475	50	46	529	38
Future Volume (veh/h)	33	33	11	19	24	43	19	475	50	46	529	38
Initial Q (Qb), veh	0	0	0	0	0	0	0	0	0	0	0	0
Ped-Bike Adj(A_pbT)	1.00		1.00	1.00		1.00	1.00		1.00	1.00		1.00
Parking Bus, Adj	1.00	1.00	1.00	1.00	1.00	1.00	1.00	1.00	1.00	1.00	1.00	1.00
Work Zone On Approach		No			No			No			No	
Adj Sat Flow, veh/h/ln	1870	1870	1870	1870	1870	1870	1870	1870	1870	1870	1870	1870
Adj Flow Rate, veh/h	37	37	12	21	27	48	21	528	56	51	588	42
Peak Hour Factor	0.90	0.90	0.90	0.90	0.90	0.90	0.90	0.90	0.90	0.90	0.90	0.90
Percent Heavy Veh, %	2	2	2	2	2	2	2	2	2	2	2	2
Cap, veh/h	256	110	31	187	73	109	48	1046	467	103	1157	516
Arrive On Green	0.13	0.13	0.13	0.13	0.13	0.13	0.03	0.29	0.29	0.06	0.33	0.33
Sat Flow, veh/h	597	832	232	272	551	823	1781	3554	1585	1781	3554	1585
Grp Volume(v), veh/h	86	0	0	96	0	0	21	528	56	51	588	42
Grp Sat Flow(s),veh/h/ln	1661	0	0	1646	0	0	1781	1777	1585	1781	1777	1585
Q Serve(g_s), s	0.0	0.0	0.0	0.2	0.0	0.0	0.3	3.6	0.8	0.8	3.9	0.5
Cycle Q Clear(g_c), s	1.2	0.0	0.0	1.5	0.0	0.0	0.3	3.6	0.8	0.8	3.9	0.5
Prop In Lane	0.43		0.14	0.22		0.50	1.00		1.00	1.00		1.00
Lane Grp Cap(c), veh/h	397	0	0	368	0	0	48	1046	467	103	1157	516
V/C Ratio(X)	0.22	0.00	0.00	0.26	0.00	0.00	0.44	0.50	0.12	0.49	0.51	0.08
Avail Cap(c_a), veh/h	1152	0	0	1143	0	0	306	2197	980	306	2197	980
HCM Platoon Ratio	1.00	1.00	1.00	1.00	1.00	1.00	1.00	1.00	1.00	1.00	1.00	1.00
Upstream Filter(l)	1.00	0.00	0.00	1.00	0.00	0.00	1.00	1.00	1.00	1.00	1.00	1.00
Uniform Delay (d), s/veh	11.5	0.0	0.0	11.6	0.0	0.0	14.0	8.5	7.5	13.3	7.9	6.8
Incr Delay (d2), s/veh	0.3	0.0	0.0	0.4	0.0	0.0	6.2	0.4	0.1	3.6	0.3	0.1
Initial Q Delay(d3),s/veh	0.0	0.0	0.0	0.0	0.0	0.0	0.0	0.0	0.0	0.0	0.0	0.0
%ile BackOfQ(50%),veh/ln	0.4	0.0	0.0	0.5	0.0	0.0	0.2	0.9	0.2	0.4	1.0	0.1
Unsig. Movement Delay, s/veh												
LnGrp Delay(d),s/veh	11.8	0.0	0.0	12.0	0.0	0.0	20.2	8.9	7.6	16.9	8.3	6.9
LnGrp LOS	B	A	A	B	A	A	C	A	A	B	A	A
Approach Vol, veh/h		86			96			605			681	
Approach Delay, s/veh		11.8			12.0			9.2			8.8	
Approach LOS		B			B			A			A	
Timer - Assigned Phs	1	2		4	5	6		8				
Phs Duration (G+Y+Rc), s	6.7	13.6		8.9	5.8	14.5		8.9				
Change Period (Y+Rc), s	5.0	5.0		5.0	5.0	5.0		5.0				
Max Green Setting (Gmax), s	5.0	18.0		18.0	5.0	18.0		18.0				
Max Q Clear Time (g_c+I1), s	2.8	5.6		3.2	2.3	5.9		3.5				
Green Ext Time (p_c), s	0.0	3.0		0.3	0.0	3.3		0.4				
Intersection Summary												
HCM 6th Ctrl Delay				9.3								
HCM 6th LOS				A								

Intersection												
Int Delay, s/veh	0.4											
Movement	EBL	EBT	EBR	WBL	WBT	WBR	NBL	NBT	NBR	SBL	SBT	SBR
Lane Configurations		↕			↕		↕	↕		↕	↕	
Traffic Vol, veh/h	20	3	2	1	2	5	0	543	1	1	534	7
Future Vol, veh/h	20	3	2	1	2	5	0	543	1	1	534	7
Conflicting Peds, #/hr	0	0	0	0	0	0	0	0	0	0	0	0
Sign Control	Stop	Stop	Stop	Stop	Stop	Stop	Free	Free	Free	Free	Free	Free
RT Channelized	-	-	None	-	-	None	-	-	None	-	-	None
Storage Length	-	-	-	-	-	-	50	-	-	50	-	-
Veh in Median Storage, #	-	1	-	-	1	-	-	0	-	-	0	-
Grade, %	-	0	-	-	0	-	-	0	-	-	0	-
Peak Hour Factor	94	94	94	94	94	94	94	94	94	94	94	94
Heavy Vehicles, %	2	2	2	2	2	2	2	2	2	2	2	2
Mvmt Flow	21	3	2	1	2	5	0	578	1	1	568	7

Major/Minor	Minor2		Minor1		Major1			Major2				
Conflicting Flow All	864	1153	288	867	1156	290	575	0	0	579	0	0
Stage 1	574	574	-	579	579	-	-	-	-	-	-	-
Stage 2	290	579	-	288	577	-	-	-	-	-	-	-
Critical Hdwy	7.54	6.54	6.94	7.54	6.54	6.94	4.14	-	-	4.14	-	-
Critical Hdwy Stg 1	6.54	5.54	-	6.54	5.54	-	-	-	-	-	-	-
Critical Hdwy Stg 2	6.54	5.54	-	6.54	5.54	-	-	-	-	-	-	-
Follow-up Hdwy	3.52	4.02	3.32	3.52	4.02	3.32	2.22	-	-	2.22	-	-
Pot Cap-1 Maneuver	248	196	709	247	195	707	994	-	-	991	-	-
Stage 1	471	501	-	468	499	-	-	-	-	-	-	-
Stage 2	694	499	-	695	500	-	-	-	-	-	-	-
Platoon blocked, %								-	-	-	-	-
Mov Cap-1 Maneuver	245	196	709	244	195	707	994	-	-	991	-	-
Mov Cap-2 Maneuver	360	317	-	359	317	-	-	-	-	-	-	-
Stage 1	471	500	-	468	499	-	-	-	-	-	-	-
Stage 2	686	499	-	688	500	-	-	-	-	-	-	-

Approach	EB	WB	NB	SB
HCM Control Delay, s	15.5	12.4	0	0
HCM LOS	C	B		

Minor Lane/Major Mvmt	NBL	NBT	NBR	EBLn1	WBLn1	SBL	SBT	SBR
Capacity (veh/h)	994	-	-	369	495	991	-	-
HCM Lane V/C Ratio	-	-	-	0.072	0.017	0.001	-	-
HCM Control Delay (s)	0	-	-	15.5	12.4	8.6	-	-
HCM Lane LOS	A	-	-	C	B	A	-	-
HCM 95th %tile Q(veh)	0	-	-	0.2	0.1	0	-	-

Intersection						
Int Delay, s/veh	1.6					
Movement	WBL	WBR	NBT	NBR	SBL	SBT
Lane Configurations	↔		↑↓		↔	↑↑
Traffic Vol, veh/h	59	23	521	42	20	517
Future Vol, veh/h	59	23	521	42	20	517
Conflicting Peds, #/hr	0	0	0	0	0	0
Sign Control	Stop	Stop	Free	Free	Free	Free
RT Channelized	-	None	-	None	-	None
Storage Length	0	-	-	-	140	-
Veh in Median Storage, #	0	-	0	-	-	0
Grade, %	0	-	0	-	-	0
Peak Hour Factor	91	91	91	91	91	91
Heavy Vehicles, %	2	2	2	2	2	2
Mvmt Flow	65	25	573	46	22	568

Major/Minor	Minor1	Major1	Major2			
Conflicting Flow All	924	310	0	0	619	0
Stage 1	596	-	-	-	-	-
Stage 2	328	-	-	-	-	-
Critical Hdwy	6.84	6.94	-	-	4.14	-
Critical Hdwy Stg 1	5.84	-	-	-	-	-
Critical Hdwy Stg 2	5.84	-	-	-	-	-
Follow-up Hdwy	3.52	3.32	-	-	2.22	-
Pot Cap-1 Maneuver	268	686	-	-	957	-
Stage 1	513	-	-	-	-	-
Stage 2	702	-	-	-	-	-
Platoon blocked, %			-	-	-	-
Mov Cap-1 Maneuver	262	686	-	-	957	-
Mov Cap-2 Maneuver	262	-	-	-	-	-
Stage 1	513	-	-	-	-	-
Stage 2	686	-	-	-	-	-

Approach	WB	NB	SB
HCM Control Delay, s	20.8	0	0.3
HCM LOS	C		

Minor Lane/Major Mvmt	NBT	NBRWBLn1	SBL	SBT
Capacity (veh/h)	-	-	317	957
HCM Lane V/C Ratio	-	-	0.284	0.023
HCM Control Delay (s)	-	-	20.8	8.8
HCM Lane LOS	-	-	C	A
HCM 95th %tile Q(veh)	-	-	1.1	0.1

Heritage at Dalia Ranch
4: Imperial Ave & Neckel Rd

Opening Year 2024 + P1-2 Proj
Timing Plan: AM PEAK

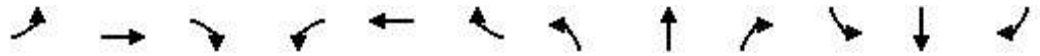

Movement	EBL	EBT	EBR	WBL	WBT	WBR	NBL	NBT	NBR	SBL	SBT	SBR
Lane Configurations		↕			↕		↕	↕		↕	↕	
Traffic Volume (veh/h)	64	44	117	144	65	56	44	448	66	15	518	41
Future Volume (veh/h)	64	44	117	144	65	56	44	448	66	15	518	41
Initial Q (Qb), veh	0	0	0	0	0	0	0	0	0	0	0	0
Ped-Bike Adj(A_pbT)	1.00		1.00	1.00		1.00	1.00		1.00	1.00		1.00
Parking Bus, Adj	1.00	1.00	1.00	1.00	1.00	1.00	1.00	1.00	1.00	1.00	1.00	1.00
Work Zone On Approach		No			No			No			No	
Adj Sat Flow, veh/h/ln	1870	1870	1870	1870	1870	1870	1870	1870	1870	1870	1870	1870
Adj Flow Rate, veh/h	70	48	129	158	71	62	48	492	73	16	569	45
Peak Hour Factor	0.91	0.91	0.91	0.91	0.91	0.91	0.91	0.91	0.91	0.91	0.91	0.91
Percent Heavy Veh, %	2	2	2	2	2	2	2	2	2	2	2	2
Cap, veh/h	88	60	162	195	88	77	82	796	118	35	767	61
Arrive On Green	0.18	0.18	0.18	0.20	0.20	0.20	0.05	0.26	0.26	0.02	0.23	0.23
Sat Flow, veh/h	478	328	881	953	428	374	1781	3106	459	1781	3336	263
Grp Volume(v), veh/h	247	0	0	291	0	0	48	281	284	16	303	311
Grp Sat Flow(s),veh/h/ln	1688	0	0	1755	0	0	1781	1777	1788	1781	1777	1823
Q Serve(g_s), s	8.3	0.0	0.0	9.4	0.0	0.0	1.6	8.3	8.4	0.5	9.4	9.5
Cycle Q Clear(g_c), s	8.3	0.0	0.0	9.4	0.0	0.0	1.6	8.3	8.4	0.5	9.4	9.5
Prop In Lane	0.28		0.52	0.54		0.21	1.00		0.26	1.00		0.14
Lane Grp Cap(c), veh/h	311	0	0	360	0	0	82	455	458	35	408	419
V/C Ratio(X)	0.79	0.00	0.00	0.81	0.00	0.00	0.59	0.62	0.62	0.46	0.74	0.74
Avail Cap(c_a), veh/h	509	0	0	529	0	0	149	565	569	149	565	580
HCM Platoon Ratio	1.00	1.00	1.00	1.00	1.00	1.00	1.00	1.00	1.00	1.00	1.00	1.00
Upstream Filter(I)	1.00	0.00	0.00	1.00	0.00	0.00	1.00	1.00	1.00	1.00	1.00	1.00
Uniform Delay (d), s/veh	23.3	0.0	0.0	22.6	0.0	0.0	27.9	19.6	19.6	29.0	21.3	21.4
Incr Delay (d2), s/veh	4.6	0.0	0.0	5.8	0.0	0.0	6.5	1.4	1.4	9.2	3.3	3.3
Initial Q Delay(d3),s/veh	0.0	0.0	0.0	0.0	0.0	0.0	0.0	0.0	0.0	0.0	0.0	0.0
%ile BackOfQ(50%),veh/ln	3.5	0.0	0.0	4.2	0.0	0.0	0.8	3.3	3.4	0.3	4.0	4.1
Unsig. Movement Delay, s/veh												
LnGrp Delay(d),s/veh	27.9	0.0	0.0	28.4	0.0	0.0	34.4	21.0	21.0	38.1	24.7	24.7
LnGrp LOS	C	A	A	C	A	A	C	C	C	D	C	C
Approach Vol, veh/h		247			291			613			630	
Approach Delay, s/veh		27.9			28.4			22.0			25.0	
Approach LOS		C			C			C			C	
Timer - Assigned Phs	1	2		4	5	6		8				
Phs Duration (G+Y+Rc), s	6.2	20.3		16.0	7.7	18.7		17.2				
Change Period (Y+Rc), s	5.0	5.0		5.0	5.0	5.0		5.0				
Max Green Setting (Gmax), s	5.0	19.0		18.0	5.0	19.0		18.0				
Max Q Clear Time (g_c+I1), s	2.5	10.4		10.3	3.6	11.5		11.4				
Green Ext Time (p_c), s	0.0	2.2		0.8	0.0	2.2		0.9				
Intersection Summary												
HCM 6th Ctrl Delay				24.9								
HCM 6th LOS				C								

Intersection												
Int Delay, s/veh	7.9											
Movement	EBL	EBT	EBR	WBL	WBT	WBR	NBL	NBT	NBR	SBL	SBT	SBR
Lane Configurations		↕			↕			↕			↕	
Traffic Vol, veh/h	4	42	23	67	45	8	7	9	46	23	9	1
Future Vol, veh/h	4	42	23	67	45	8	7	9	46	23	9	1
Conflicting Peds, #/hr	0	0	0	0	0	0	0	0	0	0	0	0
Sign Control	Stop	Stop	Stop	Stop	Stop	Stop	Free	Free	Free	Free	Free	Free
RT Channelized	-	-	None	-	-	None	-	-	None	-	-	None
Storage Length	-	-	-	-	-	-	-	-	-	-	-	-
Veh in Median Storage, #	-	0	-	-	0	-	-	0	-	-	0	-
Grade, %	-	0	-	-	0	-	-	0	-	-	0	-
Peak Hour Factor	79	79	79	79	79	79	79	79	79	79	79	79
Heavy Vehicles, %	2	2	2	2	2	2	2	2	2	2	2	2
Mvmt Flow	5	53	29	85	57	10	9	11	58	29	11	1

Major/Minor	Minor2		Minor1		Major1			Major2				
Conflicting Flow All	162	157	12	169	128	40	12	0	0	69	0	0
Stage 1	70	70	-	58	58	-	-	-	-	-	-	-
Stage 2	92	87	-	111	70	-	-	-	-	-	-	-
Critical Hdwy	7.12	6.52	6.22	7.12	6.52	6.22	4.12	-	-	4.12	-	-
Critical Hdwy Stg 1	6.12	5.52	-	6.12	5.52	-	-	-	-	-	-	-
Critical Hdwy Stg 2	6.12	5.52	-	6.12	5.52	-	-	-	-	-	-	-
Follow-up Hdwy	3.518	4.018	3.318	3.518	4.018	3.318	2.218	-	-	2.218	-	-
Pot Cap-1 Maneuver	803	735	1069	795	763	1031	1607	-	-	1532	-	-
Stage 1	940	837	-	954	847	-	-	-	-	-	-	-
Stage 2	915	823	-	894	837	-	-	-	-	-	-	-
Platoon blocked, %								-	-	-	-	-
Mov Cap-1 Maneuver	735	717	1069	716	744	1031	1607	-	-	1532	-	-
Mov Cap-2 Maneuver	735	717	-	716	744	-	-	-	-	-	-	-
Stage 1	934	821	-	948	842	-	-	-	-	-	-	-
Stage 2	840	818	-	798	821	-	-	-	-	-	-	-

Approach	EB	WB	NB	SB
HCM Control Delay, s	10	11.1	0.8	5.2
HCM LOS	B	B		

Minor Lane/Major Mvmt	NBL	NBT	NBR	EBLn1WBLn1	SBL	SBT	SBR
Capacity (veh/h)	1607	-	-	807	742	1532	-
HCM Lane V/C Ratio	0.006	-	-	0.108	0.205	0.019	-
HCM Control Delay (s)	7.3	0	-	10	11.1	7.4	0
HCM Lane LOS	A	A	-	B	B	A	A
HCM 95th %tile Q(veh)	0	-	-	0.4	0.8	0.1	-

Heritage at Dalia Ranch
6: Imperial Ave & Worthington Rd/Barioni Blvd

Opening Year 2024 + P1-2 Proj
Timing Plan: AM PEAK

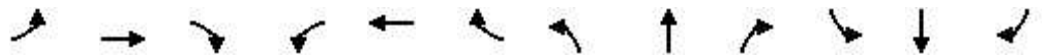

Movement	EBL	EBT	EBR	WBL	WBT	WBR	NBL	NBT	NBR	SBL	SBT	SBR
Lane Configurations		↕	↗		↕	↗	↖	↕↗		↖	↕↗	
Traffic Volume (veh/h)	71	138	215	55	133	84	94	501	51	54	727	56
Future Volume (veh/h)	71	138	215	55	133	84	94	501	51	54	727	56
Initial Q (Qb), veh	0	0	0	0	0	0	0	0	0	0	0	0
Ped-Bike Adj(A_pbT)	1.00		1.00	1.00		1.00	1.00		1.00	1.00		1.00
Parking Bus, Adj	1.00	1.00	1.00	1.00	1.00	1.00	1.00	1.00	1.00	1.00	1.00	1.00
Work Zone On Approach		No			No			No			No	
Adj Sat Flow, veh/h/ln	1870	1870	1870	1870	1870	1870	1870	1870	1870	1870	1870	1870
Adj Flow Rate, veh/h	80	155	242	62	149	94	106	563	57	61	817	63
Peak Hour Factor	0.89	0.89	0.89	0.89	0.89	0.89	0.89	0.89	0.89	0.89	0.89	0.89
Percent Heavy Veh, %	2	2	2	2	2	2	2	2	2	2	2	2
Cap, veh/h	121	235	307	83	200	243	134	980	99	91	924	71
Arrive On Green	0.19	0.19	0.19	0.15	0.15	0.15	0.08	0.30	0.30	0.05	0.28	0.28
Sat Flow, veh/h	626	1213	1585	542	1302	1585	1781	3259	329	1781	3343	258
Grp Volume(v), veh/h	235	0	242	211	0	94	106	306	314	61	434	446
Grp Sat Flow(s),veh/h/ln	1839	0	1585	1843	0	1585	1781	1777	1811	1781	1777	1824
Q Serve(g_s), s	7.8	0.0	9.6	7.3	0.0	3.5	3.9	9.7	9.7	2.2	15.5	15.5
Cycle Q Clear(g_c), s	7.8	0.0	9.6	7.3	0.0	3.5	3.9	9.7	9.7	2.2	15.5	15.5
Prop In Lane	0.34		1.00	0.29		1.00	1.00		0.18	1.00		0.14
Lane Grp Cap(c), veh/h	356	0	307	283	0	243	134	534	545	91	491	504
V/C Ratio(X)	0.66	0.00	0.79	0.75	0.00	0.39	0.79	0.57	0.58	0.67	0.88	0.88
Avail Cap(c_a), veh/h	498	0	429	499	0	429	134	534	545	134	508	522
HCM Platoon Ratio	1.00	1.00	1.00	1.00	1.00	1.00	1.00	1.00	1.00	1.00	1.00	1.00
Upstream Filter(l)	1.00	0.00	1.00	1.00	0.00	1.00	1.00	1.00	1.00	1.00	1.00	1.00
Uniform Delay (d), s/veh	24.8	0.0	25.5	26.9	0.0	25.3	30.2	19.6	19.6	31.0	23.0	23.0
Incr Delay (d2), s/veh	2.1	0.0	6.4	3.9	0.0	1.0	26.6	1.5	1.5	8.4	16.4	16.1
Initial Q Delay(d3),s/veh	0.0	0.0	0.0	0.0	0.0	0.0	0.0	0.0	0.0	0.0	0.0	0.0
%ile BackOfQ(50%),veh/ln	3.4	0.0	4.0	3.3	0.0	1.3	2.6	3.9	4.0	1.1	8.2	8.4
Unsig. Movement Delay, s/veh												
LnGrp Delay(d),s/veh	26.8	0.0	31.9	30.8	0.0	26.3	56.8	21.1	21.1	39.4	39.4	39.1
LnGrp LOS	C	A	C	C	A	C	E	C	C	D	D	D
Approach Vol, veh/h		477			305			726			941	
Approach Delay, s/veh		29.4			29.4			26.3			39.3	
Approach LOS		C			C			C			D	
Timer - Assigned Phs	1	2		4	5	6		8				
Phs Duration (G+Y+Rc), s	8.4	25.0		17.9	10.0	23.4		15.2				
Change Period (Y+Rc), s	5.0	5.0		5.0	5.0	5.0		5.0				
Max Green Setting (Gmax), s	5.0	19.0		18.0	5.0	19.0		18.0				
Max Q Clear Time (g_c+I1), s	4.2	11.7		11.6	5.9	17.5		9.3				
Green Ext Time (p_c), s	0.0	2.2		1.2	0.0	0.8		1.0				
Intersection Summary												
HCM 6th Ctrl Delay				32.3								
HCM 6th LOS				C								

Intersection

Intersection Delay, s/veh21.1
Intersection LOS C

Movement	EBL	EBT	EBR	WBL	WBT	WBR	NBL	NBT	NBR	SBL	SBT	SBR
Lane Configurations		↔	↔		↔	↔		↔			↔	
Traffic Vol, veh/h	68	395	121	11	305	78	0	0	1	107	31	79
Future Vol, veh/h	68	395	121	11	305	78	0	0	1	107	31	79
Peak Hour Factor	0.92	0.92	0.92	0.92	0.92	0.92	0.92	0.92	0.92	0.92	0.92	0.92
Heavy Vehicles, %	2	2	2	2	2	2	2	2	2	2	2	2
Mvmt Flow	74	429	132	12	332	85	0	0	1	116	34	86
Number of Lanes	0	1	1	0	1	1	0	1	0	0	1	0

Approach	EB	WB	NB	SB
Opposing Approach	WB	EB	SB	NB
Opposing Lanes	2	2	1	1
Conflicting Approach Left	SB	NB	EB	WB
Conflicting Lanes Left	1	1	2	2
Conflicting Approach Right	NB	SB	WB	EB
Conflicting Lanes Right	1	1	2	2
HCM Control Delay	27.4	15.8	9.7	13.8
HCM LOS	D	C	A	B

Lane	NBLn1	EBLn1	EBLn2	WBLn1	WBLn2	SBLn1
Vol Left, %	0%	15%	0%	3%	0%	49%
Vol Thru, %	0%	85%	0%	97%	0%	14%
Vol Right, %	100%	0%	100%	0%	100%	36%
Sign Control	Stop	Stop	Stop	Stop	Stop	Stop
Traffic Vol by Lane	1	463	121	316	78	217
LT Vol	0	68	0	11	0	107
Through Vol	0	395	0	305	0	31
RT Vol	1	0	121	0	78	79
Lane Flow Rate	1	503	132	343	85	236
Geometry Grp	2	7	7	7	7	2
Degree of Util (X)	0.002	0.836	0.19	0.589	0.128	0.413
Departure Headway (Hd)	6.71	5.982	5.197	6.171	5.442	6.302
Convergence, Y/N	Yes	Yes	Yes	Yes	Yes	Yes
Cap	537	604	688	584	656	568
Service Time	4.71	3.729	2.944	3.927	3.197	4.36
HCM Lane V/C Ratio	0.002	0.833	0.192	0.587	0.13	0.415
HCM Control Delay	9.7	32.1	9.2	17.5	9	13.8
HCM Lane LOS	A	D	A	C	A	B
HCM 95th-tile Q	0	8.9	0.7	3.8	0.4	2

Heritage at Dalia Ranch
8: Imperial Ave & Aten Rd

Opening Year 2024 + P1-2 Proj
Timing Plan: AM PEAK



Movement	EBL	EBT	EBR	WBL	WBT	WBR	NBL	NBT	NBR	SBL	SBT	SBR
Lane Configurations	↖	↖↗		↖	↖↗		↖	↖↗	↖	↖	↖↗	↖
Traffic Volume (veh/h)	195	342	64	132	303	149	62	368	68	158	740	395
Future Volume (veh/h)	195	342	64	132	303	149	62	368	68	158	740	395
Initial Q (Qb), veh	0	0	0	0	0	0	0	0	0	0	0	0
Ped-Bike Adj(A_pbT)	1.00		1.00	1.00		1.00	1.00		1.00	1.00		1.00
Parking Bus, Adj	1.00	1.00	1.00	1.00	1.00	1.00	1.00	1.00	1.00	1.00	1.00	1.00
Work Zone On Approach		No			No			No			No	
Adj Sat Flow, veh/h/ln	1870	1870	1870	1870	1870	1870	1870	1870	1870	1870	1870	1870
Adj Flow Rate, veh/h	227	398	74	153	352	173	72	428	79	184	860	459
Peak Hour Factor	0.86	0.86	0.86	0.86	0.86	0.86	0.86	0.86	0.86	0.86	0.86	0.86
Percent Heavy Veh, %	2	2	2	2	2	2	2	2	2	2	2	2
Cap, veh/h	257	704	130	191	461	223	96	901	402	206	1119	499
Arrive On Green	0.14	0.24	0.24	0.11	0.20	0.20	0.05	0.25	0.25	0.12	0.31	0.31
Sat Flow, veh/h	1781	2995	552	1781	2323	1122	1781	3554	1585	1781	3554	1585
Grp Volume(v), veh/h	227	235	237	153	268	257	72	428	79	184	860	459
Grp Sat Flow(s),veh/h/ln	1781	1777	1771	1781	1777	1668	1781	1777	1585	1781	1777	1585
Q Serve(g_s), s	8.7	8.1	8.2	5.8	9.9	10.1	2.8	7.1	2.7	7.1	15.2	19.4
Cycle Q Clear(g_c), s	8.7	8.1	8.2	5.8	9.9	10.1	2.8	7.1	2.7	7.1	15.2	19.4
Prop In Lane	1.00		0.31	1.00		0.67	1.00		1.00	1.00		1.00
Lane Grp Cap(c), veh/h	257	418	417	191	352	331	96	901	402	206	1119	499
V/C Ratio(X)	0.88	0.56	0.57	0.80	0.76	0.78	0.75	0.47	0.20	0.90	0.77	0.92
Avail Cap(c_a), veh/h	257	487	485	231	461	433	128	974	434	206	1128	503
HCM Platoon Ratio	1.00	1.00	1.00	1.00	1.00	1.00	1.00	1.00	1.00	1.00	1.00	1.00
Upstream Filter(l)	1.00	1.00	1.00	1.00	1.00	1.00	1.00	1.00	1.00	1.00	1.00	1.00
Uniform Delay (d), s/veh	29.1	23.4	23.4	30.2	26.2	26.3	32.3	22.0	20.3	30.3	21.5	22.9
Incr Delay (d2), s/veh	28.2	1.2	1.2	15.1	5.3	6.5	15.2	0.4	0.2	35.6	3.3	22.1
Initial Q Delay(d3),s/veh	0.0	0.0	0.0	0.0	0.0	0.0	0.0	0.0	0.0	0.0	0.0	0.0
%ile BackOfQ(50%),veh/ln	5.6	3.3	3.4	3.2	4.5	4.4	1.6	2.8	1.0	4.9	6.4	9.7
Unsig. Movement Delay, s/veh												
LnGrp Delay(d),s/veh	57.3	24.5	24.6	45.3	31.5	32.8	47.5	22.3	20.6	65.9	24.7	45.0
LnGrp LOS	E	C	C	D	C	C	D	C	C	E	C	D
Approach Vol, veh/h		699			678			579			1503	
Approach Delay, s/veh		35.2			35.1			25.2			36.0	
Approach LOS		D			D			C			D	
Timer - Assigned Phs	1	2	3	4	5	6	7	8				
Phs Duration (G+Y+Rc), s	3.0	22.6	12.4	21.3	8.8	26.8	15.0	18.8				
Change Period (Y+Rc), s	5.0	5.0	5.0	5.0	5.0	5.0	5.0	5.0				
Max Green Setting (Gmax), s	3.0	19.0	9.0	19.0	5.0	22.0	10.0	18.0				
Max Q Clear Time (g_c+1), s	19.0	9.1	7.8	10.2	4.8	21.4	10.7	12.1				
Green Ext Time (p_c), s	0.0	2.2	0.0	1.9	0.0	0.5	0.0	1.6				
Intersection Summary												
HCM 6th Ctrl Delay											33.9	
HCM 6th LOS											C	

Intersection						
Int Delay, s/veh	3.4					
Movement	EBL	EBT	WBT	WBR	SBL	SBR
Lane Configurations	↘	↑	↗		↘	↗
Traffic Vol, veh/h	3	113	112	38	111	7
Future Vol, veh/h	3	113	112	38	111	7
Conflicting Peds, #/hr	0	0	0	0	0	0
Sign Control	Free	Free	Free	Free	Stop	Stop
RT Channelized	-	None	-	None	-	None
Storage Length	50	-	-	-	0	0
Veh in Median Storage, #	-	0	0	-	0	-
Grade, %	-	0	0	-	0	-
Peak Hour Factor	92	92	92	92	92	92
Heavy Vehicles, %	2	2	2	2	2	2
Mvmt Flow	3	123	122	41	121	8

Major/Minor	Major1	Major2	Minor2		
Conflicting Flow All	163	0	-	0	272 143
Stage 1	-	-	-	-	143 -
Stage 2	-	-	-	-	129 -
Critical Hdwy	4.12	-	-	-	6.42 6.22
Critical Hdwy Stg 1	-	-	-	-	5.42 -
Critical Hdwy Stg 2	-	-	-	-	5.42 -
Follow-up Hdwy	2.218	-	-	-	3.518 3.318
Pot Cap-1 Maneuver	1416	-	-	-	717 905
Stage 1	-	-	-	-	884 -
Stage 2	-	-	-	-	897 -
Platoon blocked, %		-	-	-	
Mov Cap-1 Maneuver	1416	-	-	-	716 905
Mov Cap-2 Maneuver	-	-	-	-	716 -
Stage 1	-	-	-	-	882 -
Stage 2	-	-	-	-	897 -

Approach	EB	WB	SB
HCM Control Delay, s	0.2	0	10.9
HCM LOS			B

Minor Lane/Major Mvmt	EBL	EBT	WBT	WBR	SBLn1	SBLn2
Capacity (veh/h)	1416	-	-	-	716	905
HCM Lane V/C Ratio	0.002	-	-	-	0.169	0.008
HCM Control Delay (s)	7.5	-	-	-	11	9
HCM Lane LOS	A	-	-	-	B	A
HCM 95th %tile Q(veh)	0	-	-	-	0.6	0

Intersection						
Int Delay, s/veh	4.8					
Movement	WBL	WBR	NBT	NBR	SBL	SBT
Lane Configurations	↘	↗	↖		↘	↗
Traffic Vol, veh/h	30	0	10	10	0	4
Future Vol, veh/h	30	0	10	10	0	4
Conflicting Peds, #/hr	0	0	0	0	0	0
Sign Control	Stop	Stop	Free	Free	Free	Free
RT Channelized	-	None	-	None	-	None
Storage Length	0	0	-	-	50	-
Veh in Median Storage, #	0	-	0	-	-	0
Grade, %	0	-	0	-	-	0
Peak Hour Factor	92	92	92	92	92	92
Heavy Vehicles, %	2	2	2	2	2	2
Mvmt Flow	33	0	11	11	0	4

Major/Minor	Minor1	Major1	Major2			
Conflicting Flow All	21	17	0	0	22	0
Stage 1	17	-	-	-	-	-
Stage 2	4	-	-	-	-	-
Critical Hdwy	6.42	6.22	-	-	4.12	-
Critical Hdwy Stg 1	5.42	-	-	-	-	-
Critical Hdwy Stg 2	5.42	-	-	-	-	-
Follow-up Hdwy	3.518	3.318	-	-	2.218	-
Pot Cap-1 Maneuver	996	1062	-	-	1593	-
Stage 1	1006	-	-	-	-	-
Stage 2	1019	-	-	-	-	-
Platoon blocked, %			-	-		-
Mov Cap-1 Maneuver	996	1062	-	-	1593	-
Mov Cap-2 Maneuver	996	-	-	-	-	-
Stage 1	1006	-	-	-	-	-
Stage 2	1019	-	-	-	-	-

Approach	WB	NB	SB
HCM Control Delay, s	8.7	0	0
HCM LOS	A		

Minor Lane/Major Mvmt	NBT	NBRWBLn1WBLn2	SBL	SBT
Capacity (veh/h)	-	- 996	- 1593	-
HCM Lane V/C Ratio	-	- 0.033	-	-
HCM Control Delay (s)	-	- 8.7	0	0
HCM Lane LOS	-	- A	A	A
HCM 95th %tile Q(veh)	-	- 0.1	- 0	-

Intersection												
Int Delay, s/veh	0.3											
Movement	EBL	EBT	EBR	WBL	WBT	WBR	NBL	NBT	NBR	SBL	SBT	SBR
Lane Configurations		↕			↕		↕	↕		↕	↕	
Traffic Vol, veh/h	6	4	0	7	0	5	1	589	7	6	620	18
Future Vol, veh/h	6	4	0	7	0	5	1	589	7	6	620	18
Conflicting Peds, #/hr	0	0	0	0	0	0	0	0	0	0	0	0
Sign Control	Stop	Stop	Stop	Stop	Stop	Stop	Free	Free	Free	Free	Free	Free
RT Channelized	-	-	None	-	-	None	-	-	None	-	-	None
Storage Length	-	-	-	-	-	-	50	-	-	50	-	-
Veh in Median Storage, #	-	1	-	-	1	-	-	0	-	-	0	-
Grade, %	-	0	-	-	0	-	-	0	-	-	0	-
Peak Hour Factor	92	92	92	92	92	92	92	92	92	92	92	92
Heavy Vehicles, %	2	2	2	2	2	2	2	2	2	2	2	2
Mvmt Flow	7	4	0	8	0	5	1	640	8	7	674	20

Major/Minor	Minor2		Minor1		Major1			Major2				
Conflicting Flow All	1020	1348	347	999	1354	324	694	0	0	648	0	0
Stage 1	698	698	-	646	646	-	-	-	-	-	-	-
Stage 2	322	650	-	353	708	-	-	-	-	-	-	-
Critical Hdwy	7.54	6.54	6.94	7.54	6.54	6.94	4.14	-	-	4.14	-	-
Critical Hdwy Stg 1	6.54	5.54	-	6.54	5.54	-	-	-	-	-	-	-
Critical Hdwy Stg 2	6.54	5.54	-	6.54	5.54	-	-	-	-	-	-	-
Follow-up Hdwy	3.52	4.02	3.32	3.52	4.02	3.32	2.22	-	-	2.22	-	-
Pot Cap-1 Maneuver	191	150	649	198	148	672	897	-	-	934	-	-
Stage 1	397	440	-	427	465	-	-	-	-	-	-	-
Stage 2	664	463	-	637	436	-	-	-	-	-	-	-
Platoon blocked, %								-	-	-	-	-
Mov Cap-1 Maneuver	188	149	649	194	147	672	897	-	-	934	-	-
Mov Cap-2 Maneuver	303	272	-	315	271	-	-	-	-	-	-	-
Stage 1	397	437	-	427	465	-	-	-	-	-	-	-
Stage 2	658	463	-	626	433	-	-	-	-	-	-	-

Approach	EB		WB		NB		SB	
HCM Control Delay, s	17.9		14.2		0		0.1	
HCM LOS	C		B					

Minor Lane/Major Mvmt	NBL	NBT	NBR	EBLn1	WBLn1	SBL	SBT	SBR
Capacity (veh/h)	897	-	-	290	405	934	-	-
HCM Lane V/C Ratio	0.001	-	-	0.037	0.032	0.007	-	-
HCM Control Delay (s)	9	-	-	17.9	14.2	8.9	-	-
HCM Lane LOS	A	-	-	C	B	A	-	-
HCM 95th %tile Q(veh)	0	-	-	0.1	0.1	0	-	-

Intersection						
Int Delay, s/veh	0.7					
Movement	WBL	WBR	NBT	NBR	SBL	SBT
Lane Configurations	↔		↑↓		↔	↑↑
Traffic Vol, veh/h	20	10	590	30	30	583
Future Vol, veh/h	20	10	590	30	30	583
Conflicting Peds, #/hr	0	0	0	0	0	0
Sign Control	Stop	Stop	Free	Free	Free	Free
RT Channelized	-	None	-	None	-	None
Storage Length	0	-	-	-	140	-
Veh in Median Storage, #	0	-	0	-	-	0
Grade, %	0	-	0	-	-	0
Peak Hour Factor	91	91	91	91	91	91
Heavy Vehicles, %	2	2	2	2	2	2
Mvmt Flow	22	11	648	33	33	641

Major/Minor	Minor1	Major1	Major2		
Conflicting Flow All	1052	341	0	0	681
Stage 1	665	-	-	-	-
Stage 2	387	-	-	-	-
Critical Hdwy	6.84	6.94	-	-	4.14
Critical Hdwy Stg 1	5.84	-	-	-	-
Critical Hdwy Stg 2	5.84	-	-	-	-
Follow-up Hdwy	3.52	3.32	-	-	2.22
Pot Cap-1 Maneuver	222	655	-	-	907
Stage 1	473	-	-	-	-
Stage 2	656	-	-	-	-
Platoon blocked, %			-	-	-
Mov Cap-1 Maneuver	214	655	-	-	907
Mov Cap-2 Maneuver	214	-	-	-	-
Stage 1	473	-	-	-	-
Stage 2	632	-	-	-	-

Approach	WB	NB	SB
HCM Control Delay, s	19.8	0	0.4
HCM LOS	C		

Minor Lane/Major Mvmt	NBT	NBRWBLn1	SBL	SBT
Capacity (veh/h)	-	-	276	907
HCM Lane V/C Ratio	-	-	0.119	0.036
HCM Control Delay (s)	-	-	19.8	9.1
HCM Lane LOS	-	-	C	A
HCM 95th %tile Q(veh)	-	-	0.4	0.1

Intersection												
Int Delay, s/veh	7.5											
Movement	EBL	EBT	EBR	WBL	WBT	WBR	NBL	NBT	NBR	SBL	SBT	SBR
Lane Configurations		↕			↕			↕			↕	
Traffic Vol, veh/h	2	39	8	28	45	26	5	14	18	14	10	7
Future Vol, veh/h	2	39	8	28	45	26	5	14	18	14	10	7
Conflicting Peds, #/hr	0	0	0	0	0	0	0	0	0	0	0	0
Sign Control	Stop	Stop	Stop	Stop	Stop	Stop	Free	Free	Free	Free	Free	Free
RT Channelized	-	-	None	-	-	None	-	-	None	-	-	None
Storage Length	-	-	-	-	-	-	-	-	-	-	-	-
Veh in Median Storage, #	-	0	-	-	0	-	-	0	-	-	0	-
Grade, %	-	0	-	-	0	-	-	0	-	-	0	-
Peak Hour Factor	79	79	79	79	79	79	79	79	79	79	79	79
Heavy Vehicles, %	2	2	2	2	2	2	2	2	2	2	2	2
Mvmt Flow	3	49	10	35	57	33	6	18	23	18	13	9

Major/Minor	Minor2		Minor1		Major1			Major2				
Conflicting Flow All	141	107	18	125	100	30	22	0	0	41	0	0
Stage 1	54	54	-	42	42	-	-	-	-	-	-	-
Stage 2	87	53	-	83	58	-	-	-	-	-	-	-
Critical Hdwy	7.12	6.52	6.22	7.12	6.52	6.22	4.12	-	-	4.12	-	-
Critical Hdwy Stg 1	6.12	5.52	-	6.12	5.52	-	-	-	-	-	-	-
Critical Hdwy Stg 2	6.12	5.52	-	6.12	5.52	-	-	-	-	-	-	-
Follow-up Hdwy	3.518	4.018	3.318	3.518	4.018	3.318	2.218	-	-	2.218	-	-
Pot Cap-1 Maneuver	829	783	1061	849	790	1044	1593	-	-	1568	-	-
Stage 1	958	850	-	972	860	-	-	-	-	-	-	-
Stage 2	921	851	-	925	847	-	-	-	-	-	-	-
Platoon blocked, %								-	-	-	-	-
Mov Cap-1 Maneuver	749	770	1061	790	777	1044	1593	-	-	1568	-	-
Mov Cap-2 Maneuver	749	770	-	790	777	-	-	-	-	-	-	-
Stage 1	954	840	-	968	857	-	-	-	-	-	-	-
Stage 2	829	848	-	852	837	-	-	-	-	-	-	-

Approach	EB		WB		NB		SB	
HCM Control Delay, s	9.8		10.1		1		3.3	
HCM LOS	A		B					

Minor Lane/Major Mvmt	NBL	NBT	NBR	EBLn1	WBLn1	SBL	SBT	SBR
Capacity (veh/h)	1593	-	-	805	837	1568	-	-
HCM Lane V/C Ratio	0.004	-	-	0.077	0.15	0.011	-	-
HCM Control Delay (s)	7.3	0	-	9.8	10.1	7.3	0	-
HCM Lane LOS	A	A	-	A	B	A	A	-
HCM 95th %tile Q(veh)	0	-	-	0.2	0.5	0	-	-

Heritage at Dalia Ranch
7: La Brucherie Rd & Worthington Rd

Opening Year 2024 + P1-2 Proj
Timing Plan: PM PEAK

Intersection												
Intersection Delay, s/veh	11											
Intersection LOS	B											

Movement	EBL	EBT	EBR	WBL	WBT	WBR	NBL	NBT	NBR	SBL	SBT	SBR
Lane Configurations		↔	↔		↔	↔		↔			↔	
Traffic Vol, veh/h	42	190	33	27	218	34	1	0	0	38	5	34
Future Vol, veh/h	42	190	33	27	218	34	1	0	0	38	5	34
Peak Hour Factor	0.80	0.80	0.80	0.80	0.80	0.80	0.80	0.80	0.80	0.80	0.80	0.80
Heavy Vehicles, %	2	2	2	2	2	2	2	2	2	2	2	2
Mvmt Flow	53	238	41	34	273	43	1	0	0	48	6	43
Number of Lanes	0	1	1	0	1	1	0	1	0	0	1	0

Approach	EB	WB	NB	SB
Opposing Approach	WB	EB	SB	NB
Opposing Lanes	2	2	1	1
Conflicting Approach Left	SB	NB	EB	WB
Conflicting Lanes Left	1	1	2	2
Conflicting Approach Right	NB	SB	WB	EB
Conflicting Lanes Right	1	1	2	2
HCM Control Delay	11.1	11.3	9	9.3
HCM LOS	B	B	A	A

Lane	NBLn1	EBLn1	EBLn2	WBLn1	WBLn2	SBLn1
Vol Left, %	100%	18%	0%	11%	0%	49%
Vol Thru, %	0%	82%	0%	89%	0%	6%
Vol Right, %	0%	0%	100%	0%	100%	44%
Sign Control	Stop	Stop	Stop	Stop	Stop	Stop
Traffic Vol by Lane	1	232	33	245	34	77
LT Vol	1	42	0	27	0	38
Through Vol	0	190	0	218	0	5
RT Vol	0	0	33	0	34	34
Lane Flow Rate	1	290	41	306	42	96
Geometry Grp	2	7	7	7	7	2
Degree of Util (X)	0.002	0.418	0.05	0.437	0.052	0.143
Departure Headway (Hd)	5.882	5.186	4.391	5.138	4.378	5.331
Convergence, Y/N	Yes	Yes	Yes	Yes	Yes	Yes
Cap	604	693	812	698	815	670
Service Time	3.963	2.932	2.136	2.882	2.122	3.387
HCM Lane V/C Ratio	0.002	0.418	0.05	0.438	0.052	0.143
HCM Control Delay	9	11.6	7.4	11.8	7.4	9.3
HCM Lane LOS	A	B	A	B	A	A
HCM 95th-tile Q	0	2.1	0.2	2.2	0.2	0.5

Intersection						
Int Delay, s/veh	2.4					
Movement	EBL	EBT	WBT	WBR	SBL	SBR
Lane Configurations	↔	↑	↔		↔	↔
Traffic Vol, veh/h	8	57	84	126	72	5
Future Vol, veh/h	8	57	84	126	72	5
Conflicting Peds, #/hr	0	0	0	0	0	0
Sign Control	Free	Free	Free	Free	Stop	Stop
RT Channelized	-	None	-	None	-	None
Storage Length	50	-	-	-	0	0
Veh in Median Storage, #	-	0	0	-	0	-
Grade, %	-	0	0	-	0	-
Peak Hour Factor	92	92	92	92	92	92
Heavy Vehicles, %	2	2	2	2	2	2
Mvmt Flow	9	62	91	137	78	5

Major/Minor	Major1	Major2	Minor2		
Conflicting Flow All	228	0	-	0	240 160
Stage 1	-	-	-	-	160 -
Stage 2	-	-	-	-	80 -
Critical Hdwy	4.12	-	-	-	6.42 6.22
Critical Hdwy Stg 1	-	-	-	-	5.42 -
Critical Hdwy Stg 2	-	-	-	-	5.42 -
Follow-up Hdwy	2.218	-	-	-	3.518 3.318
Pot Cap-1 Maneuver	1340	-	-	-	748 885
Stage 1	-	-	-	-	869 -
Stage 2	-	-	-	-	943 -
Platoon blocked, %		-	-	-	
Mov Cap-1 Maneuver	1340	-	-	-	743 885
Mov Cap-2 Maneuver	-	-	-	-	743 -
Stage 1	-	-	-	-	863 -
Stage 2	-	-	-	-	943 -

Approach	EB	WB	SB
HCM Control Delay, s	0.9	0	10.3
HCM LOS			B

Minor Lane/Major Mvmt	EBL	EBT	WBT	WBR	SBLn1	SBLn2
Capacity (veh/h)	1340	-	-	-	743	885
HCM Lane V/C Ratio	0.006	-	-	-	0.105	0.006
HCM Control Delay (s)	7.7	-	-	-	10.4	9.1
HCM Lane LOS	A	-	-	-	B	A
HCM 95th %tile Q(veh)	0	-	-	-	0.4	0

Intersection						
Int Delay, s/veh	2.2					
Movement	WBL	WBR	NBT	NBR	SBL	SBT
Lane Configurations	↖	↗	↖		↖	↗
Traffic Vol, veh/h	19	0	9	34	0	13
Future Vol, veh/h	19	0	9	34	0	13
Conflicting Peds, #/hr	0	0	0	0	0	0
Sign Control	Stop	Stop	Free	Free	Free	Free
RT Channelized	-	None	-	None	-	None
Storage Length	0	0	-	-	50	-
Veh in Median Storage, #	0	-	0	-	-	0
Grade, %	0	-	0	-	-	0
Peak Hour Factor	92	92	92	92	92	92
Heavy Vehicles, %	2	2	2	2	2	2
Mvmt Flow	21	0	10	37	0	14

Major/Minor	Minor1	Major1	Major2		
Conflicting Flow All	43	29	0	0	47
Stage 1	29	-	-	-	-
Stage 2	14	-	-	-	-
Critical Hdwy	6.42	6.22	-	-	4.12
Critical Hdwy Stg 1	5.42	-	-	-	-
Critical Hdwy Stg 2	5.42	-	-	-	-
Follow-up Hdwy	3.518	3.318	-	-	2.218
Pot Cap-1 Maneuver	968	1046	-	-	1560
Stage 1	994	-	-	-	-
Stage 2	1009	-	-	-	-
Platoon blocked, %			-	-	-
Mov Cap-1 Maneuver	968	1046	-	-	1560
Mov Cap-2 Maneuver	968	-	-	-	-
Stage 1	994	-	-	-	-
Stage 2	1009	-	-	-	-

Approach	WB	NB	SB
HCM Control Delay, s	8.8	0	0
HCM LOS	A		

Minor Lane/Major Mvmt	NBT	NBRWBLn1	WBLn2	SBL	SBT
Capacity (veh/h)	-	-	968	-	1560
HCM Lane V/C Ratio	-	-	0.021	-	-
HCM Control Delay (s)	-	-	8.8	0	0
HCM Lane LOS	-	-	A	A	A
HCM 95th %tile Q(veh)	-	-	0.1	-	0

Heritage at Dalia Ranch
1: SR-86 & Keystone Rd

Opening Year 2026
Timing Plan: AM PEAK

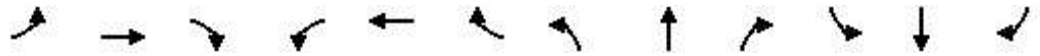

Movement	EBL	EBT	EBR	WBL	WBT	WBR	NBL	NBT	NBR	SBL	SBT	SBR
Lane Configurations		↔			↔		↗	↕	↗	↗	↕	↗
Traffic Volume (veh/h)	34	34	12	19	25	44	19	485	51	47	543	39
Future Volume (veh/h)	34	34	12	19	25	44	19	485	51	47	543	39
Initial Q (Qb), veh	0	0	0	0	0	0	0	0	0	0	0	0
Ped-Bike Adj(A_pbT)	1.00		1.00	1.00		1.00	1.00		1.00	1.00		1.00
Parking Bus, Adj	1.00	1.00	1.00	1.00	1.00	1.00	1.00	1.00	1.00	1.00	1.00	1.00
Work Zone On Approach		No			No			No			No	
Adj Sat Flow, veh/h/ln	1870	1870	1870	1870	1870	1870	1870	1870	1870	1870	1870	1870
Adj Flow Rate, veh/h	38	38	13	21	28	49	21	539	57	52	603	43
Peak Hour Factor	0.90	0.90	0.90	0.90	0.90	0.90	0.90	0.90	0.90	0.90	0.90	0.90
Percent Heavy Veh, %	2	2	2	2	2	2	2	2	2	2	2	2
Cap, veh/h	254	110	32	184	75	110	48	1057	471	105	1170	522
Arrive On Green	0.13	0.13	0.13	0.13	0.13	0.13	0.03	0.30	0.30	0.06	0.33	0.33
Sat Flow, veh/h	592	827	243	264	560	824	1781	3554	1585	1781	3554	1585
Grp Volume(v), veh/h	89	0	0	98	0	0	21	539	57	52	603	43
Grp Sat Flow(s),veh/h/ln	1661	0	0	1648	0	0	1781	1777	1585	1781	1777	1585
Q Serve(g_s), s	0.0	0.0	0.0	0.2	0.0	0.0	0.3	3.7	0.8	0.8	4.0	0.5
Cycle Q Clear(g_c), s	1.3	0.0	0.0	1.5	0.0	0.0	0.3	3.7	0.8	0.8	4.0	0.5
Prop In Lane	0.43		0.15	0.21		0.50	1.00		1.00	1.00		1.00
Lane Grp Cap(c), veh/h	396	0	0	368	0	0	48	1057	471	105	1170	522
V/C Ratio(X)	0.22	0.00	0.00	0.27	0.00	0.00	0.44	0.51	0.12	0.50	0.52	0.08
Avail Cap(c_a), veh/h	1142	0	0	1134	0	0	303	2178	971	303	2178	971
HCM Platoon Ratio	1.00	1.00	1.00	1.00	1.00	1.00	1.00	1.00	1.00	1.00	1.00	1.00
Upstream Filter(l)	1.00	0.00	0.00	1.00	0.00	0.00	1.00	1.00	1.00	1.00	1.00	1.00
Uniform Delay (d), s/veh	11.6	0.0	0.0	11.7	0.0	0.0	14.1	8.5	7.5	13.4	8.0	6.8
Incr Delay (d2), s/veh	0.3	0.0	0.0	0.4	0.0	0.0	6.2	0.4	0.1	3.6	0.4	0.1
Initial Q Delay(d3),s/veh	0.0	0.0	0.0	0.0	0.0	0.0	0.0	0.0	0.0	0.0	0.0	0.0
%ile BackOfQ(50%),veh/ln	0.4	0.0	0.0	0.5	0.0	0.0	0.2	1.0	0.2	0.4	1.0	0.1
Unsig. Movement Delay, s/veh												
LnGrp Delay(d),s/veh	11.9	0.0	0.0	12.1	0.0	0.0	20.3	8.9	7.6	17.0	8.3	6.9
LnGrp LOS	B	A	A	B	A	A	C	A	A	B	A	A
Approach Vol, veh/h		89			98			617			698	
Approach Delay, s/veh		11.9			12.1			9.2			8.9	
Approach LOS		B			B			A			A	
Timer - Assigned Phs	1	2		4	5	6		8				
Phs Duration (G+Y+Rc), s	6.7	13.7		8.9	5.8	14.7		8.9				
Change Period (Y+Rc), s	5.0	5.0		5.0	5.0	5.0		5.0				
Max Green Setting (Gmax), s	5.0	18.0		18.0	5.0	18.0		18.0				
Max Q Clear Time (g_c+I1), s	2.8	5.7		3.3	2.3	6.0		3.5				
Green Ext Time (p_c), s	0.0	3.0		0.3	0.0	3.3		0.4				
Intersection Summary												
HCM 6th Ctrl Delay				9.4								
HCM 6th LOS				A								

Intersection												
Int Delay, s/veh	0.4											
Movement	EBL	EBT	EBR	WBL	WBT	WBR	NBL	NBT	NBR	SBL	SBT	SBR
Lane Configurations		↕			↕		↕	↕		↕	↕	
Traffic Vol, veh/h	20	3	2	1	2	5	0	554	1	1	548	8
Future Vol, veh/h	20	3	2	1	2	5	0	554	1	1	548	8
Conflicting Peds, #/hr	0	0	0	0	0	0	0	0	0	0	0	0
Sign Control	Stop	Stop	Stop	Stop	Stop	Stop	Free	Free	Free	Free	Free	Free
RT Channelized	-	-	None	-	-	None	-	-	None	-	-	None
Storage Length	-	-	-	-	-	-	50	-	-	50	-	-
Veh in Median Storage, #	-	1	-	-	1	-	-	0	-	-	0	-
Grade, %	-	0	-	-	0	-	-	0	-	-	0	-
Peak Hour Factor	94	94	94	94	94	94	94	94	94	94	94	94
Heavy Vehicles, %	2	2	2	2	2	2	2	2	2	2	2	2
Mvmt Flow	21	3	2	1	2	5	0	589	1	1	583	9

Major/Minor	Minor2		Minor1		Major1			Major2				
Conflicting Flow All	886	1180	296	885	1184	295	592	0	0	590	0	0
Stage 1	590	590	-	590	590	-	-	-	-	-	-	-
Stage 2	296	590	-	295	594	-	-	-	-	-	-	-
Critical Hdwy	7.54	6.54	6.94	7.54	6.54	6.94	4.14	-	-	4.14	-	-
Critical Hdwy Stg 1	6.54	5.54	-	6.54	5.54	-	-	-	-	-	-	-
Critical Hdwy Stg 2	6.54	5.54	-	6.54	5.54	-	-	-	-	-	-	-
Follow-up Hdwy	3.52	4.02	3.32	3.52	4.02	3.32	2.22	-	-	2.22	-	-
Pot Cap-1 Maneuver	239	189	700	239	188	701	980	-	-	982	-	-
Stage 1	461	493	-	461	493	-	-	-	-	-	-	-
Stage 2	688	493	-	689	491	-	-	-	-	-	-	-
Platoon blocked, %								-	-	-	-	-
Mov Cap-1 Maneuver	236	189	700	236	188	701	980	-	-	982	-	-
Mov Cap-2 Maneuver	352	311	-	352	310	-	-	-	-	-	-	-
Stage 1	461	493	-	461	493	-	-	-	-	-	-	-
Stage 2	680	493	-	682	491	-	-	-	-	-	-	-

Approach	EB		WB		NB		SB	
HCM Control Delay, s	15.8		12.5		0		0	
HCM LOS	C		B					

Minor Lane/Major Mvmt	NBL	NBT	NBR	EBLn1	WBLn1	SBL	SBT	SBR
Capacity (veh/h)	980	-	-	361	487	982	-	-
HCM Lane V/C Ratio	-	-	-	0.074	0.017	0.001	-	-
HCM Control Delay (s)	0	-	-	15.8	12.5	8.7	-	-
HCM Lane LOS	A	-	-	C	B	A	-	-
HCM 95th %tile Q(veh)	0	-	-	0.2	0.1	0	-	-

Intersection						
Int Delay, s/veh	1.6					
Movement	WBL	WBR	NBT	NBR	SBL	SBT
Lane Configurations	↔		↑↓		↔	↑↑
Traffic Vol, veh/h	61	24	532	43	20	530
Future Vol, veh/h	61	24	532	43	20	530
Conflicting Peds, #/hr	0	0	0	0	0	0
Sign Control	Stop	Stop	Free	Free	Free	Free
RT Channelized	-	None	-	None	-	None
Storage Length	0	-	-	-	140	-
Veh in Median Storage, #	0	-	0	-	-	0
Grade, %	0	-	0	-	-	0
Peak Hour Factor	91	91	91	91	91	91
Heavy Vehicles, %	2	2	2	2	2	2
Mvmt Flow	67	26	585	47	22	582

Major/Minor	Minor1	Major1	Major2			
Conflicting Flow All	944	316	0	0	632	0
Stage 1	609	-	-	-	-	-
Stage 2	335	-	-	-	-	-
Critical Hdwy	6.84	6.94	-	-	4.14	-
Critical Hdwy Stg 1	5.84	-	-	-	-	-
Critical Hdwy Stg 2	5.84	-	-	-	-	-
Follow-up Hdwy	3.52	3.32	-	-	2.22	-
Pot Cap-1 Maneuver	261	680	-	-	947	-
Stage 1	505	-	-	-	-	-
Stage 2	697	-	-	-	-	-
Platoon blocked, %			-	-		
Mov Cap-1 Maneuver	255	680	-	-	947	-
Mov Cap-2 Maneuver	255	-	-	-	-	-
Stage 1	505	-	-	-	-	-
Stage 2	681	-	-	-	-	-

Approach	WB	NB	SB
HCM Control Delay, s	21.5	0	0.3
HCM LOS	C		

Minor Lane/Major Mvmt	NBT	NBRWBLn1	SBL	SBT
Capacity (veh/h)	-	-	310	947
HCM Lane V/C Ratio	-	-	0.301	0.023
HCM Control Delay (s)	-	-	21.5	8.9
HCM Lane LOS	-	-	C	A
HCM 95th %tile Q(veh)	-	-	1.2	0.1

Heritage at Dalia Ranch
4: Imperial Ave & Neckel Rd

Opening Year 2026
Timing Plan: AM PEAK

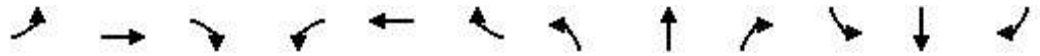

Movement	EBL	EBT	EBR	WBL	WBT	WBR	NBL	NBT	NBR	SBL	SBT	SBR
Lane Configurations		↕			↕		↕	↕		↕	↕	
Traffic Volume (veh/h)	35	45	13	228	66	85	9	461	95	24	533	32
Future Volume (veh/h)	35	45	13	228	66	85	9	461	95	24	533	32
Initial Q (Qb), veh	0	0	0	0	0	0	0	0	0	0	0	0
Ped-Bike Adj(A_pbT)	1.00		1.00	1.00		1.00	1.00		1.00	1.00		1.00
Parking Bus, Adj	1.00	1.00	1.00	1.00	1.00	1.00	1.00	1.00	1.00	1.00	1.00	1.00
Work Zone On Approach		No			No			No			No	
Adj Sat Flow, veh/h/ln	1870	1870	1870	1870	1870	1870	1870	1870	1870	1870	1870	1870
Adj Flow Rate, veh/h	38	49	14	251	73	93	10	507	104	26	586	35
Peak Hour Factor	0.91	0.91	0.91	0.91	0.91	0.91	0.91	0.91	0.91	0.91	0.91	0.91
Percent Heavy Veh, %	2	2	2	2	2	2	2	2	2	2	2	2
Cap, veh/h	52	67	19	294	86	109	23	710	145	53	881	53
Arrive On Green	0.08	0.08	0.08	0.28	0.28	0.28	0.01	0.24	0.24	0.03	0.26	0.26
Sat Flow, veh/h	674	869	248	1052	306	390	1781	2939	600	1781	3407	203
Grp Volume(v), veh/h	101	0	0	417	0	0	10	306	305	26	305	316
Grp Sat Flow(s),veh/h/ln	1792	0	0	1748	0	0	1781	1777	1762	1781	1777	1834
Q Serve(g_s), s	3.0	0.0	0.0	12.1	0.0	0.0	0.3	8.5	8.6	0.8	8.3	8.3
Cycle Q Clear(g_c), s	3.0	0.0	0.0	12.1	0.0	0.0	0.3	8.5	8.6	0.8	8.3	8.3
Prop In Lane	0.38		0.14	0.60		0.22	1.00		0.34	1.00		0.11
Lane Grp Cap(c), veh/h	138	0	0	489	0	0	23	429	426	53	459	474
V/C Ratio(X)	0.73	0.00	0.00	0.85	0.00	0.00	0.44	0.71	0.72	0.49	0.66	0.67
Avail Cap(c_a), veh/h	600	0	0	585	0	0	166	628	623	166	628	648
HCM Platoon Ratio	1.00	1.00	1.00	1.00	1.00	1.00	1.00	1.00	1.00	1.00	1.00	1.00
Upstream Filter(l)	1.00	0.00	0.00	1.00	0.00	0.00	1.00	1.00	1.00	1.00	1.00	1.00
Uniform Delay (d), s/veh	24.3	0.0	0.0	18.3	0.0	0.0	26.4	18.7	18.7	25.7	17.9	17.9
Incr Delay (d2), s/veh	7.3	0.0	0.0	10.2	0.0	0.0	12.4	2.2	2.3	6.8	1.7	1.6
Initial Q Delay(d3),s/veh	0.0	0.0	0.0	0.0	0.0	0.0	0.0	0.0	0.0	0.0	0.0	0.0
%ile BackOfQ(50%),veh/ln	1.4	0.0	0.0	5.7	0.0	0.0	0.2	3.4	3.4	0.4	3.2	3.3
Unsig. Movement Delay, s/veh												
LnGrp Delay(d),s/veh	31.6	0.0	0.0	28.5	0.0	0.0	38.8	20.9	21.0	32.4	19.5	19.5
LnGrp LOS	C	A	A	C	A	A	D	C	C	C	B	B
Approach Vol, veh/h		101			417			621				647
Approach Delay, s/veh		31.6			28.5			21.2				20.0
Approach LOS		C			C			C				C
Timer - Assigned Phs	1	2		4	5	6		8				
Phs Duration (G+Y+Rc), s	6.6	18.0		9.1	5.7	18.9		20.1				
Change Period (Y+Rc), s	5.0	5.0		5.0	5.0	5.0		5.0				
Max Green Setting (Gmax), s	5.0	19.0		18.0	5.0	19.0		18.0				
Max Q Clear Time (g_c+I1), s	2.8	10.6		5.0	2.3	10.3		14.1				
Green Ext Time (p_c), s	0.0	2.4		0.3	0.0	2.5		0.9				
Intersection Summary												
HCM 6th Ctrl Delay				23.1								
HCM 6th LOS				C								

Intersection												
Int Delay, s/veh	7.7											
Movement	EBL	EBT	EBR	WBL	WBT	WBR	NBL	NBT	NBR	SBL	SBT	SBR
Lane Configurations		↕			↕			↕			↕	
Traffic Vol, veh/h	4	43	24	62	46	0	8	6	44	1	2	1
Future Vol, veh/h	4	43	24	62	46	0	8	6	44	1	2	1
Conflicting Peds, #/hr	0	0	0	0	0	0	0	0	0	0	0	0
Sign Control	Stop	Stop	Stop	Stop	Stop	Stop	Free	Free	Free	Free	Free	Free
RT Channelized	-	-	None	-	-	None	-	-	None	-	-	None
Storage Length	-	-	-	-	-	-	-	-	-	-	-	-
Veh in Median Storage, #	-	0	-	-	0	-	-	0	-	-	0	-
Grade, %	-	0	-	-	0	-	-	0	-	-	0	-
Peak Hour Factor	79	79	79	79	79	79	79	79	79	79	79	79
Heavy Vehicles, %	2	2	2	2	2	2	2	2	2	2	2	2
Mvmt Flow	5	54	30	78	58	0	10	8	56	1	3	1

Major/Minor	Minor2		Minor1		Major1			Major2				
Conflicting Flow All	91	90	4	104	62	36	4	0	0	64	0	0
Stage 1	6	6	-	56	56	-	-	-	-	-	-	-
Stage 2	85	84	-	48	6	-	-	-	-	-	-	-
Critical Hdwy	7.12	6.52	6.22	7.12	6.52	6.22	4.12	-	-	4.12	-	-
Critical Hdwy Stg 1	6.12	5.52	-	6.12	5.52	-	-	-	-	-	-	-
Critical Hdwy Stg 2	6.12	5.52	-	6.12	5.52	-	-	-	-	-	-	-
Follow-up Hdwy	3.518	4.018	3.318	3.518	4.018	3.318	2.218	-	-	2.218	-	-
Pot Cap-1 Maneuver	893	800	1080	876	829	1037	1618	-	-	1538	-	-
Stage 1	1016	891	-	956	848	-	-	-	-	-	-	-
Stage 2	923	825	-	965	891	-	-	-	-	-	-	-
Platoon blocked, %								-	-	-	-	-
Mov Cap-1 Maneuver	840	794	1080	802	823	1037	1618	-	-	1538	-	-
Mov Cap-2 Maneuver	840	794	-	802	823	-	-	-	-	-	-	-
Stage 1	1010	890	-	950	843	-	-	-	-	-	-	-
Stage 2	854	820	-	880	890	-	-	-	-	-	-	-

Approach	EB		WB		NB		SB	
HCM Control Delay, s	9.6		10.3		1		1.8	
HCM LOS	A		B					

Minor Lane/Major Mvmt	NBL	NBT	NBR	EBLn1	WBLn1	SBL	SBT	SBR
Capacity (veh/h)	1618	-	-	875	811	1538	-	-
HCM Lane V/C Ratio	0.006	-	-	0.103	0.169	0.001	-	-
HCM Control Delay (s)	7.2	0	-	9.6	10.3	7.3	0	-
HCM Lane LOS	A	A	-	A	B	A	A	-
HCM 95th %tile Q(veh)	0	-	-	0.3	0.6	0	-	-

Heritage at Dalia Ranch
6: Imperial Ave & Worthington Rd/Barioni Blvd

Opening Year 2026
Timing Plan: AM PEAK

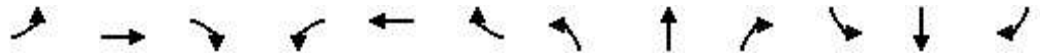

Movement	EBL	EBT	EBR	WBL	WBT	WBR	NBL	NBT	NBR	SBL	SBT	SBR
Lane Configurations		↕	↗		↕	↗	↖	↕↗		↖	↕↗	
Traffic Volume (veh/h)	78	142	221	57	137	80	96	508	53	41	724	71
Future Volume (veh/h)	78	142	221	57	137	80	96	508	53	41	724	71
Initial Q (Qb), veh	0	0	0	0	0	0	0	0	0	0	0	0
Ped-Bike Adj(A_pbT)	1.00		1.00	1.00		1.00	1.00		1.00	1.00		1.00
Parking Bus, Adj	1.00	1.00	1.00	1.00	1.00	1.00	1.00	1.00	1.00	1.00	1.00	1.00
Work Zone On Approach		No			No			No			No	
Adj Sat Flow, veh/h/ln	1870	1870	1870	1870	1870	1870	1870	1870	1870	1870	1870	1870
Adj Flow Rate, veh/h	88	160	248	64	154	90	108	571	60	46	813	80
Peak Hour Factor	0.89	0.89	0.89	0.89	0.89	0.89	0.89	0.89	0.89	0.89	0.89	0.89
Percent Heavy Veh, %	2	2	2	2	2	2	2	2	2	2	2	2
Cap, veh/h	128	233	312	85	204	248	132	998	105	76	903	89
Arrive On Green	0.20	0.20	0.20	0.16	0.16	0.16	0.07	0.31	0.31	0.04	0.28	0.28
Sat Flow, veh/h	652	1186	1585	541	1302	1585	1781	3246	340	1781	3268	322
Grp Volume(v), veh/h	248	0	248	218	0	90	108	312	319	46	442	451
Grp Sat Flow(s),veh/h/ln	1838	0	1585	1843	0	1585	1781	1777	1809	1781	1777	1812
Q Serve(g_s), s	8.5	0.0	10.1	7.6	0.0	3.4	4.0	10.0	10.0	1.7	16.2	16.2
Cycle Q Clear(g_c), s	8.5	0.0	10.1	7.6	0.0	3.4	4.0	10.0	10.0	1.7	16.2	16.2
Prop In Lane	0.35		1.00	0.29		1.00	1.00		0.19	1.00		0.18
Lane Grp Cap(c), veh/h	362	0	312	288	0	248	132	547	557	76	491	501
V/C Ratio(X)	0.69	0.00	0.79	0.76	0.00	0.36	0.82	0.57	0.57	0.60	0.90	0.90
Avail Cap(c_a), veh/h	490	0	423	492	0	423	132	547	557	132	500	510
HCM Platoon Ratio	1.00	1.00	1.00	1.00	1.00	1.00	1.00	1.00	1.00	1.00	1.00	1.00
Upstream Filter(l)	1.00	0.00	1.00	1.00	0.00	1.00	1.00	1.00	1.00	1.00	1.00	1.00
Uniform Delay (d), s/veh	25.2	0.0	25.8	27.2	0.0	25.5	30.8	19.6	19.6	31.7	23.5	23.5
Incr Delay (d2), s/veh	2.4	0.0	7.3	4.0	0.0	0.9	31.7	1.4	1.4	7.4	19.0	18.7
Initial Q Delay(d3),s/veh	0.0	0.0	0.0	0.0	0.0	0.0	0.0	0.0	0.0	0.0	0.0	0.0
%ile BackOfQ(50%),veh/ln	3.7	0.0	4.2	3.5	0.0	1.3	2.8	4.0	4.1	0.9	8.9	9.0
Unsig. Movement Delay, s/veh												
LnGrp Delay(d),s/veh	27.6	0.0	33.1	31.3	0.0	26.4	62.5	21.0	21.1	39.2	42.5	42.3
LnGrp LOS	C	A	C	C	A	C	E	C	C	D	D	D
Approach Vol, veh/h		496			308			739				939
Approach Delay, s/veh		30.3			29.8			27.1				42.2
Approach LOS		C			C			C				D
Timer - Assigned Phs	1	2		4	5	6		8				
Phs Duration (G+Y+Rc), s	7.9	25.8		18.3	10.0	23.7		15.6				
Change Period (Y+Rc), s	5.0	5.0		5.0	5.0	5.0		5.0				
Max Green Setting (Gmax), s	5.0	19.0		18.0	5.0	19.0		18.0				
Max Q Clear Time (g_c+I1), s	3.7	12.0		12.1	6.0	18.2		9.6				
Green Ext Time (p_c), s	0.0	2.2		1.2	0.0	0.5		1.0				
Intersection Summary												
HCM 6th Ctrl Delay				33.8								
HCM 6th LOS				C								

Intersection

Intersection Delay, s/veh 22.5

Intersection LOS C

Movement	EBL	EBT	EBR	WBL	WBT	WBR	NBL	NBT	NBR	SBL	SBT	SBR
Lane Configurations		↔	↔		↔	↔		↔			↔	
Traffic Vol, veh/h	63	411	124	12	327	80	0	0	1	110	32	66
Future Vol, veh/h	63	411	124	12	327	80	0	0	1	110	32	66
Peak Hour Factor	0.92	0.92	0.92	0.92	0.92	0.92	0.92	0.92	0.92	0.92	0.92	0.92
Heavy Vehicles, %	2	2	2	2	2	2	2	2	2	2	2	2
Mvmt Flow	68	447	135	13	355	87	0	0	1	120	35	72
Number of Lanes	0	1	1	0	1	1	0	1	0	0	1	0

Approach	EB	WB	NB	SB
Opposing Approach	WB	EB	SB	NB
Opposing Lanes	2	2	1	1
Conflicting Approach Left	SB	NB	EB	WB
Conflicting Lanes Left	1	1	2	2
Conflicting Approach Right	NB	SB	WB	EB
Conflicting Lanes Right	1	1	2	2
HCM Control Delay	29.3	17.1	9.8	13.8
HCM LOS	D	C	A	B

Lane	NBLn1	EBLn1	EBLn2	WBLn1	WBLn2	SBLn1
Vol Left, %	0%	13%	0%	4%	0%	53%
Vol Thru, %	0%	87%	0%	96%	0%	15%
Vol Right, %	100%	0%	100%	0%	100%	32%
Sign Control	Stop	Stop	Stop	Stop	Stop	Stop
Traffic Vol by Lane	1	474	124	339	80	208
LT Vol	0	63	0	12	0	110
Through Vol	0	411	0	327	0	32
RT Vol	1	0	124	0	80	66
Lane Flow Rate	1	515	135	368	87	226
Geometry Grp	2	7	7	7	7	2
Degree of Util (X)	0.002	0.857	0.195	0.631	0.131	0.403
Departure Headway (Hd)	6.795	5.987	5.209	6.167	5.437	6.416
Convergence, Y/N	Yes	Yes	Yes	Yes	Yes	Yes
Cap	530	603	687	582	657	558
Service Time	4.795	3.735	2.957	3.924	3.194	4.475
HCM Lane V/C Ratio	0.002	0.854	0.197	0.632	0.132	0.405
HCM Control Delay	9.8	34.5	9.2	19	9	13.8
HCM Lane LOS	A	D	A	C	A	B
HCM 95th-tile Q	0	9.5	0.7	4.4	0.4	1.9

Heritage at Dalia Ranch
8: Imperial Ave & Aten Rd



















Opening Year 2026
Timing Plan: AM PEAK



Movement	EBL	EBT	EBR	WBL	WBT	WBR	NBL	NBT	NBR	SBL	SBT	SBR
Lane Configurations												
Traffic Volume (veh/h)	199	352	65	136	312	147	63	376	70	148	753	404
Future Volume (veh/h)	199	352	65	136	312	147	63	376	70	148	753	404
Initial Q (Qb), veh	0	0	0	0	0	0	0	0	0	0	0	0
Ped-Bike Adj(A_pbT)	1.00		1.00	1.00		1.00	1.00		1.00	1.00		1.00
Parking Bus, Adj	1.00	1.00	1.00	1.00	1.00	1.00	1.00	1.00	1.00	1.00	1.00	1.00
Work Zone On Approach		No			No			No			No	
Adj Sat Flow, veh/h/ln	1870	1870	1870	1870	1870	1870	1870	1870	1870	1870	1870	1870
Adj Flow Rate, veh/h	231	409	76	158	363	171	73	437	81	172	876	470
Peak Hour Factor	0.86	0.86	0.86	0.86	0.86	0.86	0.86	0.86	0.86	0.86	0.86	0.86
Percent Heavy Veh, %	2	2	2	2	2	2	2	2	2	2	2	2
Cap, veh/h	273	729	134	197	473	219	97	860	384	206	1077	480
Arrive On Green	0.15	0.24	0.24	0.11	0.20	0.20	0.05	0.24	0.24	0.12	0.30	0.30
Sat Flow, veh/h	1781	2996	552	1781	2358	1093	1781	3554	1585	1781	3554	1585
Grp Volume(v), veh/h	231	241	244	158	272	262	73	437	81	172	876	470
Grp Sat Flow(s),veh/h/ln	1781	1777	1771	1781	1777	1674	1781	1777	1585	1781	1777	1585
Q Serve(g_s), s	8.7	8.2	8.4	6.0	10.0	10.3	2.8	7.4	2.8	6.6	15.8	20.4
Cycle Q Clear(g_c), s	8.7	8.2	8.4	6.0	10.0	10.3	2.8	7.4	2.8	6.6	15.8	20.4
Prop In Lane	1.00		0.31	1.00		0.65	1.00		1.00	1.00		1.00
Lane Grp Cap(c), veh/h	273	433	431	197	356	336	97	860	384	206	1077	480
V/C Ratio(X)	0.85	0.56	0.57	0.80	0.76	0.78	0.75	0.51	0.21	0.84	0.81	0.98
Avail Cap(c_a), veh/h	283	513	511	231	461	435	129	923	412	206	1077	480
HCM Platoon Ratio	1.00	1.00	1.00	1.00	1.00	1.00	1.00	1.00	1.00	1.00	1.00	1.00
Upstream Filter(l)	1.00	1.00	1.00	1.00	1.00	1.00	1.00	1.00	1.00	1.00	1.00	1.00
Uniform Delay (d), s/veh	28.5	22.9	23.0	30.1	26.2	26.3	32.3	22.7	21.0	30.0	22.3	23.9
Incr Delay (d2), s/veh	19.9	1.1	1.2	15.9	5.5	6.7	15.9	0.5	0.3	24.9	4.9	35.4
Initial Q Delay(d3),s/veh	0.0	0.0	0.0	0.0	0.0	0.0	0.0	0.0	0.0	0.0	0.0	0.0
%ile BackOfQ(50%),veh/ln	5.1	3.4	3.4	3.3	4.6	4.5	1.6	3.0	1.0	4.1	6.9	11.7
Unsig. Movement Delay, s/veh												
LnGrp Delay(d),s/veh	48.5	24.1	24.2	46.0	31.7	33.0	48.3	23.2	21.3	54.9	27.2	59.3
LnGrp LOS	D	C	C	D	C	C	D	C	C	D	C	E
Approach Vol, veh/h		716			692			591			1518	
Approach Delay, s/veh		32.0			35.4			26.0			40.3	
Approach LOS		C			D			C			D	
Timer - Assigned Phs	1	2	3	4	5	6	7	8				
Phs Duration (G+Y+Rc), s	3.0	21.8	12.7	21.9	8.8	26.0	15.6	18.9				
Change Period (Y+Rc), s	5.0	5.0	5.0	5.0	5.0	5.0	5.0	5.0				
Max Green Setting (Gmax), s	3.0	18.0	9.0	20.0	5.0	21.0	11.0	18.0				
Max Q Clear Time (g_c+1), s	3.0	9.4	8.0	10.4	4.8	22.4	10.7	12.3				
Green Ext Time (p_c), s	0.0	2.0	0.0	2.0	0.0	0.0	0.0	1.6				
Intersection Summary												
HCM 6th Ctrl Delay											35.2	
HCM 6th LOS											D	

Heritage at Dalia Ranch
1: SR-86 & Keystone Rd

Opening Year 2026
Timing Plan: PM PEAK

												
Movement	EBL	EBT	EBR	WBL	WBT	WBR	NBL	NBT	NBR	SBL	SBT	SBR
Lane Configurations												
Traffic Volume (veh/h)	43	13	20	34	28	39	11	564	27	55	595	35
Future Volume (veh/h)	43	13	20	34	28	39	11	564	27	55	595	35
Initial Q (Qb), veh	0	0	0	0	0	0	0	0	0	0	0	0
Ped-Bike Adj(A_pbT)	1.00		1.00	1.00		1.00	1.00		1.00	1.00		1.00
Parking Bus, Adj	1.00	1.00	1.00	1.00	1.00	1.00	1.00	1.00	1.00	1.00	1.00	1.00
Work Zone On Approach		No			No			No			No	
Adj Sat Flow, veh/h/ln	1870	1870	1870	1870	1870	1870	1870	1870	1870	1870	1870	1870
Adj Flow Rate, veh/h	48	15	22	38	31	44	12	634	30	62	669	39
Peak Hour Factor	0.89	0.89	0.89	0.89	0.89	0.89	0.89	0.89	0.89	0.89	0.89	0.89
Percent Heavy Veh, %	2	2	2	2	2	2	2	2	2	2	2	2
Cap, veh/h	281	53	55	211	71	83	28	1171	522	118	1351	603
Arrive On Green	0.13	0.13	0.13	0.13	0.13	0.13	0.02	0.33	0.33	0.07	0.38	0.38
Sat Flow, veh/h	795	409	421	456	547	640	1781	3554	1585	1781	3554	1585
Grp Volume(v), veh/h	85	0	0	113	0	0	12	634	30	62	669	39
Grp Sat Flow(s),veh/h/ln	1625	0	0	1643	0	0	1781	1777	1585	1781	1777	1585
Q Serve(g_s), s	0.0	0.0	0.0	0.6	0.0	0.0	0.2	4.6	0.4	1.1	4.6	0.5
Cycle Q Clear(g_c), s	1.4	0.0	0.0	1.9	0.0	0.0	0.2	4.6	0.4	1.1	4.6	0.5
Prop In Lane	0.56		0.26	0.34		0.39	1.00		1.00	1.00		1.00
Lane Grp Cap(c), veh/h	390	0	0	366	0	0	28	1171	522	118	1351	603
V/C Ratio(X)	0.22	0.00	0.00	0.31	0.00	0.00	0.43	0.54	0.06	0.52	0.50	0.06
Avail Cap(c_a), veh/h	1030	0	0	1053	0	0	281	2357	1051	338	2469	1101
HCM Platoon Ratio	1.00	1.00	1.00	1.00	1.00	1.00	1.00	1.00	1.00	1.00	1.00	1.00
Upstream Filter(l)	1.00	0.00	0.00	1.00	0.00	0.00	1.00	1.00	1.00	1.00	1.00	1.00
Uniform Delay (d), s/veh	12.6	0.0	0.0	12.8	0.0	0.0	15.4	8.7	7.3	14.3	7.5	6.2
Incr Delay (d2), s/veh	0.3	0.0	0.0	0.5	0.0	0.0	9.9	0.4	0.0	3.6	0.3	0.0
Initial Q Delay(d3),s/veh	0.0	0.0	0.0	0.0	0.0	0.0	0.0	0.0	0.0	0.0	0.0	0.0
%ile BackOfQ(50%),veh/ln	0.5	0.0	0.0	0.6	0.0	0.0	0.1	1.2	0.1	0.5	1.1	0.1
Unsig. Movement Delay, s/veh												
LnGrp Delay(d),s/veh	12.8	0.0	0.0	13.3	0.0	0.0	25.3	9.1	7.3	17.9	7.8	6.3
LnGrp LOS	B	A	A	B	A	A	C	A	A	B	A	A
Approach Vol, veh/h		85			113			676			770	
Approach Delay, s/veh		12.8			13.3			9.3			8.5	
Approach LOS		B			B			A			A	
Timer - Assigned Phs	1	2		4	5	6		8				
Phs Duration (G+Y+Rc), s	7.1	15.4		9.1	5.5	17.0		9.1				
Change Period (Y+Rc), s	5.0	5.0		5.0	5.0	5.0		5.0				
Max Green Setting (Gmax), s	6.0	21.0		18.0	5.0	22.0		18.0				
Max Q Clear Time (g_c+I1), s	3.1	6.6		3.4	2.2	6.6		3.9				
Green Ext Time (p_c), s	0.0	3.8		0.3	0.0	4.2		0.4				
Intersection Summary												
HCM 6th Ctrl Delay				9.4								
HCM 6th LOS				A								

Intersection												
Int Delay, s/veh	0.3											
Movement	EBL	EBT	EBR	WBL	WBT	WBR	NBL	NBT	NBR	SBL	SBT	SBR
Lane Configurations		↕			↕		↕	↕		↕	↕	
Traffic Vol, veh/h	6	4	0	8	0	5	1	603	8	6	632	18
Future Vol, veh/h	6	4	0	8	0	5	1	603	8	6	632	18
Conflicting Peds, #/hr	0	0	0	0	0	0	0	0	0	0	0	0
Sign Control	Stop	Stop	Stop	Stop	Stop	Stop	Free	Free	Free	Free	Free	Free
RT Channelized	-	-	None	-	-	None	-	-	None	-	-	None
Storage Length	-	-	-	-	-	-	50	-	-	50	-	-
Veh in Median Storage, #	-	1	-	-	1	-	-	0	-	-	0	-
Grade, %	-	0	-	-	0	-	-	0	-	-	0	-
Peak Hour Factor	92	92	92	92	92	92	92	92	92	92	92	92
Heavy Vehicles, %	2	2	2	2	2	2	2	2	2	2	2	2
Mvmt Flow	7	4	0	9	0	5	1	655	9	7	687	20

Major/Minor	Minor2		Minor1		Major1		Major2					
Conflicting Flow All	1041	1377	354	1022	1383	332	707	0	0	664	0	0
Stage 1	711	711	-	662	662	-	-	-	-	-	-	-
Stage 2	330	666	-	360	721	-	-	-	-	-	-	-
Critical Hdwy	7.54	6.54	6.94	7.54	6.54	6.94	4.14	-	-	4.14	-	-
Critical Hdwy Stg 1	6.54	5.54	-	6.54	5.54	-	-	-	-	-	-	-
Critical Hdwy Stg 2	6.54	5.54	-	6.54	5.54	-	-	-	-	-	-	-
Follow-up Hdwy	3.52	4.02	3.32	3.52	4.02	3.32	2.22	-	-	2.22	-	-
Pot Cap-1 Maneuver	184	144	642	190	143	664	887	-	-	921	-	-
Stage 1	390	434	-	417	457	-	-	-	-	-	-	-
Stage 2	657	456	-	631	430	-	-	-	-	-	-	-
Platoon blocked, %								-	-	-	-	-
Mov Cap-1 Maneuver	181	143	642	186	142	664	887	-	-	921	-	-
Mov Cap-2 Maneuver	297	266	-	307	266	-	-	-	-	-	-	-
Stage 1	390	431	-	417	457	-	-	-	-	-	-	-
Stage 2	651	456	-	620	427	-	-	-	-	-	-	-

Approach	EB	WB	NB	SB
HCM Control Delay, s	18.2	14.7	0	0.1
HCM LOS	C	B		

Minor Lane/Major Mvmt	NBL	NBT	NBR	EBLn1WBLn1	SBL	SBT	SBR
Capacity (veh/h)	887	-	-	284	387	921	-
HCM Lane V/C Ratio	0.001	-	-	0.038	0.037	0.007	-
HCM Control Delay (s)	9.1	-	-	18.2	14.7	8.9	-
HCM Lane LOS	A	-	-	C	B	A	-
HCM 95th %tile Q(veh)	0	-	-	0.1	0.1	0	-

Intersection						
Int Delay, s/veh	0.7					
Movement	WBL	WBR	NBT	NBR	SBL	SBT
Lane Configurations	↔		↑↑		↔	↑↑
Traffic Vol, veh/h	20	11	604	31	31	595
Future Vol, veh/h	20	11	604	31	31	595
Conflicting Peds, #/hr	0	0	0	0	0	0
Sign Control	Stop	Stop	Free	Free	Free	Free
RT Channelized	-	None	-	None	-	None
Storage Length	0	-	-	-	140	-
Veh in Median Storage, #	0	-	0	-	-	0
Grade, %	0	-	0	-	-	0
Peak Hour Factor	91	91	91	91	91	91
Heavy Vehicles, %	2	2	2	2	2	2
Mvmt Flow	22	12	664	34	34	654

Major/Minor	Minor1	Major1	Major2		
Conflicting Flow All	1076	349	0	0	698
Stage 1	681	-	-	-	-
Stage 2	395	-	-	-	-
Critical Hdwy	6.84	6.94	-	-	4.14
Critical Hdwy Stg 1	5.84	-	-	-	-
Critical Hdwy Stg 2	5.84	-	-	-	-
Follow-up Hdwy	3.52	3.32	-	-	2.22
Pot Cap-1 Maneuver	214	647	-	-	894
Stage 1	464	-	-	-	-
Stage 2	650	-	-	-	-
Platoon blocked, %			-	-	-
Mov Cap-1 Maneuver	206	647	-	-	894
Mov Cap-2 Maneuver	206	-	-	-	-
Stage 1	464	-	-	-	-
Stage 2	625	-	-	-	-

Approach	WB	NB	SB
HCM Control Delay, s	20.1	0	0.5
HCM LOS	C		

Minor Lane/Major Mvmt	NBT	NBRWBLn1	SBL	SBT
Capacity (veh/h)	-	-	272	894
HCM Lane V/C Ratio	-	-	0.125	0.038
HCM Control Delay (s)	-	-	20.1	9.2
HCM Lane LOS	-	-	C	A
HCM 95th %tile Q(veh)	-	-	0.4	0.1

Heritage at Dalia Ranch
4: Imperial Ave & Neckel Rd

Opening Year 2026
Timing Plan: PM PEAK

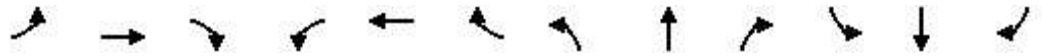

Movement	EBL	EBT	EBR	WBL	WBT	WBR	NBL	NBT	NBR	SBL	SBT	SBR
Lane Configurations		↕			↕		↕	↕		↕	↕	
Traffic Volume (veh/h)	13	27	4	139	20	66	12	579	178	60	517	29
Future Volume (veh/h)	13	27	4	139	20	66	12	579	178	60	517	29
Initial Q (Qb), veh	0	0	0	0	0	0	0	0	0	0	0	0
Ped-Bike Adj(A_pbT)	1.00		1.00	1.00		1.00	1.00		1.00	1.00		1.00
Parking Bus, Adj	1.00	1.00	1.00	1.00	1.00	1.00	1.00	1.00	1.00	1.00	1.00	1.00
Work Zone On Approach		No			No			No			No	
Adj Sat Flow, veh/h/ln	1870	1870	1870	1870	1870	1870	1870	1870	1870	1870	1870	1870
Adj Flow Rate, veh/h	14	29	4	151	22	72	13	629	193	65	562	32
Peak Hour Factor	0.92	0.92	0.92	0.92	0.92	0.92	0.92	0.92	0.92	0.92	0.92	0.92
Percent Heavy Veh, %	2	2	2	2	2	2	2	2	2	2	2	2
Cap, veh/h	26	54	7	198	29	95	29	824	252	106	1197	68
Arrive On Green	0.05	0.05	0.05	0.19	0.19	0.19	0.02	0.31	0.31	0.06	0.35	0.35
Sat Flow, veh/h	541	1120	155	1064	155	507	1781	2679	821	1781	3418	194
Grp Volume(v), veh/h	47	0	0	245	0	0	13	417	405	65	292	302
Grp Sat Flow(s),veh/h/ln	1816	0	0	1726	0	0	1781	1777	1723	1781	1777	1835
Q Serve(g_s), s	1.3	0.0	0.0	6.8	0.0	0.0	0.4	10.7	10.7	1.8	6.4	6.4
Cycle Q Clear(g_c), s	1.3	0.0	0.0	6.8	0.0	0.0	0.4	10.7	10.7	1.8	6.4	6.4
Prop In Lane	0.30		0.09	0.62		0.29	1.00		0.48	1.00		0.11
Lane Grp Cap(c), veh/h	87	0	0	322	0	0	29	546	530	106	622	643
V/C Ratio(X)	0.54	0.00	0.00	0.76	0.00	0.00	0.44	0.76	0.76	0.61	0.47	0.47
Avail Cap(c_a), veh/h	651	0	0	619	0	0	178	673	652	178	673	695
HCM Platoon Ratio	1.00	1.00	1.00	1.00	1.00	1.00	1.00	1.00	1.00	1.00	1.00	1.00
Upstream Filter(l)	1.00	0.00	0.00	1.00	0.00	0.00	1.00	1.00	1.00	1.00	1.00	1.00
Uniform Delay (d), s/veh	23.3	0.0	0.0	19.3	0.0	0.0	24.4	15.7	15.7	23.0	12.7	12.7
Incr Delay (d2), s/veh	5.1	0.0	0.0	3.7	0.0	0.0	10.1	4.1	4.3	5.7	0.5	0.5
Initial Q Delay(d3),s/veh	0.0	0.0	0.0	0.0	0.0	0.0	0.0	0.0	0.0	0.0	0.0	0.0
%ile BackOfQ(50%),veh/ln	0.6	0.0	0.0	2.7	0.0	0.0	0.2	4.3	4.2	0.9	2.2	2.3
Unsig. Movement Delay, s/veh												
LnGrp Delay(d),s/veh	28.5	0.0	0.0	23.1	0.0	0.0	34.5	19.8	20.0	28.7	13.2	13.2
LnGrp LOS	C	A	A	C	A	A	C	B	C	C	B	B
Approach Vol, veh/h		47			245			835			659	
Approach Delay, s/veh		28.5			23.1			20.2			14.7	
Approach LOS		C			C			C			B	
Timer - Assigned Phs	1	2		4	5	6		8				
Phs Duration (G+Y+Rc), s	8.0	20.4		7.4	5.8	22.6		14.4				
Change Period (Y+Rc), s	5.0	5.0		5.0	5.0	5.0		5.0				
Max Green Setting (Gmax), s	5.0	19.0		18.0	5.0	19.0		18.0				
Max Q Clear Time (g_c+I1), s	3.8	12.7		3.3	2.4	8.4		8.8				
Green Ext Time (p_c), s	0.0	2.7		0.1	0.0	2.7		0.9				
Intersection Summary												
HCM 6th Ctrl Delay				18.8								
HCM 6th LOS				B								

Intersection												
Int Delay, s/veh	7.7											
Movement	EBL	EBT	EBR	WBL	WBT	WBR	NBL	NBT	NBR	SBL	SBT	SBR
Lane Configurations		↕			↕			↕			↕	
Traffic Vol, veh/h	2	40	9	24	46	1	5	6	11	0	5	8
Future Vol, veh/h	2	40	9	24	46	1	5	6	11	0	5	8
Conflicting Peds, #/hr	0	0	0	0	0	0	0	0	0	0	0	0
Sign Control	Stop	Stop	Stop	Stop	Stop	Stop	Free	Free	Free	Free	Free	Free
RT Channelized	-	-	None	-	-	None	-	-	None	-	-	None
Storage Length	-	-	-	-	-	-	-	-	-	-	-	-
Veh in Median Storage, #	-	0	-	-	0	-	-	0	-	-	0	-
Grade, %	-	0	-	-	0	-	-	0	-	-	0	-
Peak Hour Factor	79	79	79	79	79	79	79	79	79	79	79	79
Heavy Vehicles, %	2	2	2	2	2	2	2	2	2	2	2	2
Mvmt Flow	3	51	11	30	58	1	6	8	14	0	6	10

Major/Minor	Minor2		Minor1		Major1		Major2					
Conflicting Flow All	68	45	11	69	43	15	16	0	0	22	0	0
Stage 1	11	11	-	27	27	-	-	-	-	-	-	-
Stage 2	57	34	-	42	16	-	-	-	-	-	-	-
Critical Hdwy	7.12	6.52	6.22	7.12	6.52	6.22	4.12	-	-	4.12	-	-
Critical Hdwy Stg 1	6.12	5.52	-	6.12	5.52	-	-	-	-	-	-	-
Critical Hdwy Stg 2	6.12	5.52	-	6.12	5.52	-	-	-	-	-	-	-
Follow-up Hdwy	3.518	4.018	3.318	3.518	4.018	3.318	2.218	-	-	2.218	-	-
Pot Cap-1 Maneuver	925	847	1070	923	849	1065	1602	-	-	1593	-	-
Stage 1	1010	886	-	990	873	-	-	-	-	-	-	-
Stage 2	955	867	-	972	882	-	-	-	-	-	-	-
Platoon blocked, %								-	-	-	-	-
Mov Cap-1 Maneuver	872	844	1070	869	846	1065	1602	-	-	1593	-	-
Mov Cap-2 Maneuver	872	844	-	869	846	-	-	-	-	-	-	-
Stage 1	1006	886	-	986	870	-	-	-	-	-	-	-
Stage 2	886	864	-	907	882	-	-	-	-	-	-	-

Approach	EB		WB		NB		SB	
HCM Control Delay, s	9.4		9.7		1.6		0	
HCM LOS	A		A					

Minor Lane/Major Mvmt	NBL	NBT	NBR	EBLn1	WBLn1	SBL	SBT	SBR
Capacity (veh/h)	1602	-	-	878	856	1593	-	-
HCM Lane V/C Ratio	0.004	-	-	0.074	0.105	-	-	-
HCM Control Delay (s)	7.3	0	-	9.4	9.7	0	-	-
HCM Lane LOS	A	A	-	A	A	A	-	-
HCM 95th %tile Q(veh)	0	-	-	0.2	0.4	0	-	-

Heritage at Dalia Ranch
6: Imperial Ave & Worthington Rd/Barioni Blvd

Opening Year 2026
Timing Plan: PM PEAK

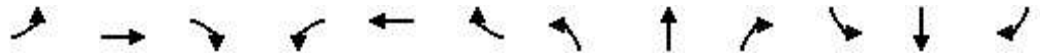

Movement	EBL	EBT	EBR	WBL	WBT	WBR	NBL	NBT	NBR	SBL	SBT	SBR
Lane Configurations		↖	↗		↖	↗	↖	↗	↖	↗	↖	↗
Traffic Volume (veh/h)	65	77	109	57	117	54	117	771	15	28	663	74
Future Volume (veh/h)	65	77	109	57	117	54	117	771	15	28	663	74
Initial Q (Qb), veh	0	0	0	0	0	0	0	0	0	0	0	0
Ped-Bike Adj(A_pbT)	1.00		1.00	1.00		1.00	1.00		1.00	1.00		1.00
Parking Bus, Adj	1.00	1.00	1.00	1.00	1.00	1.00	1.00	1.00	1.00	1.00	1.00	1.00
Work Zone On Approach		No			No			No			No	
Adj Sat Flow, veh/h/ln	1870	1870	1870	1870	1870	1870	1870	1870	1870	1870	1870	1870
Adj Flow Rate, veh/h	71	85	120	63	129	59	129	847	16	31	729	81
Peak Hour Factor	0.91	0.91	0.91	0.91	0.91	0.91	0.91	0.91	0.91	0.91	0.91	0.91
Percent Heavy Veh, %	2	2	2	2	2	2	2	2	2	2	2	2
Cap, veh/h	109	130	207	89	182	233	164	1202	23	61	898	100
Arrive On Green	0.13	0.13	0.13	0.15	0.15	0.15	0.09	0.34	0.34	0.03	0.28	0.28
Sat Flow, veh/h	832	996	1585	604	1236	1585	1781	3568	67	1781	3225	358
Grp Volume(v), veh/h	156	0	120	192	0	59	129	422	441	31	402	408
Grp Sat Flow(s),veh/h/ln	1829	0	1585	1840	0	1585	1781	1777	1858	1781	1777	1806
Q Serve(g_s), s	4.6	0.0	4.1	5.7	0.0	1.9	4.0	11.8	11.8	1.0	12.0	12.0
Cycle Q Clear(g_c), s	4.6	0.0	4.1	5.7	0.0	1.9	4.0	11.8	11.8	1.0	12.0	12.0
Prop In Lane	0.46		1.00	0.33		1.00	1.00		0.04	1.00		0.20
Lane Grp Cap(c), veh/h	239	0	207	270	0	233	164	598	626	61	495	503
V/C Ratio(X)	0.65	0.00	0.58	0.71	0.00	0.25	0.79	0.70	0.70	0.51	0.81	0.81
Avail Cap(c_a), veh/h	578	0	501	582	0	501	188	598	626	156	562	571
HCM Platoon Ratio	1.00	1.00	1.00	1.00	1.00	1.00	1.00	1.00	1.00	1.00	1.00	1.00
Upstream Filter(I)	1.00	0.00	1.00	1.00	0.00	1.00	1.00	1.00	1.00	1.00	1.00	1.00
Uniform Delay (d), s/veh	23.5	0.0	23.3	23.1	0.0	21.5	25.3	16.4	16.4	27.0	19.1	19.1
Incr Delay (d2), s/veh	3.0	0.0	2.5	3.4	0.0	0.6	17.3	3.8	3.6	6.5	7.9	7.8
Initial Q Delay(d3),s/veh	0.0	0.0	0.0	0.0	0.0	0.0	0.0	0.0	0.0	0.0	0.0	0.0
%ile BackOfQ(50%),veh/ln	2.0	0.0	1.5	2.5	0.0	0.7	2.4	4.8	5.0	0.5	5.5	5.6
Unsig. Movement Delay, s/veh												
LnGrp Delay(d),s/veh	26.5	0.0	25.8	26.6	0.0	22.1	42.6	20.2	20.0	33.6	27.0	27.0
LnGrp LOS	C	A	C	C	A	C	D	C	C	C	C	C
Approach Vol, veh/h		276			251			992			841	
Approach Delay, s/veh		26.2			25.5			23.0			27.2	
Approach LOS		C			C			C			C	
Timer - Assigned Phs	1	2		4	5	6		8				
Phs Duration (G+Y+Rc), s	6.9	24.2		12.5	10.3	20.9		13.4				
Change Period (Y+Rc), s	5.0	5.0		5.0	5.0	5.0		5.0				
Max Green Setting (Gmax), s	5.0	19.0		18.0	6.0	18.0		18.0				
Max Q Clear Time (g_c+I1), s	3.0	13.8		6.6	6.0	14.0		7.7				
Green Ext Time (p_c), s	0.0	2.5		0.9	0.0	1.9		0.9				
Intersection Summary												
HCM 6th Ctrl Delay			25.2									
HCM 6th LOS			C									

Intersection

Intersection Delay, s/veh 11.1

Intersection LOS B

Movement	EBL	EBT	EBR	WBL	WBT	WBR	NBL	NBT	NBR	SBL	SBT	SBR
Lane Configurations		↔	↔		↔	↔		↔			↔	
Traffic Vol, veh/h	27	210	34	28	233	35	1	0	0	39	5	25
Future Vol, veh/h	27	210	34	28	233	35	1	0	0	39	5	25
Peak Hour Factor	0.80	0.80	0.80	0.80	0.80	0.80	0.80	0.80	0.80	0.80	0.80	0.80
Heavy Vehicles, %	2	2	2	2	2	2	2	2	2	2	2	2
Mvmt Flow	34	263	43	35	291	44	1	0	0	49	6	31
Number of Lanes	0	1	1	0	1	1	0	1	0	0	1	0

Approach	EB	WB	NB	SB
Opposing Approach	WB	EB	SB	NB
Opposing Lanes	2	2	1	1
Conflicting Approach Left	SB	NB	EB	WB
Conflicting Lanes Left	1	1	2	2
Conflicting Approach Right	NB	SB	WB	EB
Conflicting Lanes Right	1	1	2	2
HCM Control Delay	11.1	11.6	9	9.3
HCM LOS	B	B	A	A

Lane	NBLn1	EBLn1	EBLn2	WBLn1	WBLn2	SBLn1
Vol Left, %	100%	11%	0%	11%	0%	57%
Vol Thru, %	0%	89%	0%	89%	0%	7%
Vol Right, %	0%	0%	100%	0%	100%	36%
Sign Control	Stop	Stop	Stop	Stop	Stop	Stop
Traffic Vol by Lane	1	237	34	261	35	69
LT Vol	1	27	0	28	0	39
Through Vol	0	210	0	233	0	5
RT Vol	0	0	34	0	35	25
Lane Flow Rate	1	296	42	326	44	86
Geometry Grp	2	7	7	7	7	2
Degree of Util (X)	0.002	0.423	0.052	0.464	0.053	0.13
Departure Headway (Hd)	5.921	5.145	4.384	5.115	4.357	5.445
Convergence, Y/N	Yes	Yes	Yes	Yes	Yes	Yes
Cap	600	699	814	705	819	655
Service Time	4	2.886	2.125	2.856	2.097	3.502
HCM Lane V/C Ratio	0.002	0.423	0.052	0.462	0.054	0.131
HCM Control Delay	9	11.6	7.4	12.2	7.3	9.3
HCM Lane LOS	A	B	A	B	A	A
HCM 95th-tile Q	0	2.1	0.2	2.5	0.2	0.4

Heritage at Dalia Ranch
8: Imperial Ave & Aten Rd

Opening Year 2026
Timing Plan: PM PEAK



Movement	EBL	EBT	EBR	WBL	WBT	WBR	NBL	NBT	NBR	SBL	SBT	SBR
Lane Configurations												
Traffic Volume (veh/h)	212	287	71	185	300	128	81	753	155	117	596	227
Future Volume (veh/h)	212	287	71	185	300	128	81	753	155	117	596	227
Initial Q (Qb), veh	0	0	0	0	0	0	0	0	0	0	0	0
Ped-Bike Adj(A_pbT)	1.00		1.00	1.00		1.00	1.00		1.00	1.00		1.00
Parking Bus, Adj	1.00	1.00	1.00	1.00	1.00	1.00	1.00	1.00	1.00	1.00	1.00	1.00
Work Zone On Approach		No		No		No		No		No		No
Adj Sat Flow, veh/h/ln	1870	1870	1870	1870	1870	1870	1870	1870	1870	1870	1870	1870
Adj Flow Rate, veh/h	226	305	76	197	319	136	86	801	165	124	634	241
Peak Hour Factor	0.94	0.94	0.94	0.94	0.94	0.94	0.94	0.94	0.94	0.94	0.94	0.94
Percent Heavy Veh, %	2	2	2	2	2	2	2	2	2	2	2	2
Cap, veh/h	271	562	138	242	445	186	110	960	428	158	1055	470
Arrive On Green	0.15	0.20	0.20	0.14	0.18	0.18	0.06	0.27	0.27	0.09	0.30	0.30
Sat Flow, veh/h	1781	2828	694	1781	2443	1020	1781	3554	1585	1781	3554	1585
Grp Volume(v), veh/h	226	190	191	197	230	225	86	801	165	124	634	241
Grp Sat Flow(s),veh/h/ln	1781	1777	1745	1781	1777	1687	1781	1777	1585	1781	1777	1585
Q Serve(g_s), s	8.0	6.2	6.4	7.0	7.9	8.2	3.1	13.8	5.5	4.4	10.0	8.2
Cycle Q Clear(g_c), s	8.0	6.2	6.4	7.0	7.9	8.2	3.1	13.8	5.5	4.4	10.0	8.2
Prop In Lane	1.00		0.40	1.00		0.61	1.00		1.00	1.00		1.00
Lane Grp Cap(c), veh/h	271	353	347	242	324	307	110	960	428	158	1055	470
V/C Ratio(X)	0.83	0.54	0.55	0.81	0.71	0.73	0.78	0.83	0.39	0.79	0.60	0.51
Avail Cap(c_a), veh/h	301	491	482	301	491	466	164	1036	462	191	1090	486
HCM Platoon Ratio	1.00	1.00	1.00	1.00	1.00	1.00	1.00	1.00	1.00	1.00	1.00	1.00
Upstream Filter(I)	1.00	1.00	1.00	1.00	1.00	1.00	1.00	1.00	1.00	1.00	1.00	1.00
Uniform Delay (d), s/veh	26.8	23.4	23.5	27.4	25.0	25.1	30.1	22.4	19.4	29.1	19.6	19.0
Incr Delay (d2), s/veh	16.6	1.3	1.4	13.0	2.9	3.4	13.0	5.7	0.6	16.1	0.9	0.9
Initial Q Delay(d3),s/veh	0.0	0.0	0.0	0.0	0.0	0.0	0.0	0.0	0.0	0.0	0.0	0.0
%ile BackOfQ(50%),veh/ln	4.5	2.6	2.6	3.7	3.4	3.4	1.7	6.1	2.0	2.5	3.9	2.9
Unsig. Movement Delay, s/veh												
LnGrp Delay(d),s/veh	43.4	24.7	24.9	40.3	27.9	28.5	43.1	28.1	19.9	45.2	20.5	19.9
LnGrp LOS	D	C	C	D	C	C	D	C	B	D	C	B
Approach Vol, veh/h		607			652			1052			999	
Approach Delay, s/veh		31.7			31.9			28.0			23.4	
Approach LOS		C			C			C			C	
Timer - Assigned Phs	1	2	3	4	5	6	7	8				
Phs Duration (G+Y+Rc), s	0.8	22.6	13.9	17.9	9.0	24.3	14.9	16.9				
Change Period (Y+Rc), s	5.0	5.0	5.0	5.0	5.0	5.0	5.0	5.0				
Max Green Setting (Gmax), s	19.0	11.0	18.0	6.0	20.0	11.0	18.0					
Max Q Clear Time (g_c+1/4), s	15.8	9.0	8.4	5.1	12.0	10.0	10.2					
Green Ext Time (p_c), s	0.0	1.8	0.1	1.5	0.0	3.2	0.1	1.7				

Intersection Summary

HCM 6th Ctrl Delay	28.1
HCM 6th LOS	C

Heritage at Dalia Ranch
1: SR-86 & Keystone Rd

Opening Year 2026 + P1-3 Proj
Timing Plan: AM PEAK

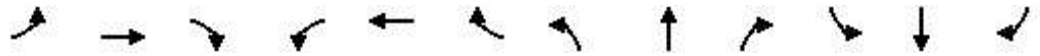

Movement	EBL	EBT	EBR	WBL	WBT	WBR	NBL	NBT	NBR	SBL	SBT	SBR
Lane Configurations		↔			↔		↗	↕	↗	↗	↕	↗
Traffic Volume (veh/h)	34	34	12	19	25	44	19	545	51	47	591	39
Future Volume (veh/h)	34	34	12	19	25	44	19	545	51	47	591	39
Initial Q (Qb), veh	0	0	0	0	0	0	0	0	0	0	0	0
Ped-Bike Adj(A_pbT)	1.00		1.00	1.00		1.00	1.00		1.00	1.00		1.00
Parking Bus, Adj	1.00	1.00	1.00	1.00	1.00	1.00	1.00	1.00	1.00	1.00	1.00	1.00
Work Zone On Approach		No			No			No			No	
Adj Sat Flow, veh/h/ln	1870	1870	1870	1870	1870	1870	1870	1870	1870	1870	1870	1870
Adj Flow Rate, veh/h	38	38	13	21	28	49	21	606	57	52	657	43
Peak Hour Factor	0.90	0.90	0.90	0.90	0.90	0.90	0.90	0.90	0.90	0.90	0.90	0.90
Percent Heavy Veh, %	2	2	2	2	2	2	2	2	2	2	2	2
Cap, veh/h	247	108	32	178	73	108	48	1126	502	104	1239	552
Arrive On Green	0.13	0.13	0.13	0.13	0.13	0.13	0.03	0.32	0.32	0.06	0.35	0.35
Sat Flow, veh/h	592	829	243	264	561	825	1781	3554	1585	1781	3554	1585
Grp Volume(v), veh/h	89	0	0	98	0	0	21	606	57	52	657	43
Grp Sat Flow(s),veh/h/ln	1664	0	0	1650	0	0	1781	1777	1585	1781	1777	1585
Q Serve(g_s), s	0.0	0.0	0.0	0.2	0.0	0.0	0.4	4.3	0.8	0.9	4.5	0.6
Cycle Q Clear(g_c), s	1.4	0.0	0.0	1.6	0.0	0.0	0.4	4.3	0.8	0.9	4.5	0.6
Prop In Lane	0.43		0.15	0.21		0.50	1.00		1.00	1.00		1.00
Lane Grp Cap(c), veh/h	387	0	0	360	0	0	48	1126	502	104	1239	552
V/C Ratio(X)	0.23	0.00	0.00	0.27	0.00	0.00	0.44	0.54	0.11	0.50	0.53	0.08
Avail Cap(c_a), veh/h	1105	0	0	1097	0	0	293	2107	940	293	2107	940
HCM Platoon Ratio	1.00	1.00	1.00	1.00	1.00	1.00	1.00	1.00	1.00	1.00	1.00	1.00
Upstream Filter(l)	1.00	0.00	0.00	1.00	0.00	0.00	1.00	1.00	1.00	1.00	1.00	1.00
Uniform Delay (d), s/veh	12.1	0.0	0.0	12.2	0.0	0.0	14.6	8.5	7.4	13.9	7.9	6.6
Incr Delay (d2), s/veh	0.3	0.0	0.0	0.4	0.0	0.0	6.3	0.4	0.1	3.7	0.4	0.1
Initial Q Delay(d3),s/veh	0.0	0.0	0.0	0.0	0.0	0.0	0.0	0.0	0.0	0.0	0.0	0.0
%ile BackOfQ(50%),veh/ln	0.4	0.0	0.0	0.5	0.0	0.0	0.2	1.1	0.2	0.4	1.1	0.1
Unsig. Movement Delay, s/veh												
LnGrp Delay(d),s/veh	12.4	0.0	0.0	12.6	0.0	0.0	20.8	8.9	7.4	17.5	8.3	6.7
LnGrp LOS	B	A	A	B	A	A	C	A	A	B	A	A
Approach Vol, veh/h		89			98			684			752	
Approach Delay, s/veh		12.4			12.6			9.2			8.8	
Approach LOS		B			B			A			A	
Timer - Assigned Phs	1	2		4	5	6		8				
Phs Duration (G+Y+Rc), s	6.8	14.6		9.0	5.8	15.6		9.0				
Change Period (Y+Rc), s	5.0	5.0		5.0	5.0	5.0		5.0				
Max Green Setting (Gmax), s	5.0	18.0		18.0	5.0	18.0		18.0				
Max Q Clear Time (g_c+I1), s	2.9	6.3		3.4	2.4	6.5		3.6				
Green Ext Time (p_c), s	0.0	3.4		0.3	0.0	3.6		0.4				
Intersection Summary												
HCM 6th Ctrl Delay				9.4								
HCM 6th LOS				A								

Intersection												
Int Delay, s/veh	0.4											
Movement	EBL	EBT	EBR	WBL	WBT	WBR	NBL	NBT	NBR	SBL	SBT	SBR
Lane Configurations		↕			↕		↕	↕		↕	↕	
Traffic Vol, veh/h	20	3	2	1	2	5	0	614	1	1	596	8
Future Vol, veh/h	20	3	2	1	2	5	0	614	1	1	596	8
Conflicting Peds, #/hr	0	0	0	0	0	0	0	0	0	0	0	0
Sign Control	Stop	Stop	Stop	Stop	Stop	Stop	Free	Free	Free	Free	Free	Free
RT Channelized	-	-	None	-	-	None	-	-	None	-	-	None
Storage Length	-	-	-	-	-	-	50	-	-	50	-	-
Veh in Median Storage, #	-	1	-	-	1	-	-	0	-	-	0	-
Grade, %	-	0	-	-	0	-	-	0	-	-	0	-
Peak Hour Factor	94	94	94	94	94	94	94	94	94	94	94	94
Heavy Vehicles, %	2	2	2	2	2	2	2	2	2	2	2	2
Mvmt Flow	21	3	2	1	2	5	0	653	1	1	634	9

Major/Minor	Minor2		Minor1		Major1		Major2					
Conflicting Flow All	969	1295	322	975	1299	327	643	0	0	654	0	0
Stage 1	641	641	-	654	654	-	-	-	-	-	-	-
Stage 2	328	654	-	321	645	-	-	-	-	-	-	-
Critical Hdwy	7.54	6.54	6.94	7.54	6.54	6.94	4.14	-	-	4.14	-	-
Critical Hdwy Stg 1	6.54	5.54	-	6.54	5.54	-	-	-	-	-	-	-
Critical Hdwy Stg 2	6.54	5.54	-	6.54	5.54	-	-	-	-	-	-	-
Follow-up Hdwy	3.52	4.02	3.32	3.52	4.02	3.32	2.22	-	-	2.22	-	-
Pot Cap-1 Maneuver	208	161	674	206	160	669	938	-	-	929	-	-
Stage 1	430	468	-	422	461	-	-	-	-	-	-	-
Stage 2	659	461	-	665	466	-	-	-	-	-	-	-
Platoon blocked, %								-	-	-	-	-
Mov Cap-1 Maneuver	205	161	674	204	160	669	938	-	-	929	-	-
Mov Cap-2 Maneuver	324	285	-	321	285	-	-	-	-	-	-	-
Stage 1	430	468	-	422	461	-	-	-	-	-	-	-
Stage 2	651	461	-	658	466	-	-	-	-	-	-	-

Approach	EB		WB		NB		SB	
HCM Control Delay, s	16.8		13.1		0		0	
HCM LOS	C		B					

Minor Lane/Major Mvmt	NBL	NBT	NBR	EBLn1	WBLn1	SBL	SBT	SBR
Capacity (veh/h)	938	-	-	332	454	929	-	-
HCM Lane V/C Ratio	-	-	-	0.08	0.019	0.001	-	-
HCM Control Delay (s)	0	-	-	16.8	13.1	8.9	-	-
HCM Lane LOS	A	-	-	C	B	A	-	-
HCM 95th %tile Q(veh)	0	-	-	0.3	0.1	0	-	-

Heritage at Dalia Ranch
3: Imperial Ave & Ralph Rd

Opening Year 2026 + P1-3 Proj
Timing Plan: AM PEAK

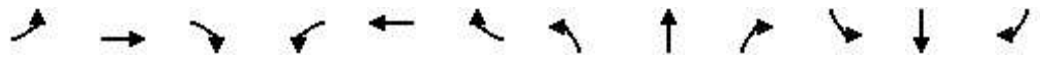

Movement	EBL	EBT	EBR	WBL	WBT	WBR	NBL	NBT	NBR	SBL	SBT	SBR
Lane Configurations	↖	↗		↖	↗		↖	↕	↗	↖	↕	↗
Traffic Volume (veh/h)	60	11	106	61	17	24	134	532	43	20	547	31
Future Volume (veh/h)	60	11	106	61	17	24	134	532	43	20	547	31
Initial Q (Qb), veh	0	0	0	0	0	0	0	0	0	0	0	0
Ped-Bike Adj(A_pbT)	1.00		1.00	1.00		1.00	1.00		1.00	1.00		1.00
Parking Bus, Adj	1.00	1.00	1.00	1.00	1.00	1.00	1.00	1.00	1.00	1.00	1.00	1.00
Work Zone On Approach		No			No			No			No	
Adj Sat Flow, veh/h/ln	1870	1870	1870	1870	1870	1870	1870	1870	1870	1870	1870	1870
Adj Flow Rate, veh/h	65	12	115	67	18	26	146	585	47	22	601	34
Peak Hour Factor	0.92	0.92	0.92	0.91	0.92	0.91	0.92	0.91	0.91	0.91	0.91	0.92
Percent Heavy Veh, %	2	2	2	2	2	2	2	2	2	2	2	2
Cap, veh/h	183	19	178	170	80	115	186	1102	88	47	899	401
Arrive On Green	0.10	0.12	0.12	0.10	0.12	0.12	0.10	0.33	0.33	0.03	0.25	0.25
Sat Flow, veh/h	1781	152	1456	1781	692	999	1781	3332	267	1781	3554	1585
Grp Volume(v), veh/h	65	0	127	67	0	44	146	312	320	22	601	34
Grp Sat Flow(s),veh/h/ln	1781	0	1608	1781	0	1691	1781	1777	1822	1781	1777	1585
Q Serve(g_s), s	1.6	0.0	3.5	1.7	0.0	1.1	3.8	6.7	6.7	0.6	7.2	0.8
Cycle Q Clear(g_c), s	1.6	0.0	3.5	1.7	0.0	1.1	3.8	6.7	6.7	0.6	7.2	0.8
Prop In Lane	1.00		0.91	1.00		0.59	1.00		0.15	1.00		1.00
Lane Grp Cap(c), veh/h	183	0	197	170	0	195	186	588	603	47	899	401
V/C Ratio(X)	0.36	0.00	0.65	0.39	0.00	0.23	0.78	0.53	0.53	0.47	0.67	0.08
Avail Cap(c_a), veh/h	681	0	615	681	0	646	227	717	735	189	1359	606
HCM Platoon Ratio	1.00	1.00	1.00	1.00	1.00	1.00	1.00	1.00	1.00	1.00	1.00	1.00
Upstream Filter(l)	1.00	0.00	1.00	1.00	0.00	1.00	1.00	1.00	1.00	1.00	1.00	1.00
Uniform Delay (d), s/veh	19.7	0.0	19.7	20.0	0.0	18.9	20.6	12.8	12.8	22.6	15.8	13.4
Incr Delay (d2), s/veh	1.2	0.0	3.5	1.5	0.0	0.6	13.6	0.7	0.7	6.9	0.9	0.1
Initial Q Delay(d3),s/veh	0.0	0.0	0.0	0.0	0.0	0.0	0.0	0.0	0.0	0.0	0.0	0.0
%ile BackOfQ(50%),veh/ln	0.7	0.0	1.4	0.7	0.0	0.4	2.1	2.3	2.4	0.3	2.6	0.2
Unsig. Movement Delay, s/veh												
LnGrp Delay(d),s/veh	20.8	0.0	23.2	21.5	0.0	19.5	34.2	13.5	13.5	29.5	16.7	13.5
LnGrp LOS	C	A	C	C	A	B	C	B	B	C	B	B
Approach Vol, veh/h		192			111			778			657	
Approach Delay, s/veh		22.4			20.7			17.4			17.0	
Approach LOS		C			C			B			B	
Timer - Assigned Phs	1	2	3	4	5	6	7	8				
Phs Duration (G+Y+Rc), s	6.3	20.6	9.5	10.8	9.9	16.9	9.8	10.4				
Change Period (Y+Rc), s	5.0	5.0	5.0	5.0	5.0	5.0	5.0	5.0				
Max Green Setting (Gmax), s	5.0	19.0	18.0	18.0	6.0	18.0	18.0	18.0				
Max Q Clear Time (g_c+I1), s	2.6	8.7	3.7	5.5	5.8	9.2	3.6	3.1				
Green Ext Time (p_c), s	0.0	2.8	0.1	0.5	0.0	2.7	0.1	0.1				
Intersection Summary												
HCM 6th Ctrl Delay			18.0									
HCM 6th LOS			B									

Heritage at Dalia Ranch
4: Imperial Ave & Neckel Rd

Opening Year 2026 + P1-3 Proj
Timing Plan: AM PEAK



Movement	EBL	EBT	EBR	WBL	WBT	WBR	NBL	NBT	NBR	SBL	SBT	SBR
Lane Configurations		↕			↕		↕	↕		↕	↕	
Traffic Volume (veh/h)	35	45	65	228	66	102	27	578	95	35	671	32
Future Volume (veh/h)	35	45	65	228	66	102	27	578	95	35	671	32
Initial Q (Qb), veh	0	0	0	0	0	0	0	0	0	0	0	0
Ped-Bike Adj(A_pbT)	1.00		1.00	1.00		1.00	1.00		1.00	1.00		1.00
Parking Bus, Adj	1.00	1.00	1.00	1.00	1.00	1.00	1.00	1.00	1.00	1.00	1.00	1.00
Work Zone On Approach		No			No			No			No	
Adj Sat Flow, veh/h/ln	1870	1870	1870	1870	1870	1870	1870	1870	1870	1870	1870	1870
Adj Flow Rate, veh/h	38	49	71	251	73	112	30	635	104	38	737	35
Peak Hour Factor	0.91	0.91	0.91	0.91	0.91	0.91	0.91	0.91	0.91	0.91	0.91	0.91
Percent Heavy Veh, %	2	2	2	2	2	2	2	2	2	2	2	2
Cap, veh/h	50	64	93	275	80	123	57	780	128	68	902	43
Arrive On Green	0.12	0.12	0.12	0.28	0.28	0.28	0.03	0.26	0.26	0.04	0.26	0.26
Sat Flow, veh/h	412	531	769	1002	291	447	1781	3057	500	1781	3454	164
Grp Volume(v), veh/h	158	0	0	436	0	0	30	369	370	38	379	393
Grp Sat Flow(s),veh/h/ln	1711	0	0	1740	0	0	1781	1777	1780	1781	1777	1841
Q Serve(g_s), s	5.8	0.0	0.0	15.6	0.0	0.0	1.1	12.6	12.6	1.4	12.9	12.9
Cycle Q Clear(g_c), s	5.8	0.0	0.0	15.6	0.0	0.0	1.1	12.6	12.6	1.4	12.9	12.9
Prop In Lane	0.24		0.45	0.58		0.26	1.00		0.28	1.00		0.09
Lane Grp Cap(c), veh/h	208	0	0	479	0	0	57	453	454	68	464	481
V/C Ratio(X)	0.76	0.00	0.00	0.91	0.00	0.00	0.52	0.81	0.82	0.56	0.82	0.82
Avail Cap(c_a), veh/h	478	0	0	486	0	0	138	523	525	138	523	542
HCM Platoon Ratio	1.00	1.00	1.00	1.00	1.00	1.00	1.00	1.00	1.00	1.00	1.00	1.00
Upstream Filter(l)	1.00	0.00	0.00	1.00	0.00	0.00	1.00	1.00	1.00	1.00	1.00	1.00
Uniform Delay (d), s/veh	27.4	0.0	0.0	22.6	0.0	0.0	30.7	22.6	22.6	30.5	22.4	22.4
Incr Delay (d2), s/veh	5.6	0.0	0.0	21.2	0.0	0.0	7.2	8.4	8.6	6.9	8.9	8.6
Initial Q Delay(d3),s/veh	0.0	0.0	0.0	0.0	0.0	0.0	0.0	0.0	0.0	0.0	0.0	0.0
%ile BackOfQ(50%),veh/ln	2.6	0.0	0.0	8.7	0.0	0.0	0.6	5.9	6.0	0.7	6.1	6.3
Unsig. Movement Delay, s/veh												
LnGrp Delay(d),s/veh	33.1	0.0	0.0	43.8	0.0	0.0	37.9	31.0	31.1	37.4	31.2	31.0
LnGrp LOS	C	A	A	D	A	A	D	C	C	D	C	C
Approach Vol, veh/h		158			436			769			810	
Approach Delay, s/veh		33.1			43.8			31.3			31.4	
Approach LOS		C			D			C			C	
Timer - Assigned Phs	1	2		4	5	6		8				
Phs Duration (G+Y+Rc), s	7.5	21.5		12.8	7.1	21.8		22.7				
Change Period (Y+Rc), s	5.0	5.0		5.0	5.0	5.0		5.0				
Max Green Setting (Gmax), s	5.0	19.0		18.0	5.0	19.0		18.0				
Max Q Clear Time (g_c+1), s	13.4	14.6		7.8	3.1	14.9		17.6				
Green Ext Time (p_c), s	0.0	1.8		0.6	0.0	1.8		0.1				

Intersection Summary

HCM 6th Ctrl Delay				34.0								
HCM 6th LOS				C								

Intersection												
Int Delay, s/veh	9.1											
Movement	EBL	EBT	EBR	WBL	WBT	WBR	NBL	NBT	NBR	SBL	SBT	SBR
Lane Configurations		↕			↕			↕			↕	
Traffic Vol, veh/h	4	43	24	69	46	67	8	28	47	77	25	1
Future Vol, veh/h	4	43	24	69	46	67	8	28	47	77	25	1
Conflicting Peds, #/hr	0	0	0	0	0	0	0	0	0	0	0	0
Sign Control	Stop	Stop	Stop	Stop	Stop	Stop	Free	Free	Free	Free	Free	Free
RT Channelized	-	-	None	-	-	None	-	-	None	-	-	None
Storage Length	-	-	-	-	-	-	-	-	-	-	-	-
Veh in Median Storage, #	-	0	-	-	0	-	-	0	-	-	0	-
Grade, %	-	0	-	-	0	-	-	0	-	-	0	-
Peak Hour Factor	79	79	79	79	79	79	79	79	79	79	79	79
Heavy Vehicles, %	2	2	2	2	2	2	2	2	2	2	2	2
Mvmt Flow	5	54	30	87	58	85	10	35	59	97	32	1

Major/Minor	Minor2		Minor1		Major1			Major2				
Conflicting Flow All	383	341	33	354	312	65	33	0	0	94	0	0
Stage 1	227	227	-	85	85	-	-	-	-	-	-	-
Stage 2	156	114	-	269	227	-	-	-	-	-	-	-
Critical Hdwy	7.12	6.52	6.22	7.12	6.52	6.22	4.12	-	-	4.12	-	-
Critical Hdwy Stg 1	6.12	5.52	-	6.12	5.52	-	-	-	-	-	-	-
Critical Hdwy Stg 2	6.12	5.52	-	6.12	5.52	-	-	-	-	-	-	-
Follow-up Hdwy	3.518	4.018	3.318	3.518	4.018	3.318	2.218	-	-	2.218	-	-
Pot Cap-1 Maneuver	575	581	1041	601	603	999	1579	-	-	1500	-	-
Stage 1	776	716	-	923	824	-	-	-	-	-	-	-
Stage 2	846	801	-	737	716	-	-	-	-	-	-	-
Platoon blocked, %								-	-	-	-	-
Mov Cap-1 Maneuver	458	539	1041	509	559	999	1579	-	-	1500	-	-
Mov Cap-2 Maneuver	458	539	-	509	559	-	-	-	-	-	-	-
Stage 1	771	669	-	917	818	-	-	-	-	-	-	-
Stage 2	714	795	-	614	669	-	-	-	-	-	-	-

Approach	EB		WB		NB		SB	
HCM Control Delay, s	11.6		13.8		0.7		5.7	
HCM LOS	B		B					

Minor Lane/Major Mvmt	NBL	NBT	NBR	EBLn1	WBLn1	SBL	SBT	SBR
Capacity (veh/h)	1579	-	-	636	639	1500	-	-
HCM Lane V/C Ratio	0.006	-	-	0.141	0.361	0.065	-	-
HCM Control Delay (s)	7.3	0	-	11.6	13.8	7.6	0	-
HCM Lane LOS	A	A	-	B	B	A	A	-
HCM 95th %tile Q(veh)	0	-	-	0.5	1.6	0.2	-	-

Heritage at Dalia Ranch
6: Imperial Ave & Worthington Rd/Barioni Blvd

Opening Year 2026 + P1-3 Proj
Timing Plan: AM PEAK

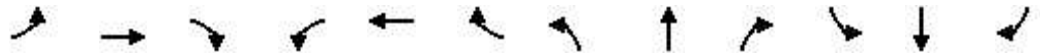

Movement	EBL	EBT	EBR	WBL	WBT	WBR	NBL	NBT	NBR	SBL	SBT	SBR
Lane Configurations		↕	↗		↕	↗	↖	↕↗		↖	↕↗	
Traffic Volume (veh/h)	78	142	221	57	137	104	96	618	53	72	883	71
Future Volume (veh/h)	78	142	221	57	137	104	96	618	53	72	883	71
Initial Q (Qb), veh	0	0	0	0	0	0	0	0	0	0	0	0
Ped-Bike Adj(A_pbT)	1.00		1.00	1.00		1.00	1.00		1.00	1.00		1.00
Parking Bus, Adj	1.00	1.00	1.00	1.00	1.00	1.00	1.00	1.00	1.00	1.00	1.00	1.00
Work Zone On Approach		No			No			No			No	
Adj Sat Flow, veh/h/ln	1870	1870	1870	1870	1870	1870	1870	1870	1870	1870	1870	1870
Adj Flow Rate, veh/h	88	160	248	64	154	117	108	694	60	81	992	80
Peak Hour Factor	0.89	0.89	0.89	0.89	0.89	0.89	0.89	0.89	0.89	0.89	0.89	0.89
Percent Heavy Veh, %	2	2	2	2	2	2	2	2	2	2	2	2
Cap, veh/h	128	233	311	85	205	249	131	974	84	104	930	75
Arrive On Green	0.20	0.20	0.20	0.16	0.16	0.16	0.07	0.29	0.29	0.06	0.28	0.28
Sat Flow, veh/h	652	1186	1585	541	1302	1585	1781	3310	286	1781	3330	269
Grp Volume(v), veh/h	248	0	248	218	0	117	108	372	382	81	529	543
Grp Sat Flow(s),veh/h/ln	1838	0	1585	1843	0	1585	1781	1777	1819	1781	1777	1822
Q Serve(g_s), s	8.5	0.0	10.1	7.7	0.0	4.6	4.1	12.7	12.8	3.1	19.0	19.0
Cycle Q Clear(g_c), s	8.5	0.0	10.1	7.7	0.0	4.6	4.1	12.7	12.8	3.1	19.0	19.0
Prop In Lane	0.35		1.00	0.29		1.00	1.00		0.16	1.00		0.15
Lane Grp Cap(c), veh/h	361	0	311	290	0	249	131	523	535	104	496	509
V/C Ratio(X)	0.69	0.00	0.80	0.75	0.00	0.47	0.83	0.71	0.71	0.78	1.07	1.07
Avail Cap(c_a), veh/h	486	0	419	487	0	419	131	523	535	131	496	509
HCM Platoon Ratio	1.00	1.00	1.00	1.00	1.00	1.00	1.00	1.00	1.00	1.00	1.00	1.00
Upstream Filter(l)	1.00	0.00	1.00	1.00	0.00	1.00	1.00	1.00	1.00	1.00	1.00	1.00
Uniform Delay (d), s/veh	25.4	0.0	26.1	27.4	0.0	26.1	31.1	21.4	21.4	31.6	24.5	24.5
Incr Delay (d2), s/veh	2.5	0.0	7.5	3.9	0.0	1.4	33.2	4.5	4.4	20.7	59.4	59.0
Initial Q Delay(d3),s/veh	0.0	0.0	0.0	0.0	0.0	0.0	0.0	0.0	0.0	0.0	0.0	0.0
%ile BackOfQ(50%),veh/ln	3.8	0.0	4.3	3.5	0.0	1.7	2.9	5.6	5.7	1.9	15.6	15.9
Unsig. Movement Delay, s/veh												
LnGrp Delay(d),s/veh	27.9	0.0	33.6	31.3	0.0	27.5	64.3	25.9	25.9	52.3	84.0	83.6
LnGrp LOS	C	A	C	C	A	C	E	C	C	D	F	F
Approach Vol, veh/h		496			335			862			1153	
Approach Delay, s/veh		30.8			30.0			30.7			81.6	
Approach LOS		C			C			C			F	
Timer - Assigned Phs	1	2		4	5	6		8				
Phs Duration (G+Y+Rc), s	9.0	25.0		18.4	10.0	24.0		15.7				
Change Period (Y+Rc), s	5.0	5.0		5.0	5.0	5.0		5.0				
Max Green Setting (Gmax), s	5.0	19.0		18.0	5.0	19.0		18.0				
Max Q Clear Time (g_c+I1), s	5.1	14.8		12.1	6.1	21.0		9.7				
Green Ext Time (p_c), s	0.0	1.8		1.2	0.0	0.0		1.0				
Intersection Summary												
HCM 6th Ctrl Delay				51.2								
HCM 6th LOS				D								

Intersection

Intersection Delay, s/veh27.7

Intersection LOS D

Movement	EBL	EBT	EBR	WBL	WBT	WBR	NBL	NBT	NBR	SBL	SBT	SBR
Lane Configurations		↔	↔		↔	↔		↔			↔	
Traffic Vol, veh/h	87	411	124	12	327	80	0	0	1	110	32	97
Future Vol, veh/h	87	411	124	12	327	80	0	0	1	110	32	97
Peak Hour Factor	0.92	0.92	0.92	0.92	0.92	0.92	0.92	0.92	0.92	0.92	0.92	0.92
Heavy Vehicles, %	2	2	2	2	2	2	2	2	2	2	2	2
Mvmt Flow	95	447	135	13	355	87	0	0	1	120	35	105
Number of Lanes	0	1	1	0	1	1	0	1	0	0	1	0

Approach	EB	WB	NB	SB
Opposing Approach	WB	EB	SB	NB
Opposing Lanes	2	2	1	1
Conflicting Approach Left	SB	NB	EB	WB
Conflicting Lanes Left	1	1	2	2
Conflicting Approach Right	NB	SB	WB	EB
Conflicting Lanes Right	1	1	2	2
HCM Control Delay	38.8	18.3	10.1	15.1
HCM LOS	E	C	B	C

Lane	NBLn1	EBLn1	EBLn2	WBLn1	WBLn2	SBLn1
Vol Left, %	0%	17%	0%	4%	0%	46%
Vol Thru, %	0%	83%	0%	96%	0%	13%
Vol Right, %	100%	0%	100%	0%	100%	41%
Sign Control	Stop	Stop	Stop	Stop	Stop	Stop
Traffic Vol by Lane	1	498	124	339	80	239
LT Vol	0	87	0	12	0	110
Through Vol	0	411	0	327	0	32
RT Vol	1	0	124	0	80	97
Lane Flow Rate	1	541	135	368	87	260
Geometry Grp	2	7	7	7	7	2
Degree of Util (X)	0.002	0.927	0.201	0.652	0.136	0.465
Departure Headway (Hd)	7.078	6.168	5.368	6.371	5.64	6.449
Convergence, Y/N	Yes	Yes	Yes	Yes	Yes	Yes
Cap	509	585	666	564	632	556
Service Time	5.078	3.929	3.128	4.142	3.41	4.518
HCM Lane V/C Ratio	0.002	0.925	0.203	0.652	0.138	0.468
HCM Control Delay	10.1	46.1	9.5	20.4	9.3	15.1
HCM Lane LOS	B	E	A	C	A	C
HCM 95th-tile Q	0	11.8	0.7	4.7	0.5	2.4

Heritage at Dalia Ranch
8: Imperial Ave & Aten Rd

Opening Year 2026 + P1-3 Proj
Timing Plan: AM PEAK



Movement	EBL	EBT	EBR	WBL	WBT	WBR	NBL	NBT	NBR	SBL	SBT	SBR
Lane Configurations												
Traffic Volume (veh/h)	223	352	65	136	312	171	63	437	70	179	852	435
Future Volume (veh/h)	223	352	65	136	312	171	63	437	70	179	852	435
Initial Q (Qb), veh	0	0	0	0	0	0	0	0	0	0	0	0
Ped-Bike Adj(A_pbT)	1.00		1.00	1.00		1.00	1.00		1.00	1.00		1.00
Parking Bus, Adj	1.00	1.00	1.00	1.00	1.00	1.00	1.00	1.00	1.00	1.00	1.00	1.00
Work Zone On Approach		No		No		No		No		No		No
Adj Sat Flow, veh/h/ln	1870	1870	1870	1870	1870	1870	1870	1870	1870	1870	1870	1870
Adj Flow Rate, veh/h	259	409	76	158	363	199	73	508	81	208	991	506
Peak Hour Factor	0.86	0.86	0.86	0.86	0.86	0.86	0.86	0.86	0.86	0.86	0.86	0.86
Percent Heavy Veh, %	2	2	2	2	2	2	2	2	2	2	2	2
Cap, veh/h	298	774	143	197	449	242	94	815	363	247	1121	500
Arrive On Green	0.17	0.26	0.26	0.11	0.20	0.20	0.05	0.23	0.23	0.14	0.32	0.32
Sat Flow, veh/h	1781	2996	552	1781	2229	1202	1781	3554	1585	1781	3554	1585
Grp Volume(v), veh/h	259	241	244	158	288	274	73	508	81	208	991	506
Grp Sat Flow(s),veh/h/ln	1781	1777	1771	1781	1777	1654	1781	1777	1585	1781	1777	1585
Q Serve(g_s), s	10.8	8.9	9.0	6.6	11.8	12.1	3.1	9.8	3.2	8.7	20.1	24.0
Cycle Q Clear(g_c), s	10.8	8.9	9.0	6.6	11.8	12.1	3.1	9.8	3.2	8.7	20.1	24.0
Prop In Lane	1.00		0.31	1.00		0.73	1.00		1.00	1.00		1.00
Lane Grp Cap(c), veh/h	298	459	457	197	358	333	94	815	363	247	1121	500
V/C Ratio(X)	0.87	0.53	0.53	0.80	0.80	0.82	0.78	0.62	0.22	0.84	0.88	1.01
Avail Cap(c_a), veh/h	304	459	457	304	420	391	117	841	375	258	1121	500
HCM Platoon Ratio	1.00	1.00	1.00	1.00	1.00	1.00	1.00	1.00	1.00	1.00	1.00	1.00
Upstream Filter(l)	1.00	1.00	1.00	1.00	1.00	1.00	1.00	1.00	1.00	1.00	1.00	1.00
Uniform Delay (d), s/veh	30.8	24.2	24.3	33.0	28.9	29.1	35.6	26.4	23.8	31.9	24.7	26.0
Incr Delay (d2), s/veh	22.2	1.1	1.2	8.3	9.5	11.5	22.8	1.4	0.3	20.9	8.6	43.2
Initial Q Delay(d3),s/veh	0.0	0.0	0.0	0.0	0.0	0.0	0.0	0.0	0.0	0.0	0.0	0.0
%ile BackOfQ(50%),veh/ln	6.3	3.7	3.8	3.2	5.8	5.7	1.9	4.1	1.2	5.0	9.3	14.5
Unsig. Movement Delay, s/veh												
LnGrp Delay(d),s/veh	53.0	25.3	25.5	41.3	38.4	40.5	58.4	27.7	24.1	52.9	33.3	69.3
LnGrp LOS	D	C	C	D	D	D	E	C	C	D	C	F
Approach Vol, veh/h		744			720			662			1705	
Approach Delay, s/veh		35.0			39.8			30.7			46.4	
Approach LOS		D			D			C			D	
Timer - Assigned Phs	1	2	3	4	5	6	7	8				
Phs Duration (G+Y+Rc), s	5.6	22.4	13.4	24.7	9.0	29.0	17.7	20.3				
Change Period (Y+Rc), s	5.0	5.0	5.0	5.0	5.0	5.0	5.0	5.0				
Max Green Setting (Gmax), s	18.0	18.0	13.0	18.0	5.0	24.0	13.0	18.0				
Max Q Clear Time (g_c+110), s	11.8	8.6	11.0	5.1	26.0	12.8	14.1					
Green Ext Time (p_c), s	0.0	1.9	0.2	1.7	0.0	0.0	0.0	1.3				
Intersection Summary												
HCM 6th Ctrl Delay											40.2	
HCM 6th LOS											D	

Intersection						
Int Delay, s/veh	2.2					
Movement	EBL	EBT	WBT	WBR	SBL	SBR
Lane Configurations	↖	↑	↗		↖	↗
Traffic Vol, veh/h	3	93	107	18	52	7
Future Vol, veh/h	3	93	107	18	52	7
Conflicting Peds, #/hr	0	0	0	0	0	0
Sign Control	Free	Free	Free	Free	Stop	Stop
RT Channelized	-	None	-	None	-	None
Storage Length	50	-	-	-	0	0
Veh in Median Storage, #	-	0	0	-	0	-
Grade, %	-	0	0	-	0	-
Peak Hour Factor	92	92	92	92	92	92
Heavy Vehicles, %	2	2	2	2	2	2
Mvmt Flow	3	101	116	20	57	8

Major/Minor	Major1	Major2	Minor2		
Conflicting Flow All	136	0	-	0	233
Stage 1	-	-	-	-	126
Stage 2	-	-	-	-	107
Critical Hdwy	4.12	-	-	-	6.42
Critical Hdwy Stg 1	-	-	-	-	5.42
Critical Hdwy Stg 2	-	-	-	-	5.42
Follow-up Hdwy	2.218	-	-	-	3.518
Pot Cap-1 Maneuver	1448	-	-	-	755
Stage 1	-	-	-	-	900
Stage 2	-	-	-	-	917
Platoon blocked, %		-	-	-	
Mov Cap-1 Maneuver	1448	-	-	-	753
Mov Cap-2 Maneuver	-	-	-	-	753
Stage 1	-	-	-	-	898
Stage 2	-	-	-	-	917

Approach	EB	WB	SB
HCM Control Delay, s	0.2	0	10
HCM LOS			B

Minor Lane/Major Mvmt	EBL	EBT	WBT	WBR	SBLn1	SBLn2
Capacity (veh/h)	1448	-	-	-	753	924
HCM Lane V/C Ratio	0.002	-	-	-	0.075	0.008
HCM Control Delay (s)	7.5	-	-	-	10.2	8.9
HCM Lane LOS	A	-	-	-	B	A
HCM 95th %tile Q(veh)	0	-	-	-	0.2	0

Intersection						
Int Delay, s/veh	0.7					
Movement	WBL	WBR	NBT	NBR	SBL	SBT
Lane Configurations						
Traffic Vol, veh/h	7	0	43	3	0	32
Future Vol, veh/h	7	0	43	3	0	32
Conflicting Peds, #/hr	0	0	0	0	0	0
Sign Control	Stop	Stop	Free	Free	Free	Free
RT Channelized	-	None	-	None	-	None
Storage Length	0	0	-	-	50	-
Veh in Median Storage, #	0	-	0	-	-	0
Grade, %	0	-	0	-	-	0
Peak Hour Factor	92	92	92	92	92	92
Heavy Vehicles, %	2	2	2	2	2	2
Mvmt Flow	8	0	47	3	0	35

Major/Minor	Minor1	Major1	Major2		
Conflicting Flow All	84	49	0	0	50
Stage 1	49	-	-	-	-
Stage 2	35	-	-	-	-
Critical Hdwy	6.42	6.22	-	-	4.12
Critical Hdwy Stg 1	5.42	-	-	-	-
Critical Hdwy Stg 2	5.42	-	-	-	-
Follow-up Hdwy	3.518	3.318	-	-	2.218
Pot Cap-1 Maneuver	918	1020	-	-	1557
Stage 1	973	-	-	-	-
Stage 2	987	-	-	-	-
Platoon blocked, %					
Mov Cap-1 Maneuver	918	1020	-	-	1557
Mov Cap-2 Maneuver	918	-	-	-	-
Stage 1	973	-	-	-	-
Stage 2	987	-	-	-	-

Approach	WB	NB	SB
HCM Control Delay, s	9	0	0
HCM LOS	A		

Minor Lane/Major Mvmt	NBT	NBRWBLn1	WBLn2	SBL	SBT
Capacity (veh/h)	-	-	918	-	1557
HCM Lane V/C Ratio	-	-	0.008	-	-
HCM Control Delay (s)	-	-	9	0	0
HCM Lane LOS	-	-	A	A	A
HCM 95th %tile Q(veh)	-	-	0	-	0

Intersection						
Int Delay, s/veh	5.4					
Movement	EBT	EBR	WBL	WBT	NBL	NBR
Lane Configurations	↔		↔	↑	↔	↔
Traffic Vol, veh/h	32	0	28	28	0	81
Future Vol, veh/h	32	0	28	28	0	81
Conflicting Peds, #/hr	0	0	0	0	0	0
Sign Control	Free	Free	Free	Free	Stop	Stop
RT Channelized	-	None	-	None	-	None
Storage Length	-	-	50	-	0	0
Veh in Median Storage, #	0	-	-	0	0	-
Grade, %	0	-	-	0	0	-
Peak Hour Factor	92	92	92	92	92	92
Heavy Vehicles, %	2	2	2	2	2	2
Mvmt Flow	35	0	30	30	0	88

Major/Minor	Major1	Major2	Minor1		
Conflicting Flow All	0	0	35	0	125 35
Stage 1	-	-	-	-	35 -
Stage 2	-	-	-	-	90 -
Critical Hdwy	-	-	4.12	-	6.42 6.22
Critical Hdwy Stg 1	-	-	-	-	5.42 -
Critical Hdwy Stg 2	-	-	-	-	5.42 -
Follow-up Hdwy	-	-	2.218	-	3.518 3.318
Pot Cap-1 Maneuver	-	-	1576	-	870 1038
Stage 1	-	-	-	-	987 -
Stage 2	-	-	-	-	934 -
Platoon blocked, %	-	-	-	-	-
Mov Cap-1 Maneuver	-	-	1576	-	853 1038
Mov Cap-2 Maneuver	-	-	-	-	853 -
Stage 1	-	-	-	-	987 -
Stage 2	-	-	-	-	916 -

Approach	EB	WB	NB
HCM Control Delay, s	0	3.7	8.8
HCM LOS			A

Minor Lane/Major Mvmt	NBLn1	NBLn2	EBT	EBR	WBL	WBT
Capacity (veh/h)	-	1038	-	-	1576	-
HCM Lane V/C Ratio	-	0.085	-	-	0.019	-
HCM Control Delay (s)	0	8.8	-	-	7.3	-
HCM Lane LOS	A	A	-	-	A	-
HCM 95th %tile Q(veh)	-	0.3	-	-	0.1	-

Intersection						
Int Delay, s/veh	2.4					
Movement	EBT	EBR	WBL	WBT	NBL	NBR
Lane Configurations						
Traffic Vol, veh/h	111	2	16	51	5	42
Future Vol, veh/h	111	2	16	51	5	42
Conflicting Peds, #/hr	0	0	0	0	0	0
Sign Control	Free	Free	Free	Free	Stop	Stop
RT Channelized	-	None	-	None	-	None
Storage Length	-	-	50	-	0	0
Veh in Median Storage, #	0	-	-	0	0	-
Grade, %	0	-	-	0	0	-
Peak Hour Factor	92	92	92	92	92	92
Heavy Vehicles, %	2	2	2	2	2	2
Mvmt Flow	121	2	17	55	5	46

Major/Minor	Major1	Major2	Minor1		
Conflicting Flow All	0	0	123	0	211
Stage 1	-	-	-	-	122
Stage 2	-	-	-	-	89
Critical Hdwy	-	-	4.12	-	6.42
Critical Hdwy Stg 1	-	-	-	-	5.42
Critical Hdwy Stg 2	-	-	-	-	5.42
Follow-up Hdwy	-	-	2.218	-	3.518
Pot Cap-1 Maneuver	-	-	1464	-	777
Stage 1	-	-	-	-	903
Stage 2	-	-	-	-	934
Platoon blocked, %	-	-	-	-	-
Mov Cap-1 Maneuver	-	-	1464	-	768
Mov Cap-2 Maneuver	-	-	-	-	768
Stage 1	-	-	-	-	903
Stage 2	-	-	-	-	923

Approach	EB	WB	NB
HCM Control Delay, s	0	1.8	9.2
HCM LOS			A

Minor Lane/Major Mvmt	NBLn1	NBLn2	EBT	EBR	WBL	WBT
Capacity (veh/h)	768	929	-	-	1464	-
HCM Lane V/C Ratio	0.007	0.049	-	-	0.012	-
HCM Control Delay (s)	9.7	9.1	-	-	7.5	-
HCM Lane LOS	A	A	-	-	A	-
HCM 95th %tile Q(veh)	0	0.2	-	-	0	-

Intersection						
Int Delay, s/veh	6					
Movement	EBT	EBR	WBL	WBT	NBL	NBR
Lane Configurations	↔		↔	↑	↔	↔
Traffic Vol, veh/h	123	30	242	44	23	116
Future Vol, veh/h	123	30	242	44	23	116
Conflicting Peds, #/hr	0	0	0	0	0	0
Sign Control	Free	Free	Free	Free	Stop	Stop
RT Channelized	-	None	-	None	-	None
Storage Length	-	-	100	-	0	0
Veh in Median Storage, #	0	-	-	0	0	-
Grade, %	0	-	-	0	0	-
Peak Hour Factor	92	92	92	92	92	92
Heavy Vehicles, %	2	2	2	2	2	2
Mvmt Flow	134	33	263	48	25	126

Major/Minor	Major1	Major2	Minor1		
Conflicting Flow All	0	0	167	0	725
Stage 1	-	-	-	-	151
Stage 2	-	-	-	-	574
Critical Hdwy	-	-	4.12	-	6.42
Critical Hdwy Stg 1	-	-	-	-	5.42
Critical Hdwy Stg 2	-	-	-	-	5.42
Follow-up Hdwy	-	-	2.218	-	3.518
Pot Cap-1 Maneuver	-	-	1411	-	392
Stage 1	-	-	-	-	877
Stage 2	-	-	-	-	563
Platoon blocked, %	-	-	-	-	-
Mov Cap-1 Maneuver	-	-	1411	-	319
Mov Cap-2 Maneuver	-	-	-	-	319
Stage 1	-	-	-	-	877
Stage 2	-	-	-	-	458

Approach	EB	WB	NB
HCM Control Delay, s	0	6.9	10.9
HCM LOS			B

Minor Lane/Major Mvmt	NBLn1	NBLn2	EBT	EBR	WBL	WBT
Capacity (veh/h)	319	895	-	-	1411	-
HCM Lane V/C Ratio	0.078	0.141	-	-	0.186	-
HCM Control Delay (s)	17.2	9.7	-	-	8.1	-
HCM Lane LOS	C	A	-	-	A	-
HCM 95th %tile Q(veh)	0.3	0.5	-	-	0.7	-

Intersection						
Int Delay, s/veh	0.7					
Movement	EBL	EBR	NBL	NBT	SBT	SBR
Lane Configurations		↗		↕↕	↕↕	↗
Traffic Vol, veh/h	0	92	0	760	713	30
Future Vol, veh/h	0	92	0	760	713	30
Conflicting Peds, #/hr	0	0	0	0	0	0
Sign Control	Stop	Stop	Free	Free	Free	Free
RT Channelized	-	None	-	None	-	None
Storage Length	-	0	-	-	-	100
Veh in Median Storage, #	0	-	-	0	0	-
Grade, %	0	-	-	0	0	-
Peak Hour Factor	92	92	92	92	92	92
Heavy Vehicles, %	2	2	2	2	2	2
Mvmt Flow	0	100	0	826	775	33

Major/Minor	Minor2	Major1	Major2		
Conflicting Flow All	-	388	-	0	-
Stage 1	-	-	-	-	-
Stage 2	-	-	-	-	-
Critical Hdwy	-	6.94	-	-	-
Critical Hdwy Stg 1	-	-	-	-	-
Critical Hdwy Stg 2	-	-	-	-	-
Follow-up Hdwy	-	3.32	-	-	-
Pot Cap-1 Maneuver	0	611	0	-	-
Stage 1	0	-	0	-	-
Stage 2	0	-	0	-	-
Platoon blocked, %				-	-
Mov Cap-1 Maneuver	-	611	-	-	-
Mov Cap-2 Maneuver	-	-	-	-	-
Stage 1	-	-	-	-	-
Stage 2	-	-	-	-	-

Approach	EB	NB	SB
HCM Control Delay, s	12	0	0
HCM LOS	B		

Minor Lane/Major Mvmt	NBT EBLn1	SBT	SBR
Capacity (veh/h)	- 611	-	-
HCM Lane V/C Ratio	- 0.164	-	-
HCM Control Delay (s)	- 12	-	-
HCM Lane LOS	- B	-	-
HCM 95th %tile Q(veh)	- 0.6	-	-

Heritage at Dalia Ranch
1: SR-86 & Keystone Rd

Opening Year 2026 + P1-3 Proj
Timing Plan: PM PEAK

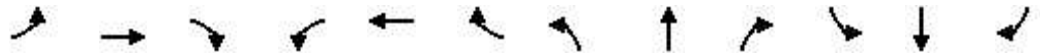

Movement	EBL	EBT	EBR	WBL	WBT	WBR	NBL	NBT	NBR	SBL	SBT	SBR
Lane Configurations		↕			↕		↗	↕	↗	↗	↗	↕
Traffic Volume (veh/h)	43	13	20	34	28	39	11	630	27	55	672	35
Future Volume (veh/h)	43	13	20	34	28	39	11	630	27	55	672	35
Initial Q (Qb), veh	0	0	0	0	0	0	0	0	0	0	0	0
Ped-Bike Adj(A_pbT)	1.00		1.00	1.00		1.00	1.00		1.00	1.00		1.00
Parking Bus, Adj	1.00	1.00	1.00	1.00	1.00	1.00	1.00	1.00	1.00	1.00	1.00	1.00
Work Zone On Approach		No			No			No			No	
Adj Sat Flow, veh/h/ln	1870	1870	1870	1870	1870	1870	1870	1870	1870	1870	1870	1870
Adj Flow Rate, veh/h	48	15	22	38	31	44	12	708	30	62	755	39
Peak Hour Factor	0.89	0.89	0.89	0.89	0.89	0.89	0.89	0.89	0.89	0.89	0.89	0.89
Percent Heavy Veh, %	2	2	2	2	2	2	2	2	2	2	2	2
Cap, veh/h	273	52	54	205	70	81	28	1245	556	117	1423	635
Arrive On Green	0.13	0.13	0.13	0.13	0.13	0.13	0.02	0.35	0.35	0.07	0.40	0.40
Sat Flow, veh/h	798	410	422	457	548	641	1781	3554	1585	1781	3554	1585
Grp Volume(v), veh/h	85	0	0	113	0	0	12	708	30	62	755	39
Grp Sat Flow(s),veh/h/ln	1630	0	0	1645	0	0	1781	1777	1585	1781	1777	1585
Q Serve(g_s), s	0.0	0.0	0.0	0.6	0.0	0.0	0.2	5.3	0.4	1.1	5.3	0.5
Cycle Q Clear(g_c), s	1.4	0.0	0.0	2.0	0.0	0.0	0.2	5.3	0.4	1.1	5.3	0.5
Prop In Lane	0.56		0.26	0.34		0.39	1.00		1.00	1.00		1.00
Lane Grp Cap(c), veh/h	379	0	0	356	0	0	28	1245	556	117	1423	635
V/C Ratio(X)	0.22	0.00	0.00	0.32	0.00	0.00	0.43	0.57	0.05	0.53	0.53	0.06
Avail Cap(c_a), veh/h	994	0	0	1015	0	0	271	2271	1013	325	2380	1061
HCM Platoon Ratio	1.00	1.00	1.00	1.00	1.00	1.00	1.00	1.00	1.00	1.00	1.00	1.00
Upstream Filter(l)	1.00	0.00	0.00	1.00	0.00	0.00	1.00	1.00	1.00	1.00	1.00	1.00
Uniform Delay (d), s/veh	13.1	0.0	0.0	13.4	0.0	0.0	16.0	8.7	7.1	14.9	7.5	6.1
Incr Delay (d2), s/veh	0.3	0.0	0.0	0.5	0.0	0.0	9.9	0.4	0.0	3.7	0.3	0.0
Initial Q Delay(d3),s/veh	0.0	0.0	0.0	0.0	0.0	0.0	0.0	0.0	0.0	0.0	0.0	0.0
%ile BackOfQ(50%),veh/ln	0.5	0.0	0.0	0.7	0.0	0.0	0.2	1.4	0.1	0.5	1.3	0.1
Unsig. Movement Delay, s/veh												
LnGrp Delay(d),s/veh	13.4	0.0	0.0	13.9	0.0	0.0	25.9	9.1	7.1	18.5	7.8	6.1
LnGrp LOS	B	A	A	B	A	A	C	A	A	B	A	A
Approach Vol, veh/h		85			113			750			856	
Approach Delay, s/veh		13.4			13.9			9.3			8.5	
Approach LOS		B			B			A			A	
Timer - Assigned Phs	1	2		4	5	6		8				
Phs Duration (G+Y+Rc), s	7.2	16.5		9.2	5.5	18.2		9.2				
Change Period (Y+Rc), s	5.0	5.0		5.0	5.0	5.0		5.0				
Max Green Setting (Gmax), s	6.0	21.0		18.0	5.0	22.0		18.0				
Max Q Clear Time (g_c+I1), s	3.1	7.3		3.4	2.2	7.3		4.0				
Green Ext Time (p_c), s	0.0	4.2		0.3	0.0	4.7		0.4				
Intersection Summary												
HCM 6th Ctrl Delay				9.4								
HCM 6th LOS				A								

Intersection												
Int Delay, s/veh	0.3											
Movement	EBL	EBT	EBR	WBL	WBT	WBR	NBL	NBT	NBR	SBL	SBT	SBR
Lane Configurations		↕			↕		↕	↕		↕	↕	
Traffic Vol, veh/h	6	4	0	8	0	5	1	669	8	6	709	18
Future Vol, veh/h	6	4	0	8	0	5	1	669	8	6	709	18
Conflicting Peds, #/hr	0	0	0	0	0	0	0	0	0	0	0	0
Sign Control	Stop	Stop	Stop	Stop	Stop	Stop	Free	Free	Free	Free	Free	Free
RT Channelized	-	-	None	-	-	None	-	-	None	-	-	None
Storage Length	-	-	-	-	-	-	50	-	-	50	-	-
Veh in Median Storage, #	-	1	-	-	1	-	-	0	-	-	0	-
Grade, %	-	0	-	-	0	-	-	0	-	-	0	-
Peak Hour Factor	92	92	92	92	92	92	92	92	92	92	92	92
Heavy Vehicles, %	2	2	2	2	2	2	2	2	2	2	2	2
Mvmt Flow	7	4	0	9	0	5	1	727	9	7	771	20

Major/Minor	Minor2		Minor1		Major1		Major2					
Conflicting Flow All	1161	1533	396	1136	1539	368	791	0	0	736	0	0
Stage 1	795	795	-	734	734	-	-	-	-	-	-	-
Stage 2	366	738	-	402	805	-	-	-	-	-	-	-
Critical Hdwy	7.54	6.54	6.94	7.54	6.54	6.94	4.14	-	-	4.14	-	-
Critical Hdwy Stg 1	6.54	5.54	-	6.54	5.54	-	-	-	-	-	-	-
Critical Hdwy Stg 2	6.54	5.54	-	6.54	5.54	-	-	-	-	-	-	-
Follow-up Hdwy	3.52	4.02	3.32	3.52	4.02	3.32	2.22	-	-	2.22	-	-
Pot Cap-1 Maneuver	150	115	603	157	115	629	825	-	-	865	-	-
Stage 1	347	398	-	378	424	-	-	-	-	-	-	-
Stage 2	626	422	-	596	393	-	-	-	-	-	-	-
Platoon blocked, %								-	-	-	-	-
Mov Cap-1 Maneuver	148	114	603	154	114	629	825	-	-	865	-	-
Mov Cap-2 Maneuver	262	237	-	275	237	-	-	-	-	-	-	-
Stage 1	347	395	-	378	424	-	-	-	-	-	-	-
Stage 2	620	422	-	585	390	-	-	-	-	-	-	-

Approach	EB		WB		NB		SB	
HCM Control Delay, s	20		15.7		0		0.1	
HCM LOS	C		C					

Minor Lane/Major Mvmt	NBL	NBT	NBR	EBLn1	WBLn1	SBL	SBT	SBR
Capacity (veh/h)	825	-	-	251	351	865	-	-
HCM Lane V/C Ratio	0.001	-	-	0.043	0.04	0.008	-	-
HCM Control Delay (s)	9.4	-	-	20	15.7	9.2	-	-
HCM Lane LOS	A	-	-	C	C	A	-	-
HCM 95th %tile Q(veh)	0	-	-	0.1	0.1	0	-	-

Heritage at Dalia Ranch
3: Imperial Ave & Ralph Rd

Opening Year 2026 + P1-3 Proj
Timing Plan: PM PEAK

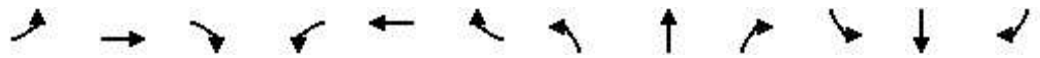

Movement	EBL	EBT	EBR	WBL	WBT	WBR	NBL	NBT	NBR	SBL	SBT	SBR
Lane Configurations	↖	↗		↖	↗		↖	↕	↗	↖	↕	↗
Traffic Volume (veh/h)	66	22	90	20	18	11	192	604	31	31	613	59
Future Volume (veh/h)	66	22	90	20	18	11	192	604	31	31	613	59
Initial Q (Qb), veh	0	0	0	0	0	0	0	0	0	0	0	0
Ped-Bike Adj(A_pbT)	1.00		1.00	1.00		1.00	1.00		1.00	1.00		1.00
Parking Bus, Adj	1.00	1.00	1.00	1.00	1.00	1.00	1.00	1.00	1.00	1.00	1.00	1.00
Work Zone On Approach		No			No			No			No	
Adj Sat Flow, veh/h/ln	1870	1870	1870	1870	1870	1870	1870	1870	1870	1870	1870	1870
Adj Flow Rate, veh/h	72	24	98	22	20	12	209	664	34	34	674	64
Peak Hour Factor	0.92	0.92	0.92	0.91	0.92	0.91	0.92	0.91	0.91	0.91	0.91	0.92
Percent Heavy Veh, %	2	2	2	2	2	2	2	2	2	2	2	2
Cap, veh/h	172	37	152	149	113	68	218	1220	62	67	960	428
Arrive On Green	0.10	0.12	0.12	0.08	0.10	0.10	0.12	0.35	0.35	0.04	0.27	0.27
Sat Flow, veh/h	1781	321	1313	1781	1095	657	1781	3440	176	1781	3554	1585
Grp Volume(v), veh/h	72	0	122	22	0	32	209	343	355	34	674	64
Grp Sat Flow(s),veh/h/ln	1781	0	1634	1781	0	1752	1781	1777	1839	1781	1777	1585
Q Serve(g_s), s	1.9	0.0	3.5	0.6	0.0	0.8	5.7	7.6	7.6	0.9	8.4	1.5
Cycle Q Clear(g_c), s	1.9	0.0	3.5	0.6	0.0	0.8	5.7	7.6	7.6	0.9	8.4	1.5
Prop In Lane	1.00		0.80	1.00		0.38	1.00		0.10	1.00		1.00
Lane Grp Cap(c), veh/h	172	0	190	149	0	180	218	630	652	67	960	428
V/C Ratio(X)	0.42	0.00	0.64	0.15	0.00	0.18	0.96	0.54	0.54	0.50	0.70	0.15
Avail Cap(c_a), veh/h	654	0	600	654	0	643	218	689	713	182	1305	582
HCM Platoon Ratio	1.00	1.00	1.00	1.00	1.00	1.00	1.00	1.00	1.00	1.00	1.00	1.00
Upstream Filter(l)	1.00	0.00	1.00	1.00	0.00	1.00	1.00	1.00	1.00	1.00	1.00	1.00
Uniform Delay (d), s/veh	20.8	0.0	20.7	20.8	0.0	20.1	21.4	12.7	12.7	23.1	16.1	13.6
Incr Delay (d2), s/veh	1.6	0.0	3.6	0.5	0.0	0.5	49.2	0.7	0.7	5.7	1.1	0.2
Initial Q Delay(d3),s/veh	0.0	0.0	0.0	0.0	0.0	0.0	0.0	0.0	0.0	0.0	0.0	0.0
%ile BackOfQ(50%),veh/ln	0.8	0.0	1.4	0.2	0.0	0.3	5.1	2.6	2.7	0.5	3.1	0.5
Unsig. Movement Delay, s/veh												
LnGrp Delay(d),s/veh	22.5	0.0	24.3	21.3	0.0	20.6	70.5	13.4	13.4	28.9	17.2	13.8
LnGrp LOS	C	A	C	C	A	C	E	B	B	C	B	B
Approach Vol, veh/h		194			54			907			772	
Approach Delay, s/veh		23.6			20.9			26.5			17.4	
Approach LOS		C			C			C			B	
Timer - Assigned Phs	1	2	3	4	5	6	7	8				
Phs Duration (G+Y+Rc), s	6.9	22.4	9.1	10.7	11.0	18.2	9.7	10.1				
Change Period (Y+Rc), s	5.0	5.0	5.0	5.0	5.0	5.0	5.0	5.0				
Max Green Setting (Gmax), s	5.0	19.0	18.0	18.0	6.0	18.0	18.0	18.0				
Max Q Clear Time (g_c+I1), s	2.9	9.6	2.6	5.5	7.7	10.4	3.9	2.8				
Green Ext Time (p_c), s	0.0	3.0	0.0	0.5	0.0	2.9	0.1	0.1				
Intersection Summary												
HCM 6th Ctrl Delay			22.4									
HCM 6th LOS			C									

Heritage at Dalia Ranch
4: Imperial Ave & Neckel Rd

Opening Year 2026 + P1-3 Proj
Timing Plan: PM PEAK



Movement	EBL	EBT	EBR	WBL	WBT	WBR	NBL	NBT	NBR	SBL	SBT	SBR
Lane Configurations		↕			↕		↕	↕		↕	↕	
Traffic Volume (veh/h)	13	27	38	139	20	84	71	754	178	82	672	29
Future Volume (veh/h)	13	27	38	139	20	84	71	754	178	82	672	29
Initial Q (Qb), veh	0	0	0	0	0	0	0	0	0	0	0	0
Ped-Bike Adj(A_pbT)	1.00		1.00	1.00		1.00	1.00		1.00	1.00		1.00
Parking Bus, Adj	1.00	1.00	1.00	1.00	1.00	1.00	1.00	1.00	1.00	1.00	1.00	1.00
Work Zone On Approach		No			No			No			No	
Adj Sat Flow, veh/h/ln	1870	1870	1870	1870	1870	1870	1870	1870	1870	1870	1870	1870
Adj Flow Rate, veh/h	14	29	41	151	22	91	77	820	193	89	730	32
Peak Hour Factor	0.92	0.92	0.92	0.92	0.92	0.92	0.92	0.92	0.92	0.92	0.92	0.92
Percent Heavy Veh, %	2	2	2	2	2	2	2	2	2	2	2	2
Cap, veh/h	18	38	54	191	28	115	110	924	217	118	1138	50
Arrive On Green	0.06	0.06	0.06	0.19	0.19	0.19	0.06	0.32	0.32	0.07	0.33	0.33
Sat Flow, veh/h	284	589	833	981	143	591	1781	2854	672	1781	3468	152
Grp Volume(v), veh/h	84	0	0	264	0	0	77	510	503	89	374	388
Grp Sat Flow(s),veh/h/ln	1706	0	0	1715	0	0	1781	1777	1749	1781	1777	1843
Q Serve(g_s), s	2.8	0.0	0.0	8.4	0.0	0.0	2.4	15.5	15.6	2.8	10.2	10.2
Cycle Q Clear(g_c), s	2.8	0.0	0.0	8.4	0.0	0.0	2.4	15.5	15.6	2.8	10.2	10.2
Prop In Lane	0.17		0.49	0.57		0.34	1.00		0.38	1.00		0.08
Lane Grp Cap(c), veh/h	111	0	0	333	0	0	110	575	566	118	583	605
V/C Ratio(X)	0.76	0.00	0.00	0.79	0.00	0.00	0.70	0.89	0.89	0.75	0.64	0.64
Avail Cap(c_a), veh/h	538	0	0	541	0	0	156	592	583	156	592	614
HCM Platoon Ratio	1.00	1.00	1.00	1.00	1.00	1.00	1.00	1.00	1.00	1.00	1.00	1.00
Upstream Filter(I)	1.00	0.00	0.00	1.00	0.00	0.00	1.00	1.00	1.00	1.00	1.00	1.00
Uniform Delay (d), s/veh	26.2	0.0	0.0	21.9	0.0	0.0	26.2	18.3	18.3	26.2	16.3	16.3
Incr Delay (d2), s/veh	10.0	0.0	0.0	4.2	0.0	0.0	7.8	14.9	15.1	13.6	2.3	2.2
Initial Q Delay(d3),s/veh	0.0	0.0	0.0	0.0	0.0	0.0	0.0	0.0	0.0	0.0	0.0	0.0
%ile BackOfQ(50%),veh/ln	1.4	0.0	0.0	3.5	0.0	0.0	1.2	8.0	7.9	1.6	4.0	4.2
Unsig. Movement Delay, s/veh												
LnGrp Delay(d),s/veh	36.3	0.0	0.0	26.1	0.0	0.0	34.0	33.2	33.4	39.8	18.6	18.5
LnGrp LOS	D	A	A	C	A	A	C	C	C	D	B	B
Approach Vol, veh/h		84		264			1090			851		
Approach Delay, s/veh		36.3		26.1			33.4			20.8		
Approach LOS		D		C			C			C		
Timer - Assigned Phs	1	2		4	5	6		8				
Phs Duration (G+Y+Rc), s	8.8	23.5		8.7	8.5	23.7		16.1				
Change Period (Y+Rc), s	5.0	5.0		5.0	5.0	5.0		5.0				
Max Green Setting (Gmax), s	5.0	19.0		18.0	5.0	19.0		18.0				
Max Q Clear Time (g_c+14), s	14.8	17.6		4.8	4.4	12.2		10.4				
Green Ext Time (p_c), s	0.0	0.9		0.3	0.0	2.6		0.9				
Intersection Summary												
HCM 6th Ctrl Delay				28.0								
HCM 6th LOS				C								

Intersection												
Int Delay, s/veh	8.4											
Movement	EBL	EBT	EBR	WBL	WBT	WBR	NBL	NBT	NBR	SBL	SBT	SBR
Lane Configurations		↕			↕			↕			↕	
Traffic Vol, veh/h	2	40	9	29	46	105	5	36	19	94	34	8
Future Vol, veh/h	2	40	9	29	46	105	5	36	19	94	34	8
Conflicting Peds, #/hr	0	0	0	0	0	0	0	0	0	0	0	0
Sign Control	Stop	Stop	Stop	Stop	Stop	Stop	Free	Free	Free	Free	Free	Free
RT Channelized	-	-	None	-	-	None	-	-	None	-	-	None
Storage Length	-	-	-	-	-	-	-	-	-	-	-	-
Veh in Median Storage, #	-	0	-	-	0	-	-	0	-	-	0	-
Grade, %	-	0	-	-	0	-	-	0	-	-	0	-
Peak Hour Factor	79	79	79	79	79	79	79	79	79	79	79	79
Heavy Vehicles, %	2	2	2	2	2	2	2	2	2	2	2	2
Mvmt Flow	3	51	11	37	58	133	6	46	24	119	43	10

Major/Minor	Minor2		Minor1		Major1			Major2				
Conflicting Flow All	452	368	48	387	361	58	53	0	0	70	0	0
Stage 1	286	286	-	70	70	-	-	-	-	-	-	-
Stage 2	166	82	-	317	291	-	-	-	-	-	-	-
Critical Hdwy	7.12	6.52	6.22	7.12	6.52	6.22	4.12	-	-	4.12	-	-
Critical Hdwy Stg 1	6.12	5.52	-	6.12	5.52	-	-	-	-	-	-	-
Critical Hdwy Stg 2	6.12	5.52	-	6.12	5.52	-	-	-	-	-	-	-
Follow-up Hdwy	3.518	4.018	3.318	3.518	4.018	3.318	2.218	-	-	2.218	-	-
Pot Cap-1 Maneuver	518	561	1021	572	566	1008	1553	-	-	1531	-	-
Stage 1	721	675	-	940	837	-	-	-	-	-	-	-
Stage 2	836	827	-	694	672	-	-	-	-	-	-	-
Platoon blocked, %								-	-	-	-	-
Mov Cap-1 Maneuver	385	514	1021	490	518	1008	1553	-	-	1531	-	-
Mov Cap-2 Maneuver	385	514	-	490	518	-	-	-	-	-	-	-
Stage 1	718	621	-	936	834	-	-	-	-	-	-	-
Stage 2	672	824	-	580	618	-	-	-	-	-	-	-

Approach	EB		WB		NB		SB	
HCM Control Delay, s	12.3		12.4		0.6		5.2	
HCM LOS	B		B					

Minor Lane/Major Mvmt	NBL	NBT	NBR	EBLn1	WBLn1	SBL	SBT	SBR
Capacity (veh/h)	1553	-	-	555	714	1531	-	-
HCM Lane V/C Ratio	0.004	-	-	0.116	0.319	0.078	-	-
HCM Control Delay (s)	7.3	0	-	12.3	12.4	7.5	0	-
HCM Lane LOS	A	A	-	B	B	A	A	-
HCM 95th %tile Q(veh)	0	-	-	0.4	1.4	0.3	-	-

Heritage at Dalia Ranch
6: Imperial Ave & Worthington Rd/Barioni Blvd

Opening Year 2026 + P1-3 Proj
Timing Plan: PM PEAK



Movement	EBL	EBT	EBR	WBL	WBT	WBR	NBL	NBT	NBR	SBL	SBT	SBR
Lane Configurations		↕	↗		↕	↗	↗	↕↗		↗	↕↗	
Traffic Volume (veh/h)	65	77	109	57	117	93	117	966	15	62	818	74
Future Volume (veh/h)	65	77	109	57	117	93	117	966	15	62	818	74
Initial Q (Qb), veh	0	0	0	0	0	0	0	0	0	0	0	0
Ped-Bike Adj(A_pbT)	1.00		1.00	1.00		1.00	1.00		1.00	1.00		1.00
Parking Bus, Adj	1.00	1.00	1.00	1.00	1.00	1.00	1.00	1.00	1.00	1.00	1.00	1.00
Work Zone On Approach		No			No			No			No	
Adj Sat Flow, veh/h/ln	1870	1870	1870	1870	1870	1870	1870	1870	1870	1870	1870	1870
Adj Flow Rate, veh/h	71	85	120	63	129	102	129	1062	16	68	899	81
Peak Hour Factor	0.91	0.91	0.91	0.91	0.91	0.91	0.91	0.91	0.91	0.91	0.91	0.91
Percent Heavy Veh, %	2	2	2	2	2	2	2	2	2	2	2	2
Cap, veh/h	107	128	204	89	183	234	164	1197	18	101	984	89
Arrive On Green	0.13	0.13	0.13	0.15	0.15	0.15	0.09	0.33	0.33	0.06	0.30	0.30
Sat Flow, veh/h	832	996	1585	604	1236	1585	1781	3583	54	1781	3297	297
Grp Volume(v), veh/h	156	0	120	192	0	102	129	527	551	68	485	495
Grp Sat Flow(s),veh/h/ln	1829	0	1585	1840	0	1585	1781	1777	1861	1781	1777	1817
Q Serve(g_s), s	4.9	0.0	4.3	6.0	0.0	3.5	4.3	16.8	16.8	2.2	15.8	15.8
Cycle Q Clear(g_c), s	4.9	0.0	4.3	6.0	0.0	3.5	4.3	16.8	16.8	2.2	15.8	15.8
Prop In Lane	0.46		1.00	0.33		1.00	1.00		0.03	1.00		0.16
Lane Grp Cap(c), veh/h	235	0	204	272	0	234	164	594	622	101	530	542
V/C Ratio(X)	0.66	0.00	0.59	0.71	0.00	0.44	0.79	0.89	0.89	0.68	0.91	0.91
Avail Cap(c_a), veh/h	548	0	475	551	0	475	178	594	622	148	533	545
HCM Platoon Ratio	1.00	1.00	1.00	1.00	1.00	1.00	1.00	1.00	1.00	1.00	1.00	1.00
Upstream Filter(l)	1.00	0.00	1.00	1.00	0.00	1.00	1.00	1.00	1.00	1.00	1.00	1.00
Uniform Delay (d), s/veh	24.9	0.0	24.7	24.3	0.0	23.3	26.7	18.9	18.9	27.8	20.3	20.3
Incr Delay (d2), s/veh	3.2	0.0	2.7	3.3	0.0	1.3	19.2	15.1	14.6	7.7	20.3	19.9
Initial Q Delay(d3),s/veh	0.0	0.0	0.0	0.0	0.0	0.0	0.0	0.0	0.0	0.0	0.0	0.0
%ile BackOfQ(50%),veh/ln	2.2	0.0	1.7	2.7	0.0	1.3	2.6	8.6	8.9	1.1	8.9	9.0
Unsig. Movement Delay, s/veh												
LnGrp Delay(d),s/veh	28.1	0.0	27.4	27.7	0.0	24.6	45.9	34.0	33.5	35.5	40.6	40.2
LnGrp LOS	C	A	C	C	A	C	D	C	C	D	D	D
Approach Vol, veh/h		276			294			1207			1048	
Approach Delay, s/veh		27.8			26.6			35.0			40.1	
Approach LOS		C			C			D			D	
Timer - Assigned Phs	1	2		4	5	6		8				
Phs Duration (G+Y+Rc), s	8.4	25.1		12.7	10.5	22.9		13.9				
Change Period (Y+Rc), s	5.0	5.0		5.0	5.0	5.0		5.0				
Max Green Setting (Gmax), s	5.0	19.0		18.0	6.0	18.0		18.0				
Max Q Clear Time (g_c+I1), s	4.2	18.8		6.9	6.3	17.8		8.0				
Green Ext Time (p_c), s	0.0	0.1		0.9	0.0	0.1		1.0				
Intersection Summary												
HCM 6th Ctrl Delay			35.3									
HCM 6th LOS			D									

Intersection												
Intersection Delay, s/veh	12.2											
Intersection LOS	B											

Movement	EBL	EBT	EBR	WBL	WBT	WBR	NBL	NBT	NBR	SBL	SBT	SBR
Lane Configurations		↔	↔		↔	↔		↔			↔	
Traffic Vol, veh/h	66	210	34	28	233	35	1	0	0	39	5	59
Future Vol, veh/h	66	210	34	28	233	35	1	0	0	39	5	59
Peak Hour Factor	0.80	0.80	0.80	0.80	0.80	0.80	0.80	0.80	0.80	0.80	0.80	0.80
Heavy Vehicles, %	2	2	2	2	2	2	2	2	2	2	2	2
Mvmt Flow	83	263	43	35	291	44	1	0	0	49	6	74
Number of Lanes	0	1	1	0	1	1	0	1	0	0	1	0

Approach	EB	WB	NB	SB
Opposing Approach	WB	EB	SB	NB
Opposing Lanes	2	2	1	1
Conflicting Approach Left	SB	NB	EB	WB
Conflicting Lanes Left	1	1	2	2
Conflicting Approach Right	NB	SB	WB	EB
Conflicting Lanes Right	1	1	2	2
HCM Control Delay	13	12.3	9.3	9.8
HCM LOS	B	B	A	A

Lane	NBLn1	EBLn1	EBLn2	WBLn1	WBLn2	SBLn1
Vol Left, %	100%	24%	0%	11%	0%	38%
Vol Thru, %	0%	76%	0%	89%	0%	5%
Vol Right, %	0%	0%	100%	0%	100%	57%
Sign Control	Stop	Stop	Stop	Stop	Stop	Stop
Traffic Vol by Lane	1	276	34	261	35	103
LT Vol	1	66	0	28	0	39
Through Vol	0	210	0	233	0	5
RT Vol	0	0	34	0	35	59
Lane Flow Rate	1	345	42	326	44	129
Geometry Grp	2	7	7	7	7	2
Degree of Util (X)	0.002	0.512	0.053	0.48	0.055	0.194
Departure Headway (Hd)	6.276	5.343	4.518	5.297	4.538	5.421
Convergence, Y/N	Yes	Yes	Yes	Yes	Yes	Yes
Cap	574	669	786	675	782	657
Service Time	4.276	3.112	2.285	3.065	2.306	3.499
HCM Lane V/C Ratio	0.002	0.516	0.053	0.483	0.056	0.196
HCM Control Delay	9.3	13.7	7.5	12.9	7.6	9.8
HCM Lane LOS	A	B	A	B	A	A
HCM 95th-tile Q	0	2.9	0.2	2.6	0.2	0.7

Heritage at Dalia Ranch
8: Imperial Ave & Aten Rd

Opening Year 2026 + P1-3 Proj
Timing Plan: PM PEAK



Movement	EBL	EBT	EBR	WBL	WBT	WBR	NBL	NBT	NBR	SBL	SBT	SBR
Lane Configurations												
Traffic Volume (veh/h)	251	287	71	185	300	167	81	871	155	151	685	261
Future Volume (veh/h)	251	287	71	185	300	167	81	871	155	151	685	261
Initial Q (Qb), veh	0	0	0	0	0	0	0	0	0	0	0	0
Ped-Bike Adj(A_pbT)	1.00		1.00	1.00		1.00	1.00		1.00	1.00		1.00
Parking Bus, Adj	1.00	1.00	1.00	1.00	1.00	1.00	1.00	1.00	1.00	1.00	1.00	1.00
Work Zone On Approach		No		No		No		No		No		No
Adj Sat Flow, veh/h/ln	1870	1870	1870	1870	1870	1870	1870	1870	1870	1870	1870	1870
Adj Flow Rate, veh/h	267	305	76	197	319	178	86	927	165	161	729	278
Peak Hour Factor	0.94	0.94	0.94	0.94	0.94	0.94	0.94	0.94	0.94	0.94	0.94	0.94
Percent Heavy Veh, %	2	2	2	2	2	2	2	2	2	2	2	2
Cap, veh/h	278	601	147	239	423	231	110	959	428	177	1092	487
Arrive On Green	0.16	0.21	0.21	0.13	0.19	0.19	0.06	0.27	0.27	0.10	0.31	0.31
Sat Flow, veh/h	1781	2828	694	1781	2219	1210	1781	3554	1585	1781	3554	1585
Grp Volume(v), veh/h	267	190	191	197	254	243	86	927	165	161	729	278
Grp Sat Flow(s),veh/h/ln	1781	1777	1745	1781	1777	1652	1781	1777	1585	1781	1777	1585
Q Serve(g_s), s	10.5	6.6	6.8	7.6	9.5	9.8	3.4	18.1	6.0	6.3	12.6	10.4
Cycle Q Clear(g_c), s	10.5	6.6	6.8	7.6	9.5	9.8	3.4	18.1	6.0	6.3	12.6	10.4
Prop In Lane	1.00		0.40	1.00		0.73	1.00		1.00	1.00		1.00
Lane Grp Cap(c), veh/h	278	377	371	239	338	315	110	959	428	177	1092	487
V/C Ratio(X)	0.96	0.50	0.52	0.82	0.75	0.77	0.78	0.97	0.39	0.91	0.67	0.57
Avail Cap(c_a), veh/h	278	454	446	278	454	422	152	959	428	177	1092	487
HCM Platoon Ratio	1.00	1.00	1.00	1.00	1.00	1.00	1.00	1.00	1.00	1.00	1.00	1.00
Upstream Filter(l)	1.00	1.00	1.00	1.00	1.00	1.00	1.00	1.00	1.00	1.00	1.00	1.00
Uniform Delay (d), s/veh	29.5	24.4	24.5	29.7	26.9	27.0	32.5	25.4	21.0	31.4	21.3	20.5
Incr Delay (d2), s/veh	42.8	1.0	1.1	15.9	4.7	6.1	15.9	21.3	0.6	42.7	1.6	1.6
Initial Q Delay(d3),s/veh	0.0	0.0	0.0	0.0	0.0	0.0	0.0	0.0	0.0	0.0	0.0	0.0
%ile BackOfQ(50%),veh/ln	7.6	2.8	2.8	4.2	4.3	4.2	1.9	10.0	2.2	4.7	5.1	3.8
Unsig. Movement Delay, s/veh												
LnGrp Delay(d),s/veh	72.3	25.5	25.6	45.6	31.7	33.2	48.4	46.7	21.5	74.1	22.8	22.1
LnGrp LOS	E	C	C	D	C	C	D	D	C	E	C	C
Approach Vol, veh/h		648			694			1178			1168	
Approach Delay, s/veh		44.8			36.1			43.3			29.7	
Approach LOS		D			D			D			C	
Timer - Assigned Phs	1	2	3	4	5	6	7	8				
Phs Duration (G+Y+Rc), s	24.0	14.5	20.0	9.4	26.6	16.0	18.4					
Change Period (Y+Rc), s	5.0	5.0	5.0	5.0	5.0	5.0	5.0					
Max Green Setting (Gmax), s	19.0	11.0	18.0	6.0	20.0	11.0	18.0					
Max Q Clear Time (g_c+1/3), s	20.1	9.6	8.8	5.4	14.6	12.5	11.8					
Green Ext Time (p_c), s	0.0	0.0	0.1	1.5	0.0	2.7	0.0	1.6				

Intersection Summary

HCM 6th Ctrl Delay	37.9
HCM 6th LOS	D

Intersection						
Int Delay, s/veh	2.1					
Movement	EBL	EBT	WBT	WBR	SBL	SBR
Lane Configurations	↔	↑	↔		↔	↔
Traffic Vol, veh/h	8	44	61	59	34	5
Future Vol, veh/h	8	44	61	59	34	5
Conflicting Peds, #/hr	0	0	0	0	0	0
Sign Control	Free	Free	Free	Free	Stop	Stop
RT Channelized	-	None	-	None	-	None
Storage Length	50	-	-	-	0	0
Veh in Median Storage, #	-	0	0	-	0	-
Grade, %	-	0	0	-	0	-
Peak Hour Factor	92	92	92	92	92	92
Heavy Vehicles, %	2	2	2	2	2	2
Mvmt Flow	9	48	66	64	37	5

Major/Minor	Major1	Major2	Minor2		
Conflicting Flow All	130	0	-	0	164 98
Stage 1	-	-	-	-	98 -
Stage 2	-	-	-	-	66 -
Critical Hdwy	4.12	-	-	-	6.42 6.22
Critical Hdwy Stg 1	-	-	-	-	5.42 -
Critical Hdwy Stg 2	-	-	-	-	5.42 -
Follow-up Hdwy	2.218	-	-	-	3.518 3.318
Pot Cap-1 Maneuver	1455	-	-	-	827 958
Stage 1	-	-	-	-	926 -
Stage 2	-	-	-	-	957 -
Platoon blocked, %		-	-	-	
Mov Cap-1 Maneuver	1455	-	-	-	822 958
Mov Cap-2 Maneuver	-	-	-	-	822 -
Stage 1	-	-	-	-	920 -
Stage 2	-	-	-	-	957 -

Approach	EB	WB	SB
HCM Control Delay, s	1.2	0	9.5
HCM LOS			A

Minor Lane/Major Mvmt	EBL	EBT	WBT	WBR	SBLn1	SBLn2
Capacity (veh/h)	1455	-	-	-	822	958
HCM Lane V/C Ratio	0.006	-	-	-	0.045	0.006
HCM Control Delay (s)	7.5	-	-	-	9.6	8.8
HCM Lane LOS	A	-	-	-	A	A
HCM 95th %tile Q(veh)	0	-	-	-	0.1	0

Intersection						
Int Delay, s/veh	0.4					
Movement	WBL	WBR	NBT	NBR	SBL	SBT
Lane Configurations	↶	↷	↶		↶	↷
Traffic Vol, veh/h	5	0	48	8	0	51
Future Vol, veh/h	5	0	48	8	0	51
Conflicting Peds, #/hr	0	0	0	0	0	0
Sign Control	Stop	Stop	Free	Free	Free	Free
RT Channelized	-	None	-	None	-	None
Storage Length	0	0	-	-	50	-
Veh in Median Storage, #	0	-	0	-	-	0
Grade, %	0	-	0	-	-	0
Peak Hour Factor	92	92	92	92	92	92
Heavy Vehicles, %	2	2	2	2	2	2
Mvmt Flow	5	0	52	9	0	55

Major/Minor	Minor1	Major1	Major2			
Conflicting Flow All	112	57	0	0	61	0
Stage 1	57	-	-	-	-	-
Stage 2	55	-	-	-	-	-
Critical Hdwy	6.42	6.22	-	-	4.12	-
Critical Hdwy Stg 1	5.42	-	-	-	-	-
Critical Hdwy Stg 2	5.42	-	-	-	-	-
Follow-up Hdwy	3.518	3.318	-	-	2.218	-
Pot Cap-1 Maneuver	885	1009	-	-	1542	-
Stage 1	966	-	-	-	-	-
Stage 2	968	-	-	-	-	-
Platoon blocked, %			-	-		-
Mov Cap-1 Maneuver	885	1009	-	-	1542	-
Mov Cap-2 Maneuver	885	-	-	-	-	-
Stage 1	966	-	-	-	-	-
Stage 2	968	-	-	-	-	-

Approach	WB	NB	SB
HCM Control Delay, s	9.1	0	0
HCM LOS	A		

Minor Lane/Major Mvmt	NBT	NBRWBLn1	WBLn2	SBL	SBT
Capacity (veh/h)	-	-	885	-	1542
HCM Lane V/C Ratio	-	-	0.006	-	-
HCM Control Delay (s)	-	-	9.1	0	0
HCM Lane LOS	-	-	A	A	A
HCM 95th %tile Q(veh)	-	-	0	-	0

Intersection						
Int Delay, s/veh	5.2					
Movement	EBT	EBR	WBL	WBT	NBL	NBR
Lane Configurations	↔		↔	↑	↔	↔
Traffic Vol, veh/h	38	0	92	38	0	53
Future Vol, veh/h	38	0	92	38	0	53
Conflicting Peds, #/hr	0	0	0	0	0	0
Sign Control	Free	Free	Free	Free	Stop	Stop
RT Channelized	-	None	-	None	-	None
Storage Length	-	-	50	-	0	0
Veh in Median Storage, #	0	-	-	0	0	-
Grade, %	0	-	-	0	0	-
Peak Hour Factor	92	92	92	92	92	92
Heavy Vehicles, %	2	2	2	2	2	2
Mvmt Flow	41	0	100	41	0	58

Major/Minor	Major1	Major2	Minor1		
Conflicting Flow All	0	0	41	0	282 41
Stage 1	-	-	-	-	41 -
Stage 2	-	-	-	-	241 -
Critical Hdwy	-	-	4.12	-	6.42 6.22
Critical Hdwy Stg 1	-	-	-	-	5.42 -
Critical Hdwy Stg 2	-	-	-	-	5.42 -
Follow-up Hdwy	-	-	2.218	-	3.518 3.318
Pot Cap-1 Maneuver	-	-	1568	-	708 1030
Stage 1	-	-	-	-	981 -
Stage 2	-	-	-	-	799 -
Platoon blocked, %	-	-	-	-	-
Mov Cap-1 Maneuver	-	-	1568	-	663 1030
Mov Cap-2 Maneuver	-	-	-	-	663 -
Stage 1	-	-	-	-	981 -
Stage 2	-	-	-	-	748 -

Approach	EB	WB	NB
HCM Control Delay, s	0	5.3	8.7
HCM LOS			A

Minor Lane/Major Mvmt	NBLn1	NBLn2	EBT	EBR	WBL	WBT
Capacity (veh/h)	-	1030	-	-	1568	-
HCM Lane V/C Ratio	-	0.056	-	-	0.064	-
HCM Control Delay (s)	0	8.7	-	-	7.5	-
HCM Lane LOS	A	A	-	-	A	-
HCM 95th %tile Q(veh)	-	0.2	-	-	0.2	-

Intersection						
Int Delay, s/veh	1.5					
Movement	EBT	EBR	WBL	WBT	NBL	NBR
Lane Configurations						
Traffic Vol, veh/h	87	4	33	128	2	17
Future Vol, veh/h	87	4	33	128	2	17
Conflicting Peds, #/hr	0	0	0	0	0	0
Sign Control	Free	Free	Free	Free	Stop	Stop
RT Channelized	-	None	-	None	-	None
Storage Length	-	-	50	-	0	0
Veh in Median Storage, #	0	-	-	0	0	-
Grade, %	0	-	-	0	0	-
Peak Hour Factor	92	92	92	92	92	92
Heavy Vehicles, %	2	2	2	2	2	2
Mvmt Flow	95	4	36	139	2	18

Major/Minor	Major1	Major2	Minor1		
Conflicting Flow All	0	0	99	0	308 97
Stage 1	-	-	-	-	97 -
Stage 2	-	-	-	-	211 -
Critical Hdwy	-	-	4.12	-	6.42 6.22
Critical Hdwy Stg 1	-	-	-	-	5.42 -
Critical Hdwy Stg 2	-	-	-	-	5.42 -
Follow-up Hdwy	-	-	2.218	-	3.518 3.318
Pot Cap-1 Maneuver	-	-	1494	-	684 959
Stage 1	-	-	-	-	927 -
Stage 2	-	-	-	-	824 -
Platoon blocked, %	-	-	-	-	-
Mov Cap-1 Maneuver	-	-	1494	-	668 959
Mov Cap-2 Maneuver	-	-	-	-	668 -
Stage 1	-	-	-	-	927 -
Stage 2	-	-	-	-	804 -

Approach	EB	WB	NB
HCM Control Delay, s	0	1.5	9
HCM LOS			A

Minor Lane/Major Mvmt	NBLn1	NBLn2	EBT	EBR	WBL	WBT
Capacity (veh/h)	668	959	-	-	1494	-
HCM Lane V/C Ratio	0.003	0.019	-	-	0.024	-
HCM Control Delay (s)	10.4	8.8	-	-	7.5	-
HCM Lane LOS	B	A	-	-	A	-
HCM 95th %tile Q(veh)	0	0.1	-	-	0.1	-

Intersection						
Int Delay, s/veh	6.5					
Movement	EBT	EBR	WBL	WBT	NBL	NBR
Lane Configurations	↔		↔	↑	↔	↔
Traffic Vol, veh/h	70	34	270	125	36	180
Future Vol, veh/h	70	34	270	125	36	180
Conflicting Peds, #/hr	0	0	0	0	0	0
Sign Control	Free	Free	Free	Free	Stop	Stop
RT Channelized	-	None	-	None	-	None
Storage Length	-	-	100	-	0	0
Veh in Median Storage, #	0	-	-	0	0	-
Grade, %	0	-	-	0	0	-
Peak Hour Factor	92	92	92	92	92	92
Heavy Vehicles, %	2	2	2	2	2	2
Mvmt Flow	76	37	293	136	39	196

Major/Minor	Major1	Major2	Minor1		
Conflicting Flow All	0	0	113	0	817 95
Stage 1	-	-	-	-	95 -
Stage 2	-	-	-	-	722 -
Critical Hdwy	-	-	4.12	-	6.42 6.22
Critical Hdwy Stg 1	-	-	-	-	5.42 -
Critical Hdwy Stg 2	-	-	-	-	5.42 -
Follow-up Hdwy	-	-	2.218	-	3.518 3.318
Pot Cap-1 Maneuver	-	-	1476	-	346 962
Stage 1	-	-	-	-	929 -
Stage 2	-	-	-	-	481 -
Platoon blocked, %	-	-	-	-	-
Mov Cap-1 Maneuver	-	-	1476	-	277 962
Mov Cap-2 Maneuver	-	-	-	-	277 -
Stage 1	-	-	-	-	929 -
Stage 2	-	-	-	-	385 -

Approach	EB	WB	NB
HCM Control Delay, s	0	5.5	11.4
HCM LOS			B

Minor Lane/Major Mvmt	NBLn1	NBLn2	EBT	EBR	WBL	WBT
Capacity (veh/h)	277	962	-	-	1476	-
HCM Lane V/C Ratio	0.141	0.203	-	-	0.199	-
HCM Control Delay (s)	20.1	9.7	-	-	8	-
HCM Lane LOS	C	A	-	-	A	-
HCM 95th %tile Q(veh)	0.5	0.8	-	-	0.7	-

Intersection						
Int Delay, s/veh	1					
Movement	EBL	EBR	NBL	NBT	SBT	SBR
Lane Configurations		↗		↕↕	↕↕	↗
Traffic Vol, veh/h	0	144	0	904	704	34
Future Vol, veh/h	0	144	0	904	704	34
Conflicting Peds, #/hr	0	0	0	0	0	0
Sign Control	Stop	Stop	Free	Free	Free	Free
RT Channelized	-	None	-	None	-	None
Storage Length	-	0	-	-	-	100
Veh in Median Storage, #	0	-	-	0	0	-
Grade, %	0	-	-	0	0	-
Peak Hour Factor	92	92	92	92	92	92
Heavy Vehicles, %	2	2	2	2	2	2
Mvmt Flow	0	157	0	983	765	37

Major/Minor	Minor2	Major1	Major2
Conflicting Flow All	-	383	0
Stage 1	-	-	-
Stage 2	-	-	-
Critical Hdwy	-	6.94	-
Critical Hdwy Stg 1	-	-	-
Critical Hdwy Stg 2	-	-	-
Follow-up Hdwy	-	3.32	-
Pot Cap-1 Maneuver	0	615	0
Stage 1	0	-	0
Stage 2	0	-	0
Platoon blocked, %			-
Mov Cap-1 Maneuver	-	615	-
Mov Cap-2 Maneuver	-	-	-
Stage 1	-	-	-
Stage 2	-	-	-

Approach	EB	NB	SB
HCM Control Delay, s	12.8	0	0
HCM LOS	B		

Minor Lane/Major Mvmt	NBT EBLn1	SBT	SBR
Capacity (veh/h)	- 615	-	-
HCM Lane V/C Ratio	- 0.255	-	-
HCM Control Delay (s)	- 12.8	-	-
HCM Lane LOS	- B	-	-
HCM 95th %tile Q(veh)	- 1	-	-

Heritage at Dalia Ranch
1: SR-86 & Keystone Rd

Opening Year 2028
Timing Plan: AM PEAK

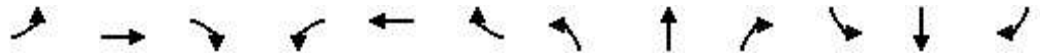

Movement	EBL	EBT	EBR	WBL	WBT	WBR	NBL	NBT	NBR	SBL	SBT	SBR
Lane Configurations		↕			↕		↗	↕	↗	↗	↕	↗
Traffic Volume (veh/h)	35	35	12	20	25	45	20	519	53	48	564	40
Future Volume (veh/h)	35	35	12	20	25	45	20	519	53	48	564	40
Initial Q (Qb), veh	0	0	0	0	0	0	0	0	0	0	0	0
Ped-Bike Adj(A_pbT)	1.00		1.00	1.00		1.00	1.00		1.00	1.00		1.00
Parking Bus, Adj	1.00	1.00	1.00	1.00	1.00	1.00	1.00	1.00	1.00	1.00	1.00	1.00
Work Zone On Approach		No			No			No			No	
Adj Sat Flow, veh/h/ln	1870	1870	1870	1870	1870	1870	1870	1870	1870	1870	1870	1870
Adj Flow Rate, veh/h	39	39	13	22	28	50	22	577	59	53	627	44
Peak Hour Factor	0.90	0.90	0.90	0.90	0.90	0.90	0.90	0.90	0.90	0.90	0.90	0.90
Percent Heavy Veh, %	2	2	2	2	2	2	2	2	2	2	2	2
Cap, veh/h	250	110	32	182	73	109	50	1095	488	106	1207	539
Arrive On Green	0.13	0.13	0.13	0.13	0.13	0.13	0.03	0.31	0.31	0.06	0.34	0.34
Sat Flow, veh/h	594	832	238	271	553	824	1781	3554	1585	1781	3554	1585
Grp Volume(v), veh/h	91	0	0	100	0	0	22	577	59	53	627	44
Grp Sat Flow(s),veh/h/ln	1664	0	0	1649	0	0	1781	1777	1585	1781	1777	1585
Q Serve(g_s), s	0.0	0.0	0.0	0.2	0.0	0.0	0.4	4.0	0.8	0.9	4.2	0.6
Cycle Q Clear(g_c), s	1.4	0.0	0.0	1.6	0.0	0.0	0.4	4.0	0.8	0.9	4.2	0.6
Prop In Lane	0.43		0.14	0.22		0.50	1.00		1.00	1.00		1.00
Lane Grp Cap(c), veh/h	392	0	0	365	0	0	50	1095	488	106	1207	539
V/C Ratio(X)	0.23	0.00	0.00	0.27	0.00	0.00	0.44	0.53	0.12	0.50	0.52	0.08
Avail Cap(c_a), veh/h	1117	0	0	1109	0	0	297	2131	950	297	2131	950
HCM Platoon Ratio	1.00	1.00	1.00	1.00	1.00	1.00	1.00	1.00	1.00	1.00	1.00	1.00
Upstream Filter(l)	1.00	0.00	0.00	1.00	0.00	0.00	1.00	1.00	1.00	1.00	1.00	1.00
Uniform Delay (d), s/veh	11.9	0.0	0.0	12.0	0.0	0.0	14.4	8.6	7.5	13.7	7.9	6.7
Incr Delay (d2), s/veh	0.3	0.0	0.0	0.4	0.0	0.0	6.1	0.4	0.1	3.6	0.3	0.1
Initial Q Delay(d3),s/veh	0.0	0.0	0.0	0.0	0.0	0.0	0.0	0.0	0.0	0.0	0.0	0.0
%ile BackOfQ(50%),veh/ln	0.4	0.0	0.0	0.5	0.0	0.0	0.2	1.1	0.2	0.4	1.1	0.1
Unsig. Movement Delay, s/veh												
LnGrp Delay(d),s/veh	12.2	0.0	0.0	12.4	0.0	0.0	20.4	9.0	7.6	17.3	8.3	6.8
LnGrp LOS	B	A	A	B	A	A	C	A	A	B	A	A
Approach Vol, veh/h		91			100			658			724	
Approach Delay, s/veh		12.2			12.4			9.2			8.9	
Approach LOS		B			B			A			A	
Timer - Assigned Phs	1	2		4	5	6		8				
Phs Duration (G+Y+Rc), s	6.8	14.3		9.0	5.8	15.2		9.0				
Change Period (Y+Rc), s	5.0	5.0		5.0	5.0	5.0		5.0				
Max Green Setting (Gmax), s	5.0	18.0		18.0	5.0	18.0		18.0				
Max Q Clear Time (g_c+I1), s	2.9	6.0		3.4	2.4	6.2		3.6				
Green Ext Time (p_c), s	0.0	3.2		0.3	0.0	3.4		0.4				
Intersection Summary												
HCM 6th Ctrl Delay				9.4								
HCM 6th LOS				A								

Intersection												
Int Delay, s/veh	0.4											
Movement	EBL	EBT	EBR	WBL	WBT	WBR	NBL	NBT	NBR	SBL	SBT	SBR
Lane Configurations		↕			↕		↕	↕		↕	↕	
Traffic Vol, veh/h	21	3	2	1	2	6	0	590	1	1	569	8
Future Vol, veh/h	21	3	2	1	2	6	0	590	1	1	569	8
Conflicting Peds, #/hr	0	0	0	0	0	0	0	0	0	0	0	0
Sign Control	Stop	Stop	Stop	Stop	Stop	Stop	Free	Free	Free	Free	Free	Free
RT Channelized	-	-	None	-	-	None	-	-	None	-	-	None
Storage Length	-	-	-	-	-	-	50	-	-	50	-	-
Veh in Median Storage, #	-	1	-	-	1	-	-	0	-	-	0	-
Grade, %	-	0	-	-	0	-	-	0	-	-	0	-
Peak Hour Factor	94	94	94	94	94	94	94	94	94	94	94	94
Heavy Vehicles, %	2	2	2	2	2	2	2	2	2	2	2	2
Mvmt Flow	22	3	2	1	2	6	0	628	1	1	605	9

Major/Minor	Minor2		Minor1		Major1			Major2				
Conflicting Flow All	927	1241	307	935	1245	315	614	0	0	629	0	0
Stage 1	612	612	-	629	629	-	-	-	-	-	-	-
Stage 2	315	629	-	306	616	-	-	-	-	-	-	-
Critical Hdwy	7.54	6.54	6.94	7.54	6.54	6.94	4.14	-	-	4.14	-	-
Critical Hdwy Stg 1	6.54	5.54	-	6.54	5.54	-	-	-	-	-	-	-
Critical Hdwy Stg 2	6.54	5.54	-	6.54	5.54	-	-	-	-	-	-	-
Follow-up Hdwy	3.52	4.02	3.32	3.52	4.02	3.32	2.22	-	-	2.22	-	-
Pot Cap-1 Maneuver	223	174	689	220	173	681	961	-	-	949	-	-
Stage 1	447	482	-	437	474	-	-	-	-	-	-	-
Stage 2	671	474	-	679	480	-	-	-	-	-	-	-
Platoon blocked, %								-	-	-	-	-
Mov Cap-1 Maneuver	219	174	689	217	173	681	961	-	-	949	-	-
Mov Cap-2 Maneuver	337	297	-	333	297	-	-	-	-	-	-	-
Stage 1	447	482	-	437	474	-	-	-	-	-	-	-
Stage 2	662	474	-	672	480	-	-	-	-	-	-	-

Approach	EB		WB		NB		SB	
HCM Control Delay, s	16.3		12.6		0		0	
HCM LOS	C		B					

Minor Lane/Major Mvmt	NBL	NBT	NBR	EBLn1	WBLn1	SBL	SBT	SBR
Capacity (veh/h)	961	-	-	345	485	949	-	-
HCM Lane V/C Ratio	-	-	-	0.08	0.02	0.001	-	-
HCM Control Delay (s)	0	-	-	16.3	12.6	8.8	-	-
HCM Lane LOS	A	-	-	C	B	A	-	-
HCM 95th %tile Q(veh)	0	-	-	0.3	0.1	0	-	-

Intersection						
Int Delay, s/veh	5.3					
Movement	WBL	WBR	NBT	NBR	SBL	SBT
Lane Configurations	↔		↑↓		↔	↑↑
Traffic Vol, veh/h	127	45	546	63	27	545
Future Vol, veh/h	127	45	546	63	27	545
Conflicting Peds, #/hr	0	0	0	0	0	0
Sign Control	Stop	Stop	Free	Free	Free	Free
RT Channelized	-	None	-	None	-	None
Storage Length	0	-	-	-	140	-
Veh in Median Storage, #	0	-	0	-	-	0
Grade, %	0	-	0	-	-	0
Peak Hour Factor	91	91	91	91	91	91
Heavy Vehicles, %	2	2	2	2	2	2
Mvmt Flow	140	49	600	69	30	599

Major/Minor	Minor1	Major1	Major2		
Conflicting Flow All	995	335	0	0	669
Stage 1	635	-	-	-	-
Stage 2	360	-	-	-	-
Critical Hdwy	6.84	6.94	-	-	4.14
Critical Hdwy Stg 1	5.84	-	-	-	-
Critical Hdwy Stg 2	5.84	-	-	-	-
Follow-up Hdwy	3.52	3.32	-	-	2.22
Pot Cap-1 Maneuver	242	661	-	-	917
Stage 1	490	-	-	-	-
Stage 2	677	-	-	-	-
Platoon blocked, %			-	-	-
Mov Cap-1 Maneuver	234	661	-	-	917
Mov Cap-2 Maneuver	234	-	-	-	-
Stage 1	490	-	-	-	-
Stage 2	655	-	-	-	-

Approach	WB	NB	SB
HCM Control Delay, s	40.3	0	0.4
HCM LOS	E		

Minor Lane/Major Mvmt	NBT	NBRWBLn1	SBL	SBT
Capacity (veh/h)	-	-	282	917
HCM Lane V/C Ratio	-	-	0.67	0.032
HCM Control Delay (s)	-	-	40.3	9.1
HCM Lane LOS	-	-	E	A
HCM 95th %tile Q(veh)	-	-	4.4	0.1

Heritage at Dalia Ranch
4: Imperial Ave & Neckel Rd

Opening Year 2028
Timing Plan: AM PEAK

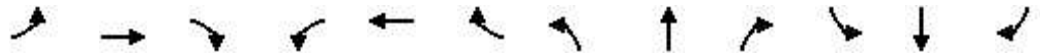

Movement	EBL	EBT	EBR	WBL	WBT	WBR	NBL	NBT	NBR	SBL	SBT	SBR
Lane Configurations		↕			↕		↕	↕		↕	↕	
Traffic Volume (veh/h)	36	46	13	232	68	87	9	493	96	24	612	33
Future Volume (veh/h)	36	46	13	232	68	87	9	493	96	24	612	33
Initial Q (Qb), veh	0	0	0	0	0	0	0	0	0	0	0	0
Ped-Bike Adj(A_pbT)	1.00		1.00	1.00		1.00	1.00		1.00	1.00		1.00
Parking Bus, Adj	1.00	1.00	1.00	1.00	1.00	1.00	1.00	1.00	1.00	1.00	1.00	1.00
Work Zone On Approach		No			No			No			No	
Adj Sat Flow, veh/h/ln	1870	1870	1870	1870	1870	1870	1870	1870	1870	1870	1870	1870
Adj Flow Rate, veh/h	40	51	14	255	75	96	10	542	105	26	673	36
Peak Hour Factor	0.91	0.91	0.91	0.91	0.91	0.91	0.91	0.91	0.91	0.91	0.91	0.91
Percent Heavy Veh, %	2	2	2	2	2	2	2	2	2	2	2	2
Cap, veh/h	55	70	19	295	87	111	23	737	142	53	910	49
Arrive On Green	0.08	0.08	0.08	0.28	0.28	0.28	0.01	0.25	0.25	0.03	0.27	0.27
Sat Flow, veh/h	683	871	239	1046	308	394	1781	2971	573	1781	3431	183
Grp Volume(v), veh/h	105	0	0	426	0	0	10	323	324	26	348	361
Grp Sat Flow(s),veh/h/ln	1793	0	0	1747	0	0	1781	1777	1767	1781	1777	1837
Q Serve(g_s), s	3.2	0.0	0.0	12.9	0.0	0.0	0.3	9.3	9.4	0.8	10.0	10.0
Cycle Q Clear(g_c), s	3.2	0.0	0.0	12.9	0.0	0.0	0.3	9.3	9.4	0.8	10.0	10.0
Prop In Lane	0.38		0.13	0.60		0.23	1.00		0.32	1.00		0.10
Lane Grp Cap(c), veh/h	143	0	0	492	0	0	23	441	439	53	471	487
V/C Ratio(X)	0.73	0.00	0.00	0.87	0.00	0.00	0.44	0.73	0.74	0.49	0.74	0.74
Avail Cap(c_a), veh/h	581	0	0	566	0	0	160	608	605	160	608	629
HCM Platoon Ratio	1.00	1.00	1.00	1.00	1.00	1.00	1.00	1.00	1.00	1.00	1.00	1.00
Upstream Filter(I)	1.00	0.00	0.00	1.00	0.00	0.00	1.00	1.00	1.00	1.00	1.00	1.00
Uniform Delay (d), s/veh	25.0	0.0	0.0	18.9	0.0	0.0	27.2	19.2	19.2	26.5	18.6	18.7
Incr Delay (d2), s/veh	7.0	0.0	0.0	12.0	0.0	0.0	12.5	2.9	3.1	6.9	3.5	3.4
Initial Q Delay(d3),s/veh	0.0	0.0	0.0	0.0	0.0	0.0	0.0	0.0	0.0	0.0	0.0	0.0
%ile BackOfQ(50%),veh/ln	1.5	0.0	0.0	6.3	0.0	0.0	0.2	3.8	3.8	0.4	4.1	4.3
Unsig. Movement Delay, s/veh												
LnGrp Delay(d),s/veh	32.0	0.0	0.0	30.9	0.0	0.0	39.7	22.1	22.3	33.4	22.1	22.1
LnGrp LOS	C	A	A	C	A	A	D	C	C	C	C	C
Approach Vol, veh/h		105			426			657				735
Approach Delay, s/veh		32.0			30.9			22.4				22.5
Approach LOS		C			C			C				C
Timer - Assigned Phs	1	2		4	5	6		8				
Phs Duration (G+Y+Rc), s	6.7	18.8		9.4	5.7	19.7		20.7				
Change Period (Y+Rc), s	5.0	5.0		5.0	5.0	5.0		5.0				
Max Green Setting (Gmax), s	5.0	19.0		18.0	5.0	19.0		18.0				
Max Q Clear Time (g_c+I1), s	2.8	11.4		5.2	2.3	12.0		14.9				
Green Ext Time (p_c), s	0.0	2.4		0.4	0.0	2.5		0.8				
Intersection Summary												
HCM 6th Ctrl Delay				24.9								
HCM 6th LOS				C								

Intersection												
Int Delay, s/veh	7.7											
Movement	EBL	EBT	EBR	WBL	WBT	WBR	NBL	NBT	NBR	SBL	SBT	SBR
Lane Configurations		↕			↕			↕			↕	
Traffic Vol, veh/h	4	44	24	64	47	0	8	7	45	1	2	1
Future Vol, veh/h	4	44	24	64	47	0	8	7	45	1	2	1
Conflicting Peds, #/hr	0	0	0	0	0	0	0	0	0	0	0	0
Sign Control	Stop	Stop	Stop	Stop	Stop	Stop	Free	Free	Free	Free	Free	Free
RT Channelized	-	-	None	-	-	None	-	-	None	-	-	None
Storage Length	-	-	-	-	-	-	-	-	-	-	-	-
Veh in Median Storage, #	-	0	-	-	0	-	-	0	-	-	0	-
Grade, %	-	0	-	-	0	-	-	0	-	-	0	-
Peak Hour Factor	79	79	79	79	79	79	79	79	79	79	79	79
Heavy Vehicles, %	2	2	2	2	2	2	2	2	2	2	2	2
Mvmt Flow	5	56	30	81	59	0	10	9	57	1	3	1

Major/Minor	Minor2		Minor1		Major1			Major2				
Conflicting Flow All	93	92	4	107	64	38	4	0	0	66	0	0
Stage 1	6	6	-	58	58	-	-	-	-	-	-	-
Stage 2	87	86	-	49	6	-	-	-	-	-	-	-
Critical Hdwy	7.12	6.52	6.22	7.12	6.52	6.22	4.12	-	-	4.12	-	-
Critical Hdwy Stg 1	6.12	5.52	-	6.12	5.52	-	-	-	-	-	-	-
Critical Hdwy Stg 2	6.12	5.52	-	6.12	5.52	-	-	-	-	-	-	-
Follow-up Hdwy	3.518	4.018	3.318	3.518	4.018	3.318	2.218	-	-	2.218	-	-
Pot Cap-1 Maneuver	891	798	1080	872	827	1034	1618	-	-	1536	-	-
Stage 1	1016	891	-	954	847	-	-	-	-	-	-	-
Stage 2	921	824	-	964	891	-	-	-	-	-	-	-
Platoon blocked, %								-	-	-	-	-
Mov Cap-1 Maneuver	838	792	1080	798	821	1034	1618	-	-	1536	-	-
Mov Cap-2 Maneuver	838	792	-	798	821	-	-	-	-	-	-	-
Stage 1	1010	890	-	948	842	-	-	-	-	-	-	-
Stage 2	851	819	-	877	890	-	-	-	-	-	-	-

Approach	EB		WB		NB		SB	
HCM Control Delay, s	9.6		10.4		1		1.8	
HCM LOS	A		B					

Minor Lane/Major Mvmt	NBL	NBT	NBR	EBLn1	WBLn1	SBL	SBT	SBR
Capacity (veh/h)	1618	-	-	872	808	1536	-	-
HCM Lane V/C Ratio	0.006	-	-	0.105	0.174	0.001	-	-
HCM Control Delay (s)	7.2	0	-	9.6	10.4	7.3	0	-
HCM Lane LOS	A	A	-	A	B	A	A	-
HCM 95th %tile Q(veh)	0	-	-	0.3	0.6	0	-	-

Heritage at Dalia Ranch
6: Imperial Ave & Worthington Rd/Barioni Blvd

Opening Year 2028
Timing Plan: AM PEAK

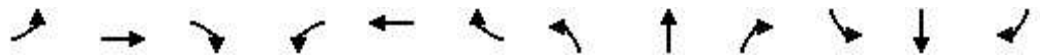

Movement	EBL	EBT	EBR	WBL	WBT	WBR	NBL	NBT	NBR	SBL	SBT	SBR
Lane Configurations		↕	↗		↕	↗	↗	↕↗		↗	↕↗	
Traffic Volume (veh/h)	83	145	227	58	141	83	99	537	54	42	796	84
Future Volume (veh/h)	83	145	227	58	141	83	99	537	54	42	796	84
Initial Q (Qb), veh	0	0	0	0	0	0	0	0	0	0	0	0
Ped-Bike Adj(A_pbT)	1.00		1.00	1.00		1.00	1.00		1.00	1.00		1.00
Parking Bus, Adj	1.00	1.00	1.00	1.00	1.00	1.00	1.00	1.00	1.00	1.00	1.00	1.00
Work Zone On Approach		No			No			No			No	
Adj Sat Flow, veh/h/ln	1870	1870	1870	1870	1870	1870	1870	1870	1870	1870	1870	1870
Adj Flow Rate, veh/h	93	163	255	65	158	93	111	603	61	47	894	94
Peak Hour Factor	0.89	0.89	0.89	0.89	0.89	0.89	0.89	0.89	0.89	0.89	0.89	0.89
Percent Heavy Veh, %	2	2	2	2	2	2	2	2	2	2	2	2
Cap, veh/h	134	234	317	85	207	251	130	999	101	77	899	94
Arrive On Green	0.20	0.20	0.20	0.16	0.16	0.16	0.07	0.31	0.31	0.04	0.28	0.28
Sat Flow, veh/h	667	1170	1585	537	1306	1585	1781	3259	329	1781	3245	341
Grp Volume(v), veh/h	256	0	255	223	0	93	111	328	336	47	490	498
Grp Sat Flow(s),veh/h/ln	1837	0	1585	1843	0	1585	1781	1777	1811	1781	1777	1809
Q Serve(g_s), s	8.9	0.0	10.5	7.9	0.0	3.6	4.2	10.8	10.8	1.8	18.9	18.9
Cycle Q Clear(g_c), s	8.9	0.0	10.5	7.9	0.0	3.6	4.2	10.8	10.8	1.8	18.9	18.9
Prop In Lane	0.36		1.00	0.29		1.00	1.00		0.18	1.00		0.19
Lane Grp Cap(c), veh/h	368	0	317	292	0	251	130	545	555	77	492	501
V/C Ratio(X)	0.70	0.00	0.80	0.76	0.00	0.37	0.86	0.60	0.60	0.61	0.99	0.99
Avail Cap(c_a), veh/h	482	0	416	484	0	416	130	545	555	130	492	501
HCM Platoon Ratio	1.00	1.00	1.00	1.00	1.00	1.00	1.00	1.00	1.00	1.00	1.00	1.00
Upstream Filter(I)	1.00	0.00	1.00	1.00	0.00	1.00	1.00	1.00	1.00	1.00	1.00	1.00
Uniform Delay (d), s/veh	25.5	0.0	26.2	27.6	0.0	25.8	31.4	20.2	20.2	32.3	24.8	24.8
Incr Delay (d2), s/veh	2.9	0.0	8.4	4.1	0.0	0.9	39.4	1.9	1.9	7.6	39.2	38.8
Initial Q Delay(d3),s/veh	0.0	0.0	0.0	0.0	0.0	0.0	0.0	0.0	0.0	0.0	0.0	0.0
%ile BackOfQ(50%),veh/ln	4.0	0.0	4.5	3.7	0.0	1.4	3.2	4.4	4.5	0.9	12.7	12.9
Unsig. Movement Delay, s/veh												
LnGrp Delay(d),s/veh	28.4	0.0	34.5	31.7	0.0	26.7	70.8	22.1	22.1	39.9	63.9	63.6
LnGrp LOS	C	A	C	C	A	C	E	C	C	D	E	E
Approach Vol, veh/h		511			316			775			1035	
Approach Delay, s/veh		31.5			30.3			29.1			62.7	
Approach LOS		C			C			C			E	
Timer - Assigned Phs	1	2		4	5	6		8				
Phs Duration (G+Y+Rc), s	8.0	26.0		18.7	10.0	24.0		15.9				
Change Period (Y+Rc), s	5.0	5.0		5.0	5.0	5.0		5.0				
Max Green Setting (Gmax), s	5.0	19.0		18.0	5.0	19.0		18.0				
Max Q Clear Time (g_c+I1), s	3.8	12.8		12.5	6.2	20.9		9.9				
Green Ext Time (p_c), s	0.0	2.1		1.2	0.0	0.0		1.0				
Intersection Summary												
HCM 6th Ctrl Delay				42.9								
HCM 6th LOS				D								

Intersection

Intersection Delay, s/veh25.7

Intersection LOS D

Movement	EBL	EBT	EBR	WBL	WBT	WBR	NBL	NBT	NBR	SBL	SBT	SBR
Lane Configurations		↔	↔		↔	↔		↔			↔	
Traffic Vol, veh/h	65	426	128	12	347	83	0	0	1	114	33	68
Future Vol, veh/h	65	426	128	12	347	83	0	0	1	114	33	68
Peak Hour Factor	0.92	0.92	0.92	0.92	0.92	0.92	0.92	0.92	0.92	0.92	0.92	0.92
Heavy Vehicles, %	2	2	2	2	2	2	2	2	2	2	2	2
Mvmt Flow	71	463	139	13	377	90	0	0	1	124	36	74
Number of Lanes	0	1	1	0	1	1	0	1	0	0	1	0

Approach	EB	WB	NB	SB
Opposing Approach	WB	EB	SB	NB
Opposing Lanes	2	2	1	1
Conflicting Approach Left	SB	NB	EB	WB
Conflicting Lanes Left	1	1	2	2
Conflicting Approach Right	NB	SB	WB	EB
Conflicting Lanes Right	1	1	2	2
HCM Control Delay	34.5	19	10	14.3
HCM LOS	D	C	A	B

Lane	NBLn1	EBLn1	EBLn2	WBLn1	WBLn2	SBLn1
Vol Left, %	0%	13%	0%	3%	0%	53%
Vol Thru, %	0%	87%	0%	97%	0%	15%
Vol Right, %	100%	0%	100%	0%	100%	32%
Sign Control	Stop	Stop	Stop	Stop	Stop	Stop
Traffic Vol by Lane	1	491	128	359	83	215
LT Vol	0	65	0	12	0	114
Through Vol	0	426	0	347	0	33
RT Vol	1	0	128	0	83	68
Lane Flow Rate	1	534	139	390	90	234
Geometry Grp	2	7	7	7	7	2
Degree of Util (X)	0.002	0.9	0.205	0.678	0.138	0.423
Departure Headway (Hd)	6.988	6.074	5.295	6.253	5.524	6.523
Convergence, Y/N	Yes	Yes	Yes	Yes	Yes	Yes
Cap	515	598	675	578	646	549
Service Time	4.988	3.828	3.05	4.016	3.287	4.588
HCM Lane V/C Ratio	0.002	0.893	0.206	0.675	0.139	0.426
HCM Control Delay	10	41	9.4	21.3	9.2	14.3
HCM Lane LOS	A	E	A	C	A	B
HCM 95th-tile Q	0	10.9	0.8	5.2	0.5	2.1

Heritage at Dalia Ranch
8: Imperial Ave & Aten Rd

Opening Year 2028
Timing Plan: AM PEAK



Movement	EBL	EBT	EBR	WBL	WBT	WBR	NBL	NBT	NBR	SBL	SBT	SBR
Lane Configurations												
Traffic Volume (veh/h)	208	362	67	140	321	151	65	399	72	152	815	426
Future Volume (veh/h)	208	362	67	140	321	151	65	399	72	152	815	426
Initial Q (Qb), veh	0	0	0	0	0	0	0	0	0	0	0	0
Ped-Bike Adj(A_pbT)	1.00		1.00	1.00		1.00	1.00		1.00	1.00		1.00
Parking Bus, Adj	1.00	1.00	1.00	1.00	1.00	1.00	1.00	1.00	1.00	1.00	1.00	1.00
Work Zone On Approach		No		No		No		No		No		No
Adj Sat Flow, veh/h/ln	1870	1870	1870	1870	1870	1870	1870	1870	1870	1870	1870	1870
Adj Flow Rate, veh/h	242	421	78	163	373	176	76	464	84	177	948	495
Peak Hour Factor	0.86	0.86	0.86	0.86	0.86	0.86	0.86	0.86	0.86	0.86	0.86	0.86
Percent Heavy Veh, %	2	2	2	2	2	2	2	2	2	2	2	2
Cap, veh/h	279	740	136	202	479	223	98	854	381	203	1064	475
Arrive On Green	0.16	0.25	0.25	0.11	0.20	0.20	0.06	0.24	0.24	0.11	0.30	0.30
Sat Flow, veh/h	1781	2997	551	1781	2355	1095	1781	3554	1585	1781	3554	1585
Grp Volume(v), veh/h	242	248	251	163	280	269	76	464	84	177	948	495
Grp Sat Flow(s),veh/h/ln	1781	1777	1771	1781	1777	1673	1781	1777	1585	1781	1777	1585
Q Serve(g_s), s	9.3	8.6	8.7	6.3	10.4	10.7	3.0	8.0	3.0	6.9	17.9	21.0
Cycle Q Clear(g_c), s	9.3	8.6	8.7	6.3	10.4	10.7	3.0	8.0	3.0	6.9	17.9	21.0
Prop In Lane	1.00		0.31	1.00		0.65	1.00		1.00	1.00		1.00
Lane Grp Cap(c), veh/h	279	439	438	202	362	341	98	854	381	203	1064	475
V/C Ratio(X)	0.87	0.57	0.57	0.81	0.77	0.79	0.77	0.54	0.22	0.87	0.89	1.04
Avail Cap(c_a), veh/h	279	507	505	229	456	429	127	912	407	203	1064	475
HCM Platoon Ratio	1.00	1.00	1.00	1.00	1.00	1.00	1.00	1.00	1.00	1.00	1.00	1.00
Upstream Filter(l)	1.00	1.00	1.00	1.00	1.00	1.00	1.00	1.00	1.00	1.00	1.00	1.00
Uniform Delay (d), s/veh	28.9	23.1	23.2	30.3	26.4	26.5	32.7	23.3	21.4	30.6	23.5	24.6
Incr Delay (d2), s/veh	23.7	1.1	1.2	17.2	6.3	7.6	19.6	0.6	0.3	31.1	9.6	53.0
Initial Q Delay(d3),s/veh	0.0	0.0	0.0	0.0	0.0	0.0	0.0	0.0	0.0	0.0	0.0	0.0
%ile BackOfQ(50%),veh/ln	5.6	3.5	3.6	3.5	4.8	4.8	1.8	3.2	1.1	4.6	8.4	14.3
Unsig. Movement Delay, s/veh												
LnGrp Delay(d),s/veh	52.5	24.3	24.3	47.5	32.7	34.1	52.3	23.8	21.7	61.7	33.1	77.6
LnGrp LOS	D	C	C	D	C	C	D	C	C	E	C	F
Approach Vol, veh/h		741			712			624			1620	
Approach Delay, s/veh		33.5			36.6			27.0			49.8	
Approach LOS		C			D			C			D	
Timer - Assigned Phs	1	2	3	4	5	6	7	8				
Phs Duration (G+Y+Rc), s	13.0	21.9	12.9	22.3	8.9	26.0	16.0	19.3				
Change Period (Y+Rc), s	5.0	5.0	5.0	5.0	5.0	5.0	5.0	5.0				
Max Green Setting (Gmax), s	18.0	18.0	9.0	20.0	5.0	21.0	11.0	18.0				
Max Q Clear Time (g_c+1/3), s	10.0	10.0	8.3	10.7	5.0	23.0	11.3	12.7				
Green Ext Time (p_c), s	0.0	2.1	0.0	2.1	0.0	0.0	0.0	1.6				
Intersection Summary												
HCM 6th Ctrl Delay											40.2	
HCM 6th LOS											D	

Heritage at Dalia Ranch
1: SR-86 & Keystone Rd

Opening Year 2028
Timing Plan: PM PEAK



Movement	EBL	EBT	EBR	WBL	WBT	WBR	NBL	NBT	NBR	SBL	SBT	SBR
Lane Configurations		↔			↔		↗	↕	↗	↗	↕	↗
Traffic Volume (veh/h)	44	13	21	35	29	40	11	591	28	56	632	36
Future Volume (veh/h)	44	13	21	35	29	40	11	591	28	56	632	36
Initial Q (Qb), veh	0	0	0	0	0	0	0	0	0	0	0	0
Ped-Bike Adj(A_pbT)	1.00		1.00	1.00		1.00	1.00		1.00	1.00		1.00
Parking Bus, Adj	1.00	1.00	1.00	1.00	1.00	1.00	1.00	1.00	1.00	1.00	1.00	1.00
Work Zone On Approach		No			No			No			No	
Adj Sat Flow, veh/h/ln	1870	1870	1870	1870	1870	1870	1870	1870	1870	1870	1870	1870
Adj Flow Rate, veh/h	49	15	24	39	33	45	12	664	31	63	710	40
Peak Hour Factor	0.89	0.89	0.89	0.89	0.89	0.89	0.89	0.89	0.89	0.89	0.89	0.89
Percent Heavy Veh, %	2	2	2	2	2	2	2	2	2	2	2	2
Cap, veh/h	276	52	58	208	73	83	28	1200	535	119	1382	616
Arrive On Green	0.13	0.13	0.13	0.13	0.13	0.13	0.02	0.34	0.34	0.07	0.39	0.39
Sat Flow, veh/h	785	400	445	452	561	633	1781	3554	1585	1781	3554	1585
Grp Volume(v), veh/h	88	0	0	117	0	0	12	664	31	63	710	40
Grp Sat Flow(s),veh/h/ln	1630	0	0	1647	0	0	1781	1777	1585	1781	1777	1585
Q Serve(g_s), s	0.0	0.0	0.0	0.6	0.0	0.0	0.2	4.9	0.4	1.1	4.9	0.5
Cycle Q Clear(g_c), s	1.4	0.0	0.0	2.0	0.0	0.0	0.2	4.9	0.4	1.1	4.9	0.5
Prop In Lane	0.56		0.27	0.33		0.38	1.00		1.00	1.00		1.00
Lane Grp Cap(c), veh/h	386	0	0	363	0	0	28	1200	535	119	1382	616
V/C Ratio(X)	0.23	0.00	0.00	0.32	0.00	0.00	0.43	0.55	0.06	0.53	0.51	0.06
Avail Cap(c_a), veh/h	1011	0	0	1035	0	0	276	2314	1032	331	2424	1081
HCM Platoon Ratio	1.00	1.00	1.00	1.00	1.00	1.00	1.00	1.00	1.00	1.00	1.00	1.00
Upstream Filter(l)	1.00	0.00	0.00	1.00	0.00	0.00	1.00	1.00	1.00	1.00	1.00	1.00
Uniform Delay (d), s/veh	12.8	0.0	0.0	13.1	0.0	0.0	15.7	8.7	7.2	14.6	7.5	6.2
Incr Delay (d2), s/veh	0.3	0.0	0.0	0.5	0.0	0.0	9.9	0.4	0.0	3.6	0.3	0.0
Initial Q Delay(d3),s/veh	0.0	0.0	0.0	0.0	0.0	0.0	0.0	0.0	0.0	0.0	0.0	0.0
%ile BackOfQ(50%),veh/ln	0.5	0.0	0.0	0.7	0.0	0.0	0.1	1.3	0.1	0.5	1.2	0.1
Unsig. Movement Delay, s/veh												
LnGrp Delay(d),s/veh	13.1	0.0	0.0	13.6	0.0	0.0	25.6	9.1	7.3	18.2	7.8	6.2
LnGrp LOS	B	A	A	B	A	A	C	A	A	B	A	A
Approach Vol, veh/h		88			117			707			813	
Approach Delay, s/veh		13.1			13.6			9.3			8.5	
Approach LOS		B			B			A			A	
Timer - Assigned Phs	1	2		4	5	6		8				
Phs Duration (G+Y+Rc), s	7.2	15.9		9.2	5.5	17.5		9.2				
Change Period (Y+Rc), s	5.0	5.0		5.0	5.0	5.0		5.0				
Max Green Setting (Gmax), s	6.0	21.0		18.0	5.0	22.0		18.0				
Max Q Clear Time (g_c+I1), s	3.1	6.9		3.4	2.2	6.9		4.0				
Green Ext Time (p_c), s	0.0	4.0		0.3	0.0	4.5		0.5				
Intersection Summary												
HCM 6th Ctrl Delay				9.4								
HCM 6th LOS				A								

Intersection												
Int Delay, s/veh	0.4											
Movement	EBL	EBT	EBR	WBL	WBT	WBR	NBL	NBT	NBR	SBL	SBT	SBR
Lane Configurations		↕			↕		↕	↕		↕	↕	
Traffic Vol, veh/h	7	4	0	8	0	6	1	632	8	7	670	19
Future Vol, veh/h	7	4	0	8	0	6	1	632	8	7	670	19
Conflicting Peds, #/hr	0	0	0	0	0	0	0	0	0	0	0	0
Sign Control	Stop	Stop	Stop	Stop	Stop	Stop	Free	Free	Free	Free	Free	Free
RT Channelized	-	-	None	-	-	None	-	-	None	-	-	None
Storage Length	-	-	-	-	-	-	50	-	-	50	-	-
Veh in Median Storage, #	-	1	-	-	1	-	-	0	-	-	0	-
Grade, %	-	0	-	-	0	-	-	0	-	-	0	-
Peak Hour Factor	92	92	92	92	92	92	92	92	92	92	92	92
Heavy Vehicles, %	2	2	2	2	2	2	2	2	2	2	2	2
Mvmt Flow	8	4	0	9	0	7	1	687	9	8	728	21

Major/Minor	Minor2		Minor1		Major1		Major2					
Conflicting Flow All	1101	1453	375	1076	1459	348	749	0	0	696	0	0
Stage 1	755	755	-	694	694	-	-	-	-	-	-	-
Stage 2	346	698	-	382	765	-	-	-	-	-	-	-
Critical Hdwy	7.54	6.54	6.94	7.54	6.54	6.94	4.14	-	-	4.14	-	-
Critical Hdwy Stg 1	6.54	5.54	-	6.54	5.54	-	-	-	-	-	-	-
Critical Hdwy Stg 2	6.54	5.54	-	6.54	5.54	-	-	-	-	-	-	-
Follow-up Hdwy	3.52	4.02	3.32	3.52	4.02	3.32	2.22	-	-	2.22	-	-
Pot Cap-1 Maneuver	166	129	623	174	128	648	856	-	-	896	-	-
Stage 1	367	415	-	399	442	-	-	-	-	-	-	-
Stage 2	643	440	-	612	410	-	-	-	-	-	-	-
Platoon blocked, %								-	-	-	-	-
Mov Cap-1 Maneuver	163	128	623	170	127	648	856	-	-	896	-	-
Mov Cap-2 Maneuver	278	251	-	291	251	-	-	-	-	-	-	-
Stage 1	367	411	-	399	442	-	-	-	-	-	-	-
Stage 2	636	440	-	600	406	-	-	-	-	-	-	-

Approach	EB		WB		NB		SB	
HCM Control Delay, s	19.1		14.8		0		0.1	
HCM LOS	C		B					

Minor Lane/Major Mvmt	NBL	NBT	NBR	EBLn1	WBLn1	SBL	SBT	SBR
Capacity (veh/h)	856	-	-	268	381	896	-	-
HCM Lane V/C Ratio	0.001	-	-	0.045	0.04	0.008	-	-
HCM Control Delay (s)	9.2	-	-	19.1	14.8	9.1	-	-
HCM Lane LOS	A	-	-	C	B	A	-	-
HCM 95th %tile Q(veh)	0	-	-	0.1	0.1	0	-	-

Intersection						
Int Delay, s/veh	2.2					
Movement	WBL	WBR	NBT	NBR	SBL	SBT
Lane Configurations	TT		TT		T	TT
Traffic Vol, veh/h	58	23	621	96	53	611
Future Vol, veh/h	58	23	621	96	53	611
Conflicting Peds, #/hr	0	0	0	0	0	0
Sign Control	Stop	Stop	Free	Free	Free	Free
RT Channelized	-	None	-	None	-	None
Storage Length	0	-	-	-	140	-
Veh in Median Storage, #	0	-	0	-	-	0
Grade, %	0	-	0	-	-	0
Peak Hour Factor	91	91	91	91	91	91
Heavy Vehicles, %	2	2	2	2	2	2
Mvmt Flow	64	25	682	105	58	671

Major/Minor	Minor1	Major1	Major2		
Conflicting Flow All	1187	394	0	0	787
Stage 1	735	-	-	-	-
Stage 2	452	-	-	-	-
Critical Hdwy	6.84	6.94	-	-	4.14
Critical Hdwy Stg 1	5.84	-	-	-	-
Critical Hdwy Stg 2	5.84	-	-	-	-
Follow-up Hdwy	3.52	3.32	-	-	2.22
Pot Cap-1 Maneuver	181	605	-	-	828
Stage 1	435	-	-	-	-
Stage 2	608	-	-	-	-
Platoon blocked, %					
Mov Cap-1 Maneuver	168	605	-	-	828
Mov Cap-2 Maneuver	168	-	-	-	-
Stage 1	435	-	-	-	-
Stage 2	565	-	-	-	-

Approach	WB	NB	SB
HCM Control Delay, s	34	0	0.8
HCM LOS	D		

Minor Lane/Major Mvmt	NBT	NBRWBLn1	SBL	SBT
Capacity (veh/h)	-	-	211	828
HCM Lane V/C Ratio	-	-	0.422	0.07
HCM Control Delay (s)	-	-	34	9.7
HCM Lane LOS	-	-	D	A
HCM 95th %tile Q(veh)	-	-	1.9	0.2

Heritage at Dalia Ranch
4: Imperial Ave & Neckel Rd

Opening Year 2028
Timing Plan: PM PEAK

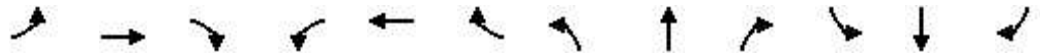

Movement	EBL	EBT	EBR	WBL	WBT	WBR	NBL	NBT	NBR	SBL	SBT	SBR
Lane Configurations		↕			↕		↕	↕		↕	↕	
Traffic Volume (veh/h)	13	28	4	141	21	68	12	659	180	61	568	30
Future Volume (veh/h)	13	28	4	141	21	68	12	659	180	61	568	30
Initial Q (Qb), veh	0	0	0	0	0	0	0	0	0	0	0	0
Ped-Bike Adj(A_pbT)	1.00		1.00	1.00		1.00	1.00		1.00	1.00		1.00
Parking Bus, Adj	1.00	1.00	1.00	1.00	1.00	1.00	1.00	1.00	1.00	1.00	1.00	1.00
Work Zone On Approach		No			No			No			No	
Adj Sat Flow, veh/h/ln	1870	1870	1870	1870	1870	1870	1870	1870	1870	1870	1870	1870
Adj Flow Rate, veh/h	14	30	4	153	23	74	13	716	196	66	617	33
Peak Hour Factor	0.92	0.92	0.92	0.92	0.92	0.92	0.92	0.92	0.92	0.92	0.92	0.92
Percent Heavy Veh, %	2	2	2	2	2	2	2	2	2	2	2	2
Cap, veh/h	25	55	7	199	30	96	29	886	243	105	1249	67
Arrive On Green	0.05	0.05	0.05	0.19	0.19	0.19	0.02	0.32	0.32	0.06	0.36	0.36
Sat Flow, veh/h	530	1135	151	1056	159	511	1781	2757	755	1781	3431	183
Grp Volume(v), veh/h	48	0	0	250	0	0	13	461	451	66	319	331
Grp Sat Flow(s),veh/h/ln	1817	0	0	1726	0	0	1781	1777	1735	1781	1777	1837
Q Serve(g_s), s	1.3	0.0	0.0	7.2	0.0	0.0	0.4	12.4	12.4	1.9	7.3	7.3
Cycle Q Clear(g_c), s	1.3	0.0	0.0	7.2	0.0	0.0	0.4	12.4	12.4	1.9	7.3	7.3
Prop In Lane	0.29		0.08	0.61		0.30	1.00		0.44	1.00		0.10
Lane Grp Cap(c), veh/h	87	0	0	325	0	0	29	571	558	105	647	669
V/C Ratio(X)	0.55	0.00	0.00	0.77	0.00	0.00	0.44	0.81	0.81	0.63	0.49	0.49
Avail Cap(c_a), veh/h	626	0	0	595	0	0	171	647	631	171	647	669
HCM Platoon Ratio	1.00	1.00	1.00	1.00	1.00	1.00	1.00	1.00	1.00	1.00	1.00	1.00
Upstream Filter(l)	1.00	0.00	0.00	1.00	0.00	0.00	1.00	1.00	1.00	1.00	1.00	1.00
Uniform Delay (d), s/veh	24.3	0.0	0.0	20.1	0.0	0.0	25.4	16.2	16.2	24.0	12.9	12.9
Incr Delay (d2), s/veh	5.3	0.0	0.0	3.8	0.0	0.0	10.2	6.8	6.9	6.0	0.6	0.6
Initial Q Delay(d3),s/veh	0.0	0.0	0.0	0.0	0.0	0.0	0.0	0.0	0.0	0.0	0.0	0.0
%ile BackOfQ(50%),veh/ln	0.7	0.0	0.0	2.9	0.0	0.0	0.2	5.4	5.3	0.9	2.6	2.7
Unsig. Movement Delay, s/veh												
LnGrp Delay(d),s/veh	29.6	0.0	0.0	23.9	0.0	0.0	35.6	23.0	23.2	30.0	13.5	13.4
LnGrp LOS	C	A	A	C	A	A	D	C	C	C	B	B
Approach Vol, veh/h		48			250			925			716	
Approach Delay, s/veh		29.6			23.9			23.3			15.0	
Approach LOS		C			C			C			B	
Timer - Assigned Phs	1	2		4	5	6		8				
Phs Duration (G+Y+Rc), s	8.1	21.8		7.5	5.9	24.0		14.8				
Change Period (Y+Rc), s	5.0	5.0		5.0	5.0	5.0		5.0				
Max Green Setting (Gmax), s	5.0	19.0		18.0	5.0	19.0		18.0				
Max Q Clear Time (g_c+I1), s	3.9	14.4		3.3	2.4	9.3		9.2				
Green Ext Time (p_c), s	0.0	2.3		0.1	0.0	2.8		0.9				
Intersection Summary												
HCM 6th Ctrl Delay				20.4								
HCM 6th LOS				C								

Intersection												
Int Delay, s/veh	7.7											
Movement	EBL	EBT	EBR	WBL	WBT	WBR	NBL	NBT	NBR	SBL	SBT	SBR
Lane Configurations		↕			↕			↕			↕	
Traffic Vol, veh/h	2	41	9	24	47	1	6	7	11	0	6	8
Future Vol, veh/h	2	41	9	24	47	1	6	7	11	0	6	8
Conflicting Peds, #/hr	0	0	0	0	0	0	0	0	0	0	0	0
Sign Control	Stop	Stop	Stop	Stop	Stop	Stop	Free	Free	Free	Free	Free	Free
RT Channelized	-	-	None	-	-	None	-	-	None	-	-	None
Storage Length	-	-	-	-	-	-	-	-	-	-	-	-
Veh in Median Storage, #	-	0	-	-	0	-	-	0	-	-	0	-
Grade, %	-	0	-	-	0	-	-	0	-	-	0	-
Peak Hour Factor	79	79	79	79	79	79	79	79	79	79	79	79
Heavy Vehicles, %	2	2	2	2	2	2	2	2	2	2	2	2
Mvmt Flow	3	52	11	30	59	1	8	9	14	0	8	10

Major/Minor	Minor2		Minor1		Major1			Major2				
Conflicting Flow All	75	52	13	77	50	16	18	0	0	23	0	0
Stage 1	13	13	-	32	32	-	-	-	-	-	-	-
Stage 2	62	39	-	45	18	-	-	-	-	-	-	-
Critical Hdwy	7.12	6.52	6.22	7.12	6.52	6.22	4.12	-	-	4.12	-	-
Critical Hdwy Stg 1	6.12	5.52	-	6.12	5.52	-	-	-	-	-	-	-
Critical Hdwy Stg 2	6.12	5.52	-	6.12	5.52	-	-	-	-	-	-	-
Follow-up Hdwy	3.518	4.018	3.318	3.518	4.018	3.318	2.218	-	-	2.218	-	-
Pot Cap-1 Maneuver	915	839	1067	912	841	1063	1599	-	-	1592	-	-
Stage 1	1007	885	-	984	868	-	-	-	-	-	-	-
Stage 2	949	862	-	969	880	-	-	-	-	-	-	-
Platoon blocked, %								-	-	-	-	-
Mov Cap-1 Maneuver	861	835	1067	856	837	1063	1599	-	-	1592	-	-
Mov Cap-2 Maneuver	861	835	-	856	837	-	-	-	-	-	-	-
Stage 1	1002	885	-	979	864	-	-	-	-	-	-	-
Stage 2	878	858	-	902	880	-	-	-	-	-	-	-

Approach	EB		WB		NB		SB	
HCM Control Delay, s	9.5		9.8		1.8		0	
HCM LOS	A		A					

Minor Lane/Major Mvmt	NBL	NBT	NBR	EBLn1	WBLn1	SBL	SBT	SBR
Capacity (veh/h)	1599	-	-	869	846	1592	-	-
HCM Lane V/C Ratio	0.005	-	-	0.076	0.108	-	-	-
HCM Control Delay (s)	7.3	0	-	9.5	9.8	0	-	-
HCM Lane LOS	A	A	-	A	A	A	-	-
HCM 95th %tile Q(veh)	0	-	-	0.2	0.4	0	-	-

Heritage at Dalia Ranch
6: Imperial Ave & Worthington Rd/Barioni Blvd

Opening Year 2028
Timing Plan: PM PEAK



Movement	EBL	EBT	EBR	WBL	WBT	WBR	NBL	NBT	NBR	SBL	SBT	SBR
Lane Configurations		↕	↗		↕	↗	↖	↕↗		↖	↕↗	
Traffic Volume (veh/h)	78	79	112	58	120	55	120	843	15	29	711	82
Future Volume (veh/h)	78	79	112	58	120	55	120	843	15	29	711	82
Initial Q (Qb), veh	0	0	0	0	0	0	0	0	0	0	0	0
Ped-Bike Adj(A_pbT)	1.00		1.00	1.00		1.00	1.00		1.00	1.00		1.00
Parking Bus, Adj	1.00	1.00	1.00	1.00	1.00	1.00	1.00	1.00	1.00	1.00	1.00	1.00
Work Zone On Approach		No			No			No			No	
Adj Sat Flow, veh/h/ln	1870	1870	1870	1870	1870	1870	1870	1870	1870	1870	1870	1870
Adj Flow Rate, veh/h	86	87	123	64	132	60	132	926	16	32	781	90
Peak Hour Factor	0.91	0.91	0.91	0.91	0.91	0.91	0.91	0.91	0.91	0.91	0.91	0.91
Percent Heavy Veh, %	2	2	2	2	2	2	2	2	2	2	2	2
Cap, veh/h	126	128	221	89	183	234	168	1228	21	61	912	105
Arrive On Green	0.14	0.14	0.14	0.15	0.15	0.15	0.09	0.34	0.34	0.03	0.28	0.28
Sat Flow, veh/h	907	918	1585	601	1239	1585	1781	3574	62	1781	3211	370
Grp Volume(v), veh/h	173	0	123	196	0	60	132	460	482	32	432	439
Grp Sat Flow(s),veh/h/ln	1825	0	1585	1840	0	1585	1781	1777	1859	1781	1777	1804
Q Serve(g_s), s	5.4	0.0	4.3	6.1	0.0	2.0	4.3	13.7	13.7	1.1	13.7	13.7
Cycle Q Clear(g_c), s	5.4	0.0	4.3	6.1	0.0	2.0	4.3	13.7	13.7	1.1	13.7	13.7
Prop In Lane	0.50		1.00	0.33		1.00	1.00		0.03	1.00		0.21
Lane Grp Cap(c), veh/h	254	0	221	272	0	234	168	611	639	61	505	512
V/C Ratio(X)	0.68	0.00	0.56	0.72	0.00	0.26	0.79	0.75	0.75	0.52	0.86	0.86
Avail Cap(c_a), veh/h	550	0	478	555	0	478	179	611	639	149	536	544
HCM Platoon Ratio	1.00	1.00	1.00	1.00	1.00	1.00	1.00	1.00	1.00	1.00	1.00	1.00
Upstream Filter(l)	1.00	0.00	1.00	1.00	0.00	1.00	1.00	1.00	1.00	1.00	1.00	1.00
Uniform Delay (d), s/veh	24.4	0.0	24.0	24.3	0.0	22.5	26.4	17.4	17.4	28.3	20.2	20.2
Incr Delay (d2), s/veh	3.2	0.0	2.2	3.6	0.0	0.6	19.4	5.3	5.1	6.7	12.4	12.3
Initial Q Delay(d3),s/veh	0.0	0.0	0.0	0.0	0.0	0.0	0.0	0.0	0.0	0.0	0.0	0.0
%ile BackOfQ(50%),veh/ln	2.4	0.0	1.6	2.7	0.0	0.7	2.6	5.9	6.1	0.5	6.9	7.0
Unsig. Movement Delay, s/veh												
LnGrp Delay(d),s/veh	27.6	0.0	26.2	27.9	0.0	23.1	45.9	22.6	22.4	35.0	32.6	32.5
LnGrp LOS	C	A	C	C	A	C	D	C	C	D	C	C
Approach Vol, veh/h		296			256			1074			903	
Approach Delay, s/veh		27.0			26.8			25.4			32.7	
Approach LOS		C			C			C			C	
Timer - Assigned Phs	1	2		4	5	6		8				
Phs Duration (G+Y+Rc), s	7.1	25.5		13.3	10.6	21.9		13.8				
Change Period (Y+Rc), s	5.0	5.0		5.0	5.0	5.0		5.0				
Max Green Setting (Gmax), s	5.0	19.0		18.0	6.0	18.0		18.0				
Max Q Clear Time (g_c+I1), s	3.1	15.7		7.4	6.3	15.7		8.1				
Green Ext Time (p_c), s	0.0	1.8		1.0	0.0	1.2		0.9				
Intersection Summary												
HCM 6th Ctrl Delay				28.3								
HCM 6th LOS				C								

Intersection												
Intersection Delay, s/veh	11.7											
Intersection LOS	B											

Movement	EBL	EBT	EBR	WBL	WBT	WBR	NBL	NBT	NBR	SBL	SBT	SBR
Lane Configurations		↔	↔		↔	↔		↔			↔	
Traffic Vol, veh/h	28	227	35	29	245	36	1	0	0	40	6	25
Future Vol, veh/h	28	227	35	29	245	36	1	0	0	40	6	25
Peak Hour Factor	0.80	0.80	0.80	0.80	0.80	0.80	0.80	0.80	0.80	0.80	0.80	0.80
Heavy Vehicles, %	2	2	2	2	2	2	2	2	2	2	2	2
Mvmt Flow	35	284	44	36	306	45	1	0	0	50	8	31
Number of Lanes	0	1	1	0	1	1	0	1	0	0	1	0

Approach	EB	WB	NB	SB
Opposing Approach	WB	EB	SB	NB
Opposing Lanes	2	2	1	1
Conflicting Approach Left	SB	NB	EB	WB
Conflicting Lanes Left	1	1	2	2
Conflicting Approach Right	NB	SB	WB	EB
Conflicting Lanes Right	1	1	2	2
HCM Control Delay	11.7	12.2	9.1	9.5
HCM LOS	B	B	A	A

Lane	NBLn1	EBLn1	EBLn2	WBLn1	WBLn2	SBLn1
Vol Left, %	100%	11%	0%	11%	0%	56%
Vol Thru, %	0%	89%	0%	89%	0%	8%
Vol Right, %	0%	0%	100%	0%	100%	35%
Sign Control	Stop	Stop	Stop	Stop	Stop	Stop
Traffic Vol by Lane	1	255	35	274	36	71
LT Vol	1	28	0	29	0	40
Through Vol	0	227	0	245	0	6
RT Vol	0	0	35	0	36	25
Lane Flow Rate	1	319	44	342	45	89
Geometry Grp	2	7	7	7	7	2
Degree of Util (X)	0.002	0.458	0.054	0.49	0.055	0.137
Departure Headway (Hd)	6.024	5.171	4.411	5.148	4.391	5.54
Convergence, Y/N	Yes	Yes	Yes	Yes	Yes	Yes
Cap	589	695	808	699	812	643
Service Time	4.115	2.919	2.159	2.895	2.138	3.605
HCM Lane V/C Ratio	0.002	0.459	0.054	0.489	0.055	0.138
HCM Control Delay	9.1	12.3	7.4	12.8	7.4	9.5
HCM Lane LOS	A	B	A	B	A	A
HCM 95th-tile Q	0	2.4	0.2	2.7	0.2	0.5

Heritage at Dalia Ranch
8: Imperial Ave & Aten Rd

Opening Year 2028
Timing Plan: PM PEAK



Movement	EBL	EBT	EBR	WBL	WBT	WBR	NBL	NBT	NBR	SBL	SBT	SBR
Lane Configurations												
Traffic Volume (veh/h)	229	295	73	191	309	131	84	814	160	120	636	239
Future Volume (veh/h)	229	295	73	191	309	131	84	814	160	120	636	239
Initial Q (Qb), veh	0	0	0	0	0	0	0	0	0	0	0	0
Ped-Bike Adj(A_pbT)	1.00		1.00	1.00		1.00	1.00		1.00	1.00		1.00
Parking Bus, Adj	1.00	1.00	1.00	1.00	1.00	1.00	1.00	1.00	1.00	1.00	1.00	1.00
Work Zone On Approach		No		No		No		No		No		No
Adj Sat Flow, veh/h/ln	1870	1870	1870	1870	1870	1870	1870	1870	1870	1870	1870	1870
Adj Flow Rate, veh/h	244	314	78	203	329	139	89	866	170	128	677	254
Peak Hour Factor	0.94	0.94	0.94	0.94	0.94	0.94	0.94	0.94	0.94	0.94	0.94	0.94
Percent Heavy Veh, %	2	2	2	2	2	2	2	2	2	2	2	2
Cap, veh/h	287	581	142	246	448	186	114	970	432	162	1065	475
Arrive On Green	0.16	0.21	0.21	0.14	0.18	0.18	0.06	0.27	0.27	0.09	0.30	0.30
Sat Flow, veh/h	1781	2830	693	1781	2449	1015	1781	3554	1585	1781	3554	1585
Grp Volume(v), veh/h	244	195	197	203	237	231	89	866	170	128	677	254
Grp Sat Flow(s),veh/h/ln	1781	1777	1746	1781	1777	1688	1781	1777	1585	1781	1777	1585
Q Serve(g_s), s	9.1	6.7	6.9	7.6	8.6	8.9	3.4	16.0	6.0	4.8	11.3	9.1
Cycle Q Clear(g_c), s	9.1	6.7	6.9	7.6	8.6	8.9	3.4	16.0	6.0	4.8	11.3	9.1
Prop In Lane	1.00		0.40	1.00		0.60	1.00		1.00	1.00		1.00
Lane Grp Cap(c), veh/h	287	365	358	246	325	308	114	970	432	162	1065	475
V/C Ratio(X)	0.85	0.54	0.55	0.82	0.73	0.75	0.78	0.89	0.39	0.79	0.64	0.53
Avail Cap(c_a), veh/h	287	468	460	287	468	444	156	988	441	182	1065	475
HCM Platoon Ratio	1.00	1.00	1.00	1.00	1.00	1.00	1.00	1.00	1.00	1.00	1.00	1.00
Upstream Filter(l)	1.00	1.00	1.00	1.00	1.00	1.00	1.00	1.00	1.00	1.00	1.00	1.00
Uniform Delay (d), s/veh	27.9	24.2	24.3	28.6	26.3	26.4	31.5	23.9	20.2	30.4	20.7	20.0
Incr Delay (d2), s/veh	21.0	1.2	1.3	15.5	3.3	4.2	15.6	10.3	0.6	18.6	1.3	1.2
Initial Q Delay(d3),s/veh	0.0	0.0	0.0	0.0	0.0	0.0	0.0	0.0	0.0	0.0	0.0	0.0
%ile BackOfQ(50%),veh/ln	5.4	2.8	2.8	4.1	3.8	3.7	1.9	7.6	2.1	2.8	4.5	3.3
Unsig. Movement Delay, s/veh												
LnGrp Delay(d),s/veh	48.9	25.5	25.6	44.2	29.6	30.6	47.1	34.2	20.8	49.0	22.0	21.1
LnGrp LOS	D	C	C	D	C	C	D	C	C	D	C	C
Approach Vol, veh/h		636			671			1125			1059	
Approach Delay, s/veh		34.5			34.4			33.2			25.0	
Approach LOS		C			C			C			C	
Timer - Assigned Phs	1	2	3	4	5	6	7	8				
Phs Duration (G+Y+Rc), s	11.2	23.6	14.5	19.0	9.4	25.5	16.0	17.5				
Change Period (Y+Rc), s	5.0	5.0	5.0	5.0	5.0	5.0	5.0	5.0				
Max Green Setting (Gmax), s	19.0	11.0	18.0	6.0	20.0	11.0	18.0					
Max Q Clear Time (g_c+1/3), s	18.0	9.6	8.9	5.4	13.3	11.1	10.9					
Green Ext Time (p_c), s	0.0	0.6	0.1	1.5	0.0	3.0	0.0	1.6				
Intersection Summary												
HCM 6th Ctrl Delay											31.2	
HCM 6th LOS											C	

Heritage at Dalia Ranch
1: SR-86 & Keystone Rd

Opening Year 2028 + P1-4 Proj
Timing Plan: AM PEAK

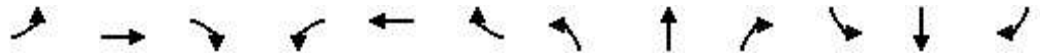

Movement	EBL	EBT	EBR	WBL	WBT	WBR	NBL	NBT	NBR	SBL	SBT	SBR
Lane Configurations		↕			↕		↗	↕	↗	↗	↕	↗
Traffic Volume (veh/h)	35	35	12	20	25	45	20	601	53	48	620	40
Future Volume (veh/h)	35	35	12	20	25	45	20	601	53	48	620	40
Initial Q (Qb), veh	0	0	0	0	0	0	0	0	0	0	0	0
Ped-Bike Adj(A_pbT)	1.00		1.00	1.00		1.00	1.00		1.00	1.00		1.00
Parking Bus, Adj	1.00	1.00	1.00	1.00	1.00	1.00	1.00	1.00	1.00	1.00	1.00	1.00
Work Zone On Approach		No			No			No			No	
Adj Sat Flow, veh/h/ln	1870	1870	1870	1870	1870	1870	1870	1870	1870	1870	1870	1870
Adj Flow Rate, veh/h	39	39	13	22	28	50	22	668	59	53	689	44
Peak Hour Factor	0.90	0.90	0.90	0.90	0.90	0.90	0.90	0.90	0.90	0.90	0.90	0.90
Percent Heavy Veh, %	2	2	2	2	2	2	2	2	2	2	2	2
Cap, veh/h	241	108	31	175	72	107	50	1184	528	105	1295	578
Arrive On Green	0.13	0.13	0.13	0.13	0.13	0.13	0.03	0.33	0.33	0.06	0.36	0.36
Sat Flow, veh/h	595	834	238	271	554	825	1781	3554	1585	1781	3554	1585
Grp Volume(v), veh/h	91	0	0	100	0	0	22	668	59	53	689	44
Grp Sat Flow(s),veh/h/ln	1667	0	0	1651	0	0	1781	1777	1585	1781	1777	1585
Q Serve(g_s), s	0.0	0.0	0.0	0.2	0.0	0.0	0.4	4.8	0.8	0.9	4.8	0.6
Cycle Q Clear(g_c), s	1.4	0.0	0.0	1.7	0.0	0.0	0.4	4.8	0.8	0.9	4.8	0.6
Prop In Lane	0.43		0.14	0.22		0.50	1.00		1.00	1.00		1.00
Lane Grp Cap(c), veh/h	380	0	0	353	0	0	50	1184	528	105	1295	578
V/C Ratio(X)	0.24	0.00	0.00	0.28	0.00	0.00	0.44	0.56	0.11	0.50	0.53	0.08
Avail Cap(c_a), veh/h	1071	0	0	1062	0	0	284	2040	910	284	2040	910
HCM Platoon Ratio	1.00	1.00	1.00	1.00	1.00	1.00	1.00	1.00	1.00	1.00	1.00	1.00
Upstream Filter(l)	1.00	0.00	0.00	1.00	0.00	0.00	1.00	1.00	1.00	1.00	1.00	1.00
Uniform Delay (d), s/veh	12.5	0.0	0.0	12.6	0.0	0.0	15.0	8.6	7.2	14.3	7.9	6.5
Incr Delay (d2), s/veh	0.3	0.0	0.0	0.4	0.0	0.0	6.1	0.4	0.1	3.7	0.3	0.1
Initial Q Delay(d3),s/veh	0.0	0.0	0.0	0.0	0.0	0.0	0.0	0.0	0.0	0.0	0.0	0.0
%ile BackOfQ(50%),veh/ln	0.5	0.0	0.0	0.5	0.0	0.0	0.2	1.3	0.2	0.4	1.2	0.1
Unsig. Movement Delay, s/veh												
LnGrp Delay(d),s/veh	12.8	0.0	0.0	13.0	0.0	0.0	21.1	9.0	7.3	18.0	8.2	6.6
LnGrp LOS	B	A	A	B	A	A	C	A	A	B	A	A
Approach Vol, veh/h		91			100			749			786	
Approach Delay, s/veh		12.8			13.0			9.2			8.8	
Approach LOS		B			B			A			A	
Timer - Assigned Phs	1	2		4	5	6		8				
Phs Duration (G+Y+Rc), s	6.8	15.4		9.1	5.9	16.4		9.1				
Change Period (Y+Rc), s	5.0	5.0		5.0	5.0	5.0		5.0				
Max Green Setting (Gmax), s	5.0	18.0		18.0	5.0	18.0		18.0				
Max Q Clear Time (g_c+I1), s	2.9	6.8		3.4	2.4	6.8		3.7				
Green Ext Time (p_c), s	0.0	3.6		0.3	0.0	3.7		0.4				
Intersection Summary												
HCM 6th Ctrl Delay				9.4								
HCM 6th LOS				A								

Intersection												
Int Delay, s/veh	0.4											
Movement	EBL	EBT	EBR	WBL	WBT	WBR	NBL	NBT	NBR	SBL	SBT	SBR
Lane Configurations		↕			↕		↕	↕		↕	↕	
Traffic Vol, veh/h	21	3	2	1	2	6	0	672	1	1	625	8
Future Vol, veh/h	21	3	2	1	2	6	0	672	1	1	625	8
Conflicting Peds, #/hr	0	0	0	0	0	0	0	0	0	0	0	0
Sign Control	Stop	Stop	Stop	Stop	Stop	Stop	Free	Free	Free	Free	Free	Free
RT Channelized	-	-	None	-	-	None	-	-	None	-	-	None
Storage Length	-	-	-	-	-	-	50	-	-	50	-	-
Veh in Median Storage, #	-	1	-	-	1	-	-	0	-	-	0	-
Grade, %	-	0	-	-	0	-	-	0	-	-	0	-
Peak Hour Factor	94	94	94	94	94	94	94	94	94	94	94	94
Heavy Vehicles, %	2	2	2	2	2	2	2	2	2	2	2	2
Mvmt Flow	22	3	2	1	2	6	0	715	1	1	665	9

Major/Minor	Minor2		Minor1		Major1			Major2				
Conflicting Flow All	1031	1388	337	1052	1392	358	674	0	0	716	0	0
Stage 1	672	672	-	716	716	-	-	-	-	-	-	-
Stage 2	359	716	-	336	676	-	-	-	-	-	-	-
Critical Hdwy	7.54	6.54	6.94	7.54	6.54	6.94	4.14	-	-	4.14	-	-
Critical Hdwy Stg 1	6.54	5.54	-	6.54	5.54	-	-	-	-	-	-	-
Critical Hdwy Stg 2	6.54	5.54	-	6.54	5.54	-	-	-	-	-	-	-
Follow-up Hdwy	3.52	4.02	3.32	3.52	4.02	3.32	2.22	-	-	2.22	-	-
Pot Cap-1 Maneuver	187	142	659	181	141	638	913	-	-	880	-	-
Stage 1	412	453	-	387	432	-	-	-	-	-	-	-
Stage 2	632	432	-	652	451	-	-	-	-	-	-	-
Platoon blocked, %								-	-	-	-	-
Mov Cap-1 Maneuver	184	142	659	179	141	638	913	-	-	880	-	-
Mov Cap-2 Maneuver	305	266	-	295	266	-	-	-	-	-	-	-
Stage 1	412	453	-	387	432	-	-	-	-	-	-	-
Stage 2	623	432	-	645	451	-	-	-	-	-	-	-

Approach	EB		WB		NB			SB		
HCM Control Delay, s	17.6		13.3		0			0		
HCM LOS	C		B							

Minor Lane/Major Mvmt	NBL	NBT	NBR	EBLn1	WBLn1	SBL	SBT	SBR
Capacity (veh/h)	913	-	-	313	443	880	-	-
HCM Lane V/C Ratio	-	-	-	0.088	0.022	0.001	-	-
HCM Control Delay (s)	0	-	-	17.6	13.3	9.1	-	-
HCM Lane LOS	A	-	-	C	B	A	-	-
HCM 95th %tile Q(veh)	0	-	-	0.3	0.1	0	-	-

Heritage at Dalia Ranch
3: Imperial Ave & Ralph Rd

Opening Year 2028 + P1-4 Proj
Timing Plan: AM PEAK



Movement	EBL	EBT	EBR	WBL	WBT	WBR	NBL	NBT	NBR	SBL	SBT	SBR
Lane Configurations												
Traffic Volume (veh/h)	82	11	106	127	17	45	134	546	63	27	562	39
Future Volume (veh/h)	82	11	106	127	17	45	134	546	63	27	562	39
Initial Q (Qb), veh	0	0	0	0	0	0	0	0	0	0	0	0
Ped-Bike Adj(A_pbT)	1.00		1.00	1.00		1.00	1.00		1.00	1.00		1.00
Parking Bus, Adj	1.00	1.00	1.00	1.00	1.00	1.00	1.00	1.00	1.00	1.00	1.00	1.00
Work Zone On Approach		No			No			No			No	
Adj Sat Flow, veh/h/ln	1870	1870	1870	1870	1870	1870	1870	1870	1870	1870	1870	1870
Adj Flow Rate, veh/h	89	12	115	140	18	49	146	600	69	30	618	42
Peak Hour Factor	0.92	0.92	0.92	0.91	0.92	0.91	0.92	0.91	0.91	0.91	0.91	0.92
Percent Heavy Veh, %	2	2	2	2	2	2	2	2	2	2	2	2
Cap, veh/h	178	19	179	211	63	171	186	1035	119	61	896	399
Arrive On Green	0.10	0.12	0.12	0.12	0.14	0.14	0.10	0.32	0.32	0.03	0.25	0.25
Sat Flow, veh/h	1781	152	1456	1781	444	1209	1781	3212	369	1781	3554	1585
Grp Volume(v), veh/h	89	0	127	140	0	67	146	331	338	30	618	42
Grp Sat Flow(s),veh/h/ln	1781	0	1608	1781	0	1653	1781	1777	1804	1781	1777	1585
Q Serve(g_s), s	2.4	0.0	3.7	3.7	0.0	1.8	4.0	7.7	7.8	0.8	7.8	1.0
Cycle Q Clear(g_c), s	2.4	0.0	3.7	3.7	0.0	1.8	4.0	7.7	7.8	0.8	7.8	1.0
Prop In Lane	1.00		0.91	1.00		0.73	1.00		0.20	1.00		1.00
Lane Grp Cap(c), veh/h	178	0	197	211	0	234	186	572	581	61	896	399
V/C Ratio(X)	0.50	0.00	0.64	0.66	0.00	0.29	0.79	0.58	0.58	0.49	0.69	0.11
Avail Cap(c_a), veh/h	645	0	582	645	0	598	215	679	689	179	1287	574
HCM Platoon Ratio	1.00	1.00	1.00	1.00	1.00	1.00	1.00	1.00	1.00	1.00	1.00	1.00
Upstream Filter(l)	1.00	0.00	1.00	1.00	0.00	1.00	1.00	1.00	1.00	1.00	1.00	1.00
Uniform Delay (d), s/veh	21.2	0.0	20.8	21.0	0.0	19.1	21.7	14.0	14.1	23.6	16.8	14.3
Incr Delay (d2), s/veh	2.2	0.0	3.5	3.5	0.0	0.7	15.3	0.9	0.9	6.1	1.0	0.1
Initial Q Delay(d3),s/veh	0.0	0.0	0.0	0.0	0.0	0.0	0.0	0.0	0.0	0.0	0.0	0.0
%ile BackOfQ(50%),veh/ln	1.0	0.0	1.5	1.6	0.0	0.7	2.3	2.8	2.8	0.4	2.9	0.3
Unsig. Movement Delay, s/veh												
LnGrp Delay(d),s/veh	23.4	0.0	24.2	24.5	0.0	19.8	37.0	15.0	15.0	29.7	17.8	14.4
LnGrp LOS	C	A	C	C	A	B	D	B	B	C	B	B
Approach Vol, veh/h		216			207			815			690	
Approach Delay, s/veh		23.9			22.9			18.9			18.1	
Approach LOS		C			C			B			B	
Timer - Assigned Phs	1	2	3	4	5	6	7	8				
Phs Duration (G+Y+Rc), s	6.7	21.0	10.9	11.1	10.2	17.5	10.0	12.0				
Change Period (Y+Rc), s	5.0	5.0	5.0	5.0	5.0	5.0	5.0	5.0				
Max Green Setting (Gmax), s	5.0	19.0	18.0	18.0	6.0	18.0	18.0	18.0				
Max Q Clear Time (g_c+I1), s	2.8	9.8	5.7	5.7	6.0	9.8	4.4	3.8				
Green Ext Time (p_c), s	0.0	2.8	0.3	0.5	0.0	2.7	0.2	0.2				
Intersection Summary												
HCM 6th Ctrl Delay			19.6									
HCM 6th LOS			B									

Heritage at Dalia Ranch
4: Imperial Ave & Neckel Rd

Opening Year 2028 + P1-4 Proj
Timing Plan: AM PEAK



Movement	EBL	EBT	EBR	WBL	WBT	WBR	NBL	NBT	NBR	SBL	SBT	SBR
Lane Configurations		↕			↕		↗	↕		↗	↕	
Traffic Volume (veh/h)	36	46	143	232	68	104	54	610	96	35	750	33
Future Volume (veh/h)	36	46	143	232	68	104	54	610	96	35	750	33
Initial Q (Qb), veh	0	0	0	0	0	0	0	0	0	0	0	0
Ped-Bike Adj(A_pbT)	1.00		1.00	1.00		1.00	1.00		1.00	1.00		1.00
Parking Bus, Adj	1.00	1.00	1.00	1.00	1.00	1.00	1.00	1.00	1.00	1.00	1.00	1.00
Work Zone On Approach		No			No			No			No	
Adj Sat Flow, veh/h/ln	1870	1870	1870	1870	1870	1870	1870	1870	1870	1870	1870	1870
Adj Flow Rate, veh/h	40	51	157	255	75	114	59	670	105	38	824	36
Peak Hour Factor	0.91	0.91	0.91	0.91	0.91	0.91	0.91	0.91	0.91	0.91	0.91	0.91
Percent Heavy Veh, %	2	2	2	2	2	2	2	2	2	2	2	2
Cap, veh/h	48	61	188	244	72	109	85	828	130	65	895	39
Arrive On Green	0.18	0.18	0.18	0.24	0.24	0.24	0.05	0.27	0.27	0.04	0.26	0.26
Sat Flow, veh/h	269	343	1055	999	294	447	1781	3079	482	1781	3468	152
Grp Volume(v), veh/h	248	0	0	444	0	0	59	386	389	38	422	438
Grp Sat Flow(s),veh/h/ln	1667	0	0	1740	0	0	1781	1777	1784	1781	1777	1843
Q Serve(g_s), s	10.6	0.0	0.0	18.0	0.0	0.0	2.4	15.0	15.0	1.5	17.0	17.0
Cycle Q Clear(g_c), s	10.6	0.0	0.0	18.0	0.0	0.0	2.4	15.0	15.0	1.5	17.0	17.0
Prop In Lane	0.16		0.63	0.57		0.26	1.00		0.27	1.00		0.08
Lane Grp Cap(c), veh/h	298	0	0	425	0	0	85	478	480	65	458	475
V/C Ratio(X)	0.83	0.00	0.00	1.04	0.00	0.00	0.70	0.81	0.81	0.58	0.92	0.92
Avail Cap(c_a), veh/h	407	0	0	425	0	0	121	478	480	121	458	475
HCM Platoon Ratio	1.00	1.00	1.00	1.00	1.00	1.00	1.00	1.00	1.00	1.00	1.00	1.00
Upstream Filter(l)	1.00	0.00	0.00	1.00	0.00	0.00	1.00	1.00	1.00	1.00	1.00	1.00
Uniform Delay (d), s/veh	29.2	0.0	0.0	27.8	0.0	0.0	34.5	25.2	25.2	34.9	26.6	26.6
Incr Delay (d2), s/veh	10.3	0.0	0.0	55.6	0.0	0.0	9.8	10.0	10.1	7.9	23.9	23.3
Initial Q Delay(d3),s/veh	0.0	0.0	0.0	0.0	0.0	0.0	0.0	0.0	0.0	0.0	0.0	0.0
%ile BackOfQ(50%),veh/ln	4.9	0.0	0.0	13.6	0.0	0.0	1.2	7.3	7.3	0.8	9.9	10.2
Unsig. Movement Delay, s/veh												
LnGrp Delay(d),s/veh	39.5	0.0	0.0	83.4	0.0	0.0	44.4	35.2	35.2	42.9	50.5	49.9
LnGrp LOS	D	A	A	F	A	A	D	D	D	D	D	D
Approach Vol, veh/h		248			444			834			898	
Approach Delay, s/veh		39.5			83.4			35.8			49.9	
Approach LOS		D			F			D			D	
Timer - Assigned Phs	1	2		4	5	6		8				
Phs Duration (G+Y+Rc), s	7.7	24.8		18.1	8.5	24.0		23.0				
Change Period (Y+Rc), s	5.0	5.0		5.0	5.0	5.0		5.0				
Max Green Setting (Gmax), s	5.0	19.0		18.0	5.0	19.0		18.0				
Max Q Clear Time (g_c+1), s	13.5	17.0		12.6	4.4	19.0		20.0				
Green Ext Time (p_c), s	0.0	1.0		0.7	0.0	0.0		0.0				

Intersection Summary

HCM 6th Ctrl Delay				50.1								
HCM 6th LOS				D								

Intersection												
Int Delay, s/veh	11.9											
Movement	EBL	EBT	EBR	WBL	WBT	WBR	NBL	NBT	NBR	SBL	SBT	SBR
Lane Configurations		↕			↕			↕			↕	
Traffic Vol, veh/h	4	44	24	71	47	94	8	33	48	155	36	1
Future Vol, veh/h	4	44	24	71	47	94	8	33	48	155	36	1
Conflicting Peds, #/hr	0	0	0	0	0	0	0	0	0	0	0	0
Sign Control	Stop	Stop	Stop	Stop	Stop	Stop	Free	Free	Free	Free	Free	Free
RT Channelized	-	-	None	-	-	None	-	-	None	-	-	None
Storage Length	-	-	-	-	-	-	-	-	-	-	-	-
Veh in Median Storage, #	-	0	-	-	0	-	-	0	-	-	0	-
Grade, %	-	0	-	-	0	-	-	0	-	-	0	-
Peak Hour Factor	79	79	79	79	79	79	79	79	79	79	79	79
Heavy Vehicles, %	2	2	2	2	2	2	2	2	2	2	2	2
Mvmt Flow	5	56	30	90	59	119	10	42	61	196	46	1

Major/Minor	Minor2		Minor1		Major1			Major2				
Conflicting Flow All	621	562	47	575	532	73	47	0	0	103	0	0
Stage 1	439	439	-	93	93	-	-	-	-	-	-	-
Stage 2	182	123	-	482	439	-	-	-	-	-	-	-
Critical Hdwy	7.12	6.52	6.22	7.12	6.52	6.22	4.12	-	-	4.12	-	-
Critical Hdwy Stg 1	6.12	5.52	-	6.12	5.52	-	-	-	-	-	-	-
Critical Hdwy Stg 2	6.12	5.52	-	6.12	5.52	-	-	-	-	-	-	-
Follow-up Hdwy	3.518	4.018	3.318	3.518	4.018	3.318	2.218	-	-	2.218	-	-
Pot Cap-1 Maneuver	400	436	1022	429	453	989	1560	-	-	1489	-	-
Stage 1	597	578	-	914	818	-	-	-	-	-	-	-
Stage 2	820	794	-	565	578	-	-	-	-	-	-	-
Platoon blocked, %								-	-	-	-	-
Mov Cap-1 Maneuver	278	375	1022	330	389	989	1560	-	-	1489	-	-
Mov Cap-2 Maneuver	278	375	-	330	389	-	-	-	-	-	-	-
Stage 1	593	500	-	908	812	-	-	-	-	-	-	-
Stage 2	664	788	-	421	500	-	-	-	-	-	-	-

Approach	EB		WB		NB		SB	
HCM Control Delay, s	14.6		20.7		0.7		6.3	
HCM LOS	B		C					

Minor Lane/Major Mvmt	NBL	NBT	NBR	EBLn1WBLn1	SBL	SBT	SBR
Capacity (veh/h)	1560	-	-	464	492	1489	-
HCM Lane V/C Ratio	0.006	-	-	0.196	0.545	0.132	-
HCM Control Delay (s)	7.3	0	-	14.6	20.7	7.8	0
HCM Lane LOS	A	A	-	B	C	A	A
HCM 95th %tile Q(veh)	0	-	-	0.7	3.2	0.5	-

Heritage at Dalia Ranch
6: Imperial Ave & Worthington Rd/Barioni Blvd

Opening Year 2028 + P1-4 Proj
Timing Plan: AM PEAK

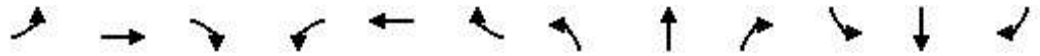

Movement	EBL	EBT	EBR	WBL	WBT	WBR	NBL	NBT	NBR	SBL	SBT	SBR
Lane Configurations		↕	↗		↕	↗	↗	↕↗		↗	↕↗	
Traffic Volume (veh/h)	83	145	227	58	141	111	99	670	54	84	1022	84
Future Volume (veh/h)	83	145	227	58	141	111	99	670	54	84	1022	84
Initial Q (Qb), veh	0	0	0	0	0	0	0	0	0	0	0	0
Ped-Bike Adj(A_pbT)	1.00		1.00	1.00		1.00	1.00		1.00	1.00		1.00
Parking Bus, Adj	1.00	1.00	1.00	1.00	1.00	1.00	1.00	1.00	1.00	1.00	1.00	1.00
Work Zone On Approach		No			No			No			No	
Adj Sat Flow, veh/h/ln	1870	1870	1870	1870	1870	1870	1870	1870	1870	1870	1870	1870
Adj Flow Rate, veh/h	93	163	255	65	158	125	111	753	61	94	1148	94
Peak Hour Factor	0.89	0.89	0.89	0.89	0.89	0.89	0.89	0.89	0.89	0.89	0.89	0.89
Percent Heavy Veh, %	2	2	2	2	2	2	2	2	2	2	2	2
Cap, veh/h	127	222	300	82	199	241	130	1155	94	120	1136	93
Arrive On Green	0.19	0.19	0.19	0.15	0.15	0.15	0.07	0.35	0.35	0.07	0.34	0.34
Sat Flow, veh/h	667	1170	1585	537	1306	1585	1781	3329	270	1781	3326	272
Grp Volume(v), veh/h	256	0	255	223	0	125	111	402	412	94	613	629
Grp Sat Flow(s),veh/h/ln	1837	0	1585	1843	0	1585	1781	1777	1822	1781	1777	1821
Q Serve(g_s), s	10.8	0.0	12.7	9.6	0.0	6.0	5.1	15.6	15.7	4.3	28.0	28.0
Cycle Q Clear(g_c), s	10.8	0.0	12.7	9.6	0.0	6.0	5.1	15.6	15.7	4.3	28.0	28.0
Prop In Lane	0.36		1.00	0.29		1.00	1.00		0.15	1.00		0.15
Lane Grp Cap(c), veh/h	348	0	300	280	0	241	130	617	632	120	607	622
V/C Ratio(X)	0.74	0.00	0.85	0.80	0.00	0.52	0.85	0.65	0.65	0.78	1.01	1.01
Avail Cap(c_a), veh/h	403	0	348	405	0	348	130	617	632	152	607	622
HCM Platoon Ratio	1.00	1.00	1.00	1.00	1.00	1.00	1.00	1.00	1.00	1.00	1.00	1.00
Upstream Filter(l)	1.00	0.00	1.00	1.00	0.00	1.00	1.00	1.00	1.00	1.00	1.00	1.00
Uniform Delay (d), s/veh	31.3	0.0	32.1	33.5	0.0	32.0	37.6	22.6	22.6	37.6	27.0	27.0
Incr Delay (d2), s/veh	5.8	0.0	15.8	6.9	0.0	1.7	38.6	2.4	2.4	18.2	39.0	39.1
Initial Q Delay(d3),s/veh	0.0	0.0	0.0	0.0	0.0	0.0	0.0	0.0	0.0	0.0	0.0	0.0
%ile BackOfQ(50%),veh/ln	5.2	0.0	6.1	4.7	0.0	2.3	3.6	6.6	6.8	2.4	17.8	18.2
Unsig. Movement Delay, s/veh												
LnGrp Delay(d),s/veh	37.1	0.0	47.9	40.4	0.0	33.7	76.2	25.0	25.0	55.8	66.1	66.1
LnGrp LOS	D	A	D	D	A	C	E	C	C	E	F	F
Approach Vol, veh/h		511			348			925			1336	
Approach Delay, s/veh		42.5			38.0			31.1			65.4	
Approach LOS		D			D			C			E	
Timer - Assigned Phs	1	2		4	5	6		8				
Phs Duration (G+Y+Rc), s	10.5	33.5		20.5	11.0	33.0		17.5				
Change Period (Y+Rc), s	5.0	5.0		5.0	5.0	5.0		5.0				
Max Green Setting (Gmax), s	7.0	27.0		18.0	6.0	28.0		18.0				
Max Q Clear Time (g_c+I1), s	6.3	17.7		14.7	7.1	30.0		11.6				
Green Ext Time (p_c), s	0.0	3.5		0.8	0.0	0.0		0.9				
Intersection Summary												
HCM 6th Ctrl Delay			48.4									
HCM 6th LOS			D									

Intersection												
Intersection Delay, s/veh	34.2											
Intersection LOS	D											

Movement	EBL	EBT	EBR	WBL	WBT	WBR	NBL	NBT	NBR	SBL	SBT	SBR
Lane Configurations		↔	↔		↔	↔		↔			↔	
Traffic Vol, veh/h	93	426	128	12	347	83	0	0	1	114	33	110
Future Vol, veh/h	93	426	128	12	347	83	0	0	1	114	33	110
Peak Hour Factor	0.92	0.92	0.92	0.92	0.92	0.92	0.92	0.92	0.92	0.92	0.92	0.92
Heavy Vehicles, %	2	2	2	2	2	2	2	2	2	2	2	2
Mvmt Flow	101	463	139	13	377	90	0	0	1	124	36	120
Number of Lanes	0	1	1	0	1	1	0	1	0	0	1	0

Approach	EB	WB	NB	SB
Opposing Approach	WB	EB	SB	NB
Opposing Lanes	2	2	1	1
Conflicting Approach Left	SB	NB	EB	WB
Conflicting Lanes Left	1	1	2	2
Conflicting Approach Right	NB	SB	WB	EB
Conflicting Lanes Right	1	1	2	2
HCM Control Delay	50.3	21.1	10.4	16.3
HCM LOS	F	C	B	C

Lane	NBLn1	EBLn1	EBLn2	WBLn1	WBLn2	SBLn1
Vol Left, %	0%	18%	0%	3%	0%	44%
Vol Thru, %	0%	82%	0%	97%	0%	13%
Vol Right, %	100%	0%	100%	0%	100%	43%
Sign Control	Stop	Stop	Stop	Stop	Stop	Stop
Traffic Vol by Lane	1	519	128	359	83	257
LT Vol	0	93	0	12	0	114
Through Vol	0	426	0	347	0	33
RT Vol	1	0	128	0	83	110
Lane Flow Rate	1	564	139	390	90	279
Geometry Grp	2	7	7	7	7	2
Degree of Util (X)	0.002	0.99	0.213	0.708	0.145	0.509
Departure Headway (Hd)	7.38	6.319	5.515	6.53	5.799	6.562
Convergence, Y/N	Yes	Yes	Yes	Yes	Yes	Yes
Cap	488	570	646	550	613	545
Service Time	5.38	4.094	3.29	4.315	3.583	4.643
HCM Lane V/C Ratio	0.002	0.989	0.215	0.709	0.147	0.512
HCM Control Delay	10.4	60.3	9.8	23.8	9.6	16.3
HCM Lane LOS	B	F	A	C	A	C
HCM 95th-tile Q	0	14.1	0.8	5.7	0.5	2.9

Heritage at Dalia Ranch
8: Imperial Ave & Aten Rd

Opening Year 2028 + P1-4 Proj
Timing Plan: AM PEAK



Movement	EBL	EBT	EBR	WBL	WBT	WBR	NBL	NBT	NBR	SBL	SBT	SBR
Lane Configurations												
Traffic Volume (veh/h)	236	362	67	140	321	179	65	475	72	194	959	468
Future Volume (veh/h)	236	362	67	140	321	179	65	475	72	194	959	468
Initial Q (Qb), veh	0	0	0	0	0	0	0	0	0	0	0	0
Ped-Bike Adj(A_pbT)	1.00		1.00	1.00		1.00	1.00		1.00	1.00		1.00
Parking Bus, Adj	1.00	1.00	1.00	1.00	1.00	1.00	1.00	1.00	1.00	1.00	1.00	1.00
Work Zone On Approach		No		No		No		No		No		No
Adj Sat Flow, veh/h/ln	1870	1870	1870	1870	1870	1870	1870	1870	1870	1870	1870	1870
Adj Flow Rate, veh/h	274	421	78	163	373	208	76	552	84	226	1115	544
Peak Hour Factor	0.86	0.86	0.86	0.86	0.86	0.86	0.86	0.86	0.86	0.86	0.86	0.86
Percent Heavy Veh, %	2	2	2	2	2	2	2	2	2	2	2	2
Cap, veh/h	301	780	143	202	454	249	97	794	354	254	1107	494
Arrive On Green	0.17	0.26	0.26	0.11	0.21	0.21	0.05	0.22	0.22	0.14	0.31	0.31
Sat Flow, veh/h	1781	2997	551	1781	2213	1215	1781	3554	1585	1781	3554	1585
Grp Volume(v), veh/h	274	248	251	163	298	283	76	552	84	226	1115	544
Grp Sat Flow(s),veh/h/ln	1781	1777	1771	1781	1777	1652	1781	1777	1585	1781	1777	1585
Q Serve(g_s), s	11.6	9.3	9.4	6.9	12.4	12.6	3.2	11.0	3.3	9.6	24.0	24.0
Cycle Q Clear(g_c), s	11.6	9.3	9.4	6.9	12.4	12.6	3.2	11.0	3.3	9.6	24.0	24.0
Prop In Lane	1.00		0.31	1.00		0.74	1.00		1.00	1.00		1.00
Lane Grp Cap(c), veh/h	301	463	461	202	365	339	97	794	354	254	1107	494
V/C Ratio(X)	0.91	0.54	0.54	0.81	0.82	0.83	0.78	0.70	0.24	0.89	1.01	1.10
Avail Cap(c_a), veh/h	301	463	461	301	415	386	116	831	370	254	1107	494
HCM Platoon Ratio	1.00	1.00	1.00	1.00	1.00	1.00	1.00	1.00	1.00	1.00	1.00	1.00
Upstream Filter(l)	1.00	1.00	1.00	1.00	1.00	1.00	1.00	1.00	1.00	1.00	1.00	1.00
Uniform Delay (d), s/veh	31.4	24.5	24.5	33.3	29.2	29.3	35.9	27.5	24.5	32.4	26.5	26.5
Incr Delay (d2), s/veh	30.2	1.2	1.3	9.4	10.9	13.2	24.3	2.4	0.3	29.3	28.7	71.0
Initial Q Delay(d3),s/veh	0.0	0.0	0.0	0.0	0.0	0.0	0.0	0.0	0.0	0.0	0.0	0.0
%ile BackOfQ(50%),veh/ln	7.3	3.9	3.9	3.4	6.2	6.1	2.0	4.8	1.2	6.1	14.0	18.2
Unsig. Movement Delay, s/veh												
LnGrp Delay(d),s/veh	61.6	25.7	25.9	42.7	40.2	42.5	60.3	29.9	24.9	61.7	55.2	97.5
LnGrp LOS	E	C	C	D	D	D	E	C	C	E	F	F
Approach Vol, veh/h		773			744			712			1885	
Approach Delay, s/veh		38.5			41.6			32.5			68.2	
Approach LOS		D			D			C			E	
Timer - Assigned Phs	1	2	3	4	5	6	7	8				
Phs Duration (G+Y+Rc), s	6.0	22.2	13.8	25.1	9.2	29.0	18.0	20.8				
Change Period (Y+Rc), s	5.0	5.0	5.0	5.0	5.0	5.0	5.0	5.0				
Max Green Setting (Gmax), s	18.0	18.0	13.0	18.0	5.0	24.0	13.0	18.0				
Max Q Clear Time (g_c+ll), s	13.0	13.0	8.9	11.4	5.2	26.0	13.6	14.6				
Green Ext Time (p_c), s	0.0	1.8	0.2	1.6	0.0	0.0	0.0	1.2				
Intersection Summary												
HCM 6th Ctrl Delay											51.6	
HCM 6th LOS											D	

Intersection						
Int Delay, s/veh	1.7					
Movement	EBL	EBT	WBT	WBR	SBL	SBR
Lane Configurations	↖	↑	↗		↖	↗
Traffic Vol, veh/h	3	174	137	18	52	7
Future Vol, veh/h	3	174	137	18	52	7
Conflicting Peds, #/hr	0	0	0	0	0	0
Sign Control	Free	Free	Free	Free	Stop	Stop
RT Channelized	-	None	-	None	-	None
Storage Length	50	-	-	-	0	0
Veh in Median Storage, #	-	0	0	-	0	-
Grade, %	-	0	0	-	0	-
Peak Hour Factor	92	92	92	92	92	92
Heavy Vehicles, %	2	2	2	2	2	2
Mvmt Flow	3	189	149	20	57	8

Major/Minor	Major1	Major2	Minor2		
Conflicting Flow All	169	0	-	0	354 159
Stage 1	-	-	-	-	159 -
Stage 2	-	-	-	-	195 -
Critical Hdwy	4.12	-	-	-	6.42 6.22
Critical Hdwy Stg 1	-	-	-	-	5.42 -
Critical Hdwy Stg 2	-	-	-	-	5.42 -
Follow-up Hdwy	2.218	-	-	-	3.518 3.318
Pot Cap-1 Maneuver	1409	-	-	-	644 886
Stage 1	-	-	-	-	870 -
Stage 2	-	-	-	-	838 -
Platoon blocked, %		-	-	-	
Mov Cap-1 Maneuver	1409	-	-	-	643 886
Mov Cap-2 Maneuver	-	-	-	-	643 -
Stage 1	-	-	-	-	868 -
Stage 2	-	-	-	-	838 -

Approach	EB	WB	SB
HCM Control Delay, s	0.1	0	10.9
HCM LOS			B

Minor Lane/Major Mvmt	EBL	EBT	WBT	WBR	SBLn1	SBLn2
Capacity (veh/h)	1409	-	-	-	643	886
HCM Lane V/C Ratio	0.002	-	-	-	0.088	0.009
HCM Control Delay (s)	7.6	-	-	-	11.1	9.1
HCM Lane LOS	A	-	-	-	B	A
HCM 95th %tile Q(veh)	0	-	-	-	0.3	0

Intersection												
Int Delay, s/veh	5.5											
Movement	EBL	EBT	EBR	WBL	WBT	WBR	NBL	NBT	NBR	SBL	SBT	SBR
Lane Configurations		↕	↕		↕	↕	↕	↕		↕	↕	
Traffic Vol, veh/h	22	0	90	7	0	0	30	43	3	0	32	8
Future Vol, veh/h	22	0	90	7	0	0	30	43	3	0	32	8
Conflicting Peds, #/hr	0	0	0	0	0	0	0	0	0	0	0	0
Sign Control	Stop	Stop	Stop	Stop	Stop	Stop	Free	Free	Free	Free	Free	Free
RT Channelized	-	-	None	-	-	None	-	-	None	-	-	None
Storage Length	-	-	0	-	-	0	0	-	-	50	-	-
Veh in Median Storage, #	-	0	-	-	0	-	-	0	-	-	0	-
Grade, %	-	0	-	-	0	-	-	0	-	-	0	-
Peak Hour Factor	92	92	92	92	92	92	92	92	92	92	92	92
Heavy Vehicles, %	2	2	2	2	2	2	2	2	2	2	2	2
Mvmt Flow	24	0	98	8	0	0	33	47	3	0	35	9

Major/Minor	Minor2		Minor1		Major1			Major2				
Conflicting Flow All	155	156	40	204	159	49	44	0	0	50	0	0
Stage 1	40	40	-	115	115	-	-	-	-	-	-	-
Stage 2	115	116	-	89	44	-	-	-	-	-	-	-
Critical Hdwy	7.12	6.52	6.22	7.12	6.52	6.22	4.12	-	-	4.12	-	-
Critical Hdwy Stg 1	6.12	5.52	-	6.12	5.52	-	-	-	-	-	-	-
Critical Hdwy Stg 2	6.12	5.52	-	6.12	5.52	-	-	-	-	-	-	-
Follow-up Hdwy	3.518	4.018	3.318	3.518	4.018	3.318	2.218	-	-	2.218	-	-
Pot Cap-1 Maneuver	812	736	1031	754	733	1020	1564	-	-	1557	-	-
Stage 1	975	862	-	890	800	-	-	-	-	-	-	-
Stage 2	890	800	-	918	858	-	-	-	-	-	-	-
Platoon blocked, %								-	-	-	-	-
Mov Cap-1 Maneuver	799	721	1031	672	718	1020	1564	-	-	1557	-	-
Mov Cap-2 Maneuver	799	721	-	672	718	-	-	-	-	-	-	-
Stage 1	955	862	-	871	783	-	-	-	-	-	-	-
Stage 2	871	783	-	831	858	-	-	-	-	-	-	-

Approach	EB		WB		NB		SB	
HCM Control Delay, s	9		10.4		2.9		0	
HCM LOS	A		B					

Minor Lane/Major Mvmt	NBL	NBT	NBR	EBLn1	EBLn2	WBLn1	WBLn2	SBL	SBT	SBR
Capacity (veh/h)	1564	-	-	799	1031	672	-	1557	-	-
HCM Lane V/C Ratio	0.021	-	-	0.03	0.095	0.011	-	-	-	-
HCM Control Delay (s)	7.4	-	-	9.6	8.9	10.4	0	0	-	-
HCM Lane LOS	A	-	-	A	A	B	A	A	-	-
HCM 95th %tile Q(veh)	0.1	-	-	0.1	0.3	0	-	0	-	-

Intersection						
Int Delay, s/veh	4.7					
Movement	EBT	EBR	WBL	WBT	NBL	NBR
Lane Configurations						
Traffic Vol, veh/h	54	0	28	36	0	81
Future Vol, veh/h	54	0	28	36	0	81
Conflicting Peds, #/hr	0	0	0	0	0	0
Sign Control	Free	Free	Free	Free	Stop	Stop
RT Channelized	-	None	-	None	-	None
Storage Length	-	-	50	-	0	0
Veh in Median Storage, #	0	-	-	0	0	-
Grade, %	0	-	-	0	0	-
Peak Hour Factor	92	92	92	92	92	92
Heavy Vehicles, %	2	2	2	2	2	2
Mvmt Flow	59	0	30	39	0	88

Major/Minor	Major1	Major2	Minor1	Minor2	Minor3
Conflicting Flow All	0	0	59	0	158
Stage 1	-	-	-	-	59
Stage 2	-	-	-	-	99
Critical Hdwy	-	-	4.12	-	6.42
Critical Hdwy Stg 1	-	-	-	-	5.42
Critical Hdwy Stg 2	-	-	-	-	5.42
Follow-up Hdwy	-	-	2.218	-	3.518
Pot Cap-1 Maneuver	-	-	1545	-	833
Stage 1	-	-	-	-	964
Stage 2	-	-	-	-	925
Platoon blocked, %	-	-	-	-	-
Mov Cap-1 Maneuver	-	-	1545	-	817
Mov Cap-2 Maneuver	-	-	-	-	817
Stage 1	-	-	-	-	964
Stage 2	-	-	-	-	907

Approach	EB	WB	NB
HCM Control Delay, s	0	3.2	8.9
HCM LOS			A

Minor Lane/Major Mvmt	NBLn1	NBLn2	EBT	EBR	WBL	WBT
Capacity (veh/h)	-	1007	-	-	1545	-
HCM Lane V/C Ratio	-	0.087	-	-	0.02	-
HCM Control Delay (s)	0	8.9	-	-	7.4	-
HCM Lane LOS	A	A	-	-	A	-
HCM 95th %tile Q(veh)	-	0.3	-	-	0.1	-

Intersection						
Int Delay, s/veh	2.2					
Movement	EBT	EBR	WBL	WBT	NBL	NBR
Lane Configurations	↔		↔	↑	↔	↔
Traffic Vol, veh/h	133	2	16	59	5	42
Future Vol, veh/h	133	2	16	59	5	42
Conflicting Peds, #/hr	0	0	0	0	0	0
Sign Control	Free	Free	Free	Free	Stop	Stop
RT Channelized	-	None	-	None	-	None
Storage Length	-	-	50	-	0	0
Veh in Median Storage, #	0	-	-	0	0	-
Grade, %	0	-	-	0	0	-
Peak Hour Factor	92	92	92	92	92	92
Heavy Vehicles, %	2	2	2	2	2	2
Mvmt Flow	145	2	17	64	5	46

Major/Minor	Major1	Major2	Minor1		
Conflicting Flow All	0	0	147	0	244
Stage 1	-	-	-	-	146
Stage 2	-	-	-	-	98
Critical Hdwy	-	-	4.12	-	6.42
Critical Hdwy Stg 1	-	-	-	-	5.42
Critical Hdwy Stg 2	-	-	-	-	5.42
Follow-up Hdwy	-	-	2.218	-	3.518
Pot Cap-1 Maneuver	-	-	1435	-	744
Stage 1	-	-	-	-	881
Stage 2	-	-	-	-	926
Platoon blocked, %	-	-	-	-	-
Mov Cap-1 Maneuver	-	-	1435	-	735
Mov Cap-2 Maneuver	-	-	-	-	735
Stage 1	-	-	-	-	881
Stage 2	-	-	-	-	915

Approach	EB	WB	NB
HCM Control Delay, s	0	1.6	9.3
HCM LOS			A

Minor Lane/Major Mvmt	NBLn1	NBLn2	EBT	EBR	WBL	WBT
Capacity (veh/h)	735	901	-	-	1435	-
HCM Lane V/C Ratio	0.007	0.051	-	-	0.012	-
HCM Control Delay (s)	9.9	9.2	-	-	7.5	-
HCM Lane LOS	A	A	-	-	A	-
HCM 95th %tile Q(veh)	0	0.2	-	-	0	-

Intersection						
Int Delay, s/veh	5.8					
Movement	EBT	EBR	WBL	WBT	NBL	NBR
Lane Configurations	↔		↔	↑	↔	↔
Traffic Vol, veh/h	145	30	242	52	23	116
Future Vol, veh/h	145	30	242	52	23	116
Conflicting Peds, #/hr	0	0	0	0	0	0
Sign Control	Free	Free	Free	Free	Stop	Stop
RT Channelized	-	None	-	None	-	None
Storage Length	-	-	100	-	0	0
Veh in Median Storage, #	0	-	-	0	0	-
Grade, %	0	-	-	0	0	-
Peak Hour Factor	92	92	92	92	92	92
Heavy Vehicles, %	2	2	2	2	2	2
Mvmt Flow	158	33	263	57	25	126

Major/Minor	Major1	Major2	Minor1		
Conflicting Flow All	0	0	191	0	758
Stage 1	-	-	-	-	175
Stage 2	-	-	-	-	583
Critical Hdwy	-	-	4.12	-	6.42
Critical Hdwy Stg 1	-	-	-	-	5.42
Critical Hdwy Stg 2	-	-	-	-	5.42
Follow-up Hdwy	-	-	2.218	-	3.518
Pot Cap-1 Maneuver	-	-	1383	-	375
Stage 1	-	-	-	-	855
Stage 2	-	-	-	-	558
Platoon blocked, %	-	-	-	-	-
Mov Cap-1 Maneuver	-	-	1383	-	304
Mov Cap-2 Maneuver	-	-	-	-	304
Stage 1	-	-	-	-	855
Stage 2	-	-	-	-	452

Approach	EB	WB	NB
HCM Control Delay, s	0	6.8	11.2
HCM LOS			B

Minor Lane/Major Mvmt	NBLn1	NBLn2	EBT	EBR	WBL	WBT
Capacity (veh/h)	304	868	-	-	1383	-
HCM Lane V/C Ratio	0.082	0.145	-	-	0.19	-
HCM Control Delay (s)	17.9	9.9	-	-	8.2	-
HCM Lane LOS	C	A	-	-	A	-
HCM 95th %tile Q(veh)	0.3	0.5	-	-	0.7	-

Intersection						
Int Delay, s/veh	0.7					
Movement	EBL	EBR	NBL	NBT	SBT	SBR
Lane Configurations		↗		↕↕	↕↕	↗
Traffic Vol, veh/h	0	92	0	775	730	30
Future Vol, veh/h	0	92	0	775	730	30
Conflicting Peds, #/hr	0	0	0	0	0	0
Sign Control	Stop	Stop	Free	Free	Free	Free
RT Channelized	-	None	-	None	-	None
Storage Length	-	0	-	-	-	100
Veh in Median Storage, #	0	-	-	0	0	-
Grade, %	0	-	-	0	0	-
Peak Hour Factor	92	92	92	92	92	92
Heavy Vehicles, %	2	2	2	2	2	2
Mvmt Flow	0	100	0	842	793	33

Major/Minor	Minor2	Major1	Major2
Conflicting Flow All	-	397	0
Stage 1	-	-	-
Stage 2	-	-	-
Critical Hdwy	-	6.94	-
Critical Hdwy Stg 1	-	-	-
Critical Hdwy Stg 2	-	-	-
Follow-up Hdwy	-	3.32	-
Pot Cap-1 Maneuver	0	602	0
Stage 1	0	-	0
Stage 2	0	-	0
Platoon blocked, %	-	-	-
Mov Cap-1 Maneuver	-	602	-
Mov Cap-2 Maneuver	-	-	-
Stage 1	-	-	-
Stage 2	-	-	-

Approach	EB	NB	SB
HCM Control Delay, s	12.2	0	0
HCM LOS	B		

Minor Lane/Major Mvmt	NBT EBLn1	SBT	SBR
Capacity (veh/h)	-	602	-
HCM Lane V/C Ratio	-	0.166	-
HCM Control Delay (s)	-	12.2	-
HCM Lane LOS	-	B	-
HCM 95th %tile Q(veh)	-	0.6	-

Heritage at Dalia Ranch
1: SR-86 & Keystone Rd

Opening Year 2028 + P1-4 Proj
Timing Plan: PM PEAK

Movement	EBL	EBT	EBR	WBL	WBT	WBR	NBL	NBT	NBR	SBL	SBT	SBR
Lane Configurations												
Traffic Volume (veh/h)	44	13	21	35	29	40	11	672	28	56	734	36
Future Volume (veh/h)	44	13	21	35	29	40	11	672	28	56	734	36
Initial Q (Qb), veh	0	0	0	0	0	0	0	0	0	0	0	0
Ped-Bike Adj(A_pbT)	1.00		1.00	1.00		1.00	1.00		1.00	1.00		1.00
Parking Bus, Adj	1.00	1.00	1.00	1.00	1.00	1.00	1.00	1.00	1.00	1.00	1.00	1.00
Work Zone On Approach		No			No			No			No	
Adj Sat Flow, veh/h/ln	1870	1870	1870	1870	1870	1870	1870	1870	1870	1870	1870	1870
Adj Flow Rate, veh/h	49	15	24	39	33	45	12	755	31	63	825	40
Peak Hour Factor	0.89	0.89	0.89	0.89	0.89	0.89	0.89	0.89	0.89	0.89	0.89	0.89
Percent Heavy Veh, %	2	2	2	2	2	2	2	2	2	2	2	2
Cap, veh/h	266	51	56	200	71	80	28	1288	575	118	1467	654
Arrive On Green	0.13	0.13	0.13	0.13	0.13	0.13	0.02	0.36	0.36	0.07	0.41	0.41
Sat Flow, veh/h	790	400	446	454	562	635	1781	3554	1585	1781	3554	1585
Grp Volume(v), veh/h	88	0	0	117	0	0	12	755	31	63	825	40
Grp Sat Flow(s),veh/h/ln	1636	0	0	1650	0	0	1781	1777	1585	1781	1777	1585
Q Serve(g_s), s	0.0	0.0	0.0	0.6	0.0	0.0	0.2	5.8	0.4	1.2	6.0	0.5
Cycle Q Clear(g_c), s	1.5	0.0	0.0	2.1	0.0	0.0	0.2	5.8	0.4	1.2	6.0	0.5
Prop In Lane	0.56		0.27	0.33		0.38	1.00		1.00	1.00		1.00
Lane Grp Cap(c), veh/h	373	0	0	351	0	0	28	1288	575	118	1467	654
V/C Ratio(X)	0.24	0.00	0.00	0.33	0.00	0.00	0.43	0.59	0.05	0.54	0.56	0.06
Avail Cap(c_a), veh/h	968	0	0	991	0	0	264	2213	987	317	2319	1034
HCM Platoon Ratio	1.00	1.00	1.00	1.00	1.00	1.00	1.00	1.00	1.00	1.00	1.00	1.00
Upstream Filter(l)	1.00	0.00	0.00	1.00	0.00	0.00	1.00	1.00	1.00	1.00	1.00	1.00
Uniform Delay (d), s/veh	13.5	0.0	0.0	13.8	0.0	0.0	16.4	8.7	7.0	15.2	7.6	6.0
Incr Delay (d2), s/veh	0.3	0.0	0.0	0.6	0.0	0.0	10.0	0.4	0.0	3.7	0.3	0.0
Initial Q Delay(d3),s/veh	0.0	0.0	0.0	0.0	0.0	0.0	0.0	0.0	0.0	0.0	0.0	0.0
%ile BackOfQ(50%),veh/ln	0.5	0.0	0.0	0.7	0.0	0.0	0.2	1.5	0.1	0.5	1.5	0.1
Unsig. Movement Delay, s/veh												
LnGrp Delay(d),s/veh	13.8	0.0	0.0	14.3	0.0	0.0	26.4	9.1	7.0	19.0	7.9	6.0
LnGrp LOS	B	A	A	B	A	A	C	A	A	B	A	A
Approach Vol, veh/h		88			117			798			928	
Approach Delay, s/veh		13.8			14.3			9.3			8.6	
Approach LOS		B			B			A			A	
Timer - Assigned Phs	1	2		4	5	6		8				
Phs Duration (G+Y+Rc), s	7.2	17.2		9.3	5.5	18.9		9.3				
Change Period (Y+Rc), s	5.0	5.0		5.0	5.0	5.0		5.0				
Max Green Setting (Gmax), s	6.0	21.0		18.0	5.0	22.0		18.0				
Max Q Clear Time (g_c+I1), s	3.2	7.8		3.5	2.2	8.0		4.1				
Green Ext Time (p_c), s	0.0	4.4		0.3	0.0	5.0		0.4				
Intersection Summary												
HCM 6th Ctrl Delay				9.5								
HCM 6th LOS				A								

Intersection												
Int Delay, s/veh	0.4											
Movement	EBL	EBT	EBR	WBL	WBT	WBR	NBL	NBT	NBR	SBL	SBT	SBR
Lane Configurations		↕			↕		↕	↕		↕	↕	
Traffic Vol, veh/h	7	4	0	8	0	6	1	713	8	7	772	19
Future Vol, veh/h	7	4	0	8	0	6	1	713	8	7	772	19
Conflicting Peds, #/hr	0	0	0	0	0	0	0	0	0	0	0	0
Sign Control	Stop	Stop	Stop	Stop	Stop	Stop	Free	Free	Free	Free	Free	Free
RT Channelized	-	-	None	-	-	None	-	-	None	-	-	None
Storage Length	-	-	-	-	-	-	50	-	-	50	-	-
Veh in Median Storage, #	-	1	-	-	1	-	-	0	-	-	0	-
Grade, %	-	0	-	-	0	-	-	0	-	-	0	-
Peak Hour Factor	92	92	92	92	92	92	92	92	92	92	92	92
Heavy Vehicles, %	2	2	2	2	2	2	2	2	2	2	2	2
Mvmt Flow	8	4	0	9	0	7	1	775	9	8	839	21

Major/Minor	Minor2		Minor1		Major1			Major2				
Conflicting Flow All	1256	1652	430	1220	1658	392	860	0	0	784	0	0
Stage 1	866	866	-	782	782	-	-	-	-	-	-	-
Stage 2	390	786	-	438	876	-	-	-	-	-	-	-
Critical Hdwy	7.54	6.54	6.94	7.54	6.54	6.94	4.14	-	-	4.14	-	-
Critical Hdwy Stg 1	6.54	5.54	-	6.54	5.54	-	-	-	-	-	-	-
Critical Hdwy Stg 2	6.54	5.54	-	6.54	5.54	-	-	-	-	-	-	-
Follow-up Hdwy	3.52	4.02	3.32	3.52	4.02	3.32	2.22	-	-	2.22	-	-
Pot Cap-1 Maneuver	128	98	573	136	97	607	777	-	-	830	-	-
Stage 1	314	369	-	353	403	-	-	-	-	-	-	-
Stage 2	606	401	-	567	365	-	-	-	-	-	-	-
Platoon blocked, %								-	-	-	-	-
Mov Cap-1 Maneuver	126	97	573	133	96	607	777	-	-	830	-	-
Mov Cap-2 Maneuver	237	217	-	253	217	-	-	-	-	-	-	-
Stage 1	314	365	-	353	403	-	-	-	-	-	-	-
Stage 2	599	401	-	555	361	-	-	-	-	-	-	-

Approach	EB		WB		NB		SB	
HCM Control Delay, s	21.6		16.2		0		0.1	
HCM LOS	C		C					

Minor Lane/Major Mvmt	NBL	NBT	NBR	EBLn1WBLn1	SBL	SBT	SBR
Capacity (veh/h)	777	-	-	229	337	830	-
HCM Lane V/C Ratio	0.001	-	-	0.052	0.045	0.009	-
HCM Control Delay (s)	9.6	-	-	21.6	16.2	9.4	-
HCM Lane LOS	A	-	-	C	C	A	-
HCM 95th %tile Q(veh)	0	-	-	0.2	0.1	0	-

Heritage at Dalia Ranch
3: Imperial Ave & Ralph Rd

Opening Year 2028 + P1-4 Proj
Timing Plan: PM PEAK

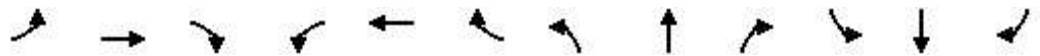

Movement	EBL	EBT	EBR	WBL	WBT	WBR	NBL	NBT	NBR	SBL	SBT	SBR
Lane Configurations												
Traffic Volume (veh/h)	81	22	90	58	18	23	192	621	96	53	629	84
Future Volume (veh/h)	81	22	90	58	18	23	192	621	96	53	629	84
Initial Q (Qb), veh	0	0	0	0	0	0	0	0	0	0	0	0
Ped-Bike Adj(A_pbT)	1.00		1.00	1.00		1.00	1.00		1.00	1.00		1.00
Parking Bus, Adj	1.00	1.00	1.00	1.00	1.00	1.00	1.00	1.00	1.00	1.00	1.00	1.00
Work Zone On Approach		No			No			No			No	
Adj Sat Flow, veh/h/ln	1870	1870	1870	1870	1870	1870	1870	1870	1870	1870	1870	1870
Adj Flow Rate, veh/h	88	24	98	64	20	25	209	682	105	58	691	91
Peak Hour Factor	0.92	0.92	0.92	0.91	0.92	0.91	0.92	0.91	0.91	0.91	0.91	0.92
Percent Heavy Veh, %	2	2	2	2	2	2	2	2	2	2	2	2
Cap, veh/h	173	38	153	166	85	106	213	1039	160	98	968	432
Arrive On Green	0.10	0.12	0.12	0.09	0.11	0.11	0.12	0.34	0.34	0.06	0.27	0.27
Sat Flow, veh/h	1781	321	1313	1781	756	945	1781	3087	475	1781	3554	1585
Grp Volume(v), veh/h	88	0	122	64	0	45	209	392	395	58	691	91
Grp Sat Flow(s),veh/h/ln	1781	0	1634	1781	0	1700	1781	1777	1785	1781	1777	1585
Q Serve(g_s), s	2.4	0.0	3.6	1.7	0.0	1.2	5.9	9.4	9.5	1.6	8.8	2.2
Cycle Q Clear(g_c), s	2.4	0.0	3.6	1.7	0.0	1.2	5.9	9.4	9.5	1.6	8.8	2.2
Prop In Lane	1.00		0.80	1.00		0.56	1.00		0.27	1.00		1.00
Lane Grp Cap(c), veh/h	173	0	191	166	0	192	213	598	601	98	968	432
V/C Ratio(X)	0.51	0.00	0.64	0.39	0.00	0.23	0.98	0.66	0.66	0.59	0.71	0.21
Avail Cap(c_a), veh/h	638	0	585	638	0	609	213	672	675	177	1273	568
HCM Platoon Ratio	1.00	1.00	1.00	1.00	1.00	1.00	1.00	1.00	1.00	1.00	1.00	1.00
Upstream Filter(l)	1.00	0.00	1.00	1.00	0.00	1.00	1.00	1.00	1.00	1.00	1.00	1.00
Uniform Delay (d), s/veh	21.5	0.0	21.2	21.4	0.0	20.3	22.1	14.2	14.2	23.2	16.5	14.1
Incr Delay (d2), s/veh	2.3	0.0	3.5	1.5	0.0	0.6	56.5	2.0	2.0	5.5	1.3	0.2
Initial Q Delay(d3),s/veh	0.0	0.0	0.0	0.0	0.0	0.0	0.0	0.0	0.0	0.0	0.0	0.0
%ile BackOfQ(50%),veh/ln	1.0	0.0	1.4	0.7	0.0	0.5	5.6	3.5	3.6	0.8	3.3	0.7
Unsig. Movement Delay, s/veh												
LnGrp Delay(d),s/veh	23.8	0.0	24.7	22.9	0.0	20.9	78.5	16.1	16.2	28.7	17.8	14.3
LnGrp LOS	C	A	C	C	A	C	E	B	B	C	B	B
Approach Vol, veh/h		210			109			996			840	
Approach Delay, s/veh		24.3			22.1			29.2			18.2	
Approach LOS		C			C			C			B	
Timer - Assigned Phs	1	2	3	4	5	6	7	8				
Phs Duration (G+Y+Rc), s	7.8	21.9	9.7	10.9	11.0	18.7	9.9	10.7				
Change Period (Y+Rc), s	5.0	5.0	5.0	5.0	5.0	5.0	5.0	5.0				
Max Green Setting (Gmax), s	5.0	19.0	18.0	18.0	6.0	18.0	18.0	18.0				
Max Q Clear Time (g_c+I1), s	3.6	11.5	3.7	5.6	7.9	10.8	4.4	3.2				
Green Ext Time (p_c), s	0.0	3.0	0.1	0.5	0.0	2.9	0.1	0.1				
Intersection Summary												
HCM 6th Ctrl Delay			24.1									
HCM 6th LOS			C									

Heritage at Dalia Ranch
4: Imperial Ave & Neckel Rd

Opening Year 2028 + P1-4 Proj
Timing Plan: PM PEAK



Movement	EBL	EBT	EBR	WBL	WBT	WBR	NBL	NBT	NBR	SBL	SBT	SBR
Lane Configurations		↕			↕		↕	↕		↕	↕	
Traffic Volume (veh/h)	13	28	90	141	21	86	159	834	180	83	723	30
Future Volume (veh/h)	13	28	90	141	21	86	159	834	180	83	723	30
Initial Q (Qb), veh	0	0	0	0	0	0	0	0	0	0	0	0
Ped-Bike Adj(A_pbT)	1.00		1.00	1.00		1.00	1.00		1.00	1.00		1.00
Parking Bus, Adj	1.00	1.00	1.00	1.00	1.00	1.00	1.00	1.00	1.00	1.00	1.00	1.00
Work Zone On Approach		No			No			No			No	
Adj Sat Flow, veh/h/ln	1870	1870	1870	1870	1870	1870	1870	1870	1870	1870	1870	1870
Adj Flow Rate, veh/h	14	30	98	153	23	93	173	907	196	90	786	33
Peak Hour Factor	0.92	0.92	0.92	0.92	0.92	0.92	0.92	0.92	0.92	0.92	0.92	0.92
Percent Heavy Veh, %	2	2	2	2	2	2	2	2	2	2	2	2
Cap, veh/h	18	40	129	189	28	115	144	890	192	115	1009	42
Arrive On Green	0.11	0.11	0.11	0.19	0.19	0.19	0.08	0.31	0.31	0.06	0.29	0.29
Sat Flow, veh/h	163	350	1143	975	147	593	1781	2907	628	1781	3475	146
Grp Volume(v), veh/h	142	0	0	269	0	0	173	554	549	90	402	417
Grp Sat Flow(s),veh/h/ln	1656	0	0	1715	0	0	1781	1777	1757	1781	1777	1844
Q Serve(g_s), s	5.2	0.0	0.0	9.3	0.0	0.0	5.0	19.0	19.0	3.1	12.9	12.9
Cycle Q Clear(g_c), s	5.2	0.0	0.0	9.3	0.0	0.0	5.0	19.0	19.0	3.1	12.9	12.9
Prop In Lane	0.10		0.69	0.57		0.35	1.00		0.36	1.00		0.08
Lane Grp Cap(c), veh/h	187	0	0	332	0	0	144	544	538	115	516	535
V/C Ratio(X)	0.76	0.00	0.00	0.81	0.00	0.00	1.21	1.02	1.02	0.78	0.78	0.78
Avail Cap(c_a), veh/h	481	0	0	497	0	0	144	544	538	144	544	565
HCM Platoon Ratio	1.00	1.00	1.00	1.00	1.00	1.00	1.00	1.00	1.00	1.00	1.00	1.00
Upstream Filter(l)	1.00	0.00	0.00	1.00	0.00	0.00	1.00	1.00	1.00	1.00	1.00	1.00
Uniform Delay (d), s/veh	26.7	0.0	0.0	23.9	0.0	0.0	28.5	21.5	21.5	28.6	20.2	20.2
Incr Delay (d2), s/veh	6.2	0.0	0.0	6.0	0.0	0.0	140.7	43.4	43.9	19.4	6.8	6.6
Initial Q Delay(d3),s/veh	0.0	0.0	0.0	0.0	0.0	0.0	0.0	0.0	0.0	0.0	0.0	0.0
%ile BackOfQ(50%),veh/ln	2.2	0.0	0.0	4.1	0.0	0.0	7.6	13.7	13.6	1.9	5.8	6.0
Unsig. Movement Delay, s/veh												
LnGrp Delay(d),s/veh	32.9	0.0	0.0	29.9	0.0	0.0	169.2	64.9	65.4	48.0	27.0	26.8
LnGrp LOS	C	A	A	C	A	A	F	F	F	D	C	C
Approach Vol, veh/h		142		269			1276			909		
Approach Delay, s/veh		32.9		29.9			79.2			29.0		
Approach LOS		C		C			E			C		
Timer - Assigned Phs	1	2		4	5	6		8				
Phs Duration (G+Y+Rc), s	9.0	24.0		12.0	10.0	23.0		17.0				
Change Period (Y+Rc), s	5.0	5.0		5.0	5.0	5.0		5.0				
Max Green Setting (Gmax), s	5.0	19.0		18.0	5.0	19.0		18.0				
Max Q Clear Time (g_c+1/2), s	15.0	21.0		7.2	7.0	14.9		11.3				
Green Ext Time (p_c), s	0.0	0.0		0.5	0.0	1.9		0.8				

Intersection Summary

HCM 6th Ctrl Delay	54.0
HCM 6th LOS	D

Intersection												
Int Delay, s/veh	10.3											
Movement	EBL	EBT	EBR	WBL	WBT	WBR	NBL	NBT	NBR	SBL	SBT	SBR
Lane Configurations		↕			↕			↕			↕	
Traffic Vol, veh/h	2	41	9	29	47	193	6	50	19	146	42	8
Future Vol, veh/h	2	41	9	29	47	193	6	50	19	146	42	8
Conflicting Peds, #/hr	0	0	0	0	0	0	0	0	0	0	0	0
Sign Control	Stop	Stop	Stop	Stop	Stop	Stop	Free	Free	Free	Free	Free	Free
RT Channelized	-	-	None	-	-	None	-	-	None	-	-	None
Storage Length	-	-	-	-	-	-	-	-	-	-	-	-
Veh in Median Storage, #	-	0	-	-	0	-	-	0	-	-	0	-
Grade, %	-	0	-	-	0	-	-	0	-	-	0	-
Peak Hour Factor	79	79	79	79	79	79	79	79	79	79	79	79
Heavy Vehicles, %	2	2	2	2	2	2	2	2	2	2	2	2
Mvmt Flow	3	52	11	37	59	244	8	63	24	185	53	10

Major/Minor	Minor2		Minor1		Major1		Major2					
Conflicting Flow All	671	531	58	551	524	75	63	0	0	87	0	0
Stage 1	428	428	-	91	91	-	-	-	-	-	-	-
Stage 2	243	103	-	460	433	-	-	-	-	-	-	-
Critical Hdwy	7.12	6.52	6.22	7.12	6.52	6.22	4.12	-	-	4.12	-	-
Critical Hdwy Stg 1	6.12	5.52	-	6.12	5.52	-	-	-	-	-	-	-
Critical Hdwy Stg 2	6.12	5.52	-	6.12	5.52	-	-	-	-	-	-	-
Follow-up Hdwy	3.518	4.018	3.318	3.518	4.018	3.318	2.218	-	-	2.218	-	-
Pot Cap-1 Maneuver	370	454	1008	445	458	986	1540	-	-	1509	-	-
Stage 1	605	585	-	916	820	-	-	-	-	-	-	-
Stage 2	761	810	-	581	582	-	-	-	-	-	-	-
Platoon blocked, %								-	-	-	-	-
Mov Cap-1 Maneuver	222	395	1008	356	398	986	1540	-	-	1509	-	-
Mov Cap-2 Maneuver	222	395	-	356	398	-	-	-	-	-	-	-
Stage 1	602	511	-	911	816	-	-	-	-	-	-	-
Stage 2	528	806	-	451	508	-	-	-	-	-	-	-

Approach	EB	WB	NB	SB
HCM Control Delay, s	15	15.5	0.6	5.7
HCM LOS	C	C		

Minor Lane/Major Mvmt	NBL	NBT	NBR	EBLn1WBLn1	SBL	SBT	SBR
Capacity (veh/h)	1540	-	-	427	681	1509	-
HCM Lane V/C Ratio	0.005	-	-	0.154	0.5	0.122	-
HCM Control Delay (s)	7.3	0	-	15	15.5	7.7	0
HCM Lane LOS	A	A	-	C	C	A	A
HCM 95th %tile Q(veh)	0	-	-	0.5	2.8	0.4	-

Heritage at Dalia Ranch
6: Imperial Ave & Worthington Rd/Barioni Blvd

Opening Year 2028 + P1-4 Proj
Timing Plan: PM PEAK

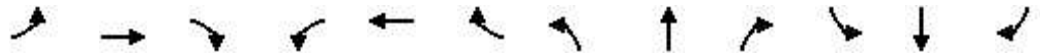

Movement	EBL	EBT	EBR	WBL	WBT	WBR	NBL	NBT	NBR	SBL	SBT	SBR
Lane Configurations		↕	↗		↕	↗	↗	↕↗		↗	↕↗	
Traffic Volume (veh/h)	78	79	112	58	120	107	120	1114	15	70	910	82
Future Volume (veh/h)	78	79	112	58	120	107	120	1114	15	70	910	82
Initial Q (Qb), veh	0	0	0	0	0	0	0	0	0	0	0	0
Ped-Bike Adj(A_pbT)	1.00		1.00	1.00		1.00	1.00		1.00	1.00		1.00
Parking Bus, Adj	1.00	1.00	1.00	1.00	1.00	1.00	1.00	1.00	1.00	1.00	1.00	1.00
Work Zone On Approach		No			No			No			No	
Adj Sat Flow, veh/h/ln	1870	1870	1870	1870	1870	1870	1870	1870	1870	1870	1870	1870
Adj Flow Rate, veh/h	86	87	123	64	132	118	132	1224	16	77	1000	90
Peak Hour Factor	0.91	0.91	0.91	0.91	0.91	0.91	0.91	0.91	0.91	0.91	0.91	0.91
Percent Heavy Veh, %	2	2	2	2	2	2	2	2	2	2	2	2
Cap, veh/h	119	121	209	86	178	227	166	1397	18	99	1157	104
Arrive On Green	0.13	0.13	0.13	0.14	0.14	0.14	0.09	0.39	0.39	0.06	0.35	0.35
Sat Flow, veh/h	907	918	1585	601	1239	1585	1781	3592	47	1781	3297	297
Grp Volume(v), veh/h	173	0	123	196	0	118	132	605	635	77	539	551
Grp Sat Flow(s),veh/h/ln	1825	0	1585	1840	0	1585	1781	1777	1862	1781	1777	1817
Q Serve(g_s), s	6.5	0.0	5.2	7.3	0.0	4.9	5.2	22.5	22.5	3.0	20.1	20.1
Cycle Q Clear(g_c), s	6.5	0.0	5.2	7.3	0.0	4.9	5.2	22.5	22.5	3.0	20.1	20.1
Prop In Lane	0.50		1.00	0.33		1.00	1.00		0.03	1.00		0.16
Lane Grp Cap(c), veh/h	240	0	209	264	0	227	166	691	724	99	624	638
V/C Ratio(X)	0.72	0.00	0.59	0.74	0.00	0.52	0.79	0.88	0.88	0.78	0.86	0.86
Avail Cap(c_a), veh/h	461	0	400	465	0	400	175	723	758	125	673	688
HCM Platoon Ratio	1.00	1.00	1.00	1.00	1.00	1.00	1.00	1.00	1.00	1.00	1.00	1.00
Upstream Filter(I)	1.00	0.00	1.00	1.00	0.00	1.00	1.00	1.00	1.00	1.00	1.00	1.00
Uniform Delay (d), s/veh	29.7	0.0	29.1	29.3	0.0	28.2	31.6	20.2	20.2	33.2	21.5	21.5
Incr Delay (d2), s/veh	4.0	0.0	2.6	4.1	0.0	1.8	21.0	11.4	11.0	21.3	10.7	10.5
Initial Q Delay(d3),s/veh	0.0	0.0	0.0	0.0	0.0	0.0	0.0	0.0	0.0	0.0	0.0	0.0
%ile BackOfQ(50%),veh/ln	3.0	0.0	2.1	3.4	0.0	1.9	3.1	10.6	11.1	1.9	9.6	9.8
Unsig. Movement Delay, s/veh												
LnGrp Delay(d),s/veh	33.7	0.0	31.8	33.4	0.0	30.1	52.7	31.6	31.2	54.6	32.2	32.1
LnGrp LOS	C	A	C	C	A	C	D	C	C	D	C	C
Approach Vol, veh/h		296			314			1372			1167	
Approach Delay, s/veh		32.9			32.1			33.4			33.6	
Approach LOS		C			C			C			C	
Timer - Assigned Phs	1	2		4	5	6		8				
Phs Duration (G+Y+Rc), s	8.9	32.7		14.4	11.6	30.0		15.2				
Change Period (Y+Rc), s	5.0	5.0		5.0	5.0	5.0		5.0				
Max Green Setting (Gmax), s	5.0	29.0		18.0	7.0	27.0		18.0				
Max Q Clear Time (g_c+I1), s	5.0	24.5		8.5	7.2	22.1		9.3				
Green Ext Time (p_c), s	0.0	3.0		0.9	0.0	2.9		1.0				
Intersection Summary												
HCM 6th Ctrl Delay			33.3									
HCM 6th LOS			C									

Heritage at Dalia Ranch
7: La Brucherie Rd & Worthington Rd

Opening Year 2028 + P1-4 Proj
Timing Plan: PM PEAK

Intersection												
Intersection Delay, s/veh	13.3											
Intersection LOS	B											

Movement	EBL	EBT	EBR	WBL	WBT	WBR	NBL	NBT	NBR	SBL	SBT	SBR
Lane Configurations		↔	↔		↔	↔		↔			↔	
Traffic Vol, veh/h	80	227	35	29	245	36	1	0	0	40	6	66
Future Vol, veh/h	80	227	35	29	245	36	1	0	0	40	6	66
Peak Hour Factor	0.80	0.80	0.80	0.80	0.80	0.80	0.80	0.80	0.80	0.80	0.80	0.80
Heavy Vehicles, %	2	2	2	2	2	2	2	2	2	2	2	2
Mvmt Flow	100	284	44	36	306	45	1	0	0	50	8	83
Number of Lanes	0	1	1	0	1	1	0	1	0	0	1	0

Approach	EB	WB	NB	SB
Opposing Approach	WB	EB	SB	NB
Opposing Lanes	2	2	1	1
Conflicting Approach Left	SB	NB	EB	WB
Conflicting Lanes Left	1	1	2	2
Conflicting Approach Right	NB	SB	WB	EB
Conflicting Lanes Right	1	1	2	2
HCM Control Delay	14.6	13.1	9.5	10.2
HCM LOS	B	B	A	B

Lane	NBLn1	EBLn1	EBLn2	WBLn1	WBLn2	SBLn1
Vol Left, %	100%	26%	0%	11%	0%	36%
Vol Thru, %	0%	74%	0%	89%	0%	5%
Vol Right, %	0%	0%	100%	0%	100%	59%
Sign Control	Stop	Stop	Stop	Stop	Stop	Stop
Traffic Vol by Lane	1	307	35	274	36	112
LT Vol	1	80	0	29	0	40
Through Vol	0	227	0	245	0	6
RT Vol	0	0	35	0	36	66
Lane Flow Rate	1	384	44	342	45	140
Geometry Grp	2	7	7	7	7	2
Degree of Util (X)	0.002	0.577	0.056	0.512	0.058	0.215
Departure Headway (Hd)	6.479	5.417	4.58	5.381	4.622	5.54
Convergence, Y/N	Yes	Yes	Yes	Yes	Yes	Yes
Cap	556	660	774	664	766	641
Service Time	4.479	3.197	2.359	3.163	2.403	3.634
HCM Lane V/C Ratio	0.002	0.582	0.057	0.515	0.059	0.218
HCM Control Delay	9.5	15.4	7.6	13.8	7.7	10.2
HCM Lane LOS	A	C	A	B	A	B
HCM 95th-tile Q	0	3.7	0.2	2.9	0.2	0.8

Heritage at Dalia Ranch
8: Imperial Ave & Aten Rd

Opening Year 2028 + P1-4 Proj
Timing Plan: PM PEAK



Movement	EBL	EBT	EBR	WBL	WBT	WBR	NBL	NBT	NBR	SBL	SBT	SBR
Lane Configurations												
Traffic Volume (veh/h)	281	295	73	191	309	183	84	982	160	161	755	280
Future Volume (veh/h)	281	295	73	191	309	183	84	982	160	161	755	280
Initial Q (Qb), veh	0	0	0	0	0	0	0	0	0	0	0	0
Ped-Bike Adj(A_pbT)	1.00		1.00	1.00		1.00	1.00		1.00	1.00		1.00
Parking Bus, Adj	1.00	1.00	1.00	1.00	1.00	1.00	1.00	1.00	1.00	1.00	1.00	1.00
Work Zone On Approach		No			No			No			No	
Adj Sat Flow, veh/h/ln	1870	1870	1870	1870	1870	1870	1870	1870	1870	1870	1870	1870
Adj Flow Rate, veh/h	299	314	78	203	329	195	89	1045	170	171	803	298
Peak Hour Factor	0.94	0.94	0.94	0.94	0.94	0.94	0.94	0.94	0.94	0.94	0.94	0.94
Percent Heavy Veh, %	2	2	2	2	2	2	2	2	2	2	2	2
Cap, veh/h	276	608	149	245	428	248	114	951	424	176	1073	479
Arrive On Green	0.15	0.21	0.21	0.14	0.20	0.20	0.06	0.27	0.27	0.10	0.30	0.30
Sat Flow, veh/h	1781	2830	693	1781	2165	1256	1781	3554	1585	1781	3554	1585
Grp Volume(v), veh/h	299	195	197	203	269	255	89	1045	170	171	803	298
Grp Sat Flow(s),veh/h/ln	1781	1777	1746	1781	1777	1644	1781	1777	1585	1781	1777	1585
Q Serve(g_s), s	11.0	6.9	7.1	7.9	10.2	10.5	3.5	19.0	6.3	6.8	14.5	11.5
Cycle Q Clear(g_c), s	11.0	6.9	7.1	7.9	10.2	10.5	3.5	19.0	6.3	6.8	14.5	11.5
Prop In Lane	1.00		0.40	1.00		0.76	1.00		1.00	1.00		1.00
Lane Grp Cap(c), veh/h	276	382	375	245	351	325	114	951	424	176	1073	479
V/C Ratio(X)	1.08	0.51	0.52	0.83	0.77	0.79	0.78	1.10	0.40	0.97	0.75	0.62
Avail Cap(c_a), veh/h	276	450	442	276	450	417	150	951	424	176	1073	479
HCM Platoon Ratio	1.00	1.00	1.00	1.00	1.00	1.00	1.00	1.00	1.00	1.00	1.00	1.00
Upstream Filter(l)	1.00	1.00	1.00	1.00	1.00	1.00	1.00	1.00	1.00	1.00	1.00	1.00
Uniform Delay (d), s/veh	30.0	24.6	24.7	29.8	26.9	27.1	32.7	26.0	21.3	31.9	22.4	21.3
Incr Delay (d2), s/veh	78.3	1.1	1.1	17.1	5.8	7.4	17.1	60.2	0.6	60.1	2.9	2.5
Initial Q Delay(d3),s/veh	0.0	0.0	0.0	0.0	0.0	0.0	0.0	0.0	0.0	0.0	0.0	0.0
%ile BackOfQ(50%),veh/ft	0.5	2.9	2.9	4.4	4.7	4.6	2.0	15.5	2.3	5.8	6.1	4.3
Unsig. Movement Delay, s/veh												
LnGrp Delay(d),s/veh	108.4	25.7	25.8	46.9	32.8	34.5	49.8	86.2	22.0	92.0	25.3	23.8
LnGrp LOS	F	C	C	D	C	C	D	F	C	F	C	C
Approach Vol, veh/h		691			727			1304			1272	
Approach Delay, s/veh		61.5			37.3			75.4			33.9	
Approach LOS		E			D			E			C	
Timer - Assigned Phs	1	2	3	4	5	6	7	8				
Phs Duration (G+Y+Rc), s	24.0	24.0	14.8	20.3	9.6	26.4	16.0	19.0				
Change Period (Y+Rc), s	5.0	5.0	5.0	5.0	5.0	5.0	5.0	5.0				
Max Green Setting (Gmax), s	19.0	19.0	11.0	18.0	6.0	20.0	11.0	18.0				
Max Q Clear Time (g_c+1/3), s	21.0	21.0	9.9	9.1	5.5	16.5	13.0	12.5				
Green Ext Time (p_c), s	0.0	0.0	0.1	1.5	0.0	2.1	0.0	1.6				
Intersection Summary												
HCM 6th Ctrl Delay											52.8	
HCM 6th LOS											D	

Intersection						
Int Delay, s/veh	1.3					
Movement	EBL	EBT	WBT	WBR	SBL	SBR
Lane Configurations	↖	↗	↖		↖	↗
Traffic Vol, veh/h	8	97	151	59	34	5
Future Vol, veh/h	8	97	151	59	34	5
Conflicting Peds, #/hr	0	0	0	0	0	0
Sign Control	Free	Free	Free	Free	Stop	Stop
RT Channelized	-	None	-	None	-	None
Storage Length	50	-	-	-	0	0
Veh in Median Storage, #	-	0	0	-	0	-
Grade, %	-	0	0	-	0	-
Peak Hour Factor	92	92	92	92	92	92
Heavy Vehicles, %	2	2	2	2	2	2
Mvmt Flow	9	105	164	64	37	5

Major/Minor	Major1	Major2	Minor2		
Conflicting Flow All	228	0	-	0	319
Stage 1	-	-	-	-	196
Stage 2	-	-	-	-	123
Critical Hdwy	4.12	-	-	-	6.42
Critical Hdwy Stg 1	-	-	-	-	5.42
Critical Hdwy Stg 2	-	-	-	-	5.42
Follow-up Hdwy	2.218	-	-	-	3.518
Pot Cap-1 Maneuver	1340	-	-	-	674
Stage 1	-	-	-	-	837
Stage 2	-	-	-	-	902
Platoon blocked, %		-	-	-	
Mov Cap-1 Maneuver	1340	-	-	-	669
Mov Cap-2 Maneuver	-	-	-	-	669
Stage 1	-	-	-	-	831
Stage 2	-	-	-	-	902

Approach	EB	WB	SB
HCM Control Delay, s	0.6	0	10.5
HCM LOS			B

Minor Lane/Major Mvmt	EBL	EBT	WBT	WBR	SBLn1	SBLn2
Capacity (veh/h)	1340	-	-	-	669	845
HCM Lane V/C Ratio	0.006	-	-	-	0.055	0.006
HCM Control Delay (s)	7.7	-	-	-	10.7	9.3
HCM Lane LOS	A	-	-	-	B	A
HCM 95th %tile Q(veh)	0	-	-	-	0.2	0

Intersection												
Int Delay, s/veh	4.9											
Movement	EBL	EBT	EBR	WBL	WBT	WBR	NBL	NBT	NBR	SBL	SBT	SBR
Lane Configurations		↖	↗		↖	↗	↖	↗		↖	↗	
Traffic Vol, veh/h	15	0	59	5	0	0	101	48	8	0	51	25
Future Vol, veh/h	15	0	59	5	0	0	101	48	8	0	51	25
Conflicting Peds, #/hr	0	0	0	0	0	0	0	0	0	0	0	0
Sign Control	Stop	Stop	Stop	Stop	Stop	Stop	Free	Free	Free	Free	Free	Free
RT Channelized	-	-	None	-	-	None	-	-	None	-	-	None
Storage Length	-	-	0	-	-	0	0	-	-	50	-	-
Veh in Median Storage, #	-	0	-	-	0	-	-	0	-	-	0	-
Grade, %	-	0	-	-	0	-	-	0	-	-	0	-
Peak Hour Factor	92	92	92	92	92	92	92	92	92	92	92	92
Heavy Vehicles, %	2	2	2	2	2	2	2	2	2	2	2	2
Mvmt Flow	16	0	64	5	0	0	110	52	9	0	55	27

Major/Minor	Minor2		Minor1			Major1			Major2			
Conflicting Flow All	346	350	69	378	359	57	82	0	0	61	0	0
Stage 1	69	69	-	277	277	-	-	-	-	-	-	-
Stage 2	277	281	-	101	82	-	-	-	-	-	-	-
Critical Hdwy	7.12	6.52	6.22	7.12	6.52	6.22	4.12	-	-	4.12	-	-
Critical Hdwy Stg 1	6.12	5.52	-	6.12	5.52	-	-	-	-	-	-	-
Critical Hdwy Stg 2	6.12	5.52	-	6.12	5.52	-	-	-	-	-	-	-
Follow-up Hdwy	3.518	4.018	3.318	3.518	4.018	3.318	2.218	-	-	2.218	-	-
Pot Cap-1 Maneuver	608	574	994	580	568	1009	1515	-	-	1542	-	-
Stage 1	941	837	-	729	681	-	-	-	-	-	-	-
Stage 2	729	678	-	905	827	-	-	-	-	-	-	-
Platoon blocked, %								-	-	-	-	-
Mov Cap-1 Maneuver	574	532	994	513	527	1009	1515	-	-	1542	-	-
Mov Cap-2 Maneuver	574	532	-	513	527	-	-	-	-	-	-	-
Stage 1	872	837	-	676	631	-	-	-	-	-	-	-
Stage 2	676	629	-	847	827	-	-	-	-	-	-	-

Approach	EB		WB			NB			SB		
HCM Control Delay, s	9.4		12.1			4.9			0		
HCM LOS	A		B								

Minor Lane/Major Mvmt	NBL	NBT	NBR	EBLn1	EBLn2	WBLn1	WBLn2	SBL	SBT	SBR
Capacity (veh/h)	1515	-	-	574	994	513	-	1542	-	-
HCM Lane V/C Ratio	0.072	-	-	0.028	0.065	0.011	-	-	-	-
HCM Control Delay (s)	7.6	-	-	11.5	8.9	12.1	0	0	-	-
HCM Lane LOS	A	-	-	B	A	B	A	A	-	-
HCM 95th %tile Q(veh)	0.2	-	-	0.1	0.2	0	-	0	-	-

Intersection						
Int Delay, s/veh	4.4					
Movement	EBT	EBR	WBL	WBT	NBL	NBR
Lane Configurations	↔		↔	↑	↔	↔
Traffic Vol, veh/h	53	0	92	63	0	53
Future Vol, veh/h	53	0	92	63	0	53
Conflicting Peds, #/hr	0	0	0	0	0	0
Sign Control	Free	Free	Free	Free	Stop	Stop
RT Channelized	-	None	-	None	-	None
Storage Length	-	-	50	-	0	0
Veh in Median Storage, #	0	-	-	0	0	-
Grade, %	0	-	-	0	0	-
Peak Hour Factor	92	92	92	92	92	92
Heavy Vehicles, %	2	2	2	2	2	2
Mvmt Flow	58	0	100	68	0	58

Major/Minor	Major1	Major2	Minor1			
Conflicting Flow All	0	0	58	0	326	58
Stage 1	-	-	-	-	58	-
Stage 2	-	-	-	-	268	-
Critical Hdwy	-	-	4.12	-	6.42	6.22
Critical Hdwy Stg 1	-	-	-	-	5.42	-
Critical Hdwy Stg 2	-	-	-	-	5.42	-
Follow-up Hdwy	-	-	2.218	-	3.518	3.318
Pot Cap-1 Maneuver	-	-	1546	-	668	1008
Stage 1	-	-	-	-	965	-
Stage 2	-	-	-	-	777	-
Platoon blocked, %	-	-	-	-	-	-
Mov Cap-1 Maneuver	-	-	1546	-	625	1008
Mov Cap-2 Maneuver	-	-	-	-	625	-
Stage 1	-	-	-	-	965	-
Stage 2	-	-	-	-	726	-

Approach	EB	WB	NB
HCM Control Delay, s	0	4.4	8.8
HCM LOS			A

Minor Lane/Major Mvmt	NBLn1	NBLn2	EBT	EBR	WBL	WBT
Capacity (veh/h)	-	1008	-	-	1546	-
HCM Lane V/C Ratio	-	0.057	-	-	0.065	-
HCM Control Delay (s)	0	8.8	-	-	7.5	-
HCM Lane LOS	A	A	-	-	A	-
HCM 95th %tile Q(veh)	-	0.2	-	-	0.2	-

Intersection						
Int Delay, s/veh	1.3					
Movement	EBT	EBR	WBL	WBT	NBL	NBR
Lane Configurations	↔		↔	↑	↔	↔
Traffic Vol, veh/h	102	4	33	153	2	17
Future Vol, veh/h	102	4	33	153	2	17
Conflicting Peds, #/hr	0	0	0	0	0	0
Sign Control	Free	Free	Free	Free	Stop	Stop
RT Channelized	-	None	-	None	-	None
Storage Length	-	-	50	-	0	0
Veh in Median Storage, #	0	-	-	0	0	-
Grade, %	0	-	-	0	0	-
Peak Hour Factor	92	92	92	92	92	92
Heavy Vehicles, %	2	2	2	2	2	2
Mvmt Flow	111	4	36	166	2	18

Major/Minor	Major1	Major2	Minor1		
Conflicting Flow All	0	0	115	0	351 113
Stage 1	-	-	-	-	113 -
Stage 2	-	-	-	-	238 -
Critical Hdwy	-	-	4.12	-	6.42 6.22
Critical Hdwy Stg 1	-	-	-	-	5.42 -
Critical Hdwy Stg 2	-	-	-	-	5.42 -
Follow-up Hdwy	-	-	2.218	-	3.518 3.318
Pot Cap-1 Maneuver	-	-	1474	-	646 940
Stage 1	-	-	-	-	912 -
Stage 2	-	-	-	-	802 -
Platoon blocked, %	-	-	-	-	-
Mov Cap-1 Maneuver	-	-	1474	-	630 940
Mov Cap-2 Maneuver	-	-	-	-	630 -
Stage 1	-	-	-	-	912 -
Stage 2	-	-	-	-	783 -

Approach	EB	WB	NB
HCM Control Delay, s	0	1.3	9.1
HCM LOS			A

Minor Lane/Major Mvmt	NBLn1	NBLn2	EBT	EBR	WBL	WBT
Capacity (veh/h)	630	940	-	-	1474	-
HCM Lane V/C Ratio	0.003	0.02	-	-	0.024	-
HCM Control Delay (s)	10.7	8.9	-	-	7.5	-
HCM Lane LOS	B	A	-	-	A	-
HCM 95th %tile Q(veh)	0	0.1	-	-	0.1	-

Intersection						
Int Delay, s/veh	6.2					
Movement	EBT	EBR	WBL	WBT	NBL	NBR
Lane Configurations	↔		↔	↑	↔	↔
Traffic Vol, veh/h	85	34	270	150	36	180
Future Vol, veh/h	85	34	270	150	36	180
Conflicting Peds, #/hr	0	0	0	0	0	0
Sign Control	Free	Free	Free	Free	Stop	Stop
RT Channelized	-	None	-	None	-	None
Storage Length	-	-	100	-	0	0
Veh in Median Storage, #	0	-	-	0	0	-
Grade, %	0	-	-	0	0	-
Peak Hour Factor	92	92	92	92	92	92
Heavy Vehicles, %	2	2	2	2	2	2
Mvmt Flow	92	37	293	163	39	196

Major/Minor	Major1	Major2	Minor1		
Conflicting Flow All	0	0	129	0	860 111
Stage 1	-	-	-	-	111 -
Stage 2	-	-	-	-	749 -
Critical Hdwy	-	-	4.12	-	6.42 6.22
Critical Hdwy Stg 1	-	-	-	-	5.42 -
Critical Hdwy Stg 2	-	-	-	-	5.42 -
Follow-up Hdwy	-	-	2.218	-	3.518 3.318
Pot Cap-1 Maneuver	-	-	1457	-	326 942
Stage 1	-	-	-	-	914 -
Stage 2	-	-	-	-	467 -
Platoon blocked, %	-	-	-	-	-
Mov Cap-1 Maneuver	-	-	1457	-	260 942
Mov Cap-2 Maneuver	-	-	-	-	260 -
Stage 1	-	-	-	-	914 -
Stage 2	-	-	-	-	373 -

Approach	EB	WB	NB
HCM Control Delay, s	0	5.2	11.7
HCM LOS			B

Minor Lane/Major Mvmt	NBLn1	NBLn2	EBT	EBR	WBL	WBT
Capacity (veh/h)	260	942	-	-	1457	-
HCM Lane V/C Ratio	0.151	0.208	-	-	0.201	-
HCM Control Delay (s)	21.3	9.8	-	-	8.1	-
HCM Lane LOS	C	A	-	-	A	-
HCM 95th %tile Q(veh)	0.5	0.8	-	-	0.8	-

Intersection						
Int Delay, s/veh	1					
Movement	EBL	EBR	NBL	NBT	SBT	SBR
Lane Configurations		↗		↕↕	↕↕	↗
Traffic Vol, veh/h	0	144	0	922	721	34
Future Vol, veh/h	0	144	0	922	721	34
Conflicting Peds, #/hr	0	0	0	0	0	0
Sign Control	Stop	Stop	Free	Free	Free	Free
RT Channelized	-	None	-	None	-	None
Storage Length	-	0	-	-	-	100
Veh in Median Storage, #	0	-	-	0	0	-
Grade, %	0	-	-	0	0	-
Peak Hour Factor	92	92	92	92	92	92
Heavy Vehicles, %	2	2	2	2	2	2
Mvmt Flow	0	157	0	1002	784	37

Major/Minor	Minor2	Major1	Major2
Conflicting Flow All	-	392	0
Stage 1	-	-	-
Stage 2	-	-	-
Critical Hdwy	-	6.94	-
Critical Hdwy Stg 1	-	-	-
Critical Hdwy Stg 2	-	-	-
Follow-up Hdwy	-	3.32	-
Pot Cap-1 Maneuver	0	607	0
Stage 1	0	-	0
Stage 2	0	-	0
Platoon blocked, %			-
Mov Cap-1 Maneuver	-	607	-
Mov Cap-2 Maneuver	-	-	-
Stage 1	-	-	-
Stage 2	-	-	-

Approach	EB	NB	SB
HCM Control Delay, s	13	0	0
HCM LOS	B		

Minor Lane/Major Mvmt	NBT	EBLn1	SBT	SBR
Capacity (veh/h)	-	607	-	-
HCM Lane V/C Ratio	-	0.258	-	-
HCM Control Delay (s)	-	13	-	-
HCM Lane LOS	-	B	-	-
HCM 95th %tile Q(veh)	-	1	-	-

Appendix D

Internal Capture Worksheets

NCHRP 684 Internal Trip Capture Estimation Tool					
Project Name:	Heritage at Dalia Ranch			Organization:	Mizuta Traffic
Project Location:	Imperial, CA			Performed By:	MTC
Scenario Description:	n/a			Date:	17-Nov
Analysis Year:	n/a			Checked By:	MTC
Analysis Period:	AM Street Peak Hour			Date:	17-Nov

Table 1-A: Base Vehicle-Trip Generation Estimates (Single-Use Site Estimate)						
Land Use	Development Data (For Information Only)			Estimated Vehicle-Trips ³		
	ITE LUCs ¹	Quantity	Units	Total	Entering	Exiting
Office				93	73	20
Retail				77	47	30
Restaurant				193	99	94
Cinema/Entertainment				0		
Residential				198	50	148
Hotel				0		
All Other Land Uses ²				321	172	149
				882	441	441

Table 2-A: Mode Split and Vehicle Occupancy Estimates						
Land Use	Entering Trips			Exiting Trips		
	Veh. Occ. ⁴	% Transit	% Non-Motorized	Veh. Occ. ⁴	% Transit	% Non-Motorized
Office						
Retail						
Restaurant						
Cinema/Entertainment						
Residential						
Hotel						
All Other Land Uses ²						

Table 3-A: Average Land Use Interchange Distances (Feet Walking Distance)						
Origin (From)	Destination (To)					
	Office	Retail	Restaurant	Cinema/Entertainment	Residential	Hotel
Office						
Retail						
Restaurant						
Cinema/Entertainment						
Residential						
Hotel						

Table 4-A: Internal Person-Trip Origin-Destination Matrix*						
Origin (From)	Destination (To)					
	Office	Retail	Restaurant	Cinema/Entertainment	Residential	Hotel
Office		6	13	0	0	0
Retail	3		4	0	1	0
Restaurant	10	4		0	3	0
Cinema/Entertainment	0	0	0		0	0
Residential	2	1	20	0		0
Hotel	0	0	0	0	0	

Table 5-A: Computations Summary			
	Total	Entering	Exiting
All Person-Trips	882	441	441
Internal Capture Percentage	15%	15%	15%
External Vehicle-Trips ⁵	748	374	374
External Transit-Trips ⁶	0	0	0
External Non-Motorized Trips ⁶	0	0	0

Table 6-A: Internal Trip Capture Percentages by Land Use		
Land Use	Entering Trips	Exiting Trips
Office	21%	95%
Retail	23%	27%
Restaurant	37%	18%
Cinema/Entertainment	N/A	N/A
Residential	8%	16%
Hotel	N/A	N/A

¹Land Use Codes (LUCs) from *Trip Generation Manual*, published by the Institute of Transportation Engineers.

²Total estimate for all other land uses at mixed-use development site is not subject to internal trip capture computations in this estimator.

³Enter trips assuming no transit or non-motorized trips (as assumed in ITE *Trip Generation Manual*).

⁴Enter vehicle occupancy assumed in Table 1-A vehicle trips. If vehicle occupancy changes for proposed mixed-use project, manual adjustments must be made to Tables 5-A, 9-A (O and D). Enter transit, non-motorized percentages that will result with proposed mixed-use project complete.

⁵Vehicle-trips computed using the mode split and vehicle occupancy values provided in Table 2-A.

⁶Person-Trips

*Indicates computation that has been rounded to the nearest whole number.

Estimation Tool Developed by the Texas A&M Transportation Institute - Version 2013.1

Project Name:	Heritage at Dalia Ranch
Analysis Period:	AM Street Peak Hour

Land Use	Table 7-A (D): Entering Trips			Table 7-A (O): Exiting Trips		
	Veh. Occ.	Vehicle-Trips	Person-Trips*	Veh. Occ.	Vehicle-Trips	Person-Trips*
Office	1.00	73	73	1.00	20	20
Retail	1.00	47	47	1.00	30	30
Restaurant	1.00	99	99	1.00	94	94
Cinema/Entertainment	1.00	0	0	1.00	0	0
Residential	1.00	50	50	1.00	148	148
Hotel	1.00	0	0	1.00	0	0

Origin (From)	Destination (To)					
	Office	Retail	Restaurant	Cinema/Entertainment	Residential	Hotel
Office		6	13	0	0	0
Retail	9		4	0	4	0
Restaurant	29	13		0	4	3
Cinema/Entertainment	0	0	0		0	0
Residential	3	1	30	0		0
Hotel	0	0	0	0	0	

Origin (From)	Destination (To)					
	Office	Retail	Restaurant	Cinema/Entertainment	Residential	Hotel
Office		15	23	0	0	0
Retail	3		50	0	1	0
Restaurant	10	4		0	3	0
Cinema/Entertainment	0	0	0		0	0
Residential	2	8	20	0		0
Hotel	2	2	6	0	0	

Destination Land Use	Person-Trip Estimates			External Trips by Mode*		
	Internal	External	Total	Vehicles ¹	Transit ²	Non-Motorized ²
Office	15	58	73	58	0	0
Retail	11	36	47	36	0	0
Restaurant	37	62	99	62	0	0
Cinema/Entertainment	0	0	0	0	0	0
Residential	4	46	50	46	0	0
Hotel	0	0	0	0	0	0
All Other Land Uses ³	0	172	172	172	0	0

Origin Land Use	Person-Trip Estimates			External Trips by Mode*		
	Internal	External	Total	Vehicles ¹	Transit ²	Non-Motorized ²
Office	19	1	20	1	0	0
Retail	8	22	30	22	0	0
Restaurant	17	77	94	77	0	0
Cinema/Entertainment	0	0	0	0	0	0
Residential	23	125	148	125	0	0
Hotel	0	0	0	0	0	0
All Other Land Uses ³	0	149	149	149	0	0

¹Vehicle-trips computed using the mode split and vehicle occupancy values provided in Table 2-A
²Person-Trips
³Total estimate for all other land uses at mixed-use development site is not subject to internal trip capture computations in this estimator
*Indicates computation that has been rounded to the nearest whole number.

NCHRP 684 Internal Trip Capture Estimation Tool			
Project Name:	Heritage at Dalia Ranch	Organization:	Mizuta Traffic
Project Location:	Imperial, CA	Performed By:	MTC
Scenario Description:	n/a	Date:	17-Nov
Analysis Year:	n/a	Checked By:	MTC
Analysis Period:	PM Street Peak Hour	Date:	17-Nov

Table 1-P: Base Vehicle-Trip Generation Estimates (Single-Use Site Estimate)						
Land Use	Development Data (For Information Only)			Estimated Vehicle-Trips ³		
	ITE LUCs ¹	Quantity	Units	Total	Entering	Exiting
Office				115	33	82
Retail				134	65	69
Restaurant				157	82	75
Cinema/Entertainment				0		
Residential				264	168	96
Hotel				0		
All Other Land Uses ²				468	240	228
				1,138	588	550

Table 2-P: Mode Split and Vehicle Occupancy Estimates						
Land Use	Entering Trips			Exiting Trips		
	Veh. Occ. ⁴	% Transit	% Non-Motorized	Veh. Occ. ⁴	% Transit	% Non-Motorized
Office						
Retail						
Restaurant						
Cinema/Entertainment						
Residential						
Hotel						
All Other Land Uses ²						

Table 3-P: Average Land Use Interchange Distances (Feet Walking Distance)						
Origin (From)	Destination (To)					
	Office	Retail	Restaurant	Cinema/Entertainment	Residential	Hotel
Office						
Retail						
Restaurant						
Cinema/Entertainment						
Residential						
Hotel						

Table 4-P: Internal Person-Trip Origin-Destination Matrix*						
Origin (From)	Destination (To)					
	Office	Retail	Restaurant	Cinema/Entertainment	Residential	Hotel
Office		5	2	0	2	0
Retail	1		20	0	18	0
Restaurant	2	31		0	14	0
Cinema/Entertainment	0	0	0		0	0
Residential	4	7	11	0		0
Hotel	0	0	0	0	0	

Table 5-P: Computations Summary			
	Total	Entering	Exiting
All Person-Trips	1,138	588	550
Internal Capture Percentage	21%	20%	21%
External Vehicle-Trips ⁵	904	471	433
External Transit-Trips ⁶	0	0	0
External Non-Motorized Trips ⁶	0	0	0

Table 6-P: Internal Trip Capture Percentages by Land Use		
Land Use	Entering Trips	Exiting Trips
Office	21%	11%
Retail	66%	57%
Restaurant	40%	63%
Cinema/Entertainment	N/A	N/A
Residential	20%	23%
Hotel	N/A	N/A

¹Land Use Codes (LUCs) from *Trip Generation Manual*, published by the Institute of Transportation Engineers.

²Total estimate for all other land uses at mixed-use development site is not subject to internal trip capture computations in this estimator.

³Enter trips assuming no transit or non-motorized trips (as assumed in ITE *Trip Generation Manual*).

⁴Enter vehicle occupancy assumed in Table 1-P vehicle trips. If vehicle occupancy changes for proposed mixed-use project, manual adjustments must be made.

⁵Vehicle-trips computed using the mode split and vehicle occupancy values provided in Table 2-P.

⁶Person-Trips

*Indicates computation that has been rounded to the nearest whole number.

Estimation Tool Developed by the Texas A&M Transportation Institute - Version 2013.1

Project Name:	Heritage at Dalia Ranch
Analysis Period:	PM Street Peak Hour

Land Use	Table 7-P (D): Entering Trips			Table 7-P (O): Exiting Trips		
	Veh. Occ.	Vehicle-Trips	Person-Trips*	Veh. Occ.	Vehicle-Trips	Person-Trips*
Office	1.00	33	33	1.00	82	82
Retail	1.00	65	65	1.00	69	69
Restaurant	1.00	82	82	1.00	75	75
Cinema/Entertainment	1.00	0	0	1.00	0	0
Residential	1.00	168	168	1.00	96	96
Hotel	1.00	0	0	1.00	0	0

Origin (From)	Destination (To)					
	Office	Retail	Restaurant	Cinema/Entertainment	Residential	Hotel
Office		16	3	0	2	0
Retail	1		20	3	18	3
Restaurant	2	31		6	14	5
Cinema/Entertainment	0	0	0		0	0
Residential	4	40	20	0		3
Hotel	0	0	0	0	0	

Origin (From)	Destination (To)					
	Office	Retail	Restaurant	Cinema/Entertainment	Residential	Hotel
Office		5	2	0	7	0
Retail	10		24	0	77	0
Restaurant	10	33		0	27	0
Cinema/Entertainment	2	3	2		7	0
Residential	19	7	11	0		0
Hotel	0	1	4	0	0	

Destination Land Use	Person-Trip Estimates			External Trips by Mode*		
	Internal	External	Total	Vehicles ¹	Transit ²	Non-Motorized ²
Office	7	26	33	26	0	0
Retail	43	22	65	22	0	0
Restaurant	33	49	82	49	0	0
Cinema/Entertainment	0	0	0	0	0	0
Residential	34	134	168	134	0	0
Hotel	0	0	0	0	0	0
All Other Land Uses ³	0	240	240	240	0	0

Origin Land Use	Person-Trip Estimates			External Trips by Mode*		
	Internal	External	Total	Vehicles ¹	Transit ²	Non-Motorized ²
Office	9	73	82	73	0	0
Retail	39	30	69	30	0	0
Restaurant	47	28	75	28	0	0
Cinema/Entertainment	0	0	0	0	0	0
Residential	22	74	96	74	0	0
Hotel	0	0	0	0	0	0
All Other Land Uses ³	0	228	228	228	0	0

¹Vehicle-trips computed using the mode split and vehicle occupancy values provided in Table 2-P

²Person-Trips

³Total estimate for all other land uses at mixed-use development site is not subject to internal trip capture computations in this estimator

*Indicates computation that has been rounded to the nearest whole number.

Appendix E

SCAG Profile of Imperial County Report Excerpts

Profile of Imperial County

Southern California Association of Governments (SCAG) Regional Council includes 69 districts which represent 191 cities and 6 counties in the SCAG region



LOCAL PROFILES REPORT 2019

This profile report was prepared by the Southern California Association of Governments and shared with Imperial County. SCAG provides local governments with a variety of benefits and services including, for example, data and information, GIS training, planning and technical assistance, and sustainability planning grants.

II. POPULATION

Population Growth

Population: 2000 - 2018

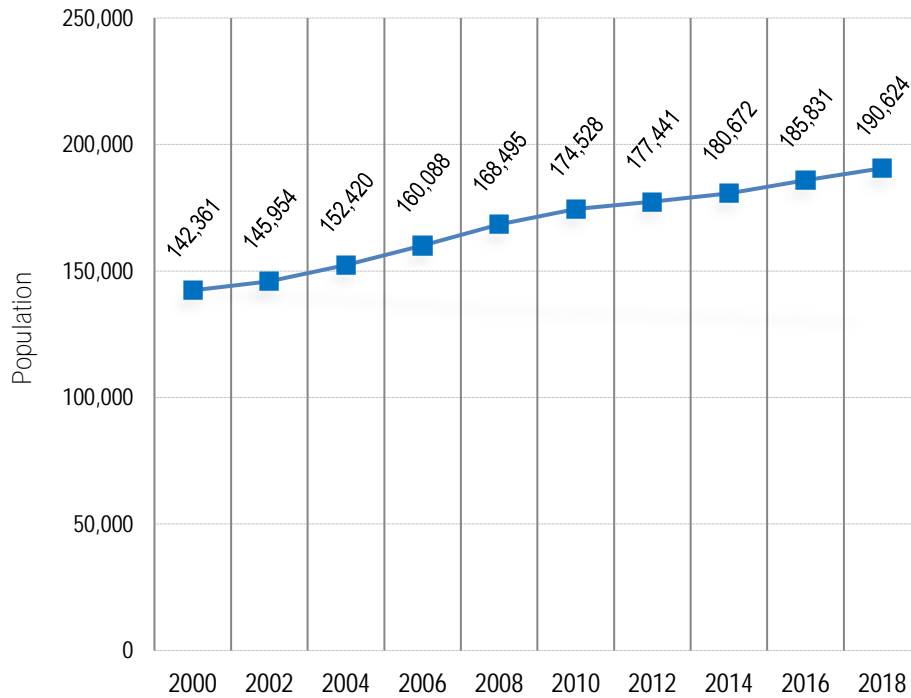

Source: California Department of Finance, E-5, 2000-2018

- Between 2000 and 2018, the total population of Imperial County increased by 48,263 to 190,624.
- During this 18-year period, the county’s population growth rate of 33.9 percent was higher than the SCAG Region rate of 15.9 percent.
- 1.0 percent of the total population of SCAG Region is in Imperial County.
- Population values for 2000 and 2010 are from the U.S. Decennial Census.
- Values for other years are estimates by the California Department of Finance.